

# **P-Town Auto & Offroad, LLC**

688 Harshaw Ave.  
Patagonia, AZ 85624  
(520) 394-0181 T

YMMS: 2018 Chrysler 300 S

Engine: 3.6L Eng

VIN:

Jun 7, 2024

License:

Odometer:

**ENGINE PERFORMANCE > 5.7L**

Fig 1: 5.7L, Engine Performance Circuit (1 of 5)

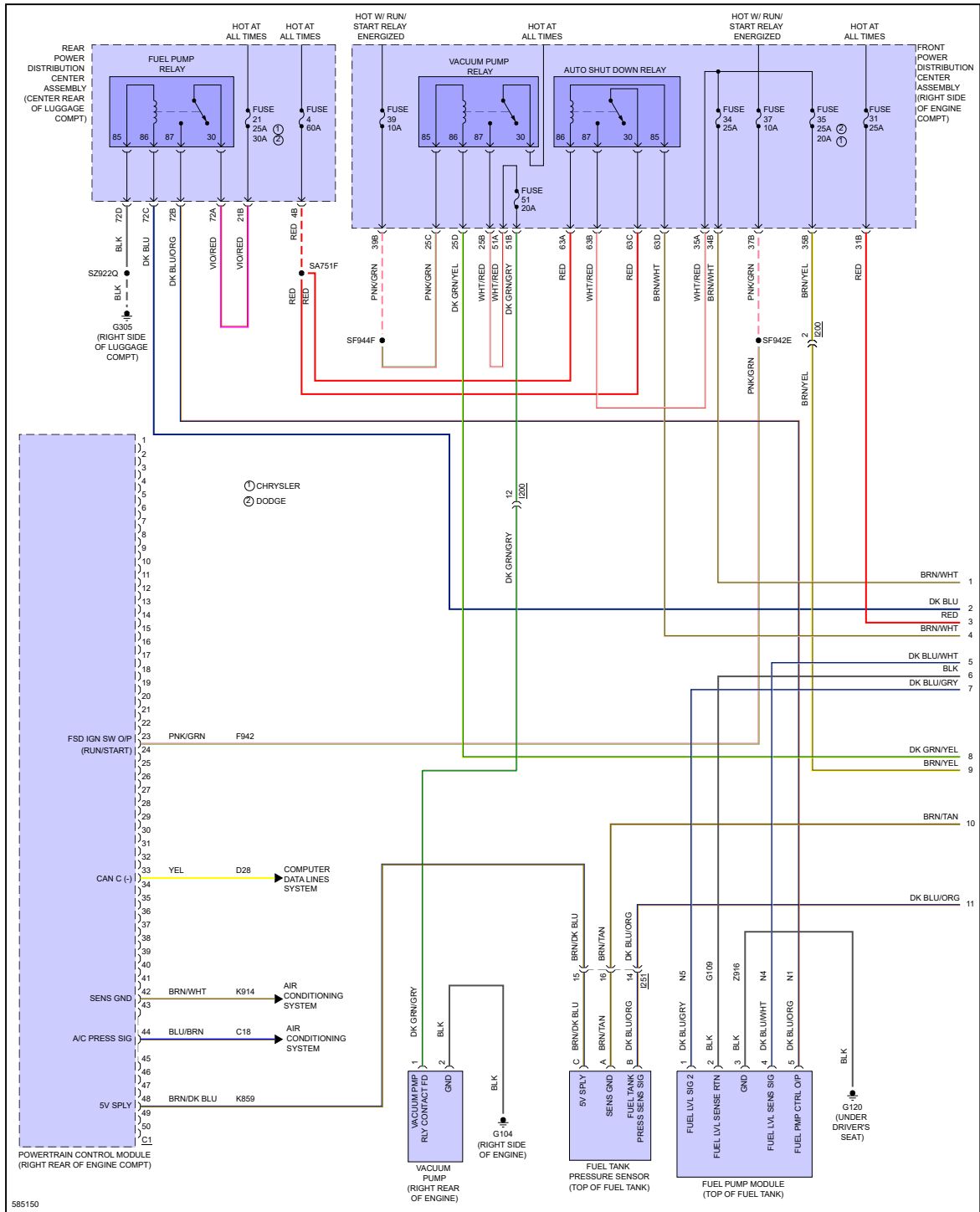

Fig 2: 5.7L, Engine Performance Circuit (2 of 5)

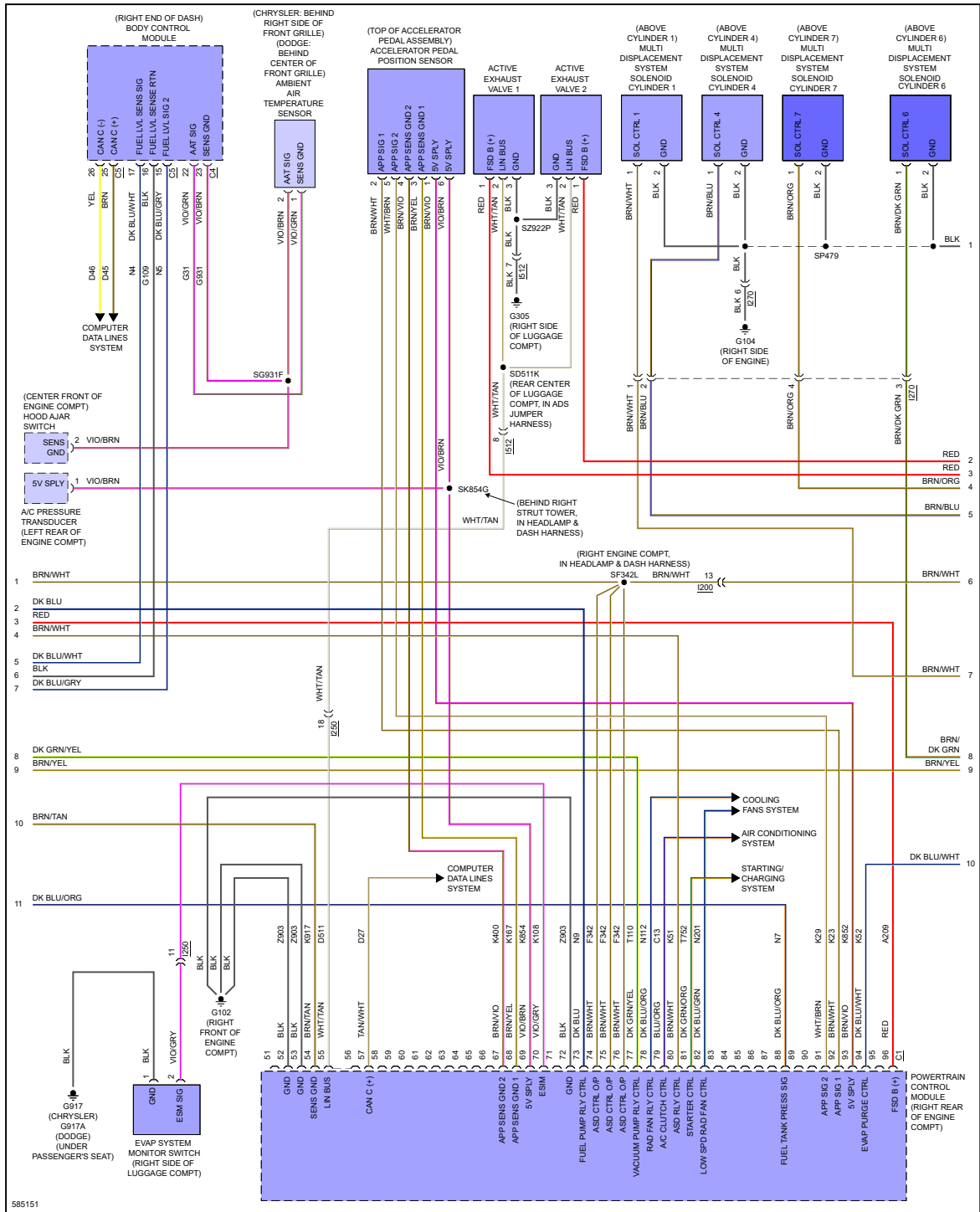

Fig 3: 5.7L, Engine Performance Circuit (3 of 5)

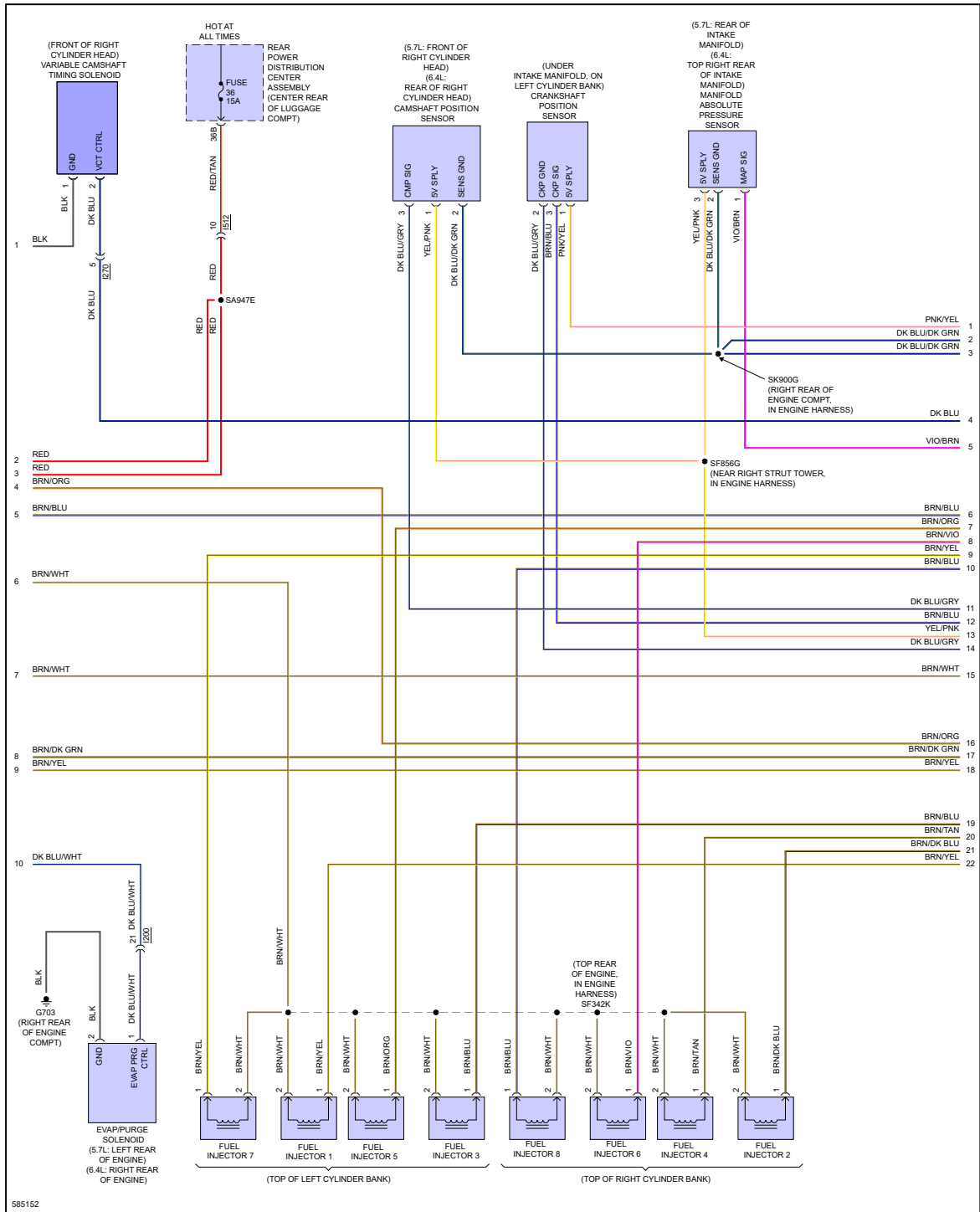
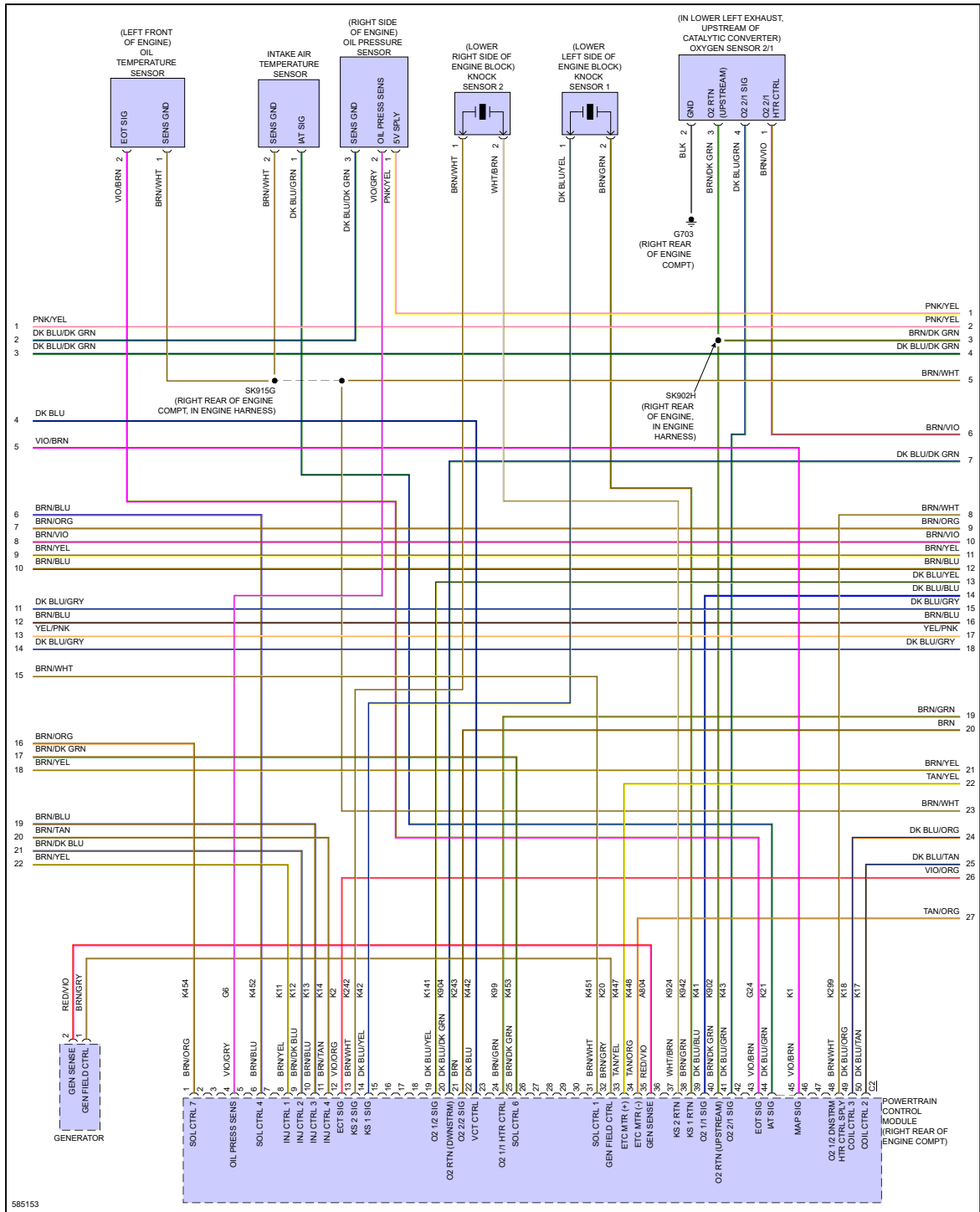

Fig 4: 5.7L, Engine Performance Circuit (4 of 5)





*"If your car is beat down, bring it to P-Town!"*