

# P-Town Auto & Offroad, LLC

688 Harshaw Ave.  
Patagonia, AZ 85624  
(520) 394-0181 T

YMMS: 2014 Kia Rio LX  
Engine: 1.6L Eng  
VIN:

Aug 21, 2024

License:  
Odometer:

## INSTRUMENT CLUSTER

Fig 1: Clock Circuit

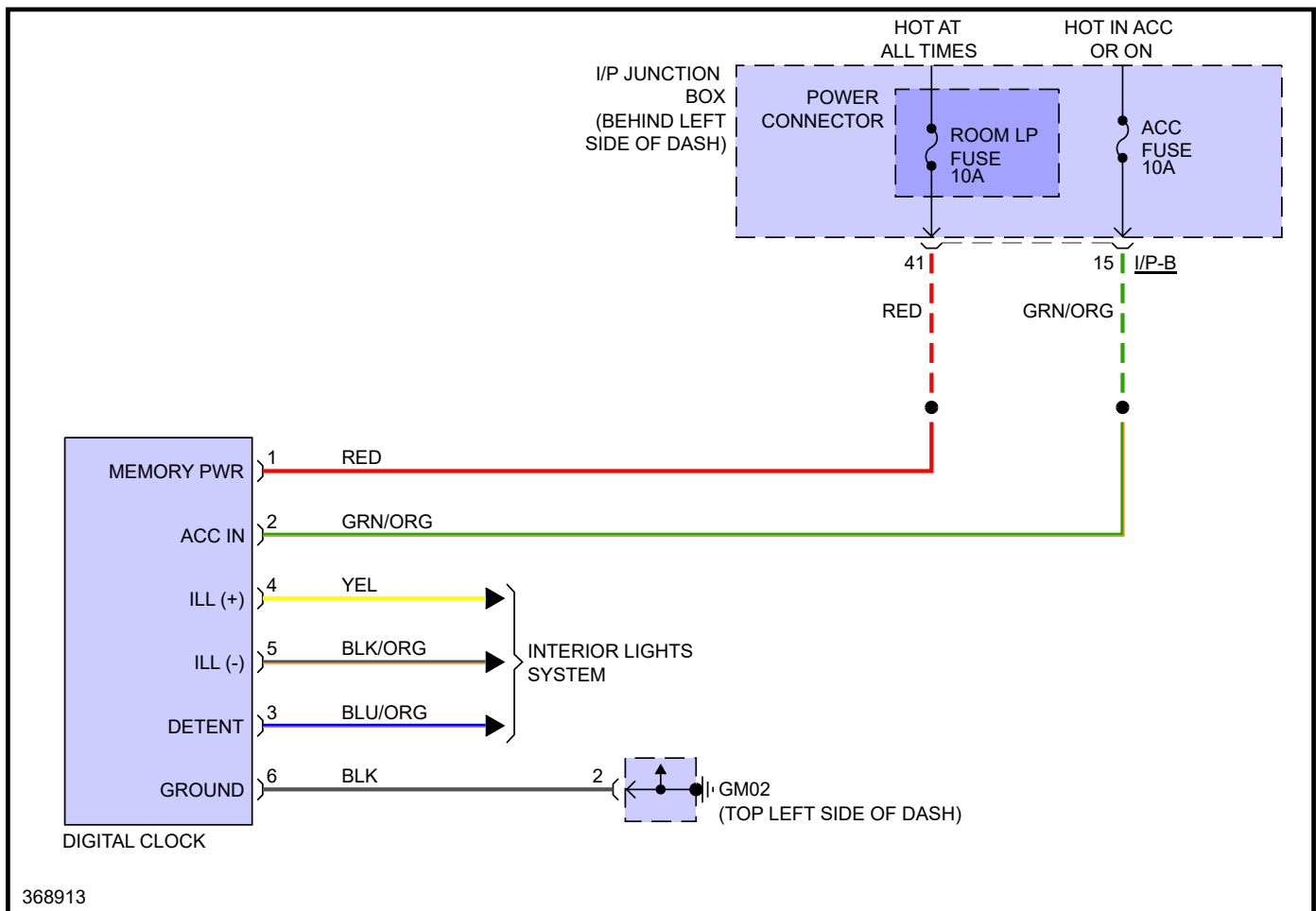

Fig 2: Instrument Cluster Circuit, W/ Super Vision (1 of 2)

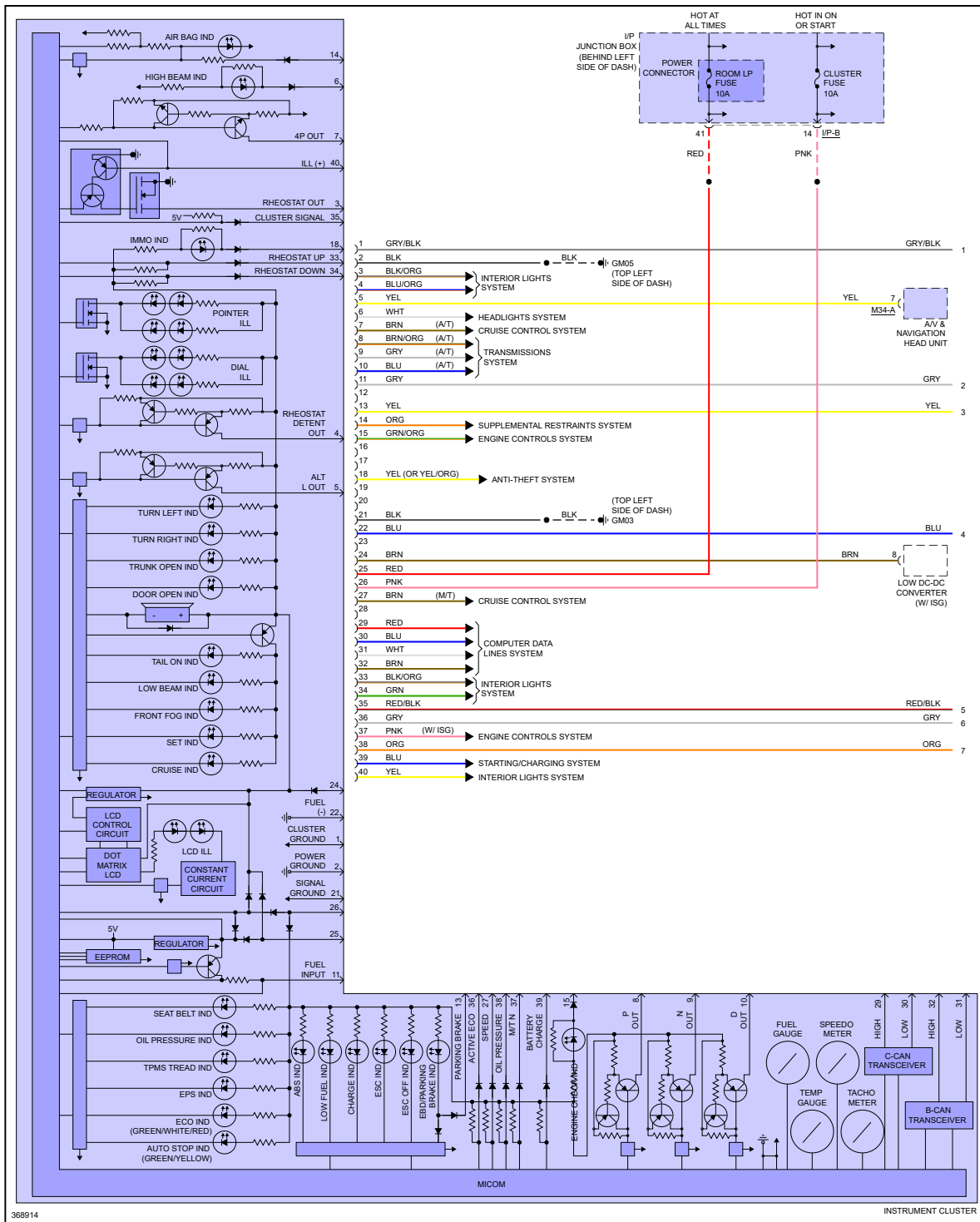
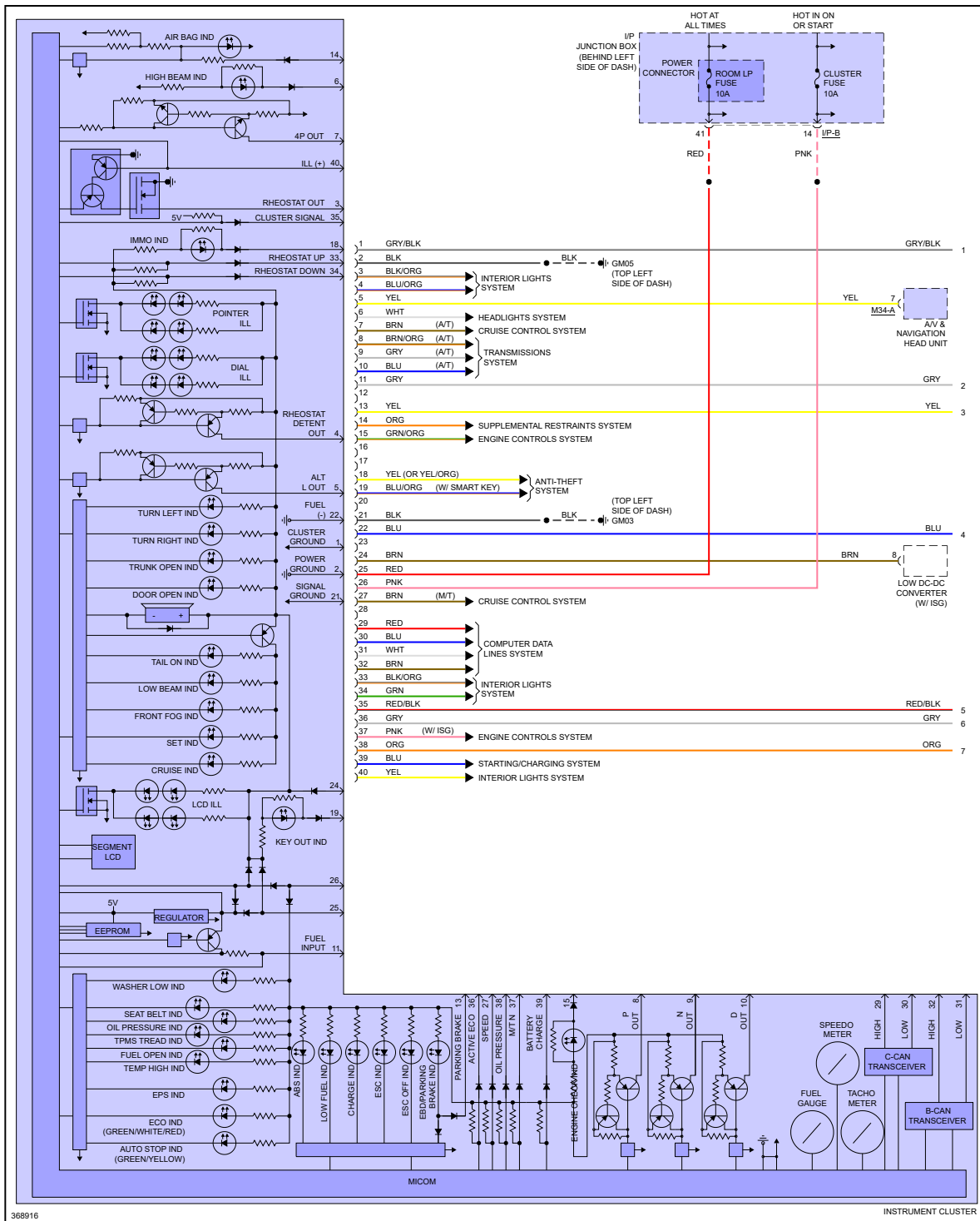



Fig 4: Instrument Cluster Circuit, W/O Super Vision (1 of 2)



368916

INSTRUMENT CLUSTER

Fig 5: Instrument Cluster Circuit, W/O Super Vision (2 of 2)

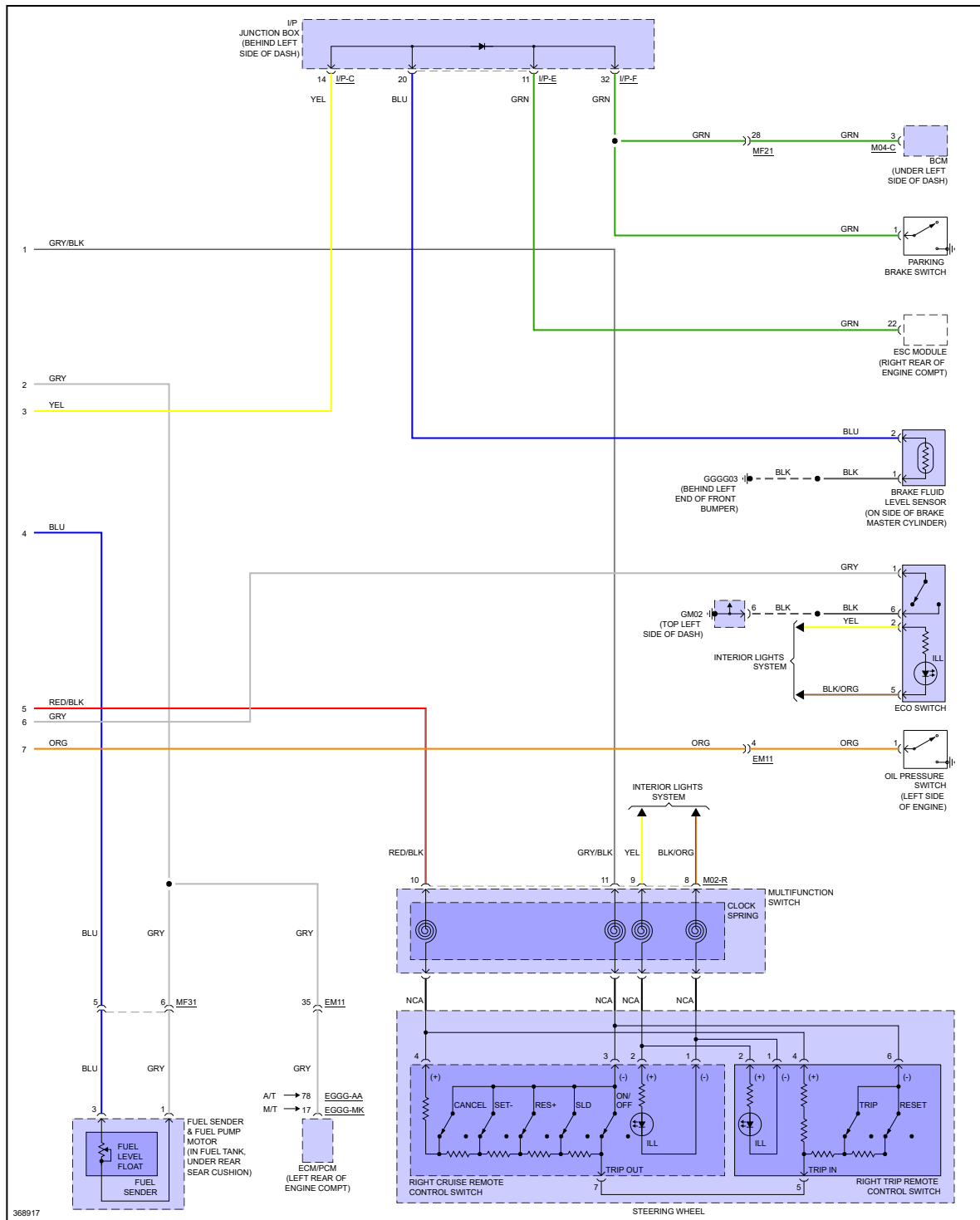

368917

*"If your car is beat down, bring it to P-Town!"*