

# P-Town Auto & Offroad, LLC

688 Harshav Ave.  
Patagonia, AZ 85624  
(520) 394-0181 T

YMMS: 2011 Nissan Xterra S  
Engine: 4.0L Eng  
VIN:

Aug 21, 2024

License:  
Odometer:

## INSTRUMENT CLUSTER

Fig 1: Instrument Cluster Circuit

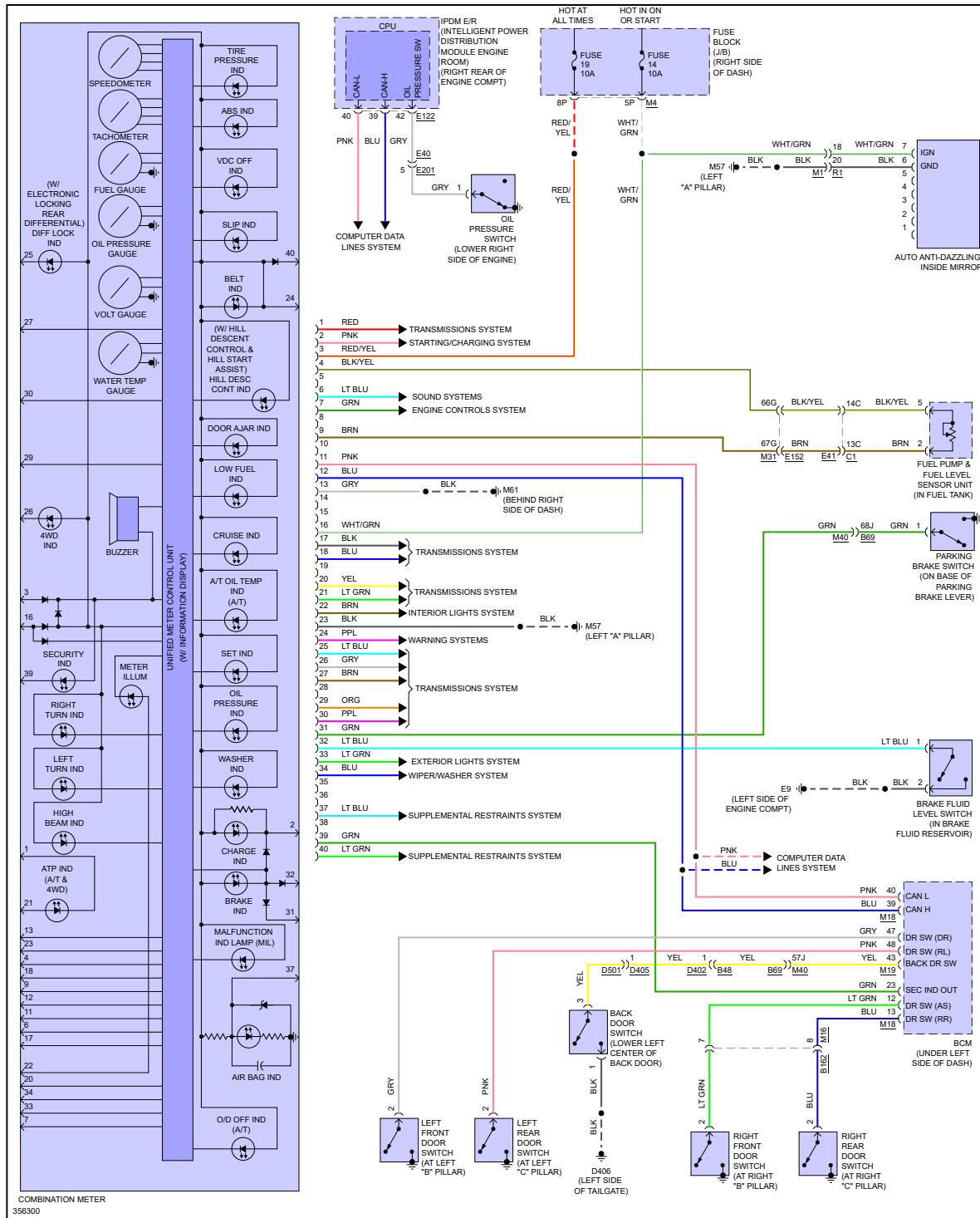

*"If your car is beat down, bring it to P-Town!"*