

# P-Town Auto & Offroad, LLC

688 Harshaw Ave.  
Patagonia, AZ 85624  
(520) 394-0181 T

YMMS: 2017 Infiniti Q50 Red Sport 400

Engine: 3.0L Eng

VIN:

Jul 1, 2024

License:

Odometer:

**ENGINE PERFORMANCE > 3.0L TURBO**

Fig 1: 3.0L Turbo, Engine Performance Circuit (1 of 8)

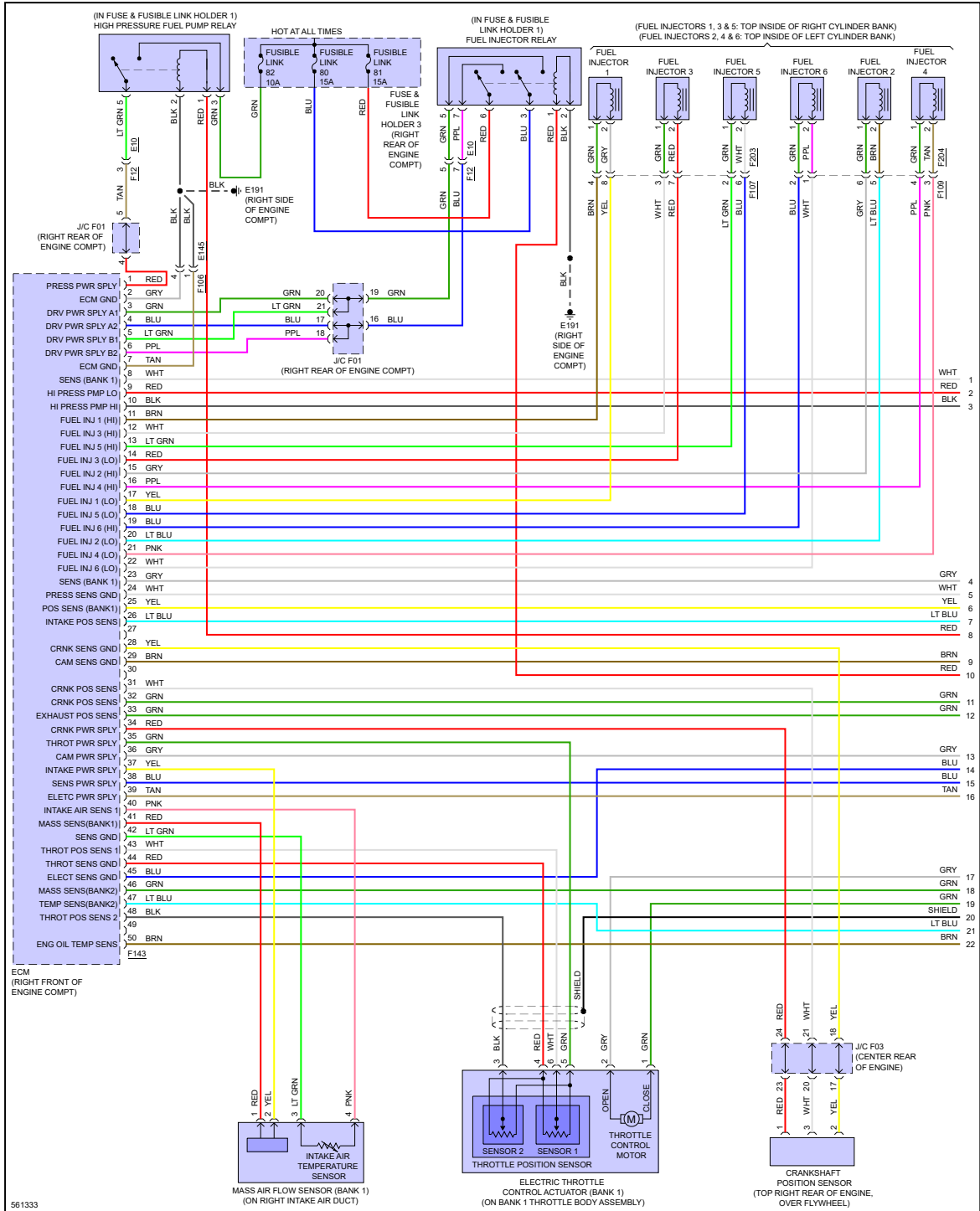



Fig 3: 3.0L Turbo, Engine Performance Circuit (3 of 8)

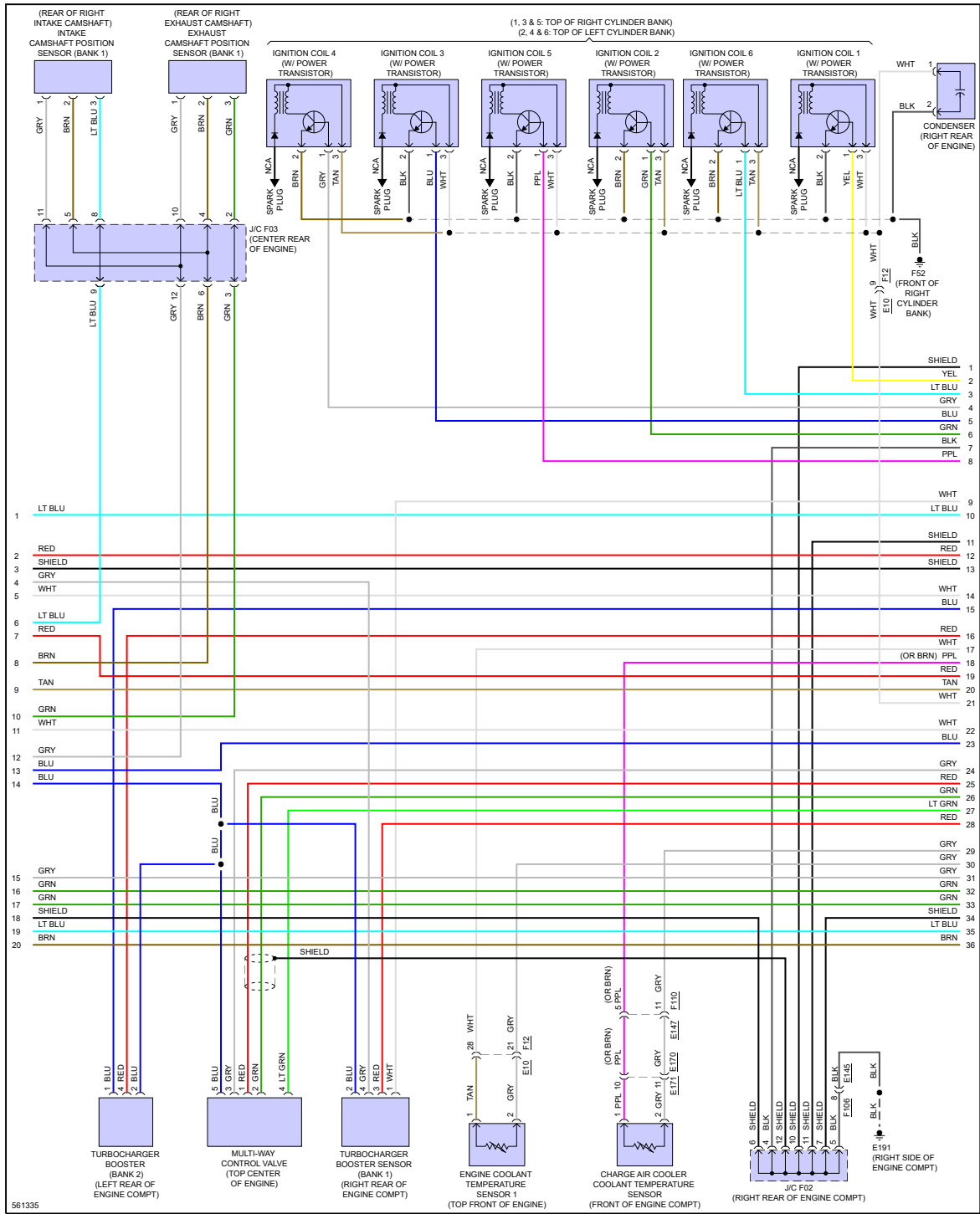

Fig 4: 3.0L Turbo, Engine Performance Circuit (4 of 8)

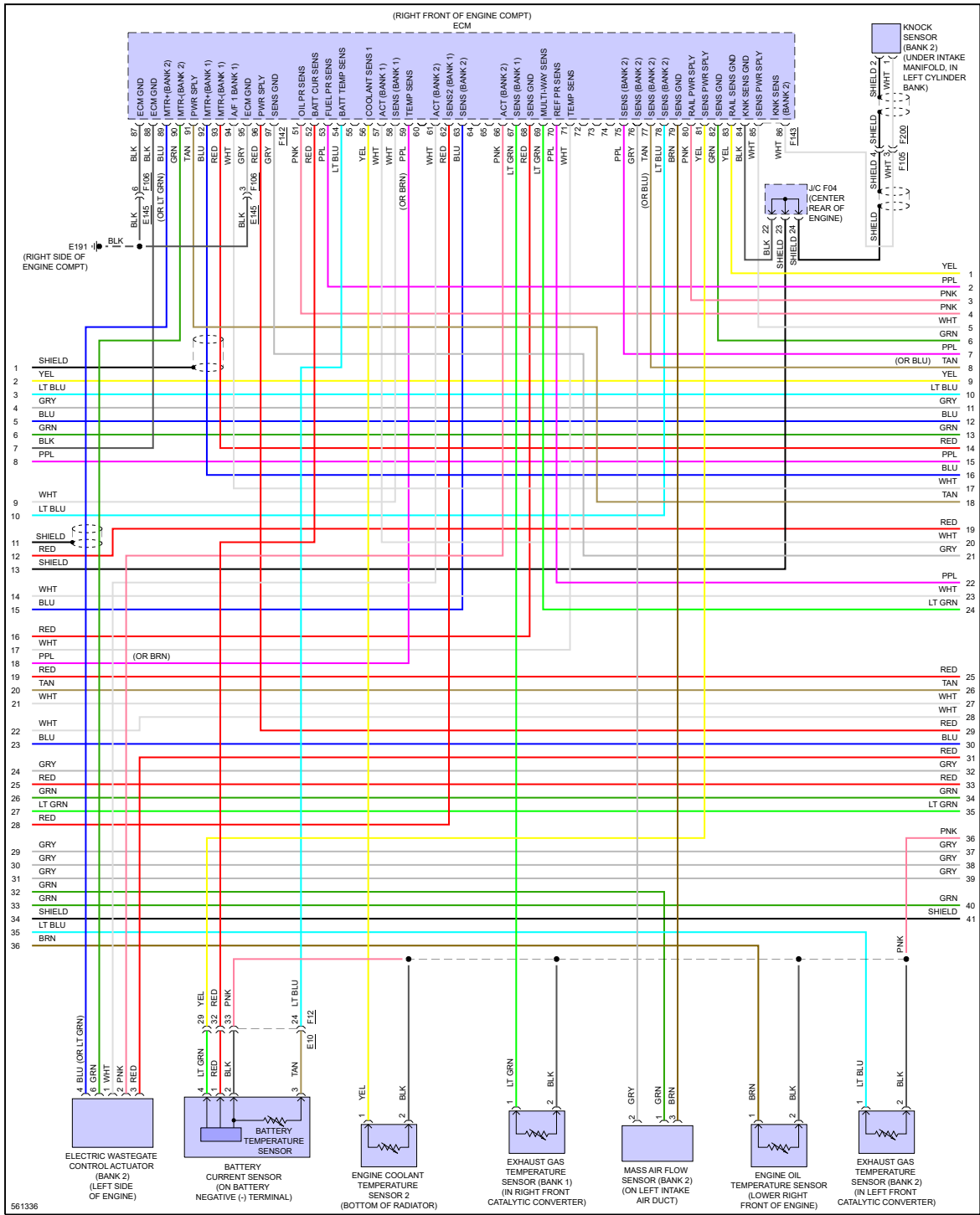

Fig 5: 3.0L Turbo, Engine Performance Circuit (5 of 8)

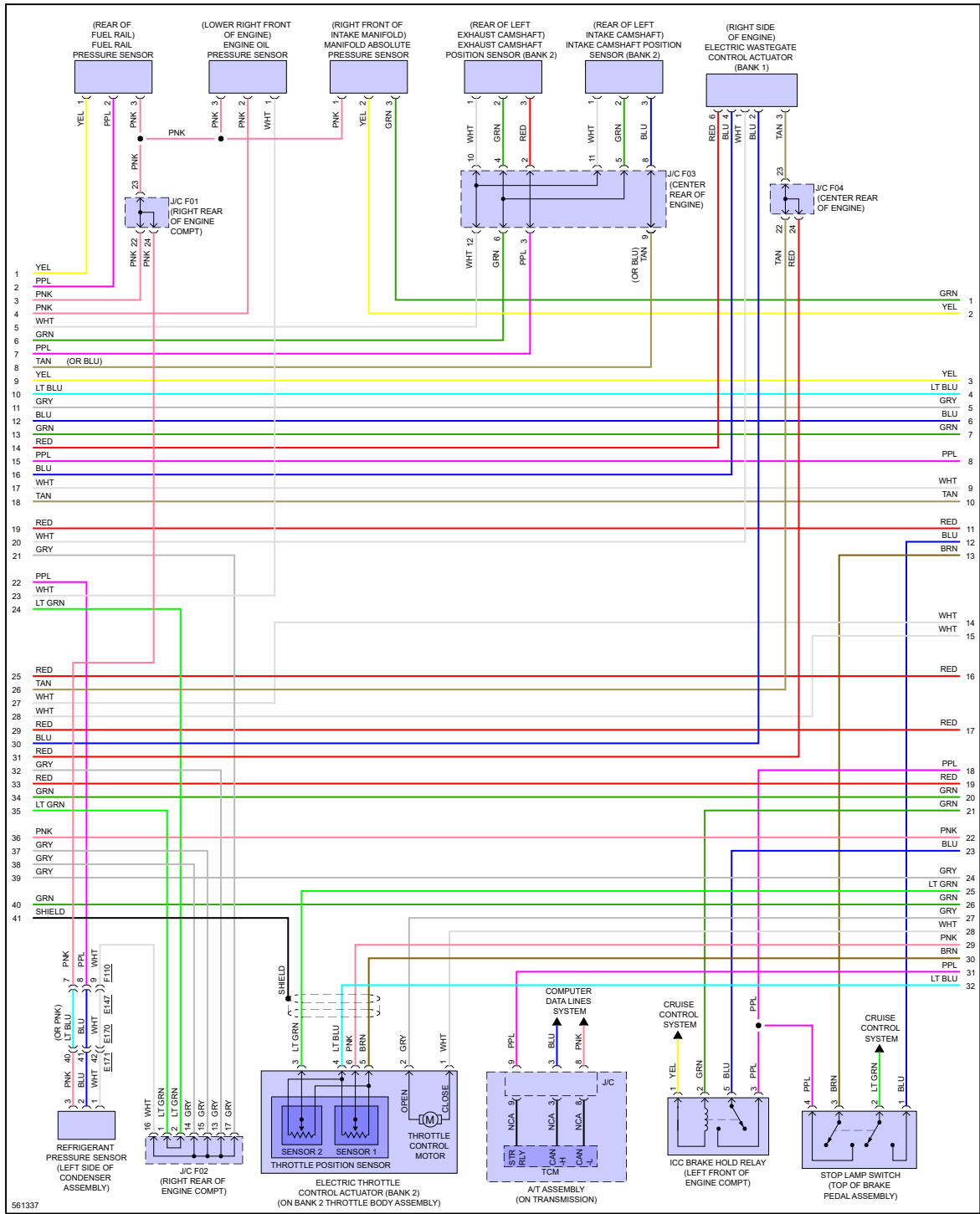



Fig 7: 3.0L Turbo, Engine Performance Circuit (7 of 8)

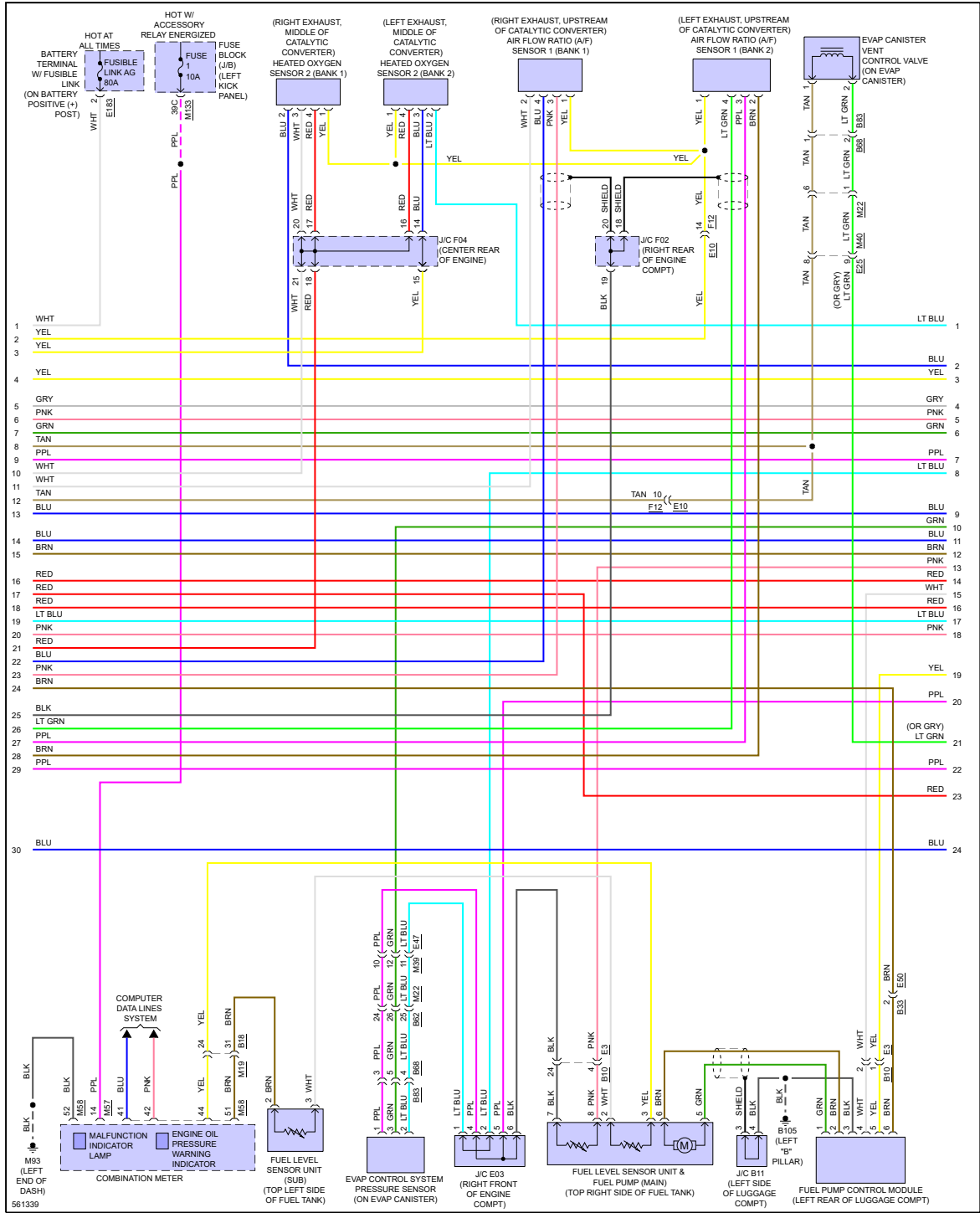
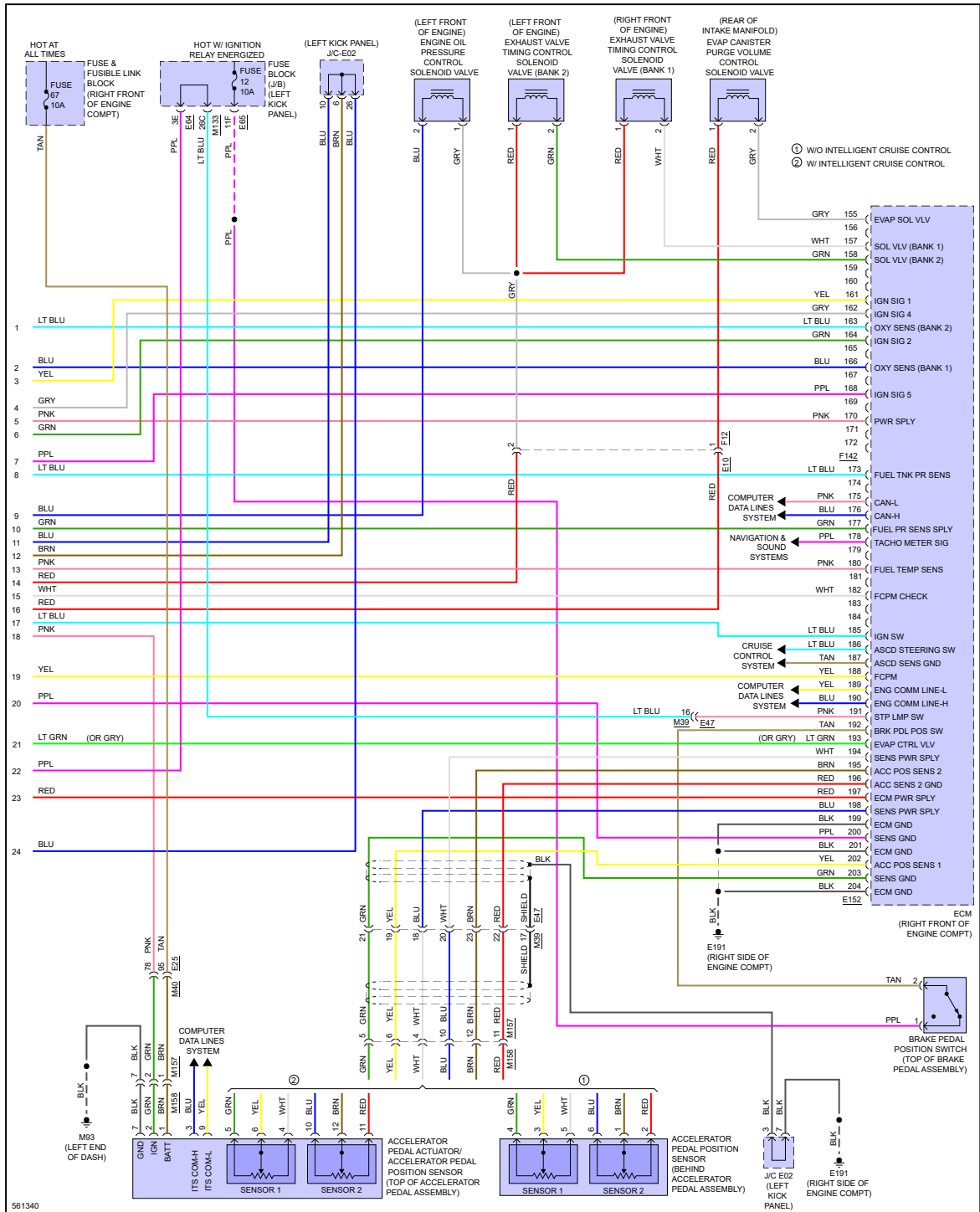



Fig 8: 3.0L Turbo, Engine Performance Circuit (8 of 8)



*"If your car is beat down, bring it to P-Town!"*