

PRODEMAND

YMMS: 2014 Mitsubishi Lancer GT
Engine: 2.4L Eng
VIN:

May 26, 2023
License:
Odometer:

ENGINE PERFORMANCE > 2.0L TURBO

Fig 1: 2.0L Turbo, Engine Performance Circuit, Evolution (1 of 4)

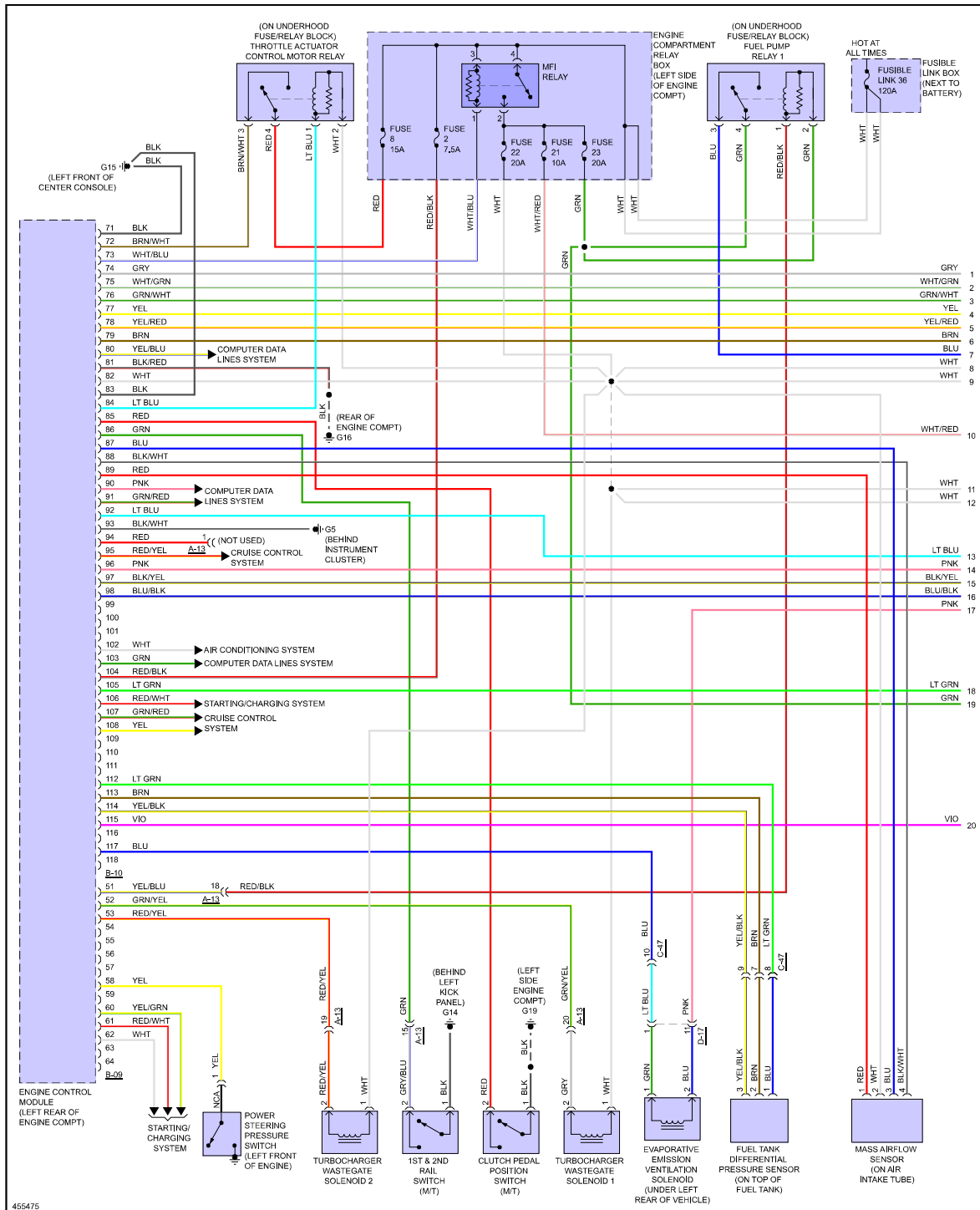

Fig 2: 2.0L Turbo, Engine Performance Circuit, Evolution (2 of 4)

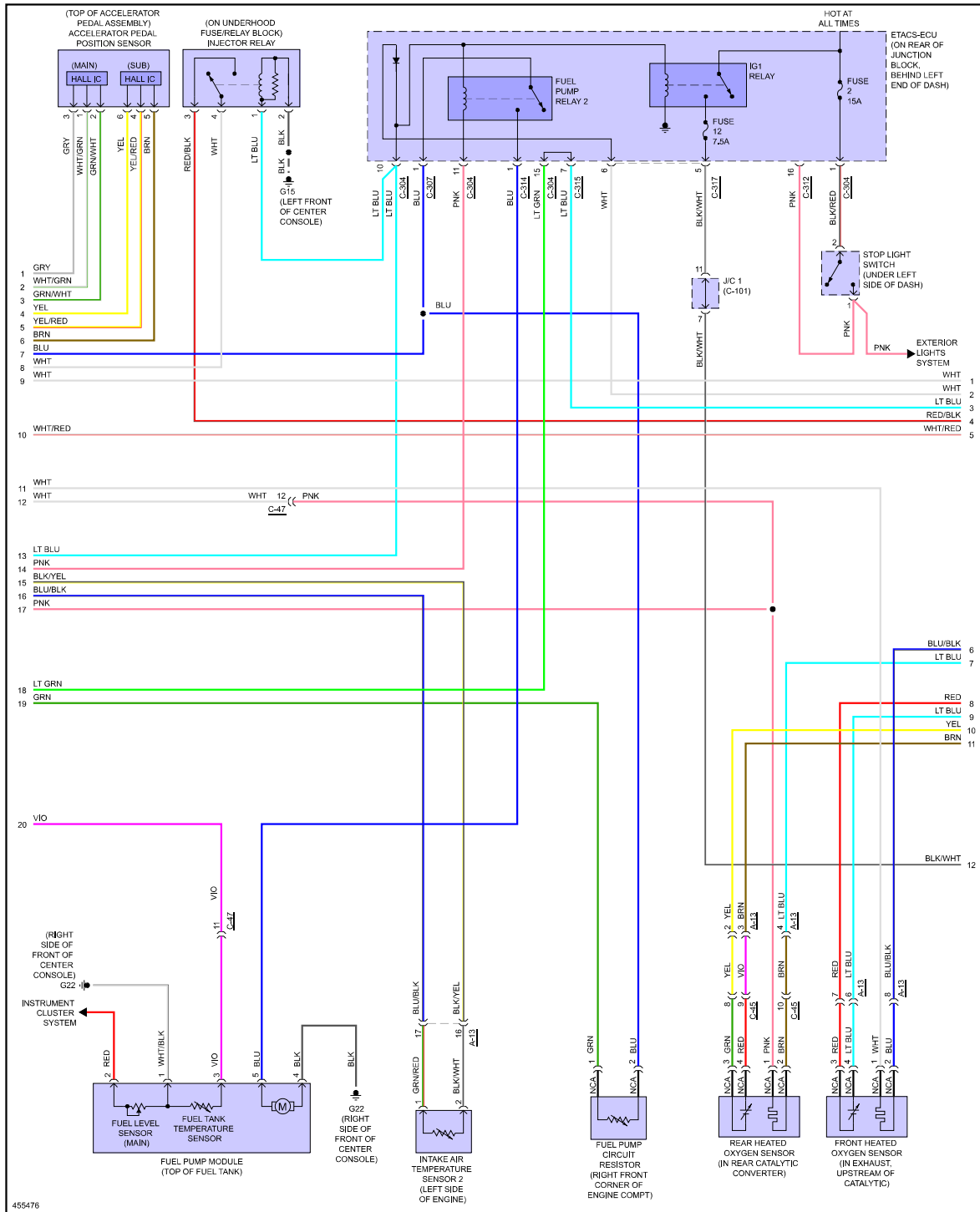

Fig 3: 2.0L Turbo, Engine Performance Circuit, Evolution (3 of 4)

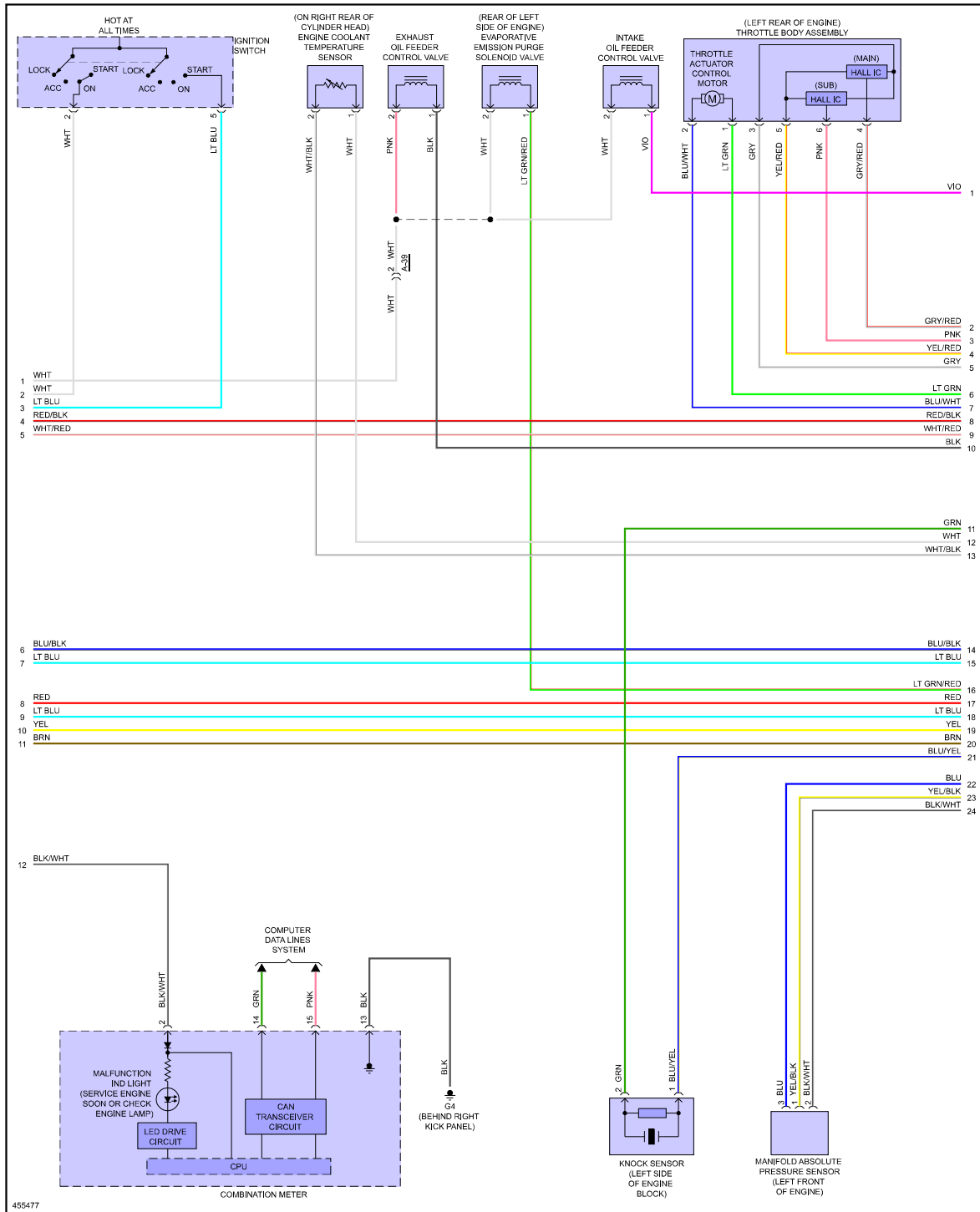

Fig 4: 2.0L Turbo, Engine Performance Circuit, Evolution (4 of 4)

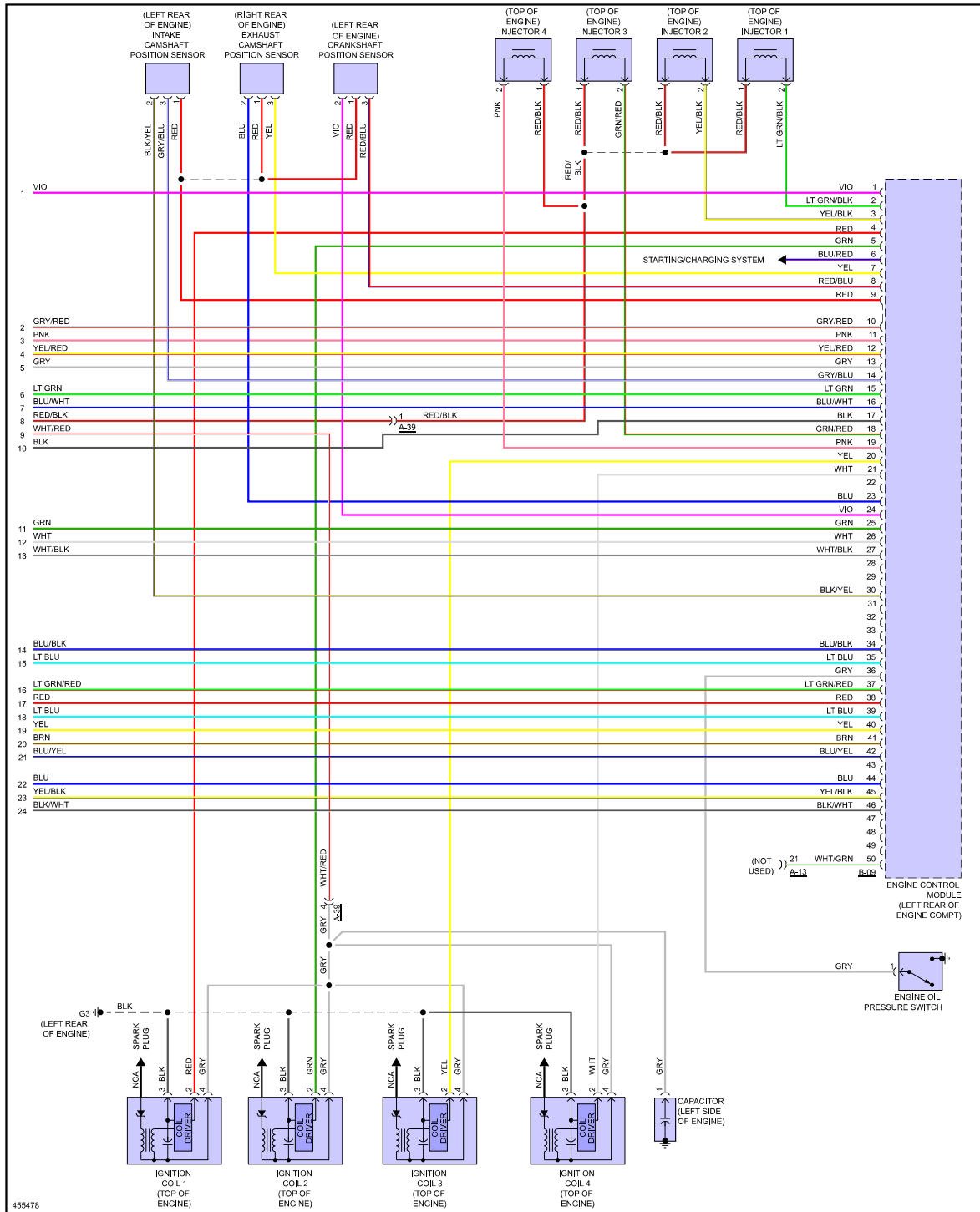

Fig 5: 2.0L Turbo, Engine Performance Circuit, Except Evolution (1 of 4)

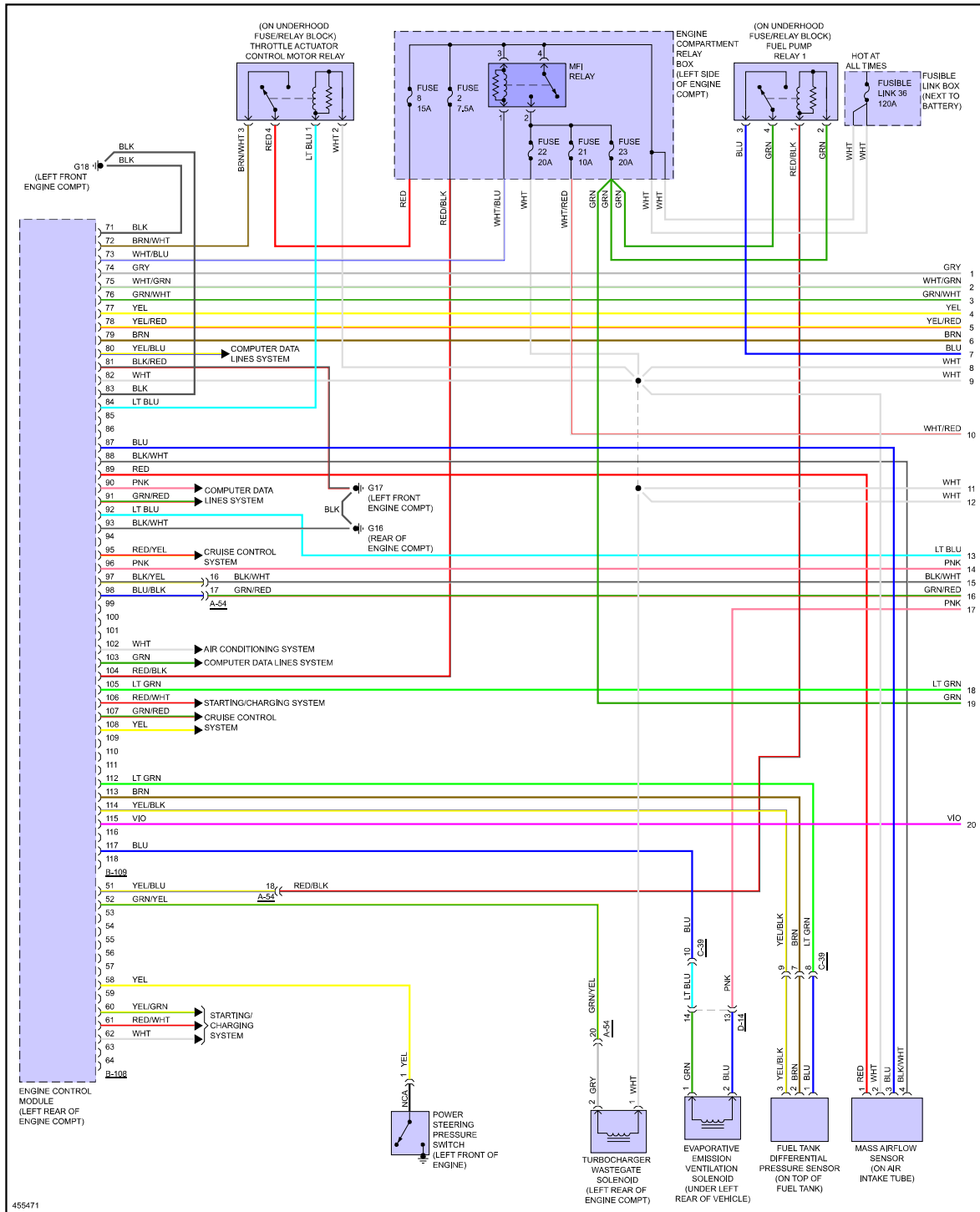

Fig 6: 2.0L Turbo, Engine Performance Circuit, Except Evolution (2 of 4)

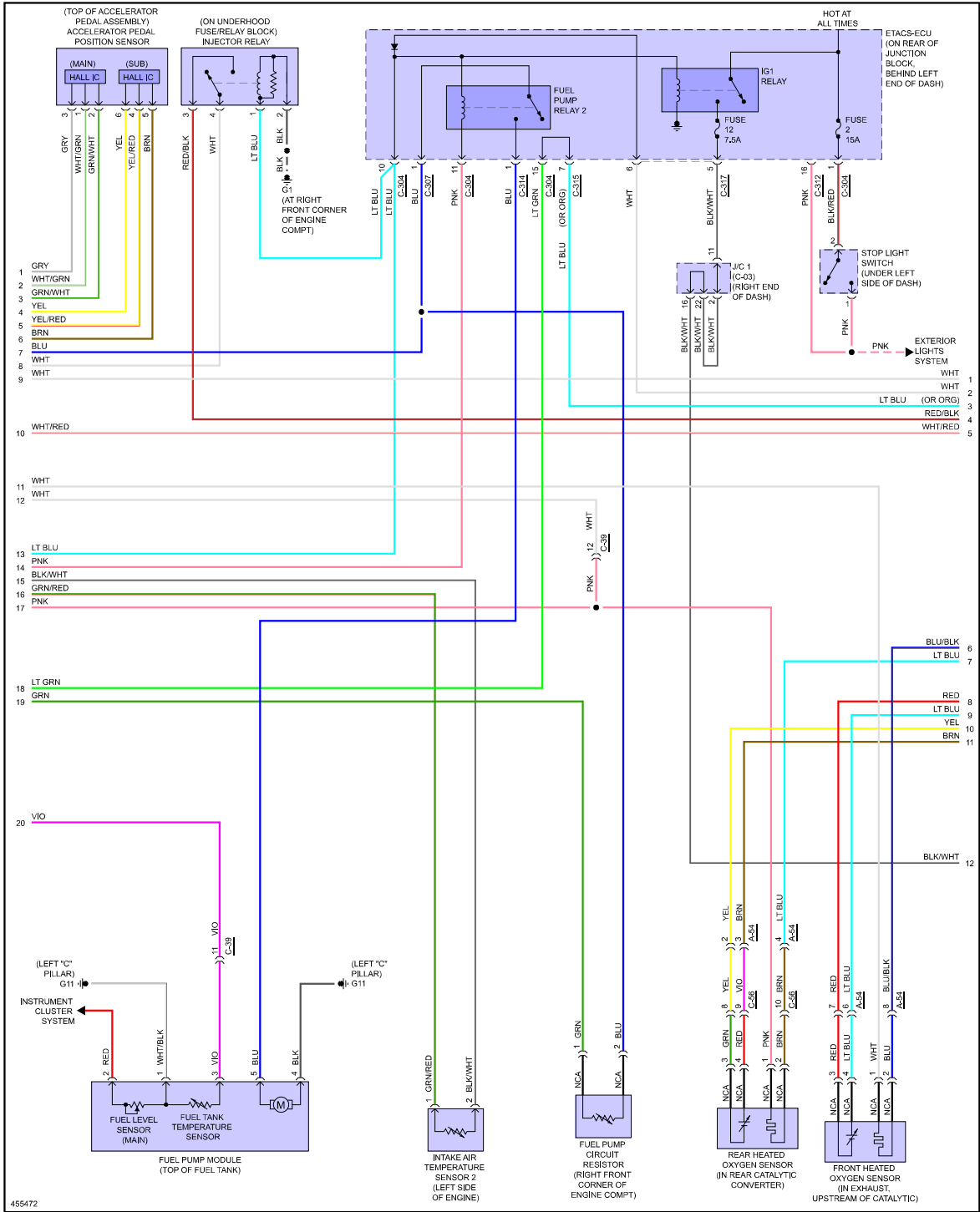
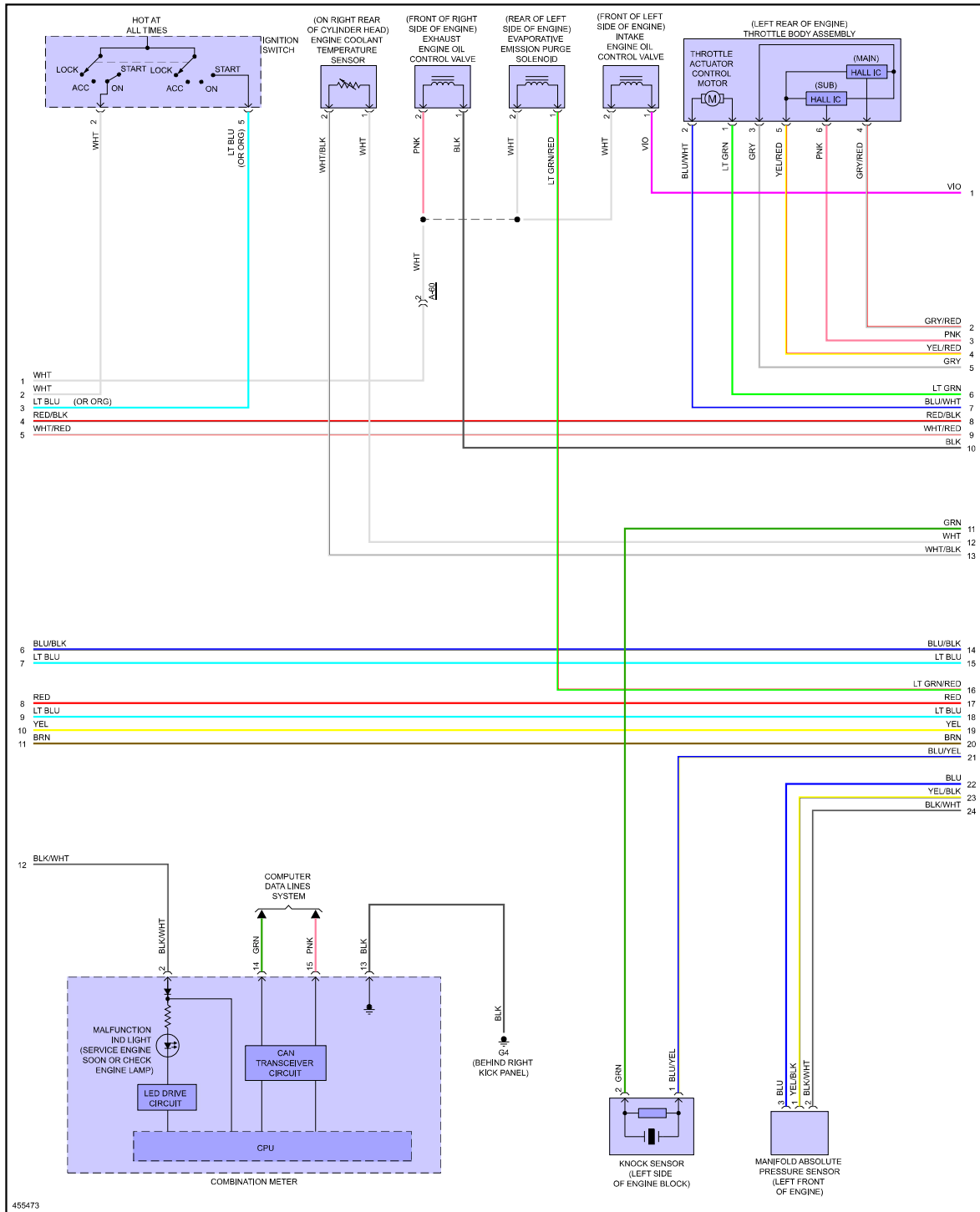

Fig 7: 2.0L Turbo, Engine Performance Circuit, Except Evolution (3 of 4)



455473

Fig 8: 2.0L Turbo, Engine Performance Circuit, Except Evolution (4 of 4)

