

P-Town Auto & Offroad, LLC

688 Harshaw Ave.
Patagonia, AZ 85624
(520) 394-0181 T

YMMS: 2015 Infiniti Q70 3.7

Engine: 3.7L Eng

VIN:

Jul 2, 2024

License:

Odometer:

ENGINE PERFORMANCE > 3.7L

Fig 1: 3.7L, Engine Performance Circuit (1 of 6)

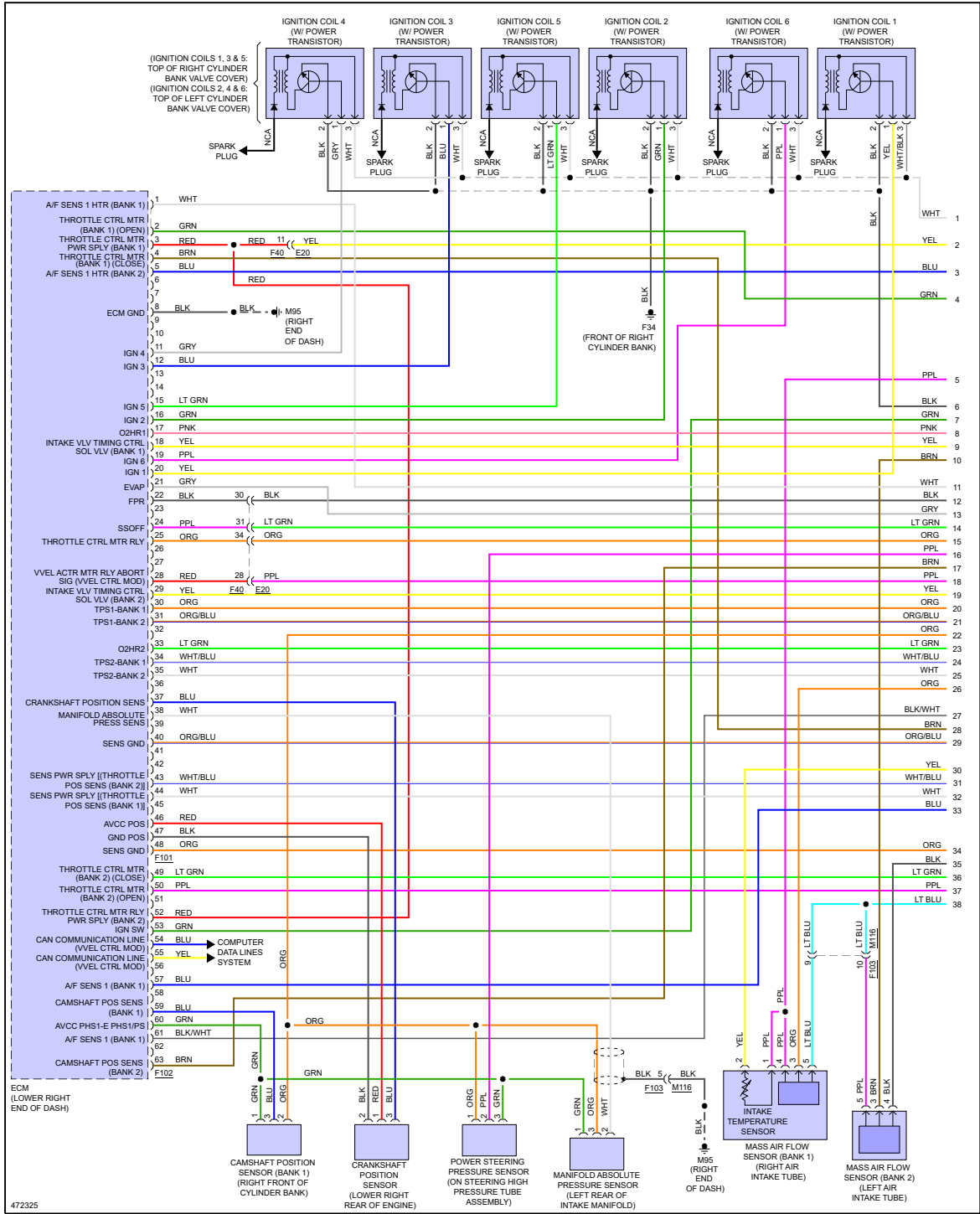

Fig 2: 3.7L, Engine Performance Circuit (2 of 6)

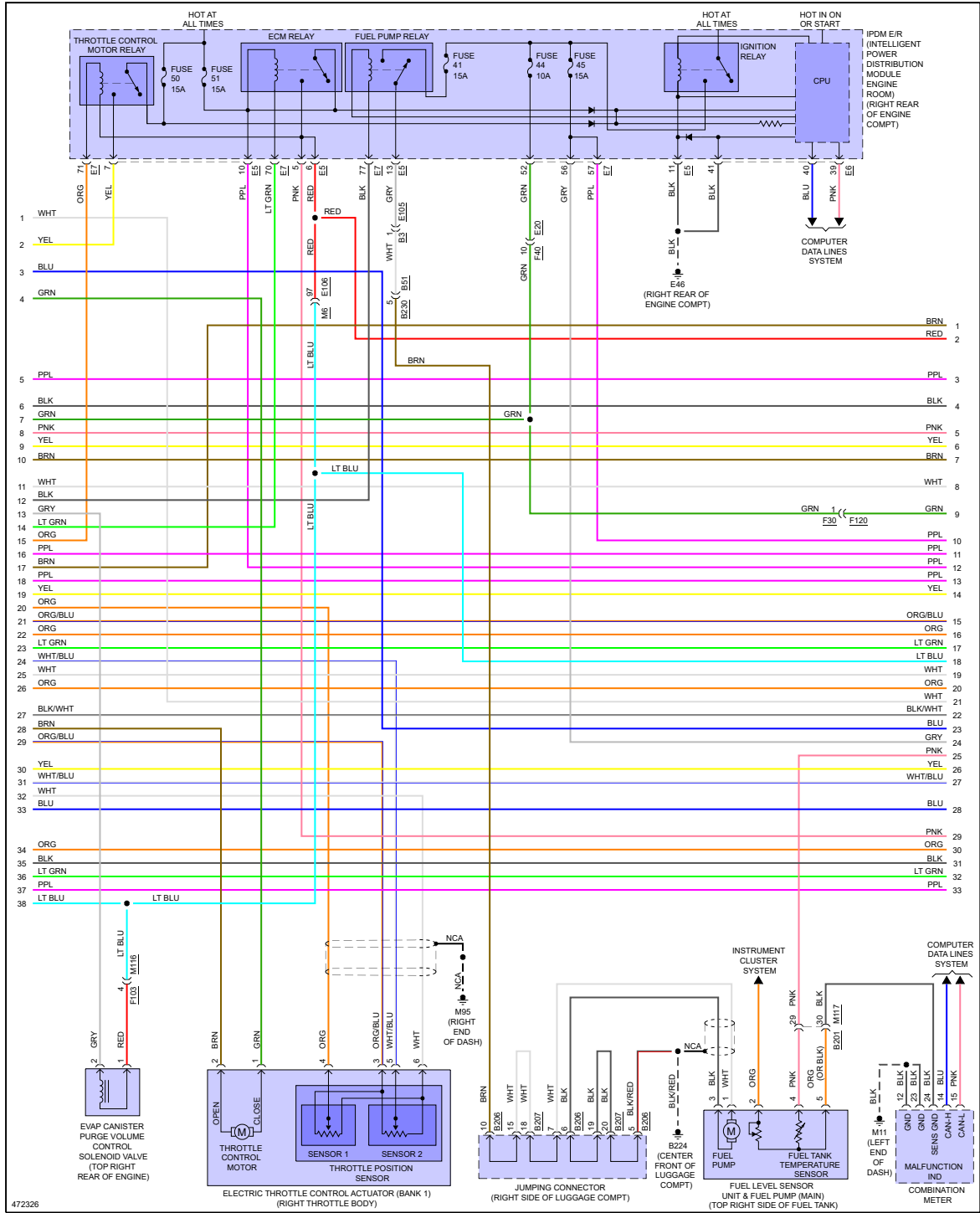

Fig 3: 3.7L, Engine Performance Circuit (3 of 6)

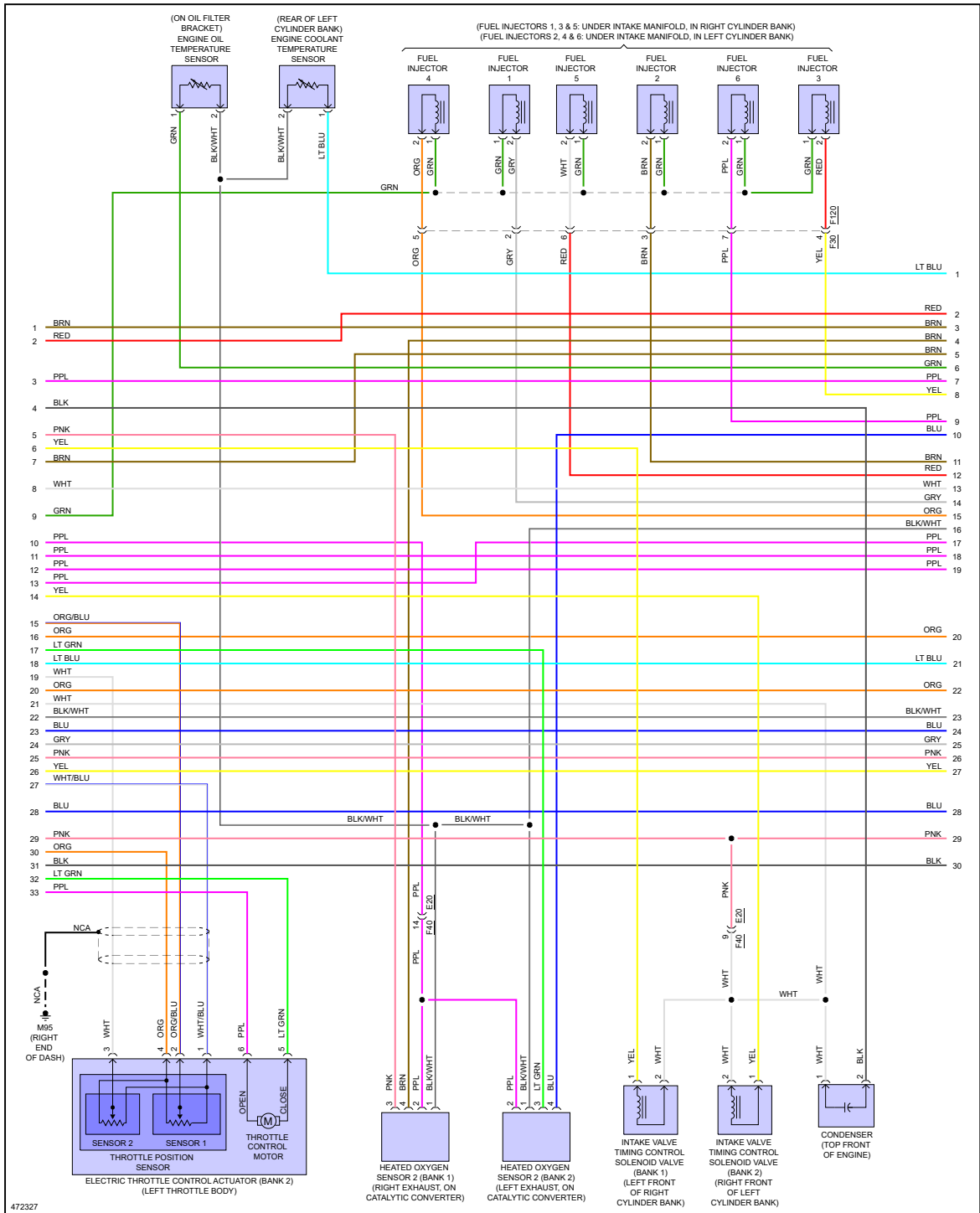

Fig 4: 3.7L, Engine Performance Circuit (4 of 6)

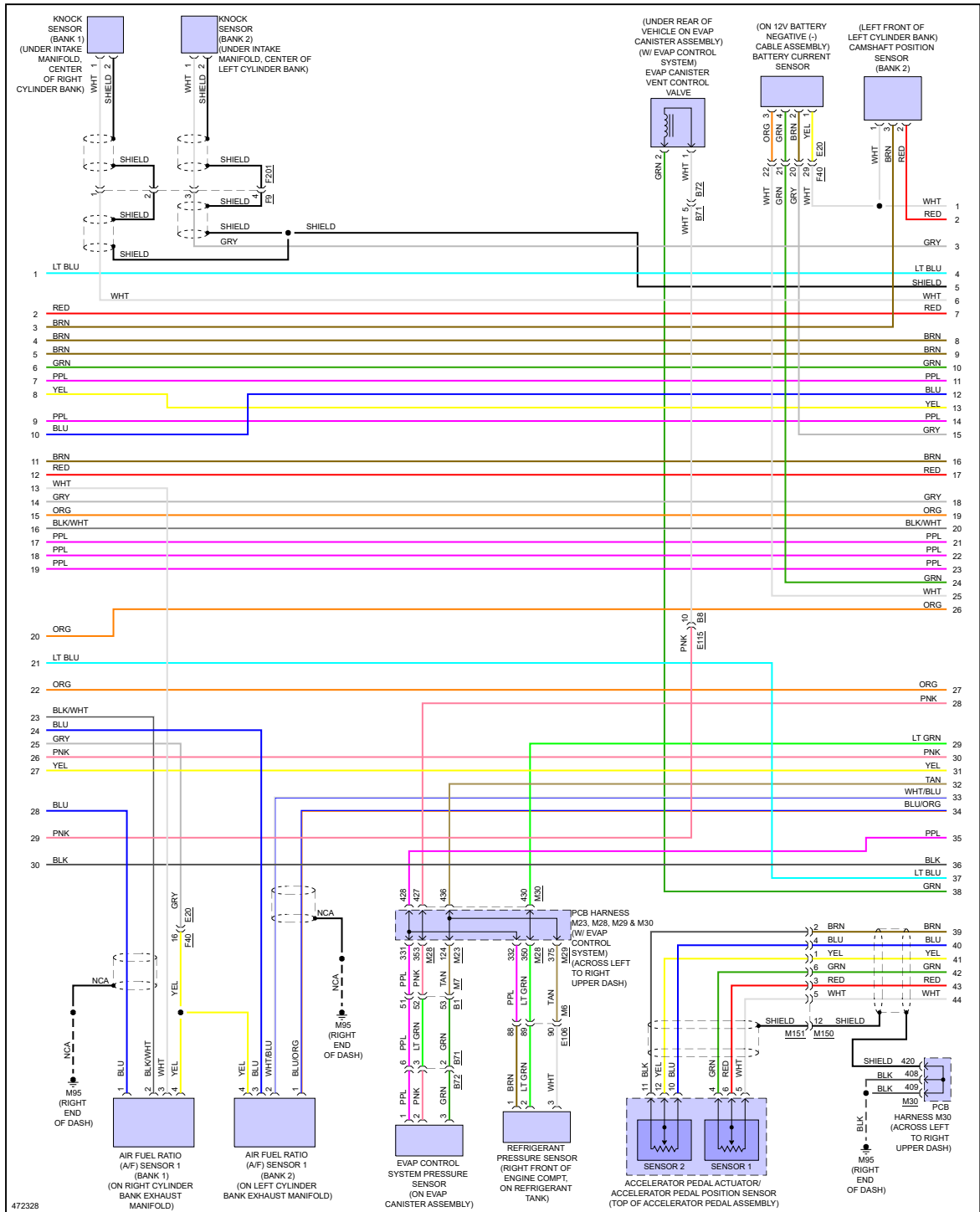

Fig 5: 3.7L, Engine Performance Circuit (5 of 6)

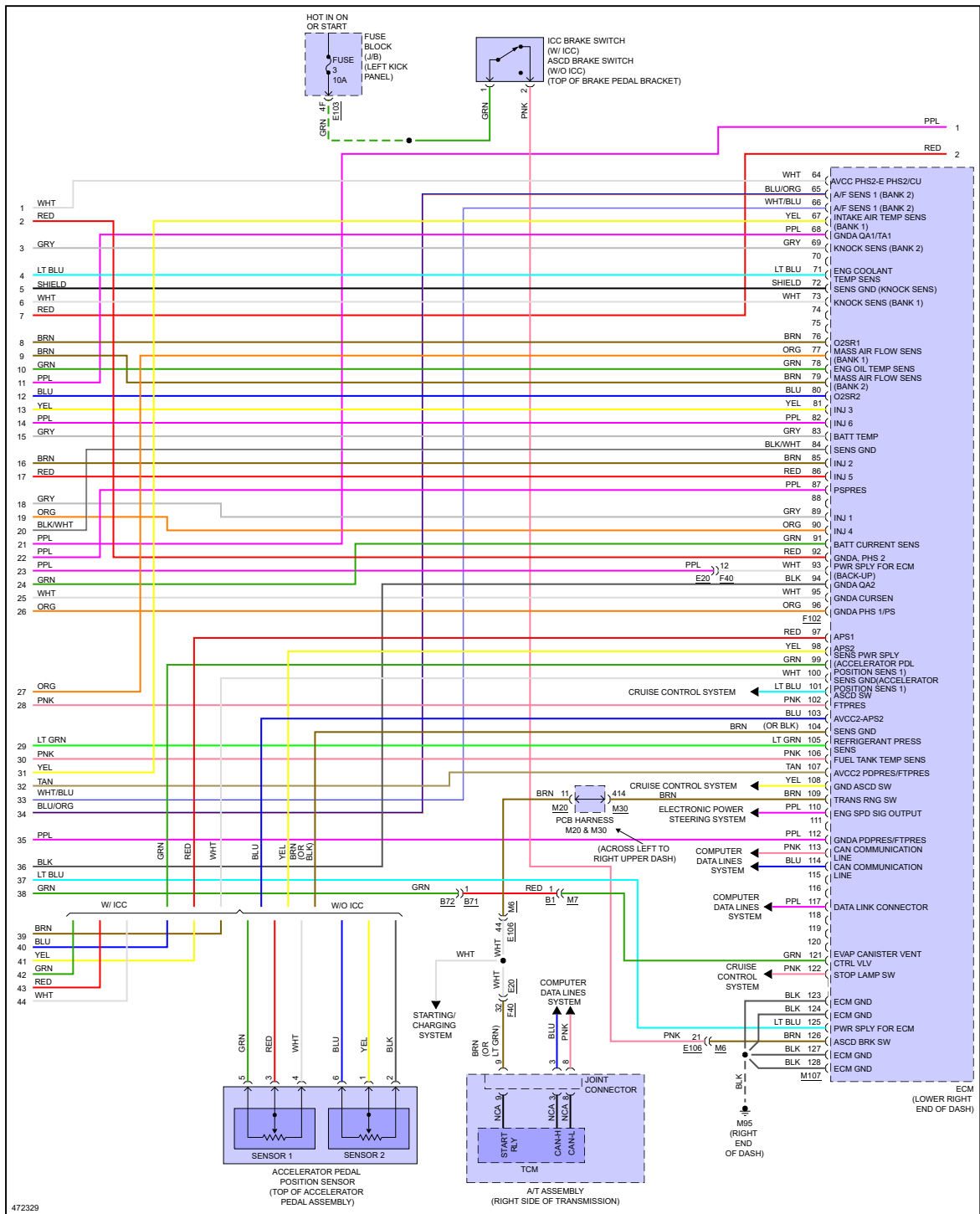
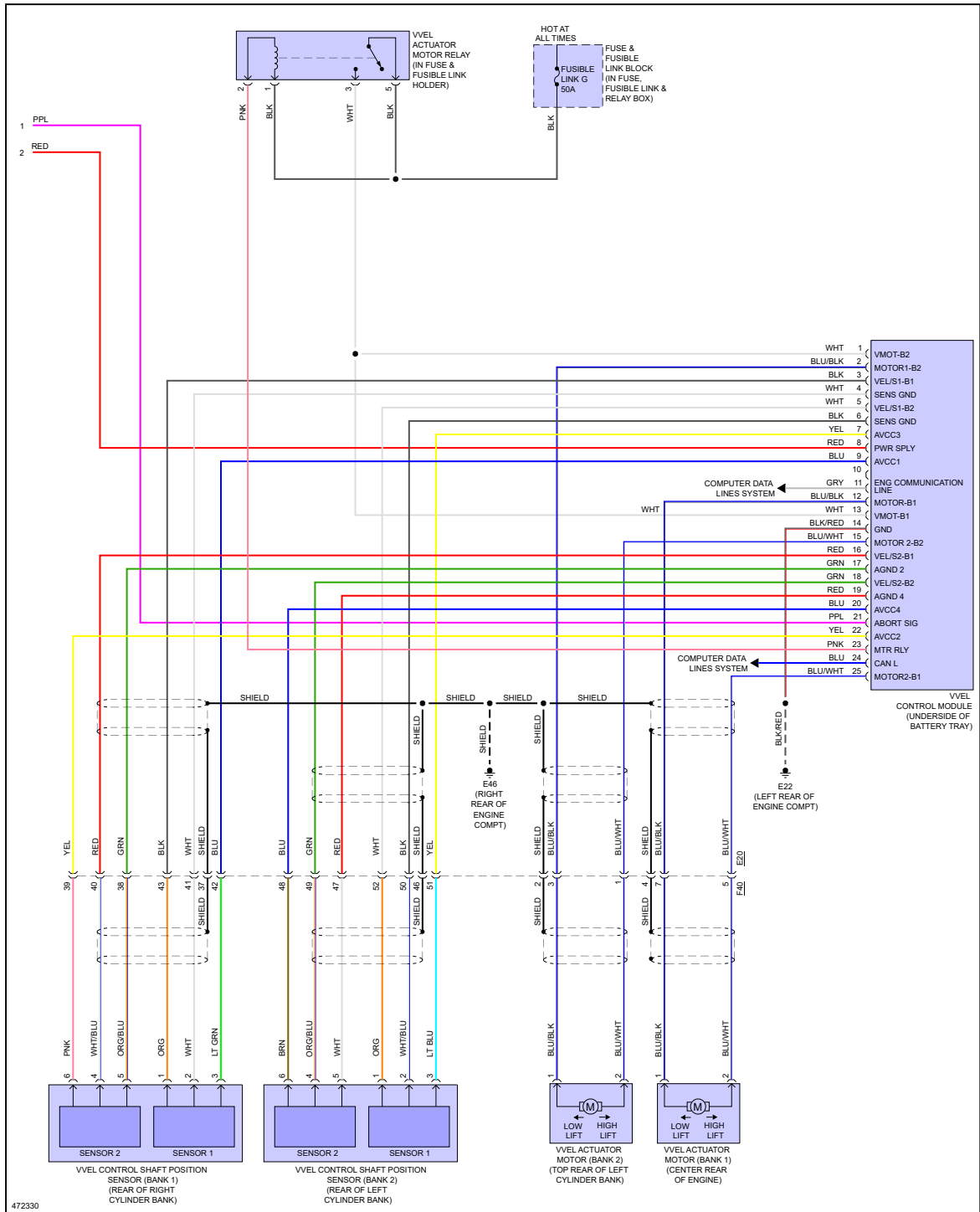

Fig 6: 3.7L, Engine Performance Circuit (6 of 6)



"If your car is beat down, bring it to P-Town!"