

P-Town Auto & Offroad, LLC

688 Harshaw Ave.
Patagonia, AZ 85624
(520) 394-0181 T

YMMS: 2018 Volkswagen Jetta GLI

Engine: 2.0L Eng

VIN:

May 13, 2024

License:

Odometer:

ENGINE PERFORMANCE > 2.0L TURBO

Fig 1: 2.0L Turbo, Engine Controls Circuit (1 of 6)

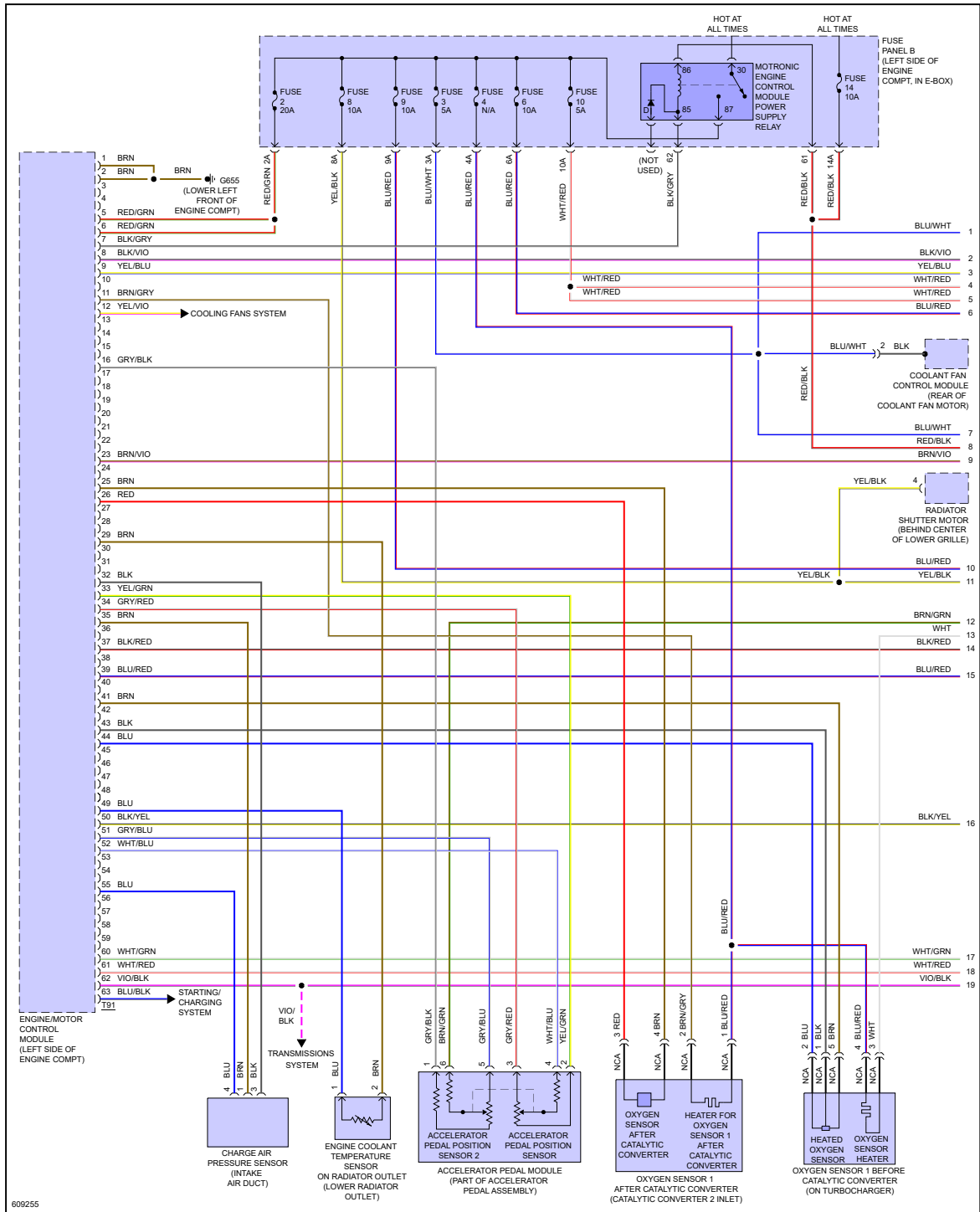

Fig 2: 2.0L Turbo, Engine Controls Circuit (2 of 6)

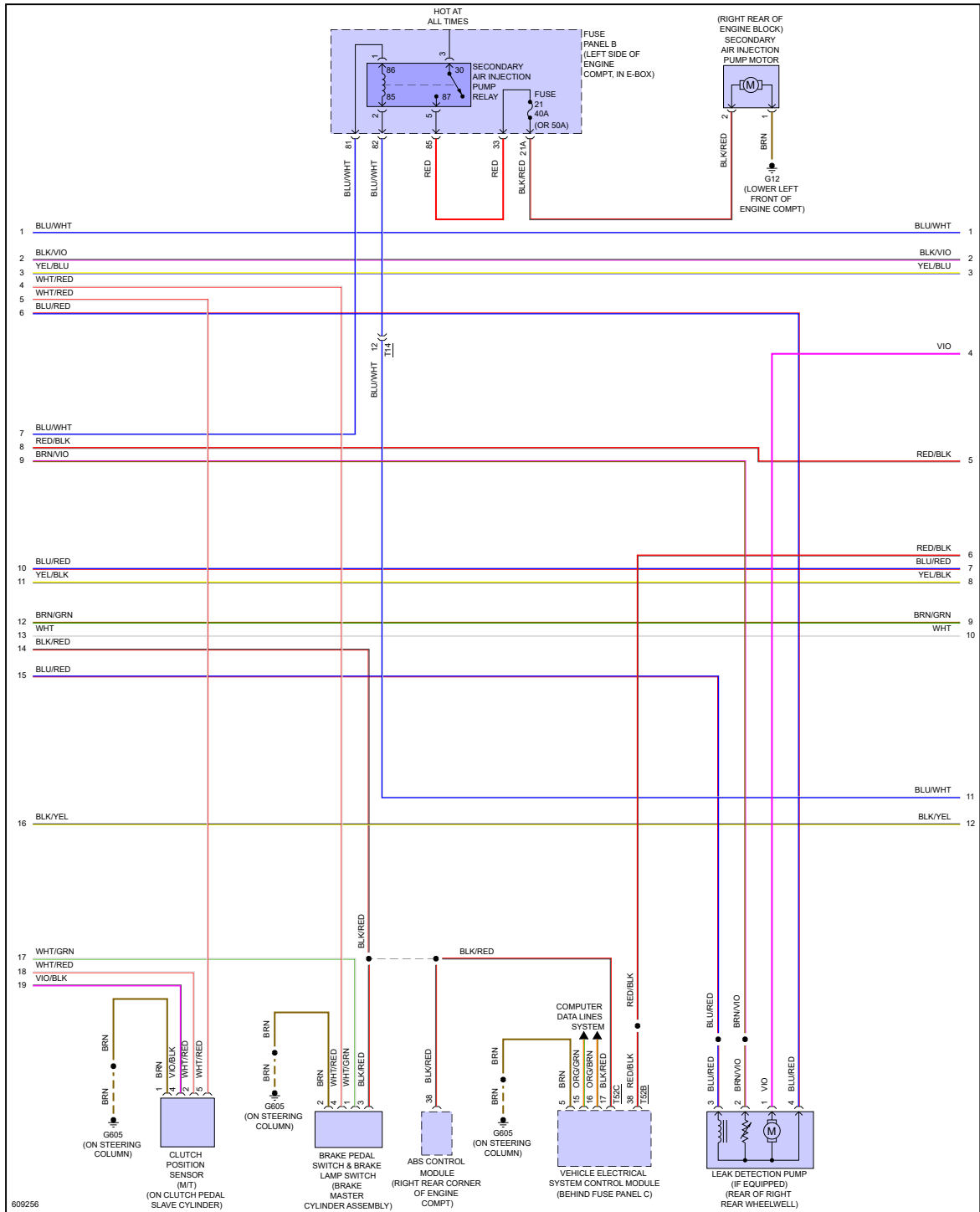

Fig 3: 2.0L Turbo, Engine Controls Circuit (3 of 6)

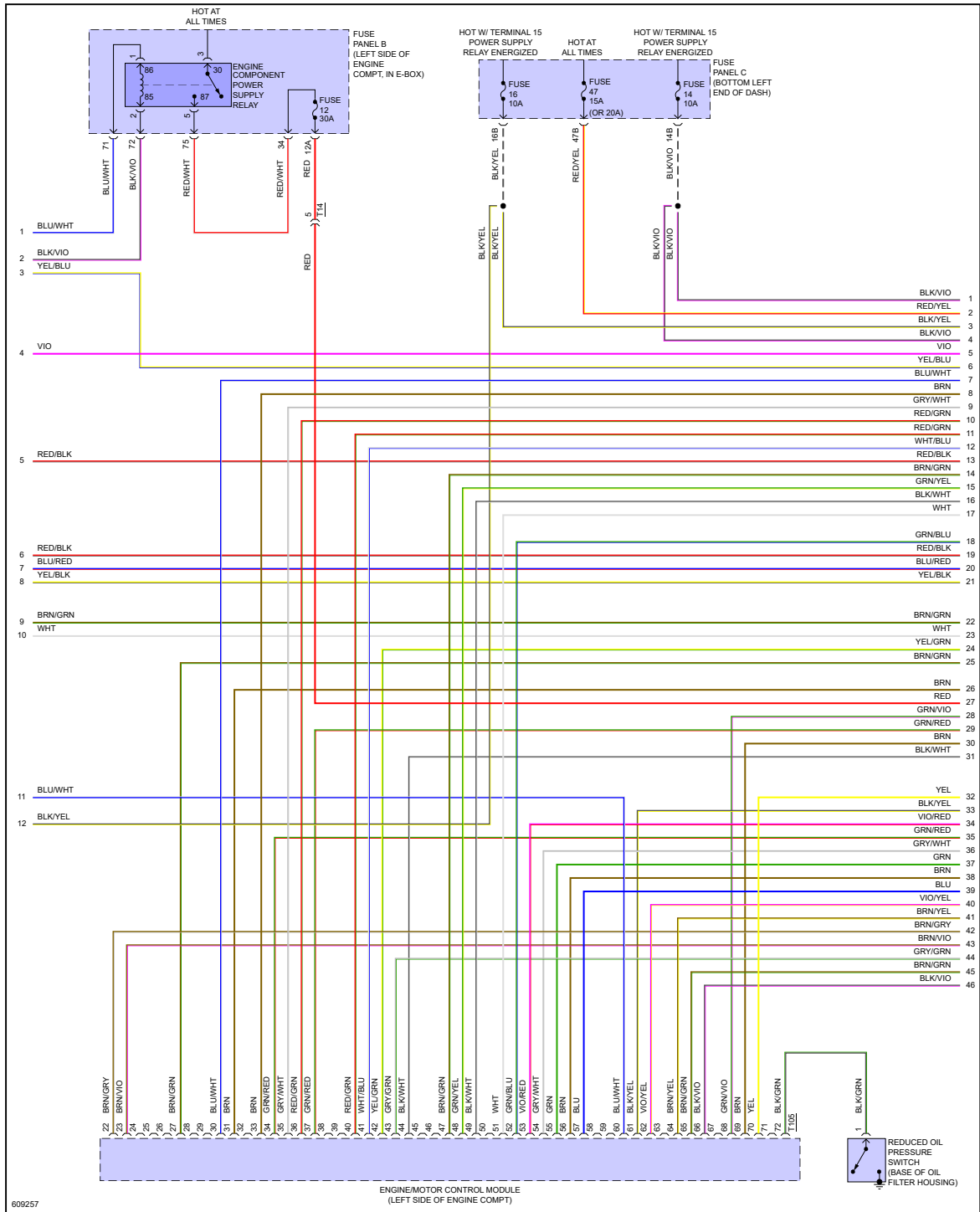
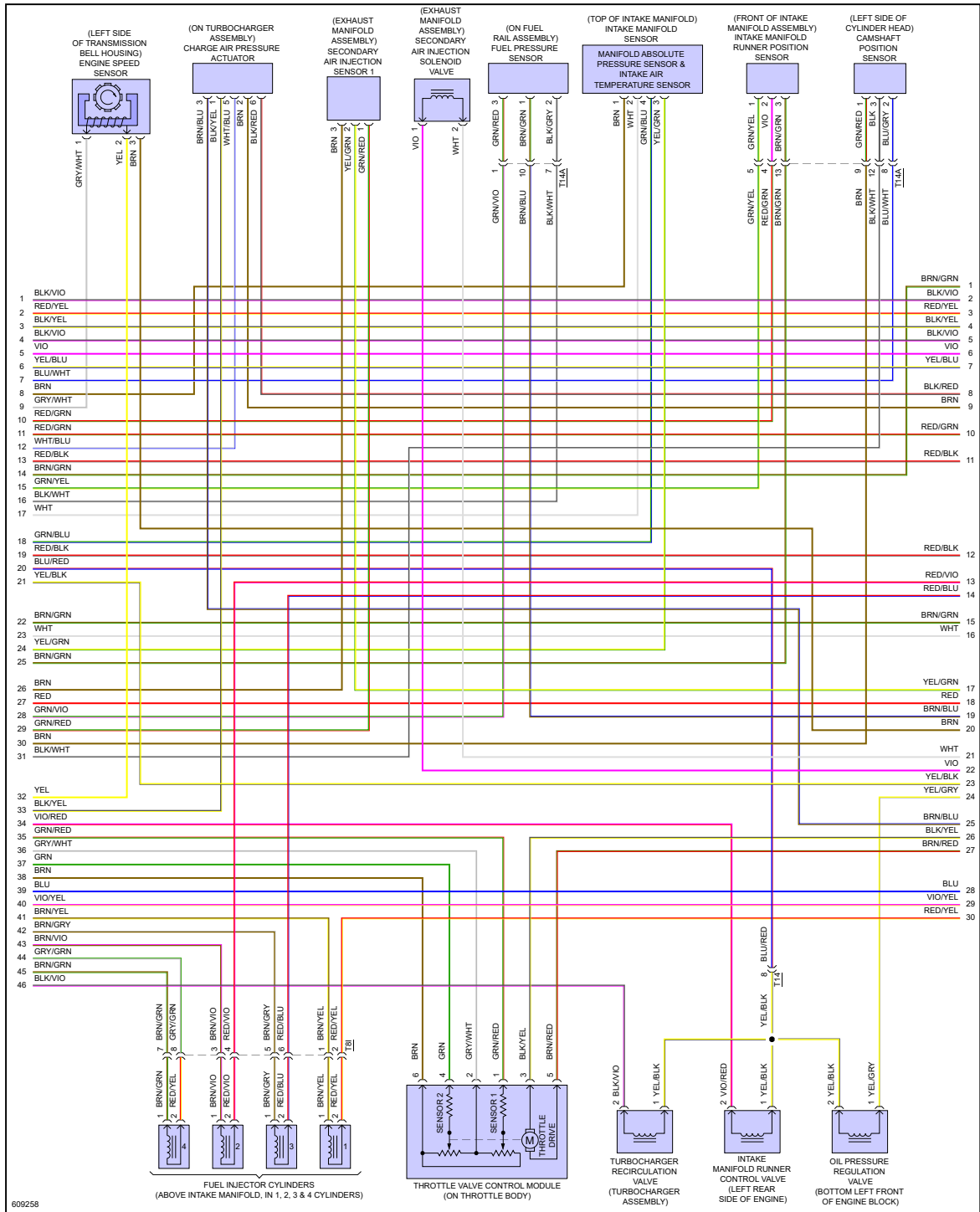
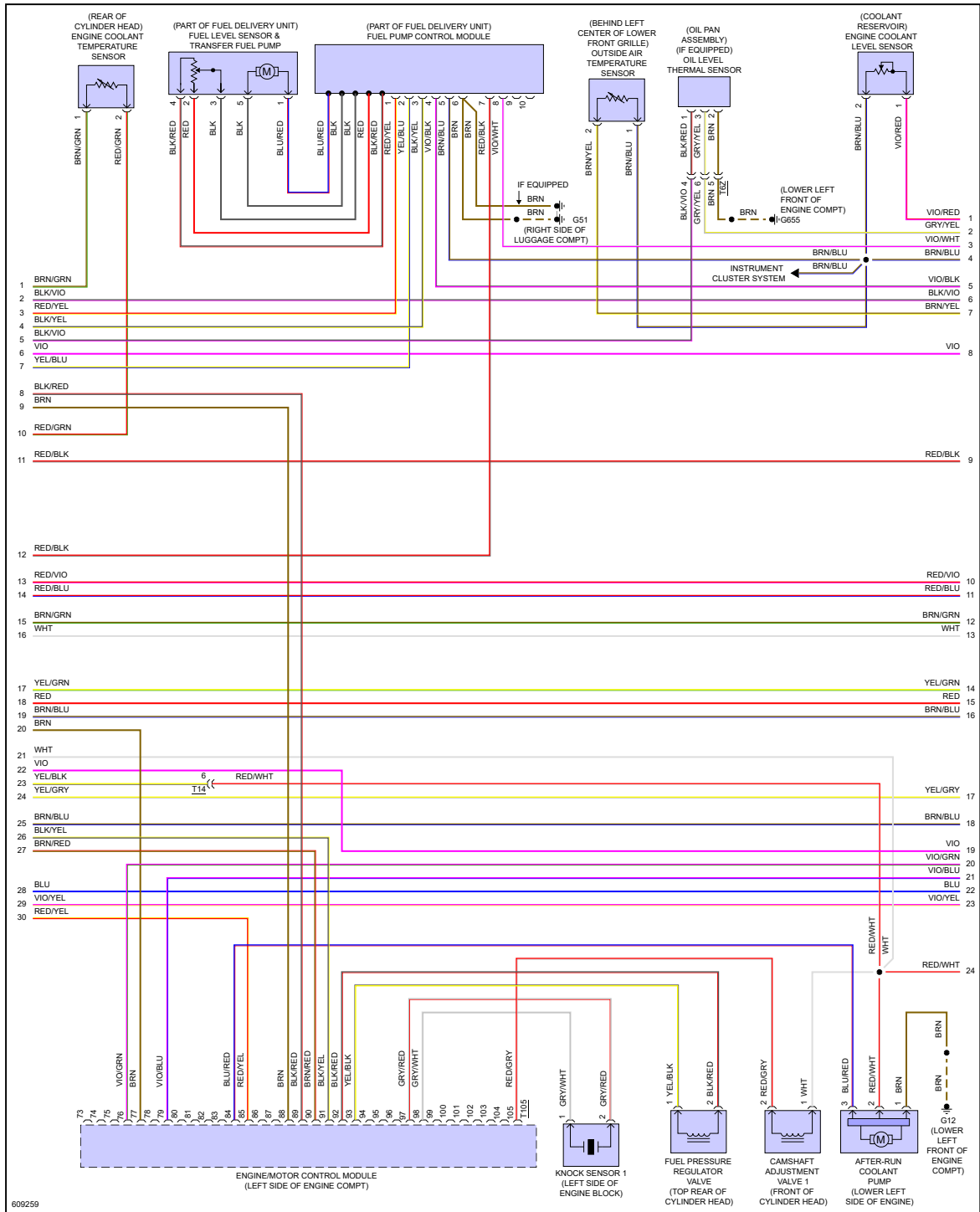

Fig 4: 2.0L Turbo, Engine Controls Circuit (4 of 6)



609258

Fig 5: 2.0L Turbo, Engine Controls Circuit (5 of 6)



609259

Fig 6: 2.0L Turbo, Engine Controls Circuit (6 of 6)

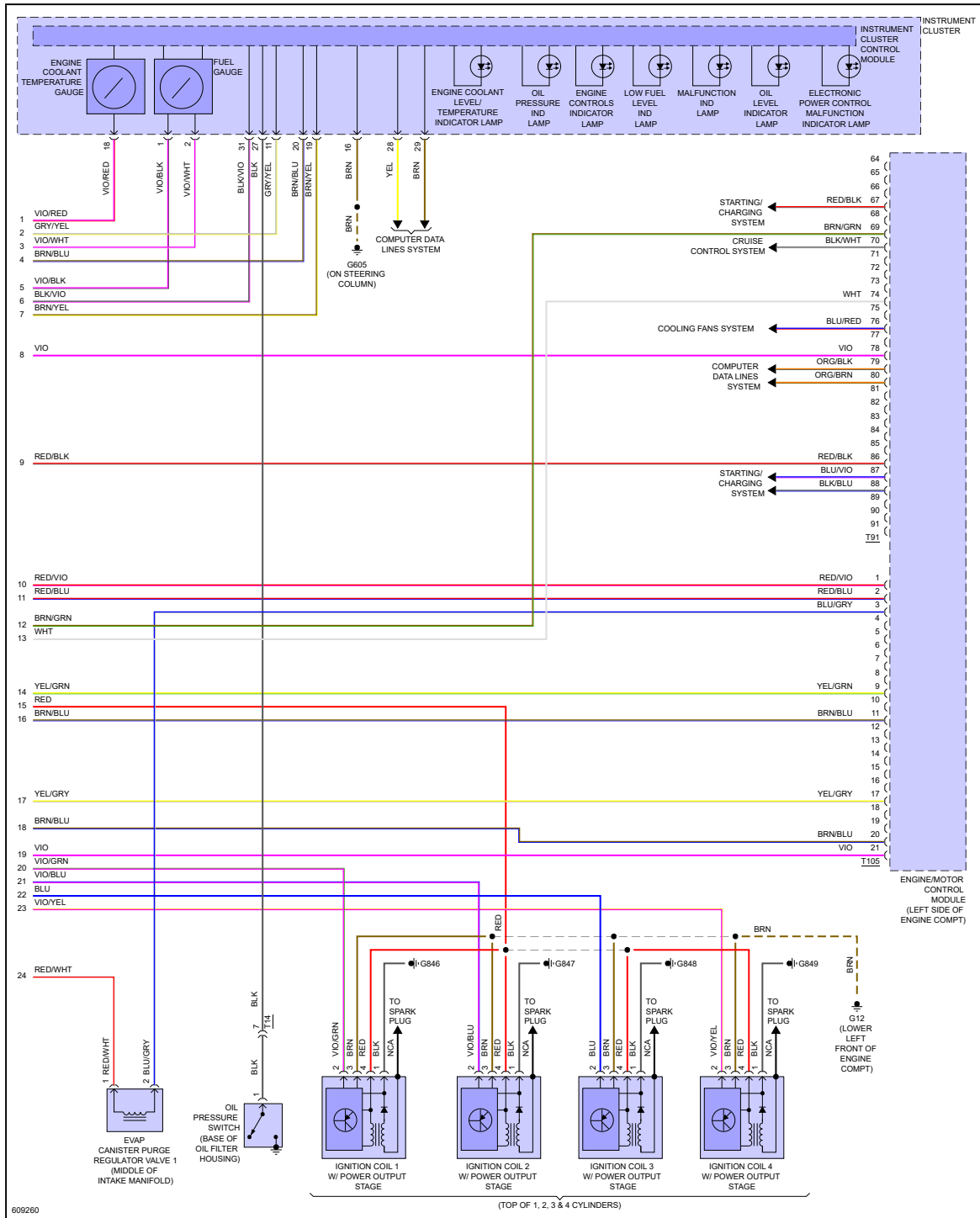
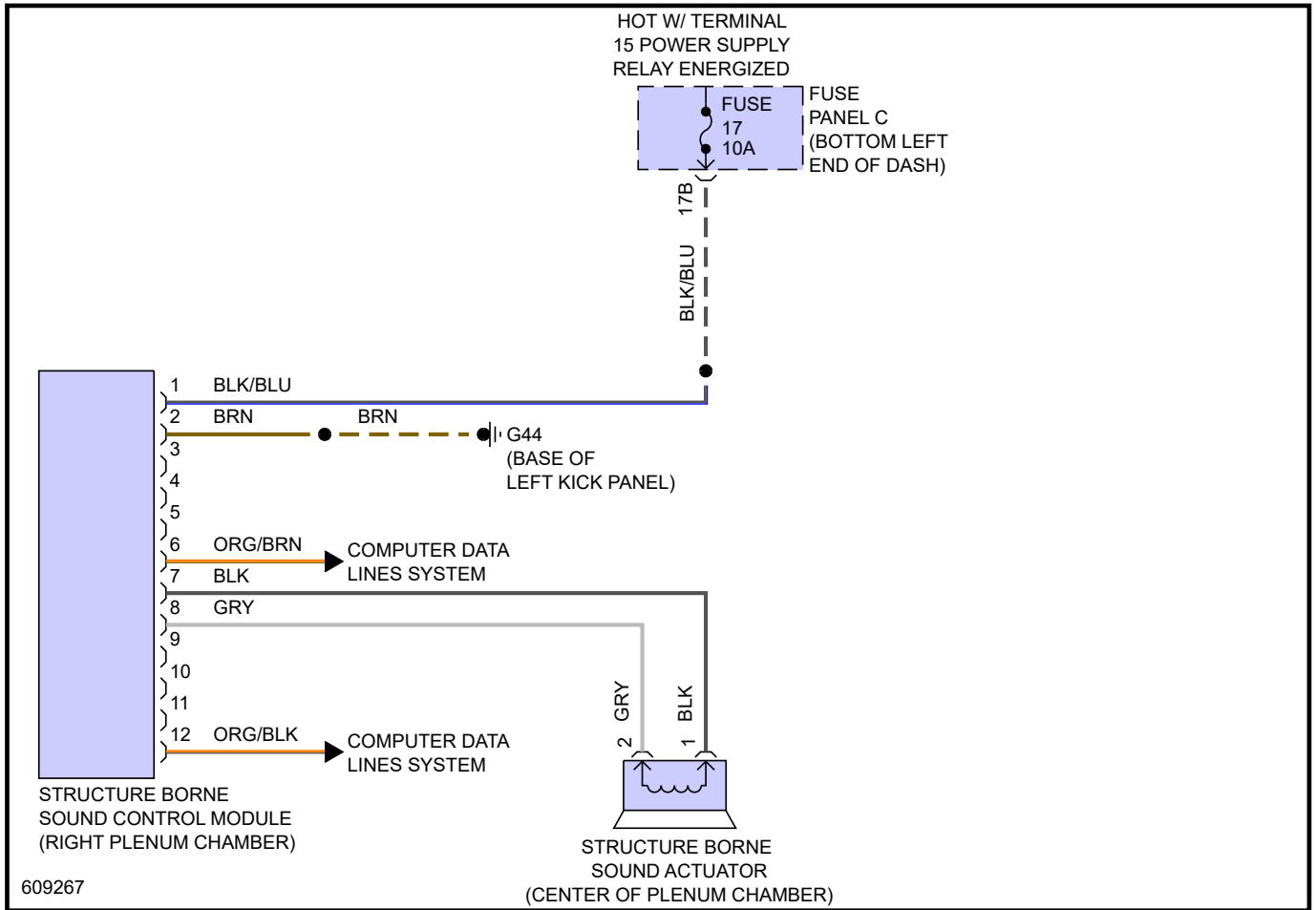

Fig 7: 2.0L Turbo, Structure Borne Sound Actuator Circuit



"If your car is beat down, bring it to P-Town!"