

P-Town Auto & Offroad, LLC

688 Harshav Ave.
Patagonia, AZ 85624
(520) 394-0181 T

YMMS: 2008 Nissan 350Z
Engine: 3.5L Eng
VIN:

Aug 22, 2024

License:
Odometer:

ENGINE PERFORMANCE > 3.5L

Fig 1: 3.5L, Engine Performance Circuit (1 of 6)

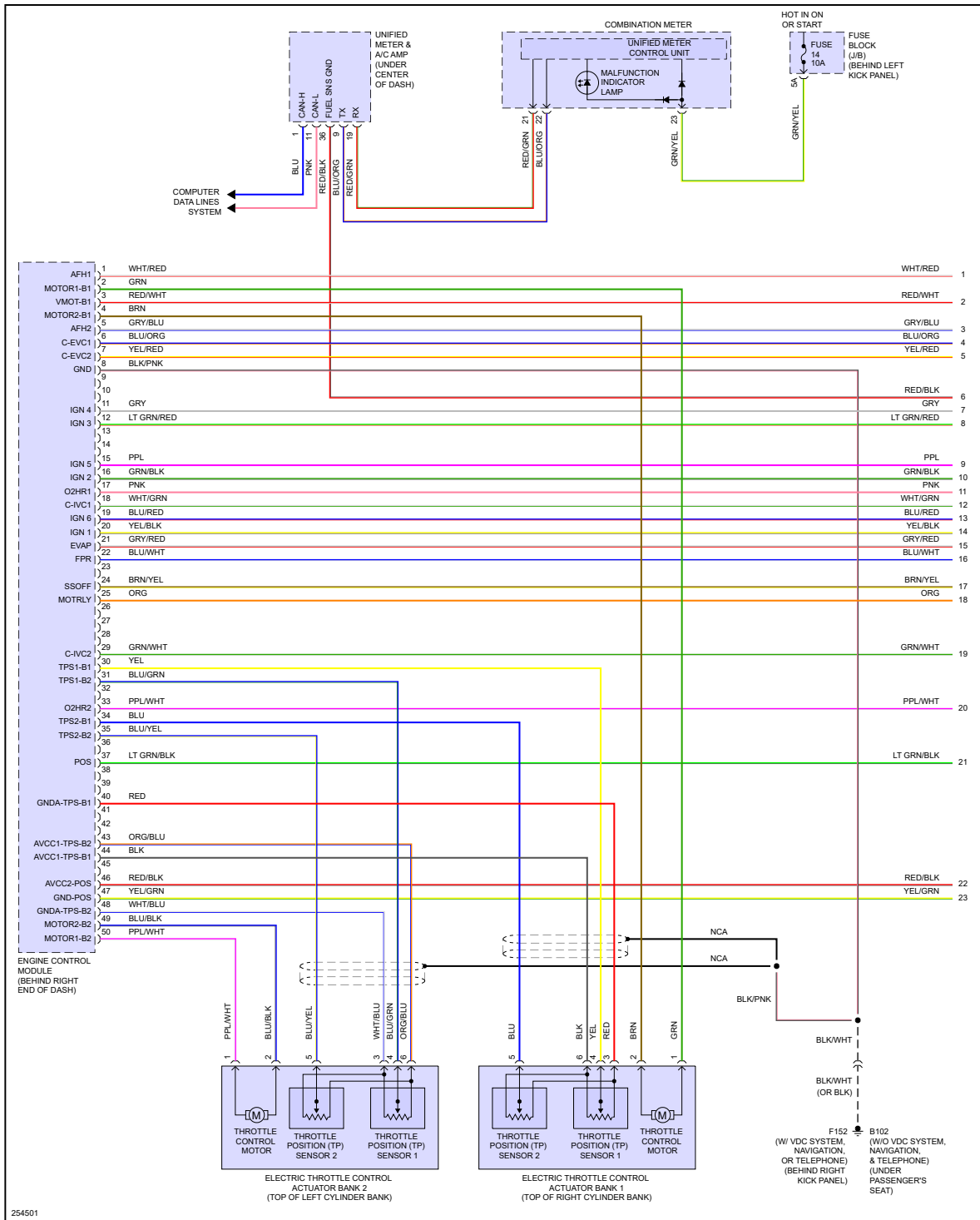

Fig 2: 3.5L, Engine Performance Circuit (2 of 6)

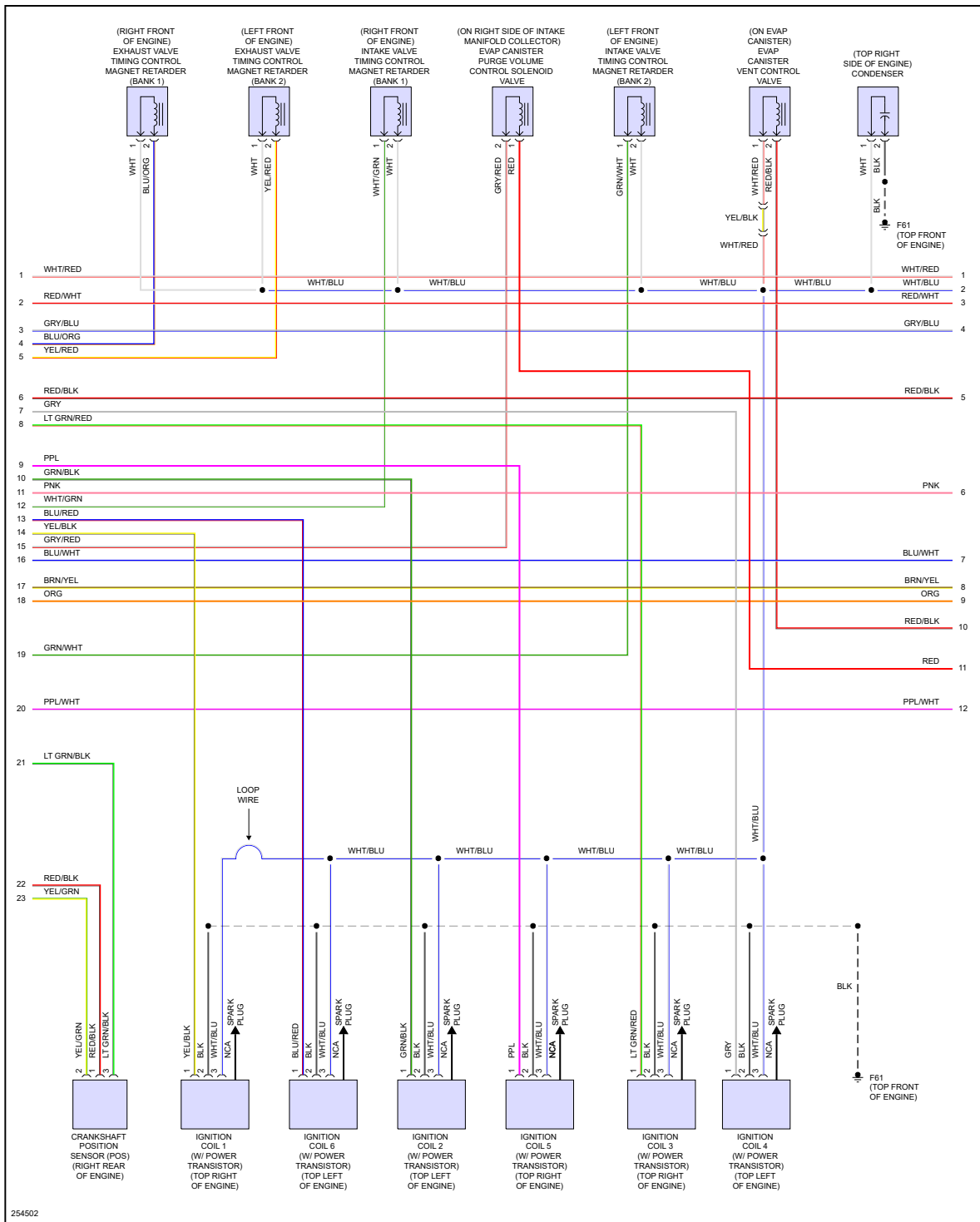

Fig 3: 3.5L, Engine Performance Circuit (3 of 6)

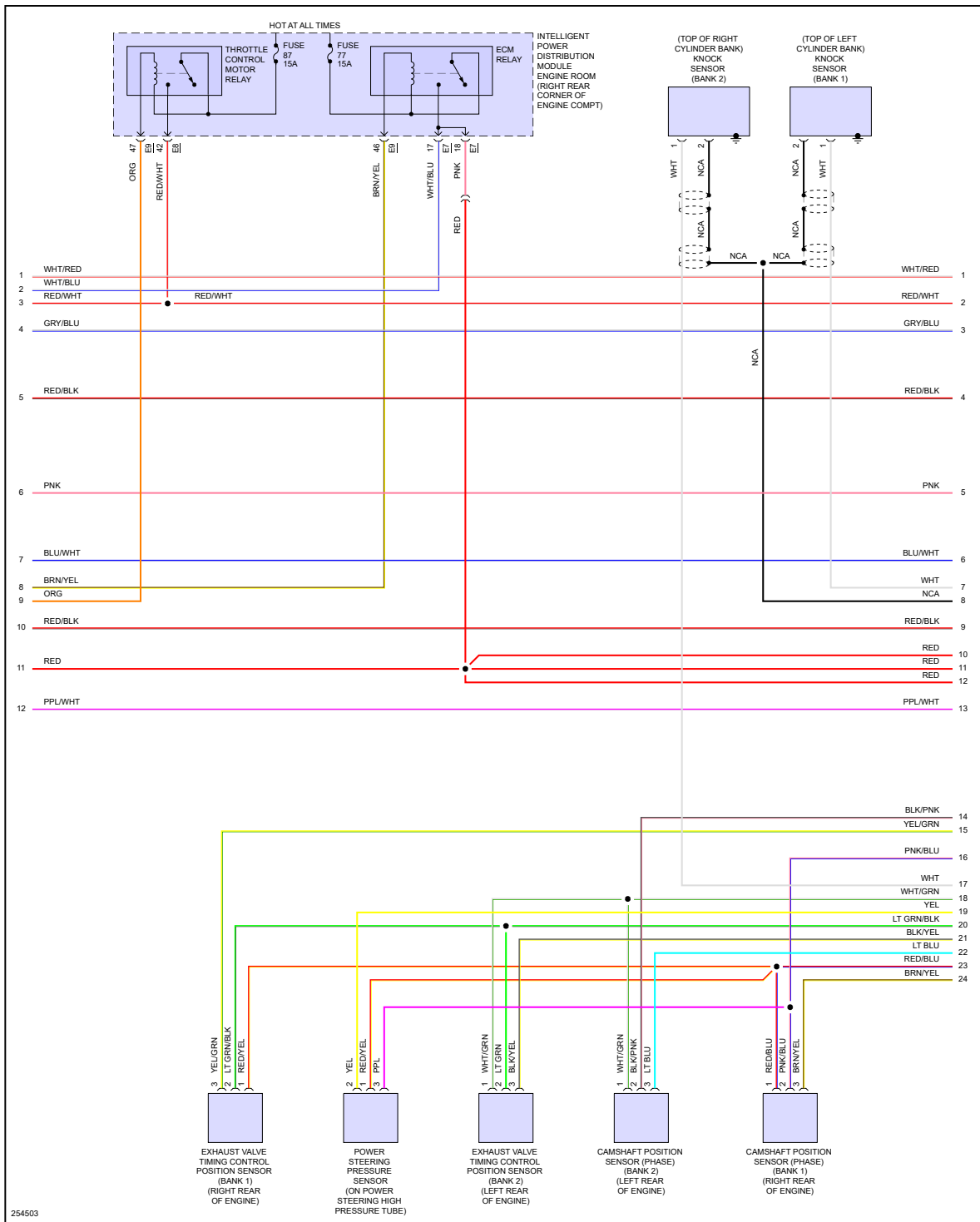

Fig 4: 3.5L, Engine Performance Circuit (4 of 6)

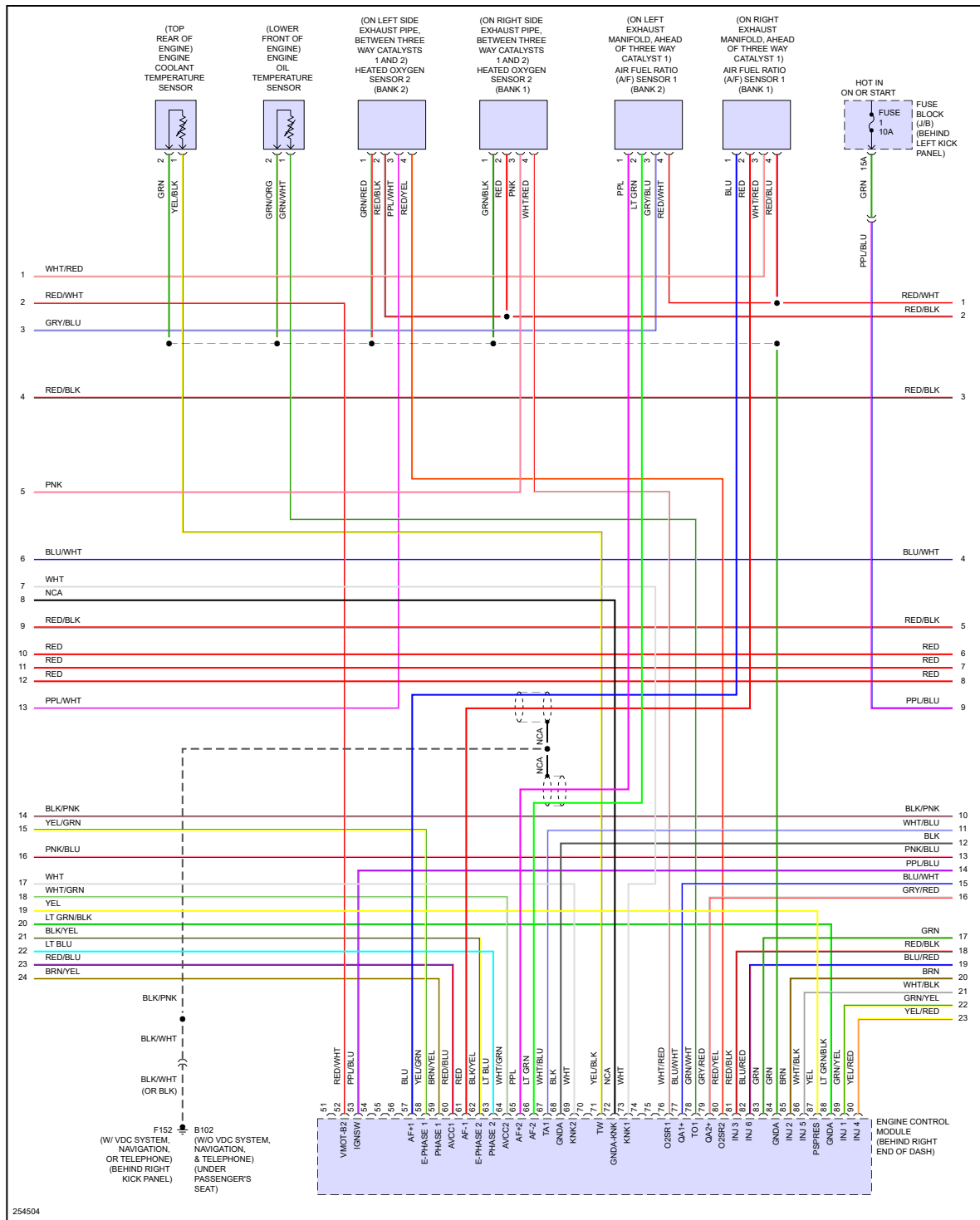

Fig 5: 3.5L, Engine Performance Circuit (5 of 6)

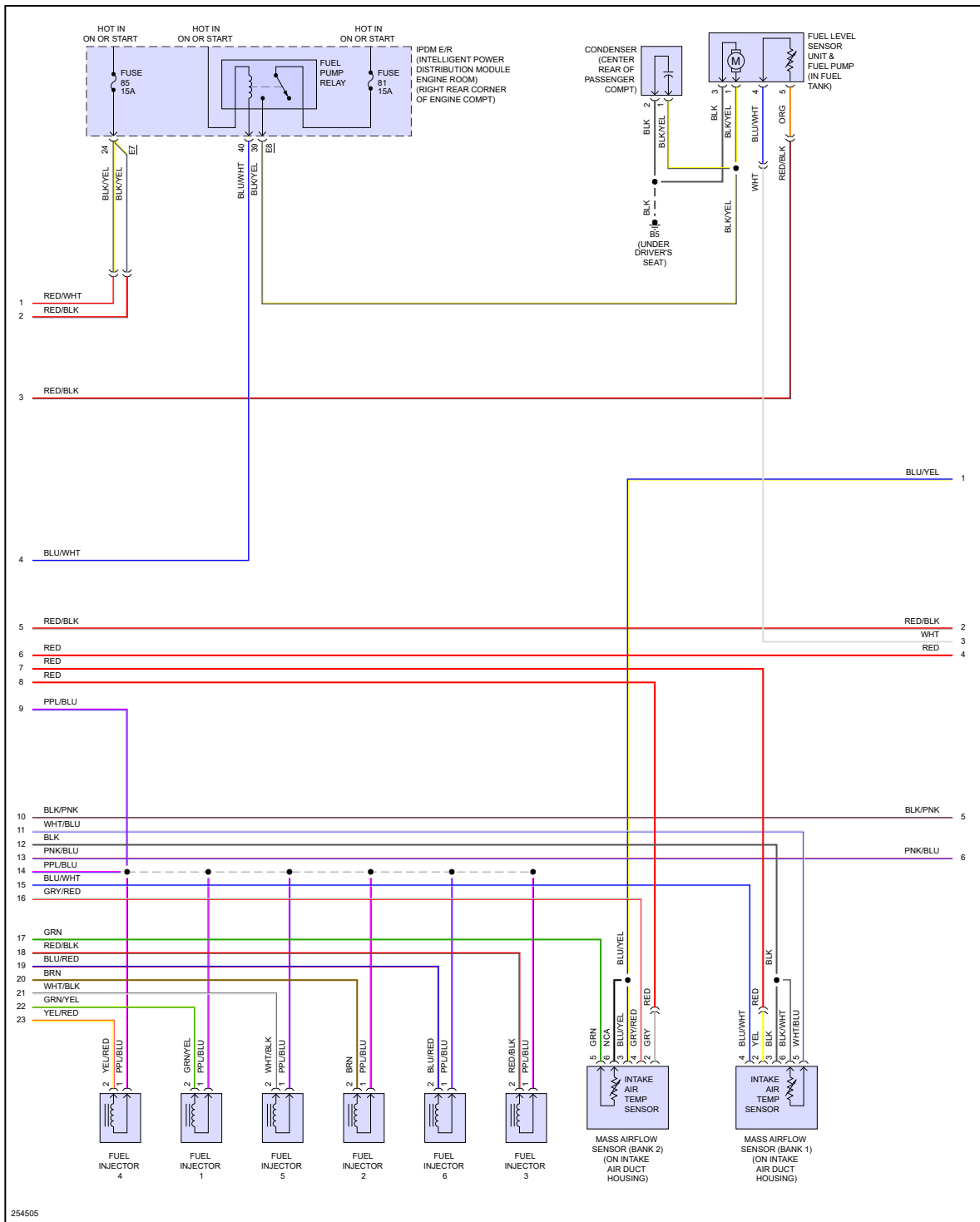
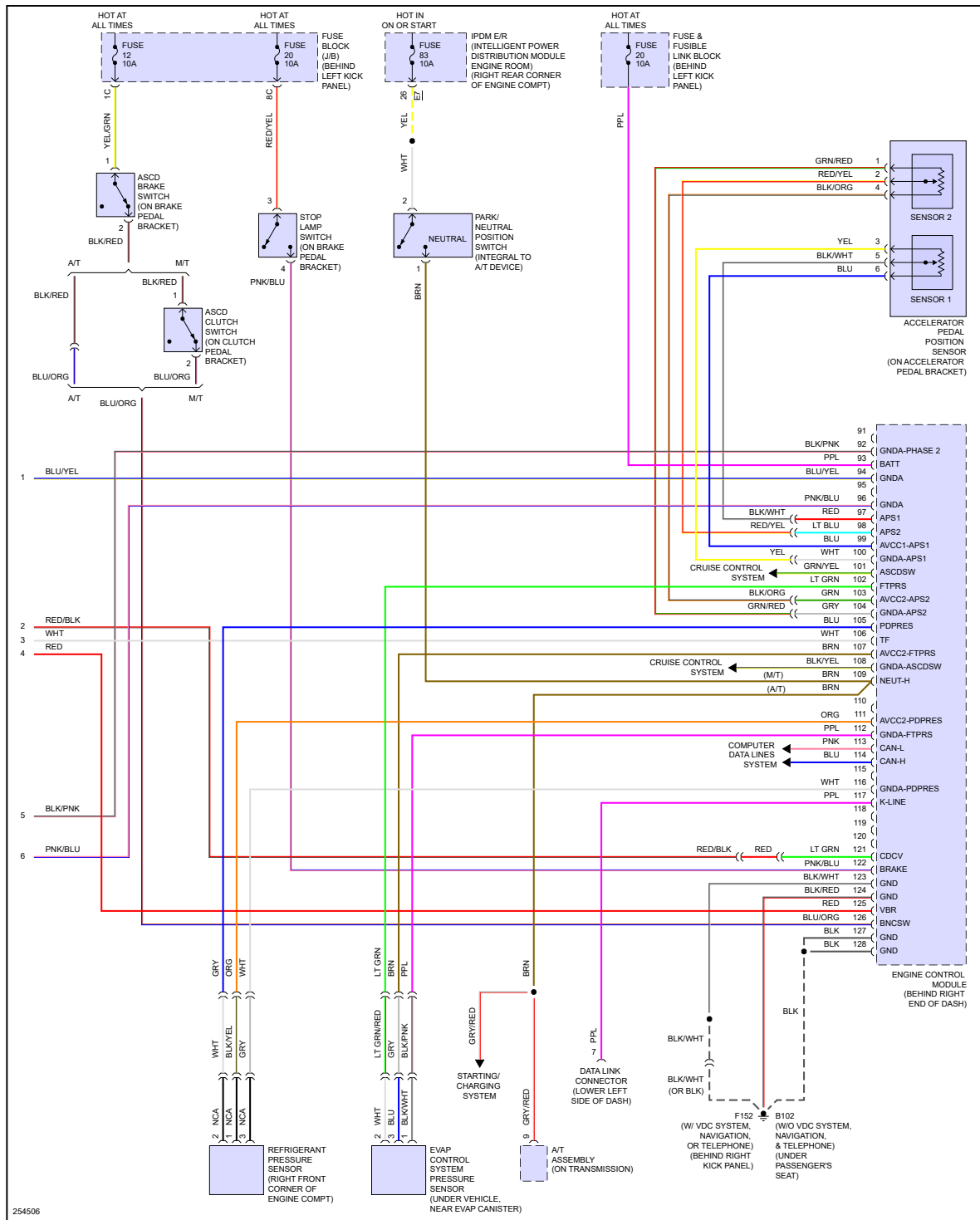

Fig 6: 3.5L, Engine Performance Circuit (6 of 6)



"If your car is beat down, bring it to P-Town!"