



## The 2017 Audi R8 Introduction

Audi of America, LLC  
Service Training  
Created in the U.S.A.  
Created 1/2016  
Course Number 990363  
©2016 Audi of America, LLC

All rights reserved. Information contained in this manual is based on the latest information available at the time of printing and is subject to the copyright and other intellectual property rights of Audi of America, LLC., its affiliated companies and its licensors. All rights are reserved to make changes at any time without notice. No part of this document may be reproduced, stored in a retrieval system, or transmitted in any form or by any means, electronic, mechanical, photocopying, recording or otherwise, nor may these materials be modified or reposted to other sites without the prior expressed written permission of the publisher. All requests for permission to copy and redistribute information should be referred to Audi of America, LLC.

Always check Technical Bulletins and the latest electronic service repair literature for information that may supersede any information included in this booklet.

## eMedia



This eSSP contains video links which you can use to access interactive media.

<b>Introduction</b> .....	<b>1</b>
Model history .....	2
Overview .....	4
<b>Body</b> .....	<b>8</b>
Introduction .....	8
Production of the R8 body .....	10
Audi lightweight design technology .....	12
Seating systems .....	18
<b>Occupant protection</b> .....	<b>20</b>
Overview .....	20
System overview .....	22
<b>Engines</b> .....	<b>24</b>
Specifications .....	24
Modifications to the 5.2l V10 engines .....	26
<b>Power transmission</b> .....	<b>42</b>
Overview .....	42
Selector mechanism .....	44
Transmission functions .....	46
Audi drive select – transmission setups .....	48
Emergency-releasing the parking lock .....	50
Transmission overview .....	52
Front final drive OD4 .....	56
Audi drive select – all-wheel drive configurations .....	63
<b>Chassis</b> .....	<b>64</b>
Overall concept .....	64
Axles and wheel alignment .....	65
Brake system .....	69
Steering system .....	72
Wheels and tires .....	74
<b>Knowledge assessment</b> .....	<b>76</b>

This eSelf Study Program teaches a basic knowledge of the design and functions of new models, new automotive components or technologies.

**It is not a Repair Manual! All values given are intended as a guideline only.**

For maintenance and repair work, always refer to the current technical literature.



**Note**



**Reference**



**In its second generation, the high-performance sports car has been newly developed from the ground up.**

The mid-engine principle used for the Audi R8 is not only a classic concept in motorsport but also an important piece of Audi tradition. The powerful engines were located in front of the rear axle even in the Grand Prix race cars brought to the start line by Auto Union in the 1930s – a revolutionary step at the time.

With the new Audi R8, our engineers are bringing accumulated racing expertise from the race track onto the road. The multi-material Audi Space Frame is the key factor behind the consistent lightweight design of the new Audi R8.

It is extremely light and rigid, while being acoustically comfortable and offering a high level of safety. The body shell features a completely new multi-material lightweight construction concept.

Carbon fiber reinforced polymer (CFRP) forms the 'B' pillars, the center tunnel and the rear bulkhead. The front end, roof arch and vehicle rear are formed by a framework of cast aluminum nodes and aluminum profiles.

A cockpit positioned very far forward, a long, flowing back and a relatively short wheelbase – the exterior design makes the technical concept of the mid-engine, high-performance Audi R8 clear upon first sight. The car's proportions convey more of a race car character, with design ideas from the previous model now more pronounced.

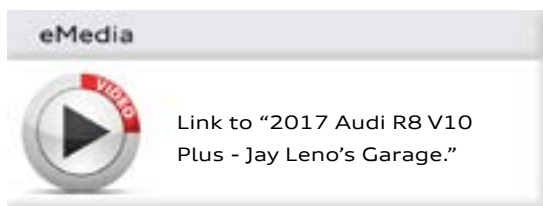

641\_002

## Learning objectives for this eSelf-Study Program:

Once you have completed this eSelf-Study Program, you will be able to answer questions on the following topics:

- > New features of the multi-material body structure.
- > New features of the occupant protection system.
- > Modifications to the 5.2l V10 FSI engine.
- > New power transmission features.
- > New chassis features.
- > Modifications to the electronics and to the driver assistance systems.
- > New features of the electrical and networking systems.
- > New remote control features.
- > Modifications to and new features of the infotainment system.

## Model history

In the year 2000 Audi won the Le Mans 24 hours endurance race for the first time with its LMP prototype R8. From then until 2005, the model which gave its name to today's production high-performance sports car secured five overall victories on the Circuit de la Sarthe. The fact that Audi chose the name R8 for its road-going supercar reflects the technological relationship between the two winners.



641\_025

### Le Mans quattro study

The concept of a mid-engined sports car bearing the name Audi Le Mans quattro was unveiled at the Frankfurt Motor Show (IAA) in 2003.



641\_026

### First generation

The Audi R8 was launched on the market in April 2007 and initially available as a coupe powered by the 4.2l V8 FSI engine. From 2006 until the late 2014, a total of 26,037 Audi R8s were produced, including 6176 Spyders.



641\_027

### Second generation

The second generation of the Audi R8 continues the Audi tradition in mid-engine sports cars.

The Audi R8 shares the same platform as the Lamborghini Huracán produced in 2014.



641\_028

## Production at a new site

The new Audi R8 is being built in a specially constructed production facility known as the “Audi Böllinger Höfe” in Heilbronn not far from the Audi Neckarsulm plant. It is operated by quattro GmbH. Body manufacturing and final assembly both feature many new methods and are organized for flexibility – especially for a limited volume series with a handcrafted character. This offers the freedom to fulfill any individual customer requests.

As many as 500 highly qualified specialists are employed in the new R8 manufacturing facility. They build each car with handcrafted precision in 15 cycles, each lasting approximately 30 minutes. Before delivery, each new high-performance sports car must successfully complete a stringent quality acceptance process.



641\_030



641\_029



641\_005

## Overview

No other model from the brand with the four rings has a closer affinity to motorsport. None is more striking and more dynamic than the second generation of the high-performance R8.

It is characterized by a high-revving mid-engine as well as an extremely dynamic chassis with quattro drive system and fully variable torque control.

### Body

The Audi Space Frame (ASF) body features a new multi-material lightweight construction concept. Components made from carbon fiber reinforced polymer (CFRP) form the 'B' pillars, the center tunnel and the rear bulkhead. The front end, the roof arch and the rear are assembled from cast aluminum nodes and aluminum profiles which, in some cases, employ new alloys. Some components, such as the front splitter, the diffuser or the side blades are optionally available in clear-coated carbon fiber.

The R8 has been newly developed from the ground up. It is more taut, more striking and more fascinating both on the race track and on the road.

### Engines

Two versions of the 5.2l V10 engine are available. Both feature the cylinder-on-demand system.



### Chassis

Double wishbones made from aluminum guide all four wheels. With the Audi drive select dynamic handling system, the driver has the choice of four modes (comfort, auto, dynamic and individual) to control the way in which important technical components operate. As standard, the system incorporates the engine characteristics, steering, S tronic transmission and quattro drive system as well as optional extras such as Audi magnetic ride, the exhaust flaps and dynamic steering.

### Power transmission

The R8 uses the 7-speed dual clutch 0BZ transmission that features shift-by-wire technology. A launch control system allows full throttle acceleration from a standing start. Transmission characteristics can be personalized by the driver through Audi drive select. Power to the rear axle is through a mechanical limited-slip differential while power to the front is via a newly developed electro-hydraulic all-wheel-drive clutch.



## Displays and operation

Fully digital Audi virtual cockpit instrument cluster with dynamic animations and graphics. The start-stop and Audi drive select buttons are located on the multi-function steering wheel.

The steering wheel in the Audi R8 V10 plus has two additional buttons – one is for performance mode together with a rotary wheel for selecting the drive programs as well as a button for controlling the sports exhaust system. MMI navigation plus is installed as standard; the MMI touch wheel is the central controlling element.

## Headlights

Full LED headlights with the High beam assistant are standard equipment.



## Climate control

The three central operating elements of the climate control system appear to float weightlessly, underscoring the lightness of the instrument panel. The three-dimensional design of the air outlet vents brings to mind the air inlets of a race car.

## Assistance systems

The following systems are standard equipment:

- > Audi drive select
- > Electro-mechanical steering
- > Parking system plus

641\_003

## Dimensions

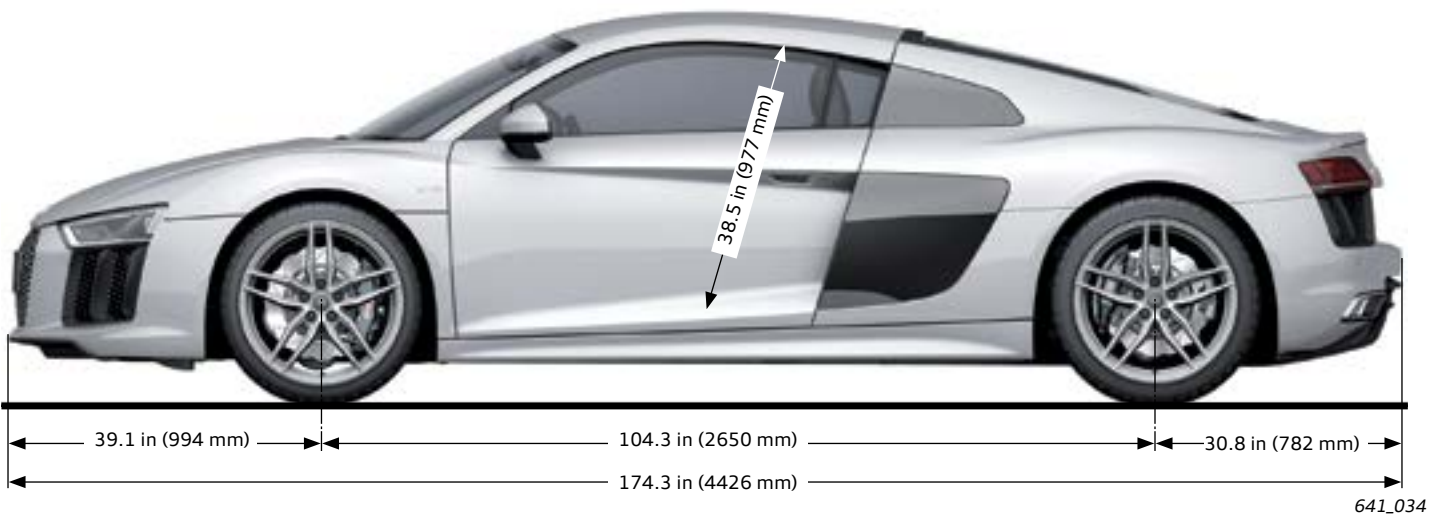
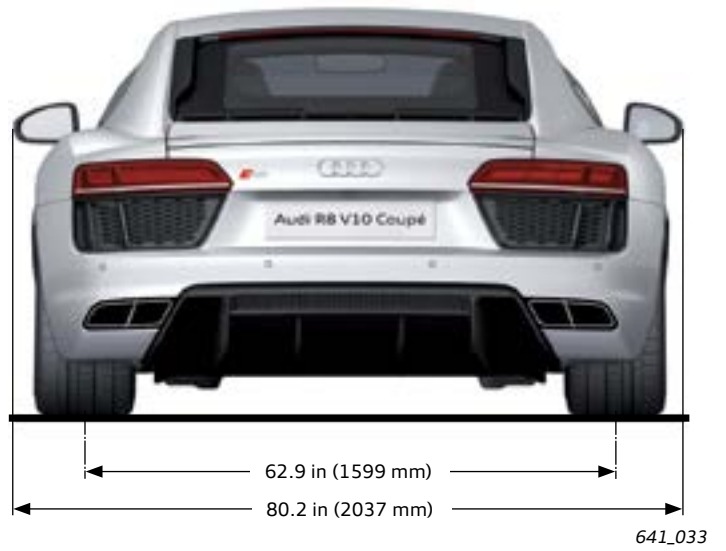
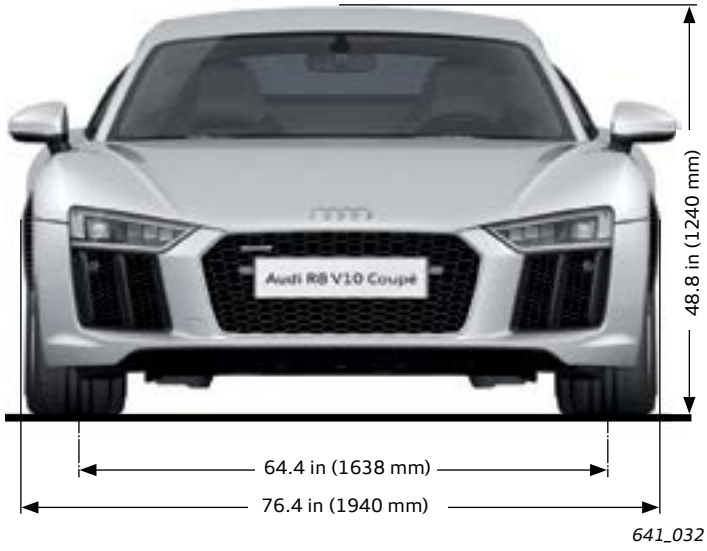

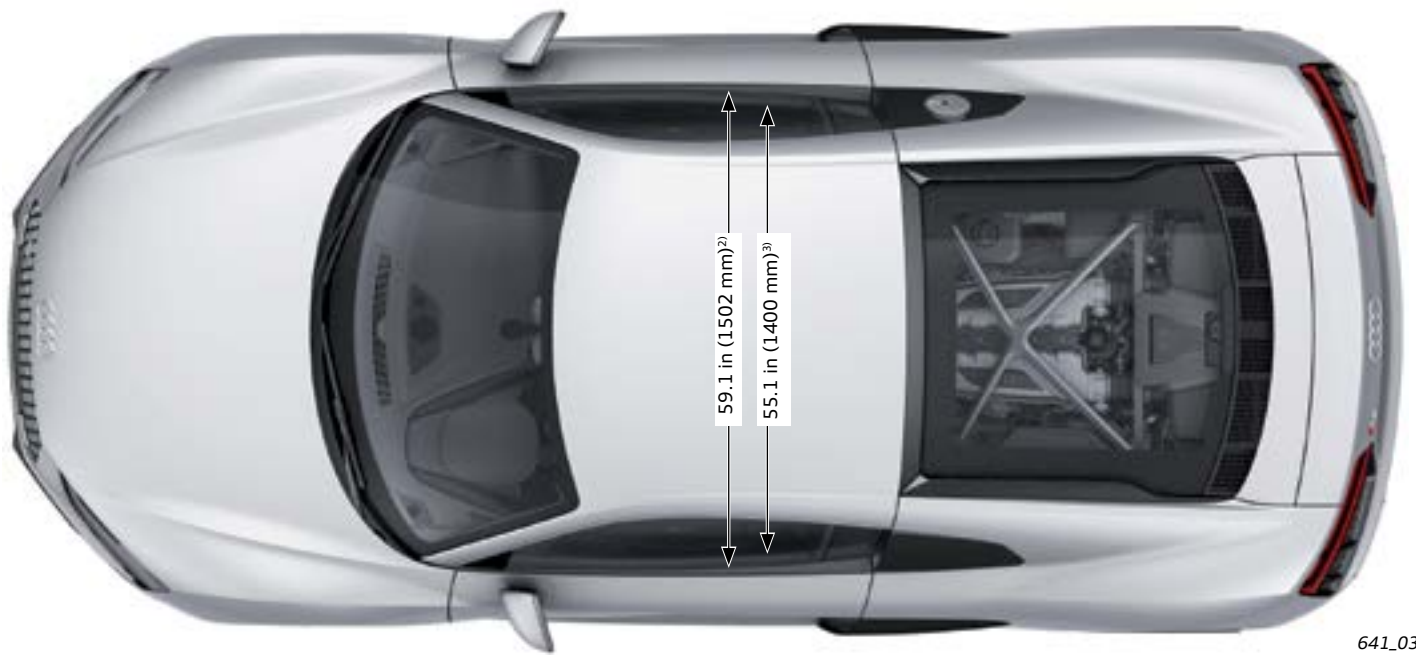

641\_035

## Exterior dimensions and weights

Length	174.3 in (4426 mm)
Width (not including exterior mirrors)	76.4 in (1940 mm)
Width (including exterior mirrors)	80.2 in (2037 mm)
Height	48.8 in (1240 mm)
Front track width	64.5 in (1638 mm)
Rear track width	62.9 in (1599 mm)
Wheelbase	104.3 in (2650 mm)
Curb weight	R8 V10 3516.3 lb (1595 kg) R8 V10 plus 3428.1 lb (1555 kg)
Gross vehicle weight	4111.6 lb (1865 kg)

## Inner dimensions and other specifications

Front cabin width	55.1 in (1400 mm) <sup>3)</sup>
Front shoulder width	59.1 in (1502 mm) <sup>2)</sup>
Luggage capacity	3.9 cu ft (112 l) / plus 7.9 cu ft (225 l) <sup>4)</sup>
Drag coefficient $c_w$	R8 V10 with adaptive rear spoiler retracted: 0.34 R8 V10 with adaptive rear spoiler extended: 0.35 R8 V10 plus with fixed rear wing spoiler: 0.36
Capacity of fuel tank	19.3 gal (73 l)

<sup>1)</sup> Maximum headroom

<sup>2)</sup> Elbow room width

<sup>3)</sup> Shoulder room width

<sup>4)</sup> Additional luggage space behind driver and front passenger seats

All dimensions given refer to the unladen weight of the vehicle.

# Body

## Introduction

The 2017 Audi R8 is based on the Modular Sportscar System (MSS). The MSS provides the body with high stability combined with low weight and represents an entirely new multi-material lightweight design concept.

This iteration of the Audi Space Frame (ASF) is very light and stiff. It offers occupants a high level of acoustic comfort and safety. The front end, roof frame and rear have a lattice design consisting of aluminum castings and extruded aluminum profiles. They are tailored specifically for their place and purpose.





In the event of a collision, the forces exerted on the side member structures are directed downwards and dissipated. For energy dissipation purposes, the side members should deform in a controlled manner and optimally transmit the residual energy to the next component.

When repairing this body, it is important to keep these defined deformation zones intact and to not disrupt the transfer of forces. To help ensure that this is the case after repair work, the depth of allowable repair and repair methods are defined in detail in the current repair literature.

## Body

The body consists of the inner structure and the roof outer skin. The structure is assembled from welded extruded aluminum profiles and aluminum castings.

### Key:

-  Sheet aluminum
-  Die-cast aluminum
-  Aluminum profile
-  Carbon fiber reinforced polymer (CFRP)

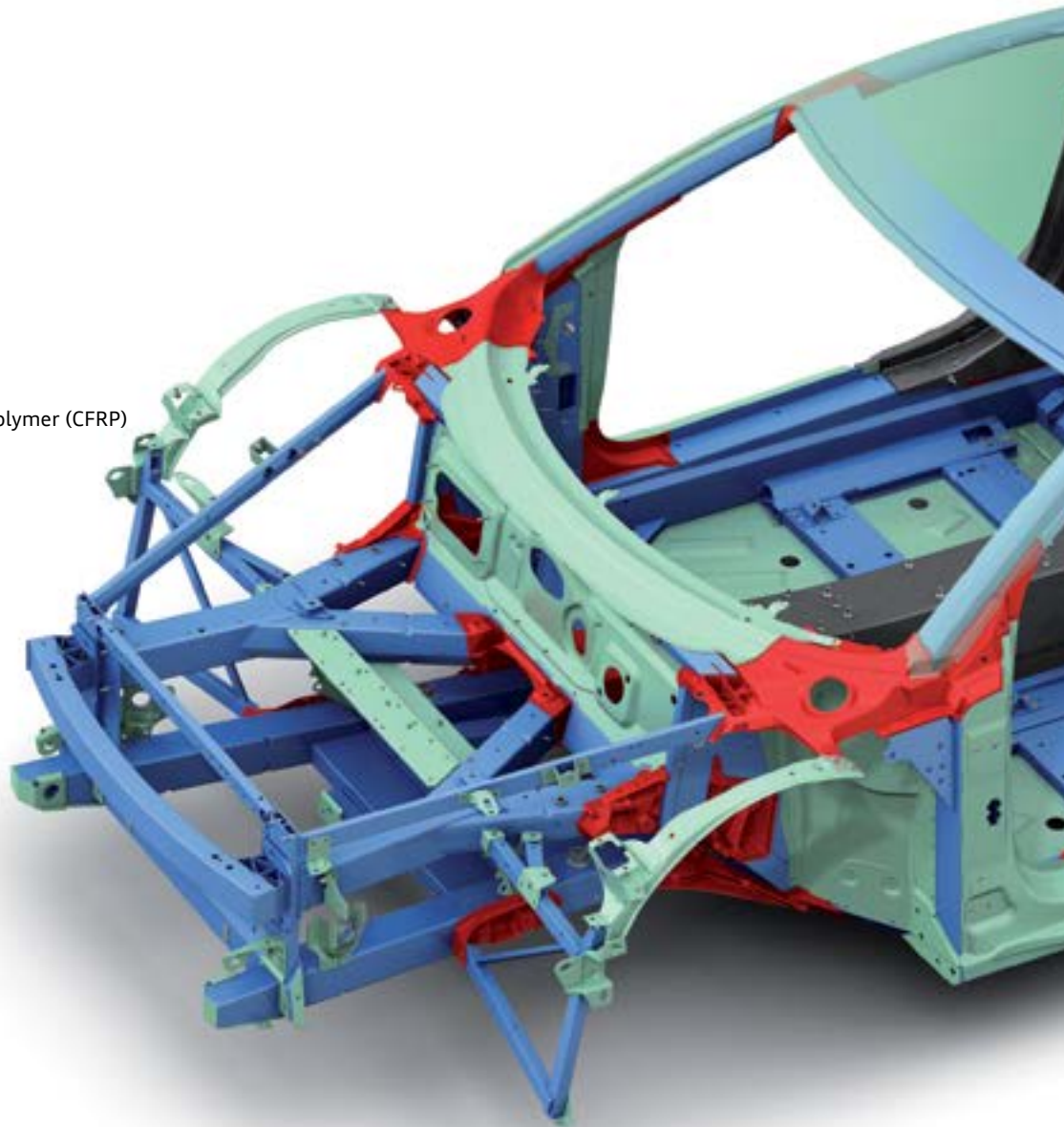

## Front end

The front end is made from extruded aluminum profiles and has aluminum castings for force absorption at the points where force is transferred to the vehicle interior.

## Carbon fiber reinforced polymer (CFRP)

Carbon fiber reinforced polymer (CFRP) is a modern and attractive composite material which fits in very well with the Audi lightweight design strategy. The material-specific advantages of CFRP are significant, particularly its weight to rigidity and strength ratios. The first generation of the R8 incorporated many large and small non-structural CFRP components that were attached to the aluminum structure, such as the side walls and the convertible top box lid of the R8 Spyder.

With the 2017 R8, Audi is using CFRP components made using the efficient RTM (Resin Transfer Molding) process for the first time.

In this process, the dry fiber rovings (twisted strands) are first shaped and then inserted into heated molds where an epoxy resin is injected under high pressure after closing the press. The fabric is completely saturated and hardened under pressure and controlled temperature.

Carbon fiber reinforced polymer is not only about 20% lighter than aluminum and 60% lighter than steel – but also gives designers the freedom to custom-design components to meet a variety of requirements.

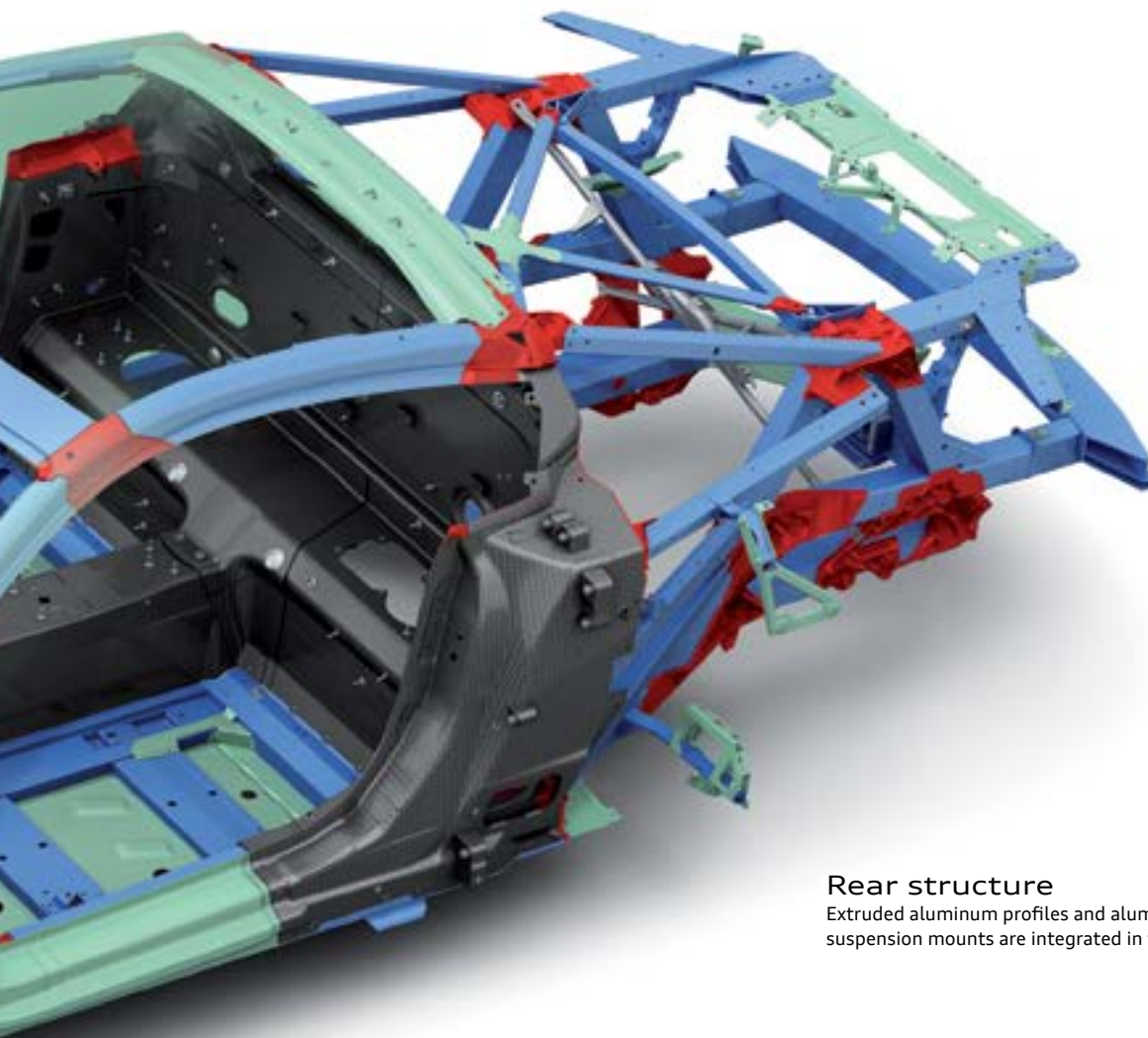

### Rear structure

Extruded aluminum profiles and aluminum castings form the rear. The suspension mounts are integrated in the castings.

### Center floor pan

The center floor pan is composed of the tunnel side members, the seat cross members and the floor panels. It is subsequently enclosed by the CFRP tunnel.

# Production of the R8 body

Due to the different temperature characteristics of aluminum and CFRP, the R8 body is manufactured in two stages.

## Stage 1

**Bodyshop 1 and the paint shop carry out the preliminary work on the bodyshell.**

First, the ASF structure is completed. The front end, center floorpan, rear and body are assembled and prepared for painting as a complete body with attachments. After this, the bodyshell passes through a dip bath in the paint shop. This process is referred to as "cataphoretic dip coating" (CDC) and protects the body against corrosion. Before the body can be painted the CFRP adhesive surfaces must be masked. The coated and masked body is now painted and dried and hardened at a temperature of over 392 °F (200 °C).

Because the CFRP components are only able to withstand temperatures of up to about 248 °F (120 °C) due to the epoxy resin, they are assembled subsequently. Another reason for taking this approach is that aluminum and CFRP have different coefficients of thermal expansion.

## Stage 2

**In Bodyshop 2 the bodyshell is completed together with the CFRP components.**

Stage 1 is followed by manual removal of the painted attachments and demasking of the surfaces. Accessibility for subsequent process steps is improved by removing the attachments (doors, rear hatch and body side sections). After cleaning the adhesive surfaces, the CFRP components are installed on the painted body and integrated into the structure using bonding, bolting and riveting methods.

A further process step after joining and placement of the rivet elements is the sealing of the CFRP structural components. Edges, rivets and rivet nuts are sealed with polyurethane (PU) to prevent the ingress of liquid and moisture into the joined components. After this, the body is stored for 6 hours at room temperature before being hardened in an oven at 176 °F (80 °C) for about 45 minutes.

## Joining techniques

Semi-tubular punch rivet

Bonding + pop riveting

Metric bolting

Bonding + metric bolting

Flow drill screws

Bonding + flow drill screws

TIG welding

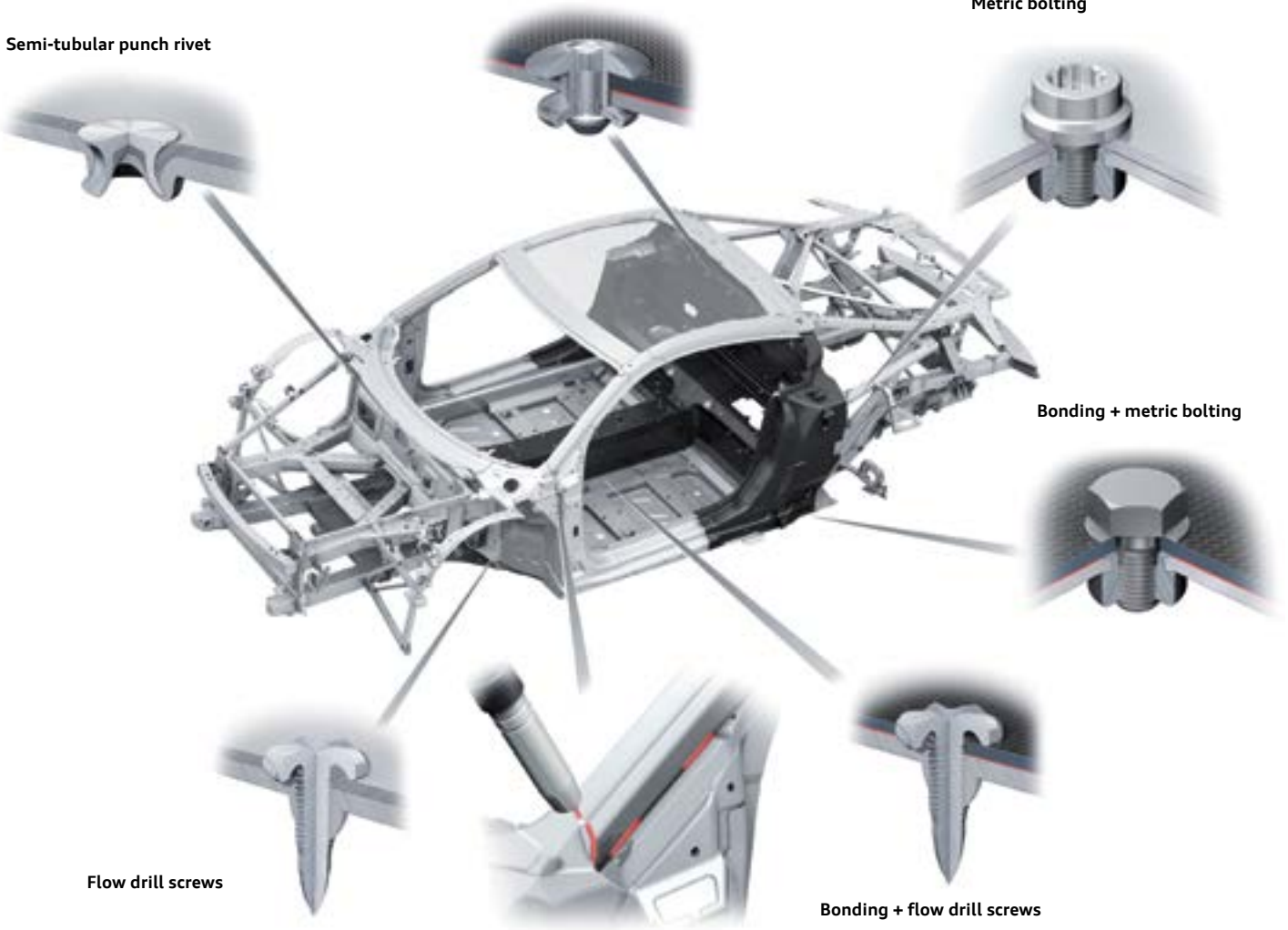

## CFRP components

### ① Rear bulkhead

The complex rear bulkhead is assembled from 17 CFRP components, two aluminum castings and two extruded aluminum profiles. It is bonded, riveted and bolted into the RB aluminum structure as a complete unit.

### ② Upper 'B' pillar

The CFRP upper 'B' pillars are bonded and riveted to the rear bulkhead providing additional support.

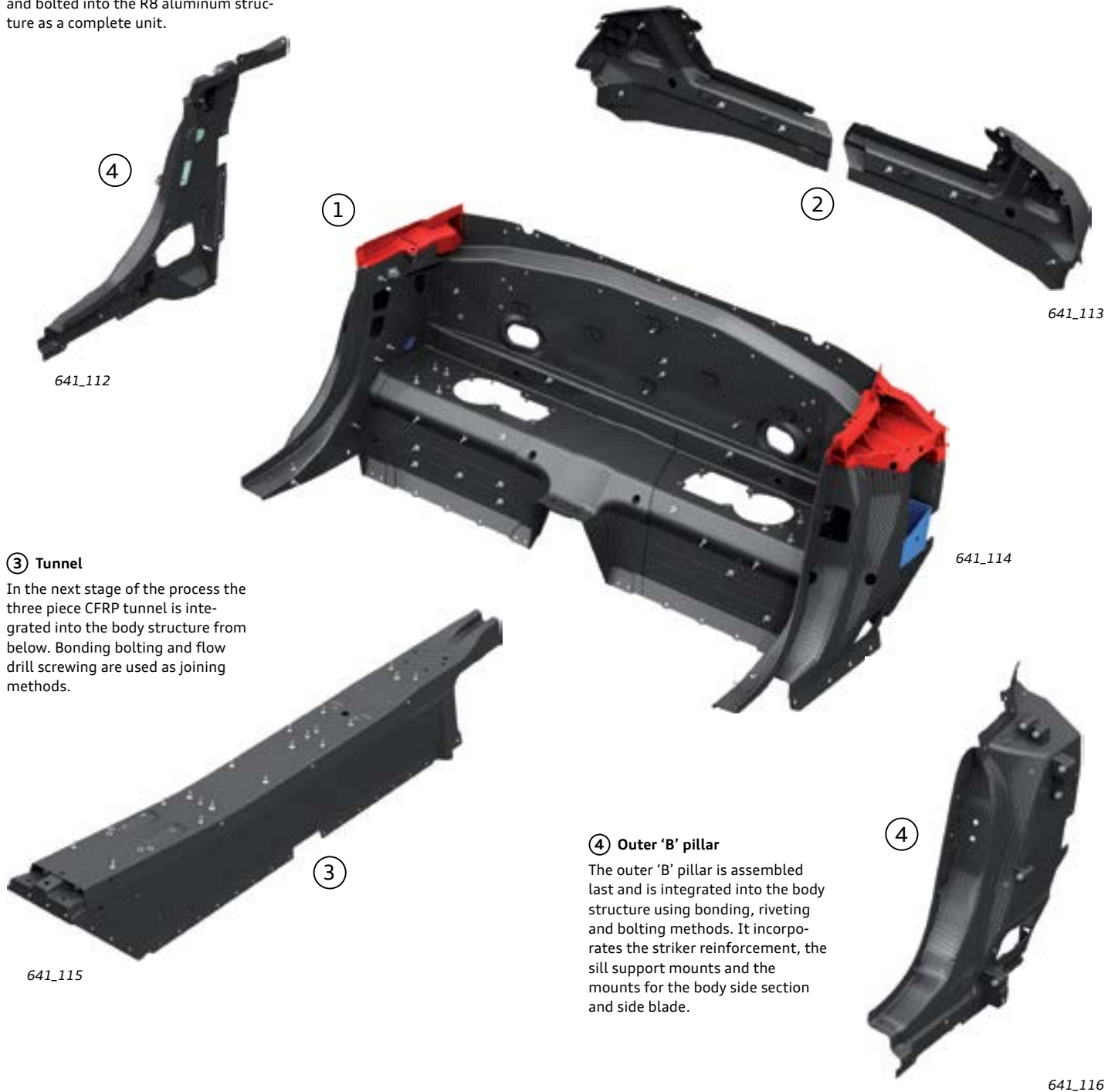

### ③ Tunnel

In the next stage of the process the three piece CFRP tunnel is integrated into the body structure from below. Bonding bolting and flow drill screwing are used as joining methods.

### ④ Outer 'B' pillar

The outer 'B' pillar is assembled last and is integrated into the body structure using bonding, riveting and bolting methods. It incorporates the striker reinforcement, the sill support mounts and the mounts for the body side section and side blade.

## Stage 1

## Stage 2

Bodyshop 1

CDC/paint

Bodyshop 2



# Audi lightweight design technology

At Audi, lightweight design technology applies the maxim “the right material in the right quantity in the right place.” To achieve this, CFRPs are used as structural components of the 2017 R8 to reduce vehicle mass.

Force = mass x acceleration. Reducing the mass of the vehicle has several advantages. Less force, and therefore less fuel is required to achieve the same acceleration. Conversely, the same force produces higher acceleration.

## Carbon fiber reinforced polymer (CFRP)

CFRP is a composite material. It is a combination of two or more components: a reinforcing fiber and a matrix which bonds the fibers together. The combination forms a component of very high strength and rigidity.

The task of the fiber is to transfer load and absorb elongation. They also define the rigidity, strength and thermal expansion of the fiber composite. Fibers are, in principle, only able to absorb tensile forces but not compressive forces. If the fiber composite needs to be rigid in more than one direction, it is usually woven or layered at different angles.

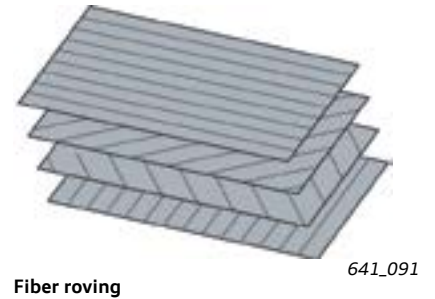
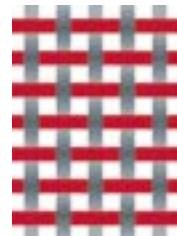
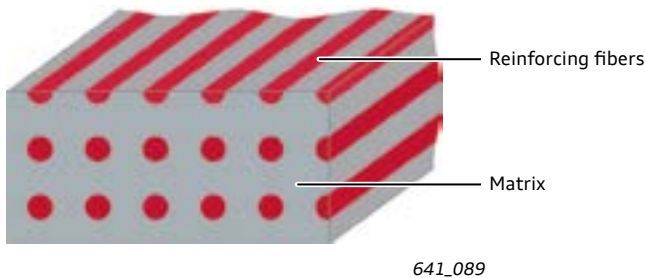

Resin is the matrix of the CFRP composite. The matrix bonds and protects the fibers and prevents them from buckling.

The rigidity, strength and thermal expansion of the fiber composite are, likewise, partly defined by the matrix.

## Advantages of CFRP

The main advantage of CFRP is the saving of weight. CFRP also offers advantages such as low thermal expansion, high corrosion resistance, good aging properties / fatigue strength, design freedom and good absorption properties (crash behavior).

The following comparison shows how much component weight can be saved while retaining full functionality by using different materials.

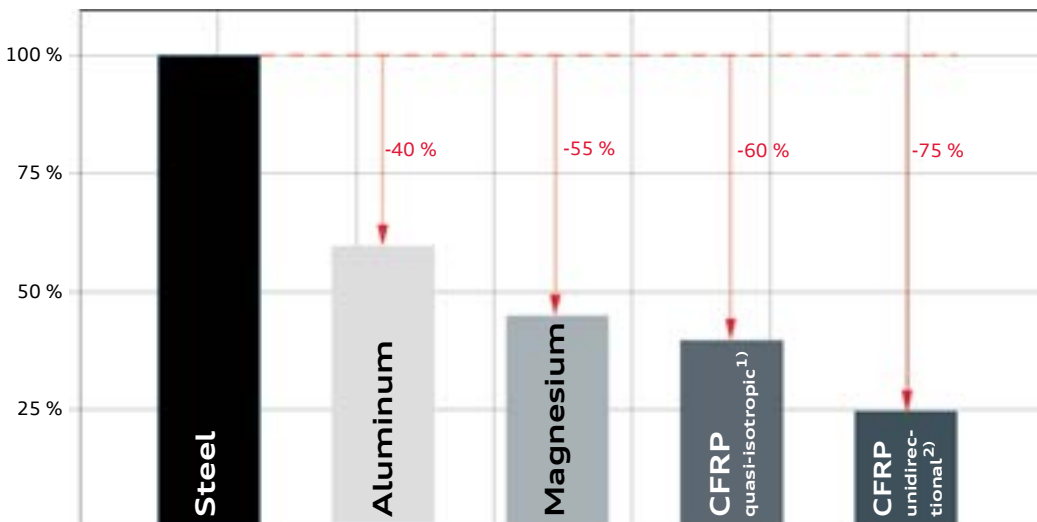

<sup>1)</sup> CFRP quasi-isotropic – the properties of the material are virtually the same in all directions.

<sup>2)</sup> CFRP unidirectional – in this connection, the fibers are oriented in one direction only.

641\_092



## Resin Transfer Molding – RTM

The CFRP parts for the Audi R8 are manufactured at Audi using the Resin Transfer Molding method. The basic steps of this RTM process are described below.



641\_093

A parting agent is applied to both sides of the mold to make removing the finished component easier.



641\_094

Multiple tailored layers of the textile structures are stacked on top of each other inside the mold.



641\_095

The mold is then closed.



641\_098

After setting, the mold is opened and the component removed.



641\_097

The resin sets within 5 to 10 min at a temperature of between 176 -248 °F (80 - 120 °C)

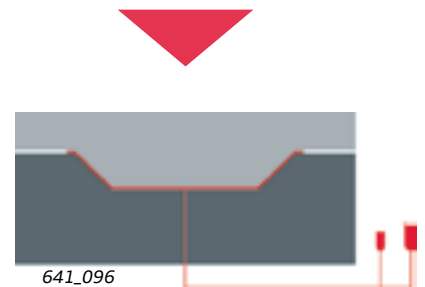

641\_096

Epoxy resin and hardener are injected into the component for between 10 to 60 seconds. The fibers are completely saturated with the liquid resin.

## Carbon fiber reinforced polymer at Audi

Depending on application, a distinction is made between visible CFRPs, Class-A CFRPs and structural CFRPs.

Visible CFRPs are used, for example, in the making of interior trim panels or door mirrors. The surface of the CFRP part is protected by a clear coat.

Until now, Class-A CFRPs have mainly been used for exterior attachments, such as body side sections and the convertible top box lid on the R8 Spyder.



641\_101



641\_099



641\_100

## Structural CFRPs

Structural CFRPs do not have a visual function in the automobile but are relevant to safety. Structural CFRP components are integrated in the vehicle body and replace a part of the bodyshell which would otherwise be made from aluminum or steel.

The structural CFC must, therefore, be capable of withstanding and absorbing high loads during vehicle operation or in an accident situation.

Structural CFRPs have to meet exacting quality requirements. The center tunnel, the upper and outer 'B' pillars and the rear bulkhead of the R8 are all manufactured from structural CFRPs.



641\_102

## Non Destructive Inspection (NDI)

After an accident, it may not be possible to visually detect potential damage within the CFRP structure. CFRP components can be dramatically impaired by minor damage. Delamination (layer separation) can occur due to an impact which will impair strength, rigidity, flexural stability and dent resistance of the laminate.

Components can be non-destructively inspected using an ultrasound testing device. Ultrasonic pulses which have a very short duration (1 - 10 microseconds) are directed through the component being tested. These sound waves are reflected by the wall of the component under inspection and return to the testing device. Special software computes the depth at which the sound was reflected (rear wall or defect) on the basis of the time elapsed between transmission and reception of the signal. This information is then displayed on a monitor using different colors.

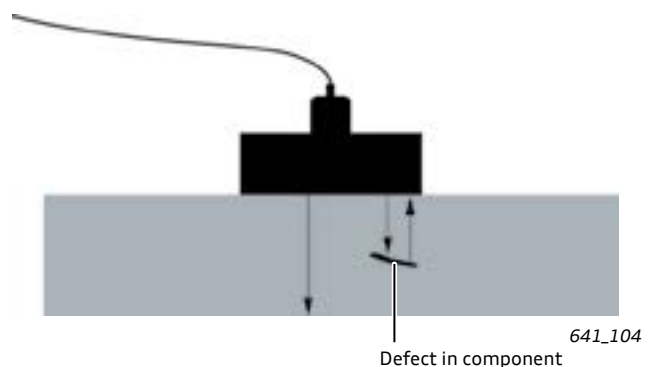
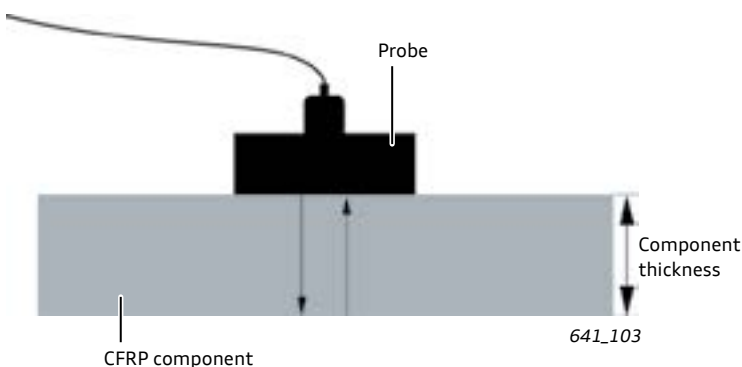

## Evaluation

The color coding in the evaluation shows the defect or damage to the component. If no defect is detected, a monochrome image will be displayed.

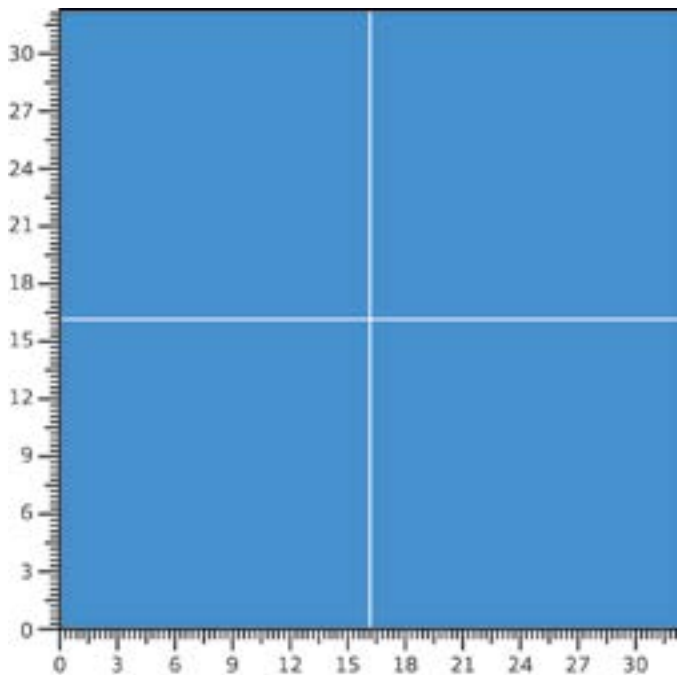

Defect-free region

641\_105

The positions in which a defect is found are indicated in color.

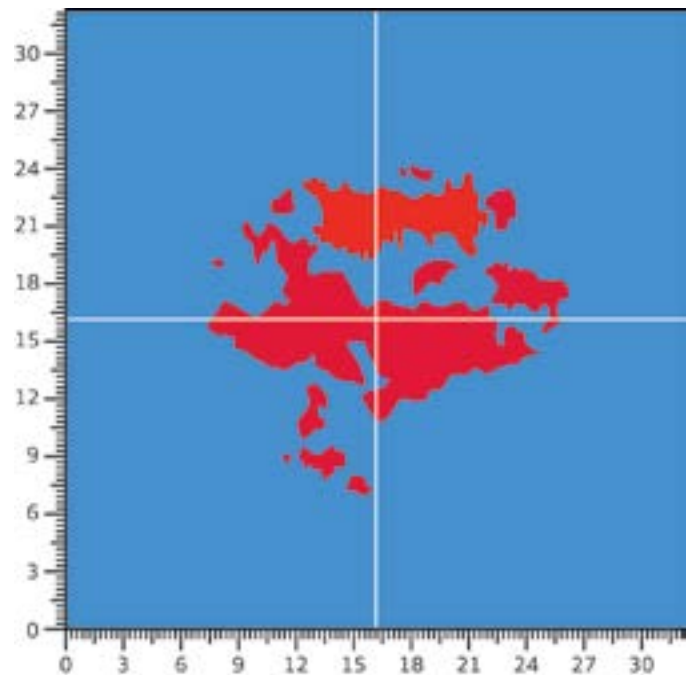

Region with defective CFRP

641\_106



### Reference

For further information about the non destructive inspection of CFRP components, refer to the current service literature in ElsaPro and ServiceNet.

## Important service information

- › Do not drill, saw, sand and perform other machining operations on CFRP components.
- › CFRPs are electrically conductive. However, it is not permissible to make electrical connections to ground through CFRPs.
- › Avoid all contact with CFRP components while carrying out work on electrical wiring (danger of short circuit).
- › Avoid hard contact with CFRP parts when repairing vehicles, for example, when removing or installing units (danger of non-visible irreparable damage to the CFRP structure).
- › Only manufacturer-approved materials, for example, primers, adhesives, rivets, may be used when performing work on the body.
- › Work on the body may only be performed using methods approved by the manufacturer.
- › Work on the body may only be performed using tools approved by the manufacturer.

## Aerodynamics

Sports cars are built to achieve one thing above all else: driving performance. A key requirement for this is the aerodynamic design – in addition to high engine output low weight, a rigid chassis and a balanced weight distribution.

An important factor to consider with regard to aerodynamics is the strong correlation between downforce and drag because the higher the downforce of a vehicle, the higher its drag coefficient that is, it takes more propulsive force to generate the energy needed to produce drive.



Audi R8 V10 with extended rear spoiler

641\_107

Compared to other supercars, the Audi R8 V10 has a very low drag coefficient: 0.34 with the rear spoiler retracted, 0.35 with the rear spoiler extended and 0.36 in the R8 V10 plus version with fixed rear spoiler.

To improve downforce at higher speeds, the rear spoiler of the R8 V10 automatically extends electrically when the vehicle exceeds a speed of about 75 mph (120 km/h). To produce more downforce, the Audi R8 V10 plus has a fixed wing made of CFRP.



Audi R8 V10 plus with fixed rear spoiler

641\_108

## Drag reduction panels

The drag reduction panels at the front and rear of the underbody and at the center tunnel ensure that the surface of the underbody is smooth.

NACA ducts<sup>1)</sup> in the underbody trims allow additional air to be channeled around the fuel tank and into the engine bay without causing a significant increase in drag.

A long, rising diffuser in the underbody exerts downforce on the rear axle at higher speeds.

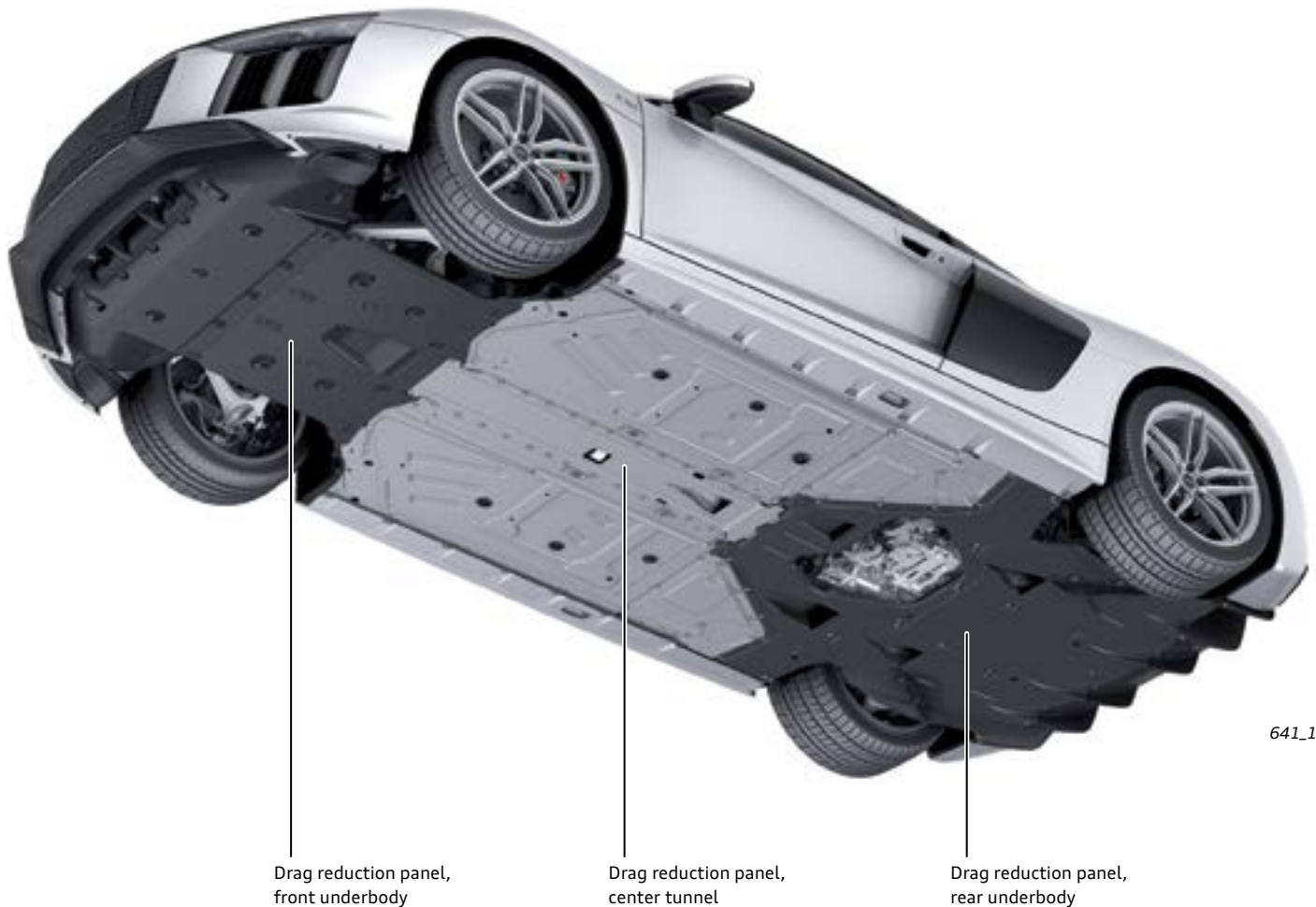

### Note

To achieve highest levels of driving performance and driving safety and to ensure that the suspension components, drive units and brakes are properly cooled, all underbody panels and wheel arch linings, front and rear spoiler elements and air ducts must be installed correctly.

<sup>1)</sup> NACA: National Advisory Committee for Aeronautics (precursor to NASA). An NACA duct is an air intake integrated in the outer skin of a vehicle.

## Seating systems

2 different seat versions are available for the new Audi R8 – the R8 sports seat and the R8 bucket seat.

As an option, both versions can be ordered with seat heaters.

### R8 sports seat

The sports seat is only available in one version in the North American Market.

- › Fully electric sports seat with pneumatic bolster adjustment in the backrest and on the seat base.

Depending on seat version, new features for the Audi R8 are an integrated head restraint, electrical seat depth adjustment and pneumatic adjustments.

Driver and Passenger Backrest Adjustment Motors V45, V46

Manual fore and aft adjustment



641\_019

## Fully electric sports seat

- > Electric length adjustment.
- > Electric height adjustment.
- > Electric backrest angle adjustment.
- > Pneumatic 4-way lumbar support.
- > Pneumatic seat base bolster adjustment.
- > Pneumatic backrest bolster adjustment.
- > Fold-down backrest.
- > "Dynamic diamond" stitching pattern. (Optional)



Fully electric sports seat, version 2

641\_021

## R8 bucket seat

The R8 bucket seat is based on a carbon seat shell. It also folds down, but the backrest angle is not adjustable. The R8 bucket seat has manually adjustable fore and aft movement as well as electric height adjustment.



641\_022

# Occupant protection

## Overview

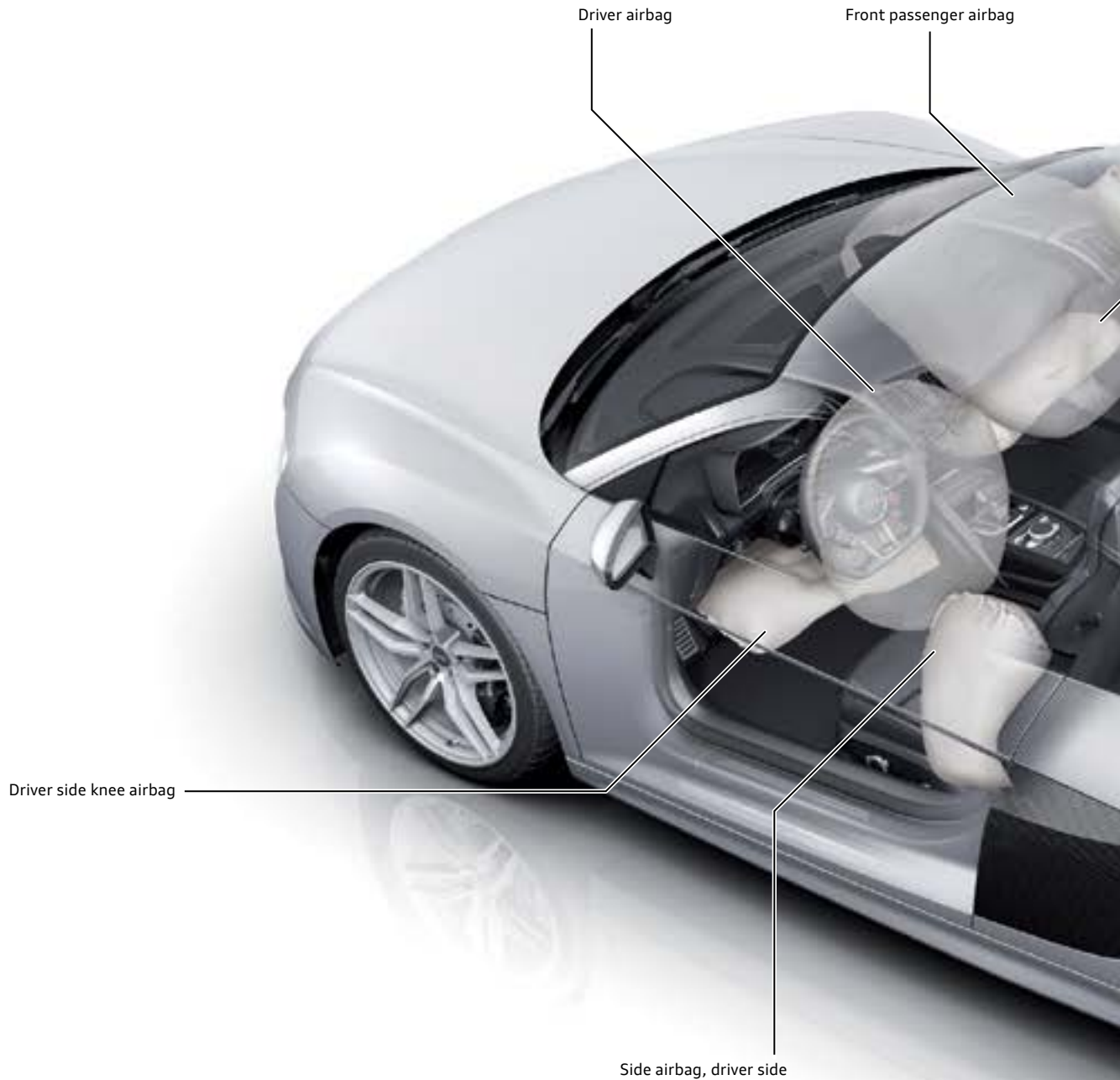

## Components

- > Airbag Control Module.
- > Driver airbag.
- > 2-stage front passenger airbag.
- > Front side airbags.
- > Head airbags.
- > Knee airbags.
- > Front airbag crash sensors.
- > Crash sensors for side impact detection in the doors.
- > Crash sensors for side impact detection in the 'B' pillars.
- > Front inertia-reel safety belts with pyrotechnic belt tensioners with adaptive belt force limiters.
- > Safety belt warning for all seats.
- > Safety occupancy sensor in front passenger seat
- > Front passenger airbag disabling switch.
- > Front passenger airbag OFF and ON warning lamp.
- > Driver and front passenger seat position sensors.
- > Battery interrupt igniter.





# System overview

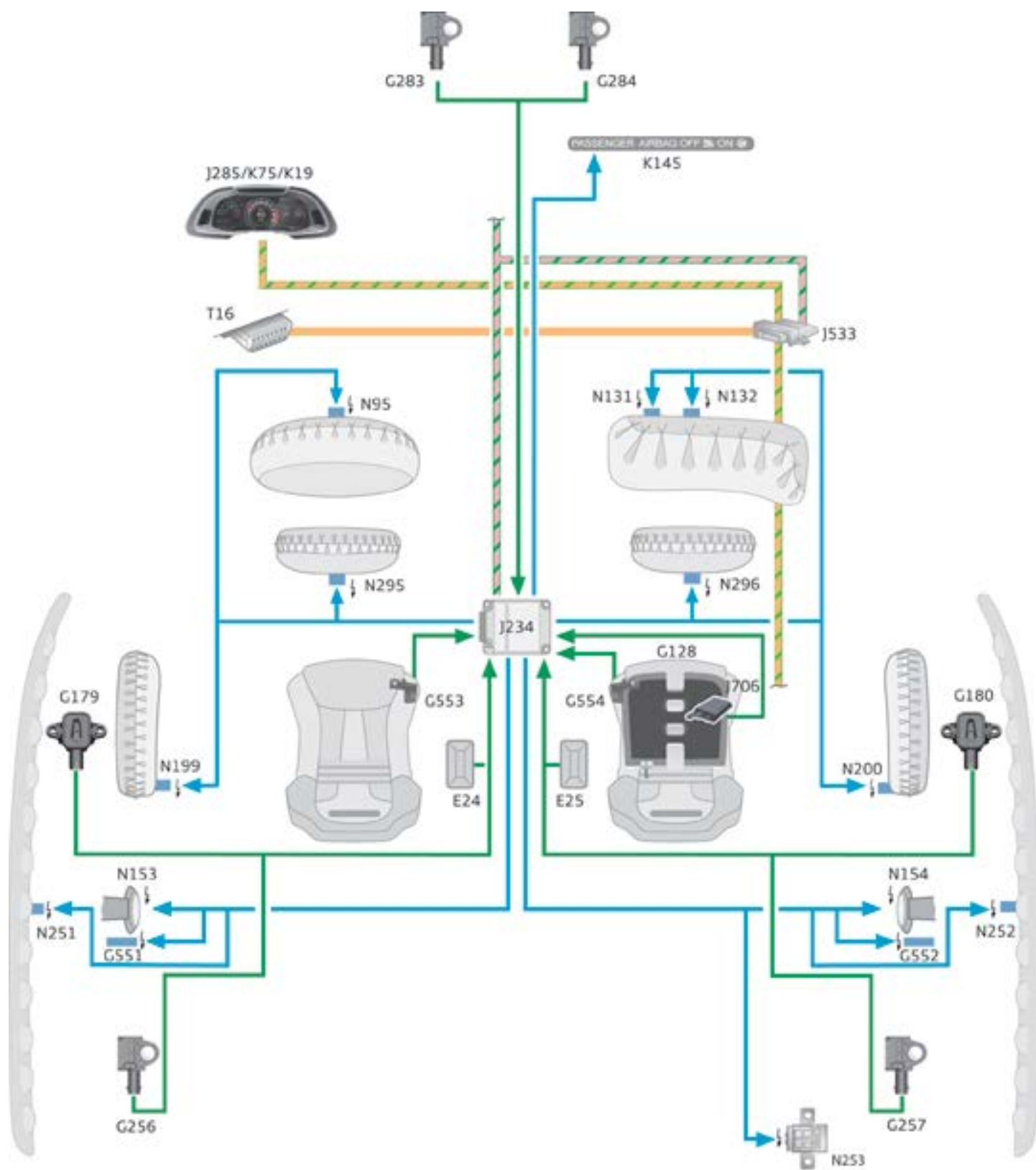

641\_023 (rev)

## Key to illustration on page 22:

**E24** Driver Seat Belt Switch

**E25** Front Passenger Seat Belt Switch

**G128** Front Passenger Occupant Detection Sensor

**G179** Driver Thorax Airbag Crash Sensor

**G180** Front Passenger Thorax Airbag Crash Sensor

**G256** Driver Side Rear Thorax Airbag Crash Sensor

**G257** Passenger Side Rear Thorax Airbag Crash Sensor

**G283** Driver Front Airbag Crash Sensor

**G284** Passenger Side Front Airbag Crash Sensor

**G551** Driver Belt Force Limiter

**G552** Front Passenger Belt Force Limiter

**G553** Driver Seat Position Sensor

**G554** Front Passenger Seat Position Sensor

**J234** Airbag Control Module

**J285** Instrument Cluster Control Module

**J533** Data Bus On Board Diagnostic Interface (Gateway)

**J706** Passenger Occupant Detection System Control Module

**K19** Seat Belt Indicator Lamp

**K75** Airbag Indicator Lamp

**K145** Front Passenger Airbag -Disabled- Indicator Lamp

**N95** Driver Airbag Igniter

**N131** Front Passenger Airbag Igniter 1

**N132** Front Passenger Airbag Igniter 2

**N153** Driver Seat Belt Tensioner Igniter 1

**N154** Front Passenger Seat Belt Tensioner Igniter 1

**N199** Driver Thorax Airbag Igniter

**N200** Front Passenger Thorax Airbag Igniter

**N251** Driver Head Curtain Airbag Igniter

**N252** Front Passenger Head Curtain Airbag Igniter

**N253** Battery Interrupt Igniter

**N295** Driver Knee Airbag Igniter

**N296** Front Passenger Knee Airbag Igniter

**T16** Data Link Connector

## Diagram color identification:

 Powertrain CAN

 Convenience CAN

 Diagnostics CAN

 FlexRay

 Input signal

 Output signal

# Engines

## Specifications

### Torque-power curve of 5.2l V10 engine (engine code CSPA)

- Power output in hp (kW)
- Torque in lb ft (Nm)



641\_123

The engine number can be found on the right-hand side of the engine block, below the cylinder head on the poly-V belt side.

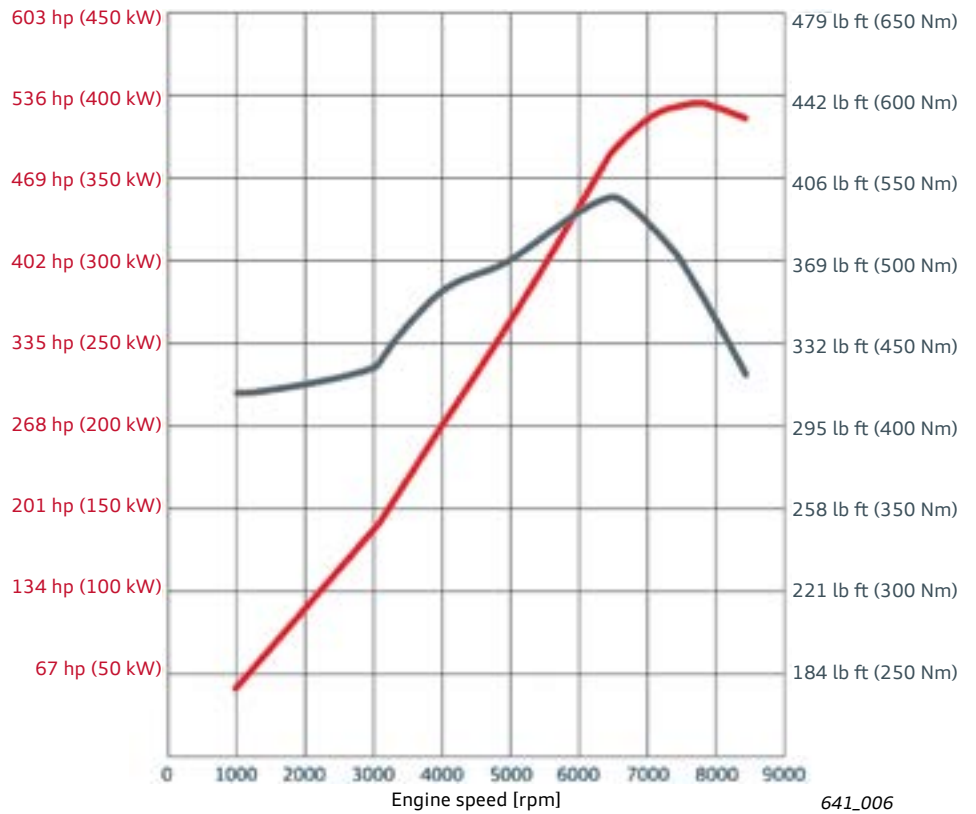

641\_006

Features	Specifications
Engine code	CSPA
Type	10-cylinder V-engine with 90° V angle and dry sump lubrication
Displacement	317.6 cu in (5204 cm <sup>3</sup> )
Stroke	3.65 in (92.8 mm)
Bore	3.33 in (84.5 mm)
Number of valves per cylinder	4
Firing order	1-6-5-10-2-7-3-8-4-9
Compression ratio	12.5:1
Power output at rpm	540 hp (397 kW) @ 7800 rpm
Torque at rpm	398 lb ft (540 Nm) @ 6500
Fuel type	95 RON
Engine management system	Bosch MED 17.1.1 dual control modules (master/slave concept)
Oxygen sensor/knock control	Adaptive O <sub>2</sub> , adaptive knock control
Mixture formation	Combined (dual) direct (FSI) and multipoint (MPI) injection
Emission standard	LEV II - ULEV / Tier 2 - BIN 5

## Torque-power curve of 5.2l V10 plus engine (engine code CSPB)

- Power output in hp (kW)
- Torque in lb ft (Nm)



641\_039

The engine number can be found on the right-hand side of the engine block, below the cylinder head on the poly-V belt side.

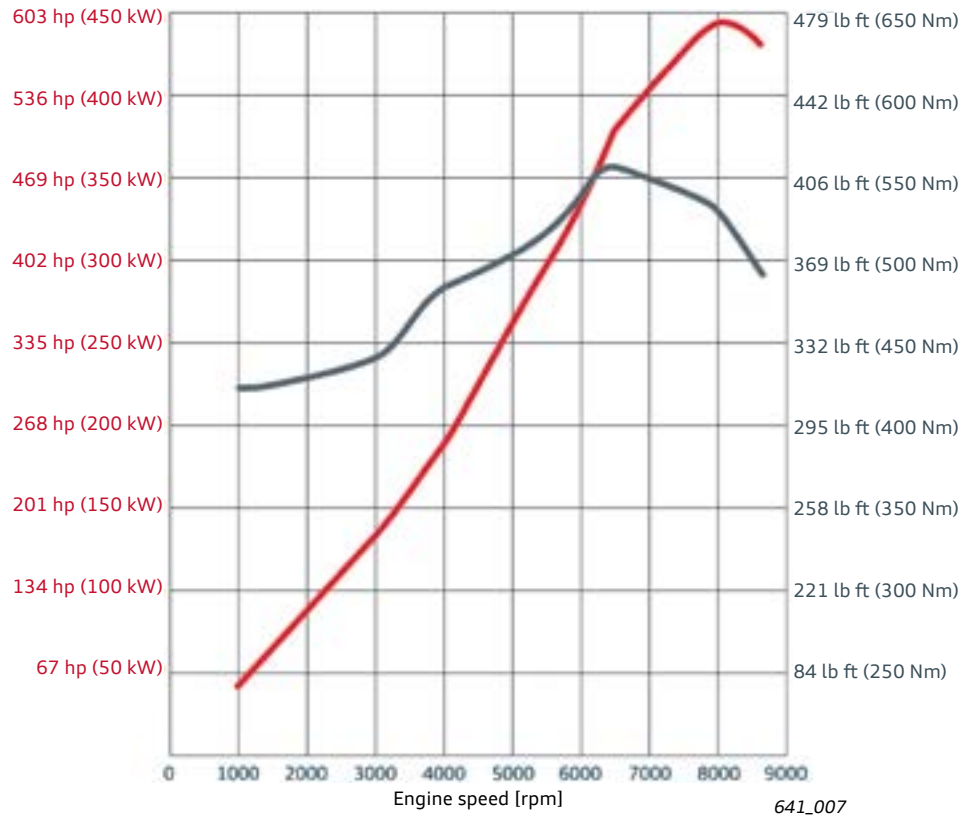

Features	Specifications
Engine code	CSPB
Type	10-cylinder V-engine with 90° V angle and dry sump lubrication
Displacement	317.6 cu in (5204 cm <sup>3</sup> )
Stroke	3.65 in (92.8 mm)
Bore	3.33 in (84.5 mm)
Number of valves per cylinder	4
Firing order	1-6-5-10-2-7-3-8-4-9
Compression ratio	12.5:1
Power output at rpm	610 hp (449 kW) @ 8250
Torque at rpm	413 lb ft (560 Nm) @ 6500
Fuel type	95 RON
Engine management system	Bosch MED 17.1.1 dual control modules (master/slave concept)
Oxygen sensor/knock control	Adaptive O <sub>2</sub> , adaptive knock control
Mixture formation	Combined (dual) direct (FSI) and multipoint (MPI) injection
Emission standard	LEV II - ULEV / Tier 2 - BIN 5

# Modifications to the 5.2l V10 engines

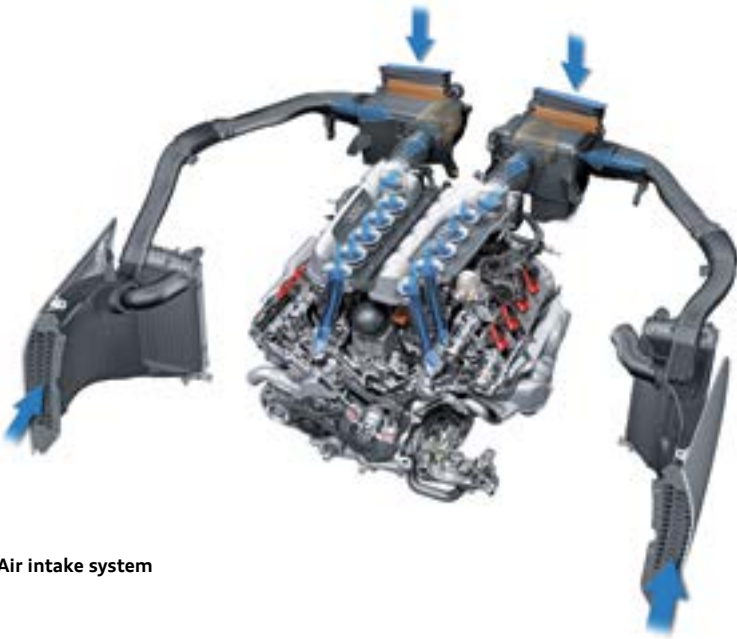

Air intake system

641\_012

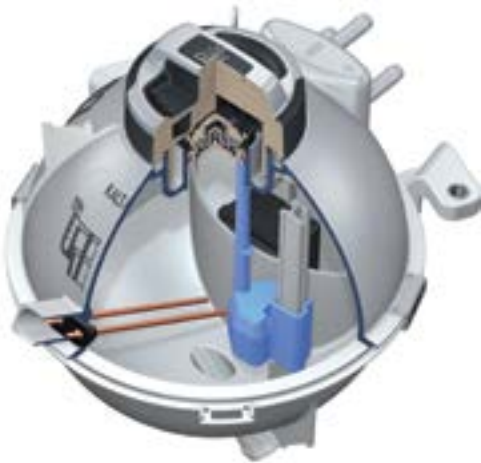

641\_124

Coolant expansion tank



Oil tank with dry sump lubrication

641\_008



641\_009



641\_085

Dual fuel injection system



641\_042

Cylinder-on-demand



Modified cooling circuit

641\_040

## Oil circuit

The 5.2l V10 engine are, like its predecessor, equipped with a dry sump lubrication system. The very low installation position of the engine brings the center of mass of the vehicle closer to the road.

Lubrication of the engine must be maintained at all times regardless of driving style. This is ensured by the oil pump module and external oil reservoir.

The crankcase chambers are separated from one another by an oil deflector. The geometry of the blade reduces gas circulation and churning losses within the chambers.

## Overview

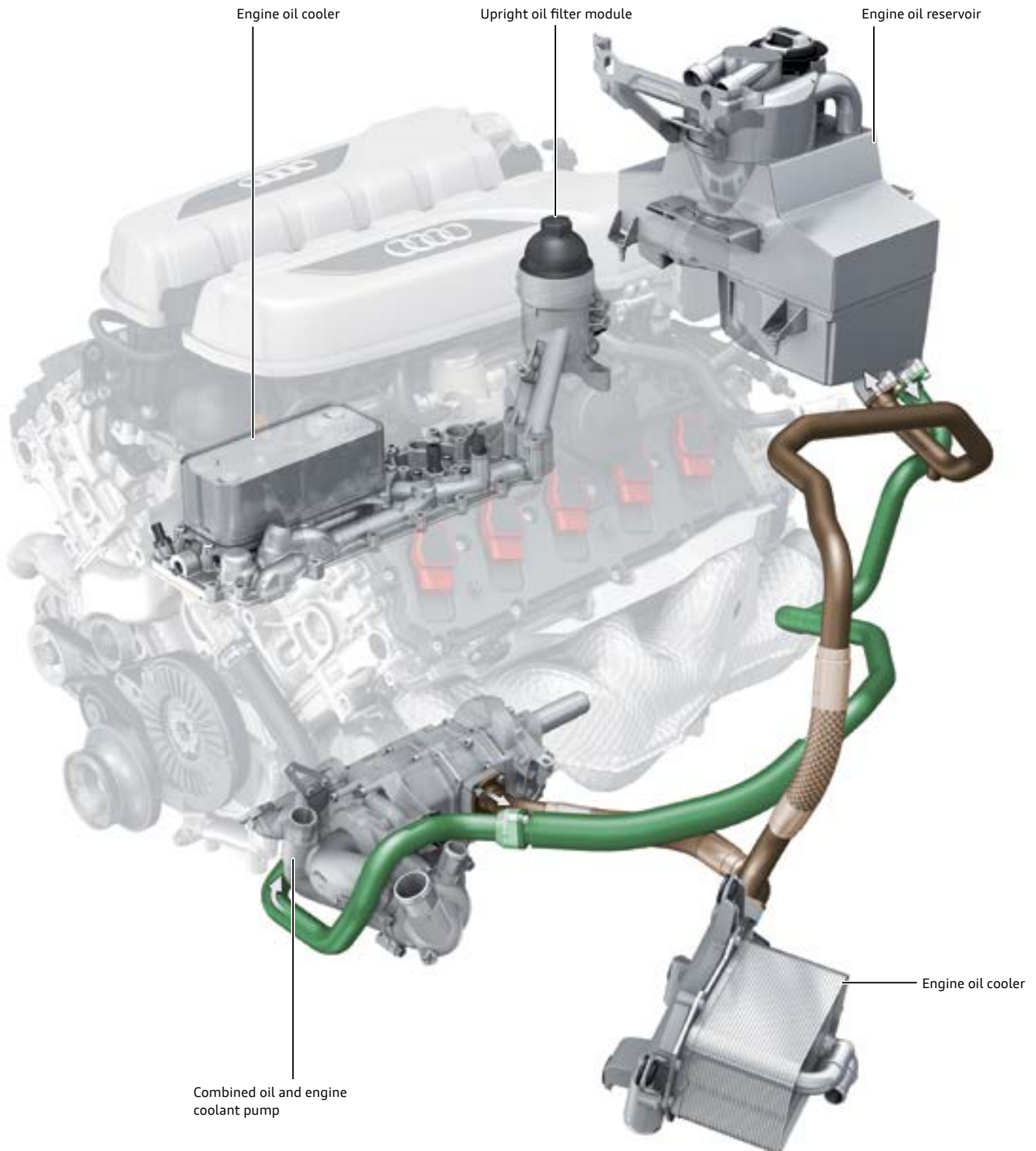



## Oil delivery

The pump provides continuous extraction of engine oil from the crankcase, timing chain case and the cylinder heads through two suction stages.

It pumps the oil through the two oil-coolant heat exchangers into the oil tank.

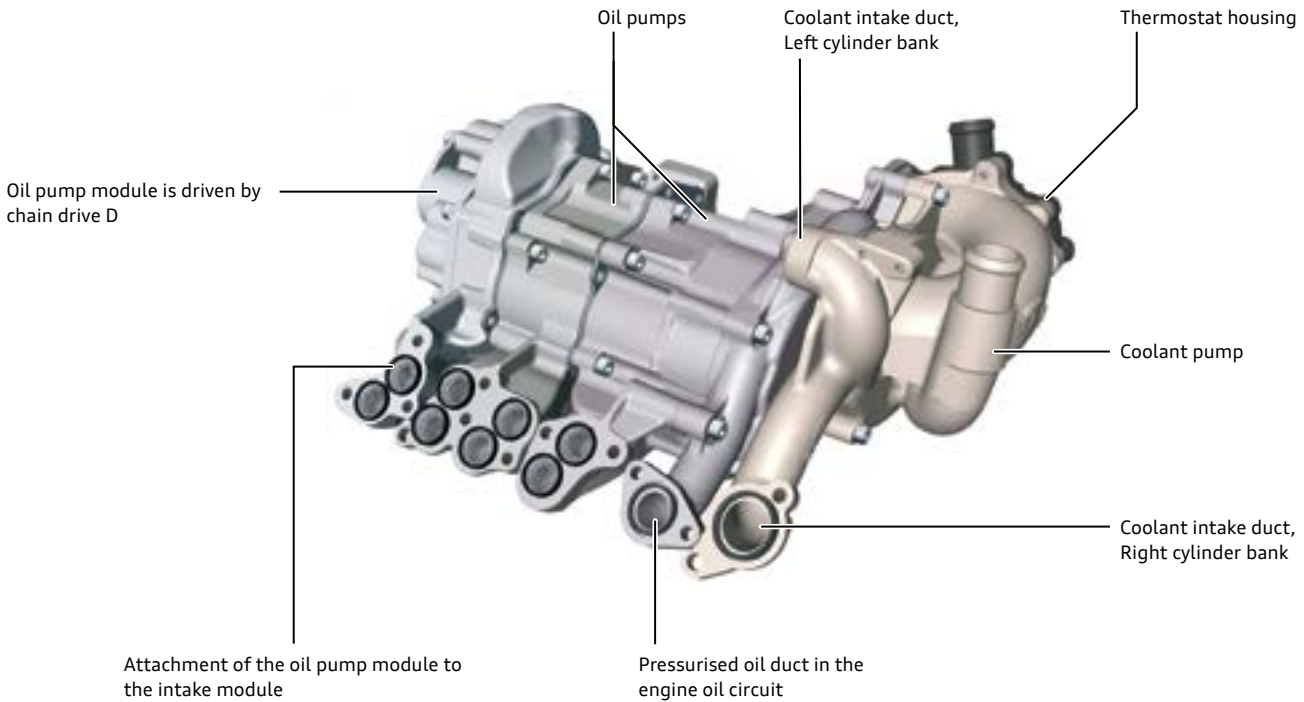

## Oil tank with dry sump lubrication

The blow-by gases are separated from the oil by a cyclone built into the top section of the oil reservoir. The blow-by gas flows out of the oil reservoir and into the intake manifold via the fine oil separator downstream of the throttle flaps. The separated oil collects in the bottom of the oil reservoir. From here, the oil is drawn in on the suction side of the pump pressure stage and flows through the main oil filter to the bearings.

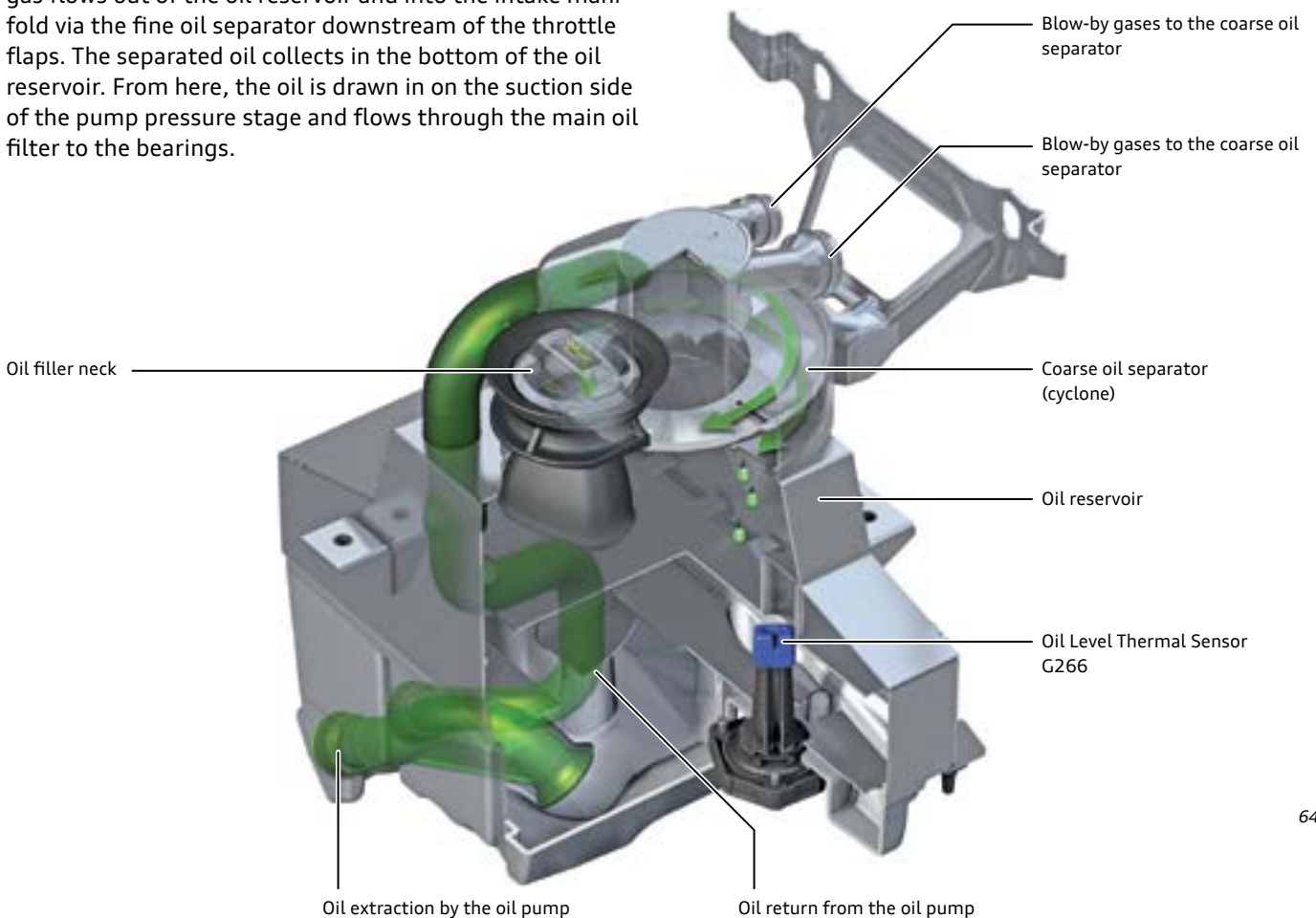

## Crankcase ventilation

Positive crankcase ventilation is provided by the cylinder head covers in which a large settling chamber acts as a gravity oil separator. A 3-stage register cyclone with a bypass valve is used as a fine oil separator.

Connection below intake manifold downstream of throttle valve

Connection in the inner V for positive crankcase ventilation

Pressure control valve for positive crankcase ventilation

Connection upstream of throttle valve for ventilation of the crankcase with non-return valve

Oil reservoir ventilation and inflow to coarse oil separator

Fine oil separator (mini-cyclone separator)

Coarse oil separator in the cylinder head cover

Inflow of blow-by gases from the oil reservoir

641\_163

## Evaporative emission system

The 5.2l V10 engines feature cylinder-on-demand (COD) which requires the use of two Evap Canister Purge Regulator Valves. In COD mode, the active cylinder bank must vent the carbon canister into the intake manifold while the valve for the inactive cylinder bank closes.

Evap Canister Purge Regulator Valve 2 N115

Carbon canister connection

Evap Canister Purge Regulator Valve 1 N80

Connection 1 to intake manifold for cylinder bank 1

Connection 2 to intake manifold for cylinder bank 2

641\_164

## Air supply

The engine is supplied with air via the side blades. In high load demand situations, active bypass flaps in the air filter boxes are opened. If the active bypass flaps are open, the engine draws in air through the air grid below the rear window (in front of the rear spoiler).

While driving, the side-blades direct the airflow through additional outlets into the engine bay in order to prevent heat build-up from occurring here. At the same time, the air flows through both auxiliary radiators for ATF cooling and oil cooling.

## Overview

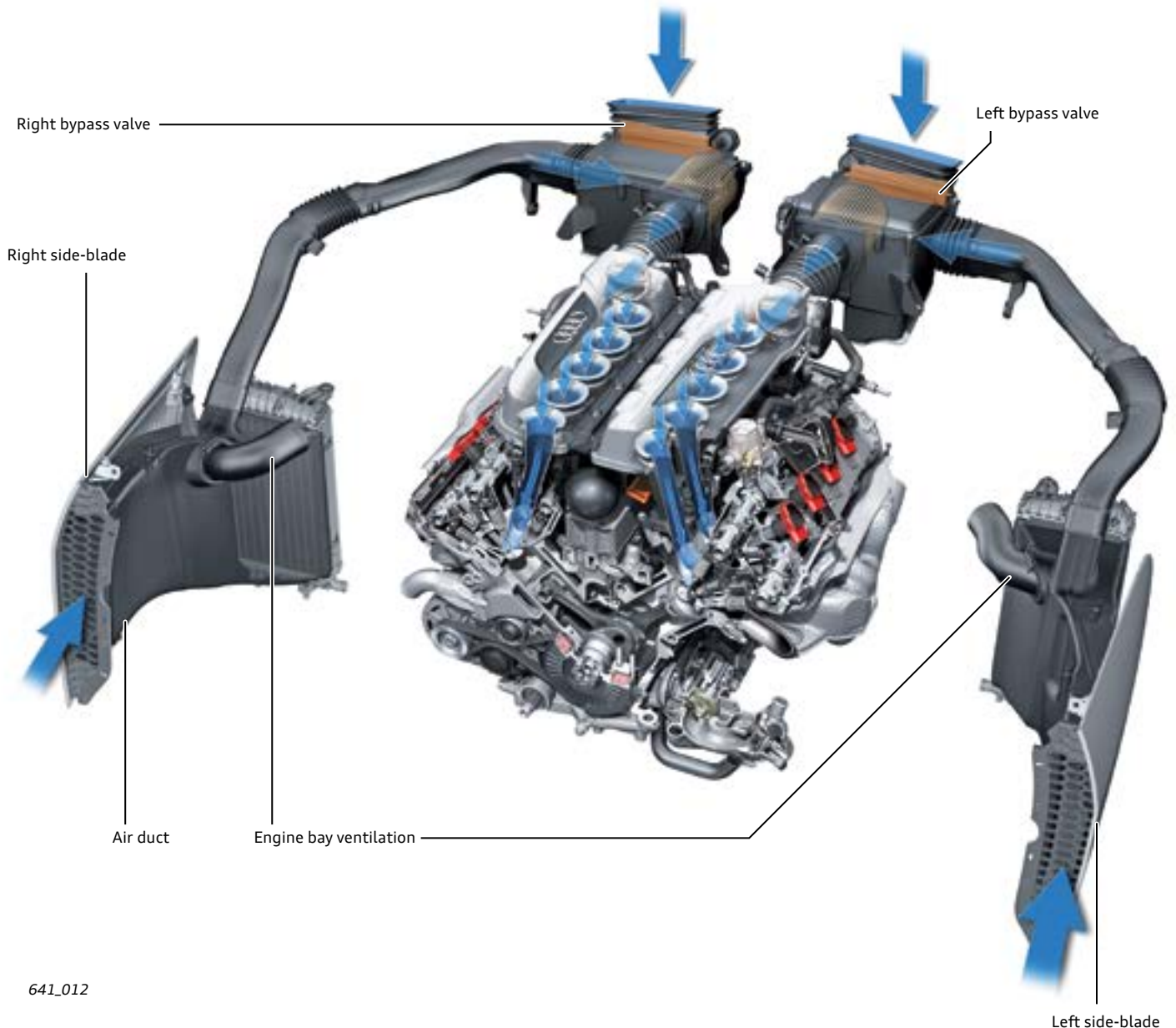

## Noise reduction

To reduce noise from the engine, the bypass valves in the air filter boxes are closed when the engine is started, at idle and at drive-away. The bypass valves open when the mass air flow rate exceeds 140 kg/h and close when it drops below 120 kg/h.

To utilize the full power of the engine, the bypass valves must be opened if the characteristic in the engine map is exceeded.

The bypass valves are actuated by vacuum motors.

## Dual fuel injection system

For the first time, the Audi R8 uses a fuel injection system that combines the advantages of the direct and indirect injection systems. In the classic indirect injection system, the air-fuel mixture is formed upstream of the intake valve. This results in better mixture formation, lower particulate matter emissions and less fuel condensation in the cylinder.

In the direct injection system, the thin fuel film on the inner walls of the cylinders provides better cooling and a reduced knock tendency.

Other advantages are the very short injection time and the high efficiency of the system. Depending on engine load, the ECM selects the appropriate system – from indirect injection only to a situation-based combination of both types of injection. The result is a better power yield, better fuel economy and lower emissions.

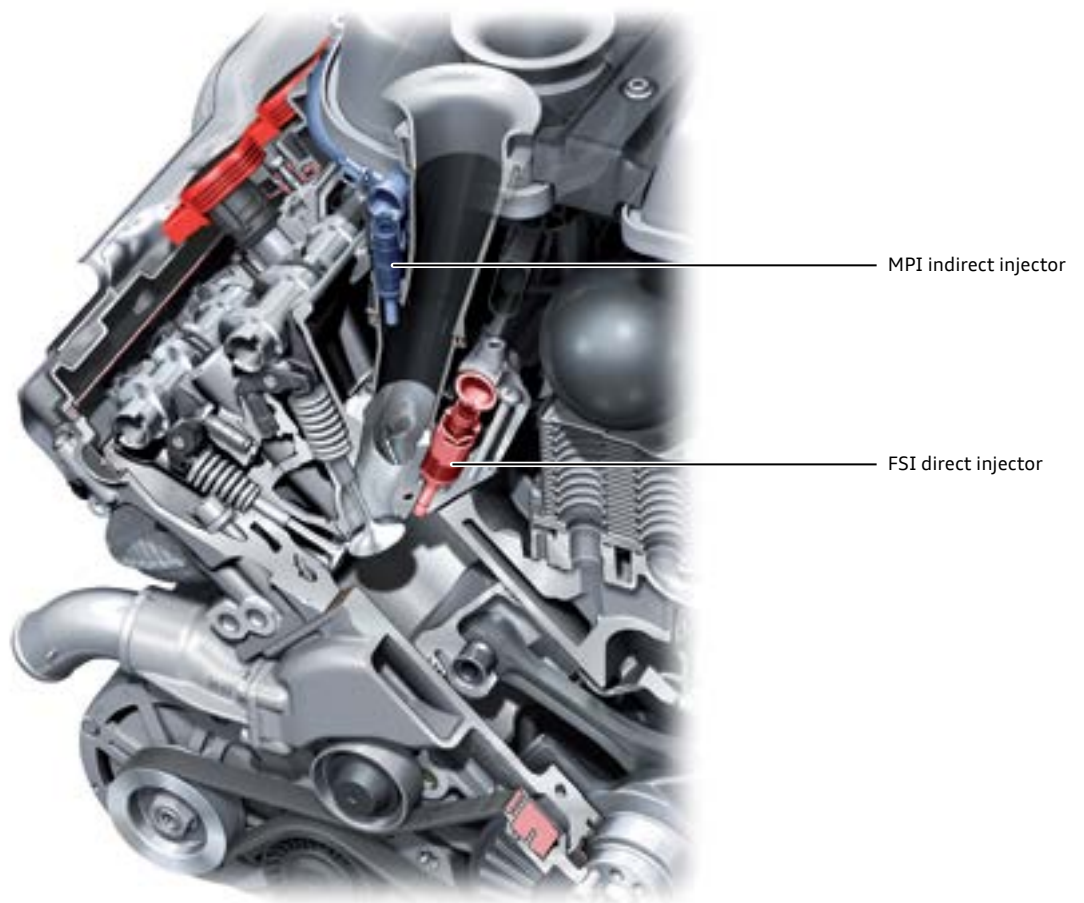

641\_024

## Operating characteristics of the combined fuel injection system

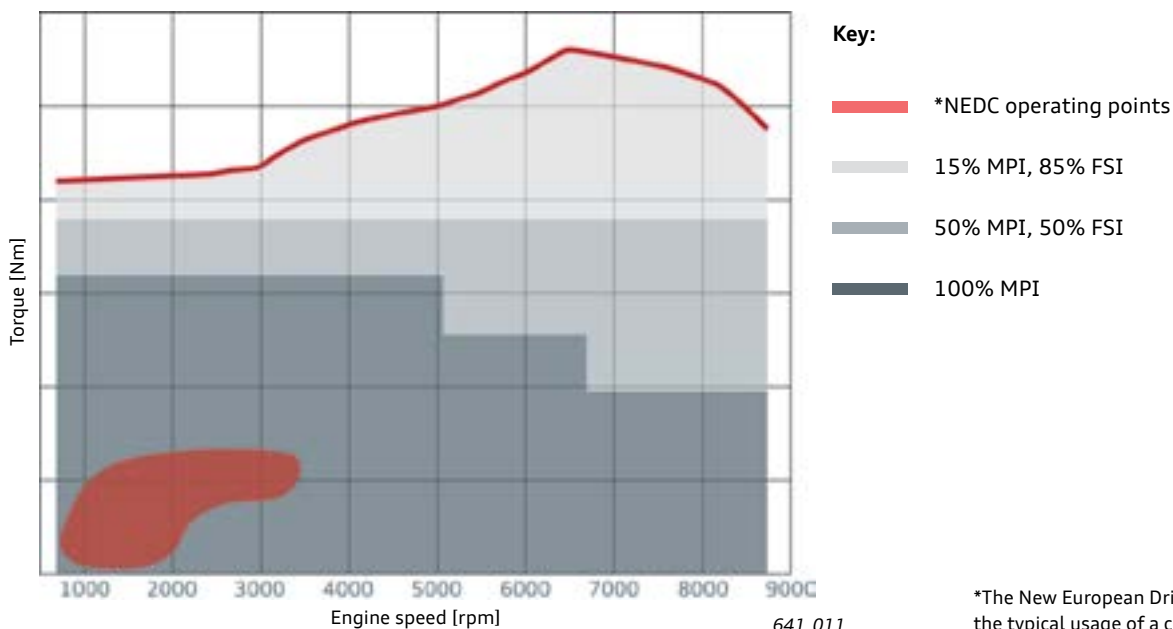

641\_011

\*The New European Driving Cycle (NEDC) represents the typical usage of a car driven in Europe.

# Fuel supply

## System overview

The MPI system has its own pressure sensor - Low Fuel Pressure Sensor G410. Pressure is supplied on demand by Transfer Fuel Pump G6 in the fuel tank. It is activated by Fuel Pump Control Module J538 via the ECM.

The high-pressure fuel pumps are driven by a 2-lobe cam on the intake camshafts. Depending on engine speed and requirements (map), they generate system pressures ranging from about 1450 psi (100 bar) at 350 rpm to 2900 psi (200 bar) at about 3000 rpm.

Both cylinder banks are supplied with fuel in such a way that they operate separately from one another.

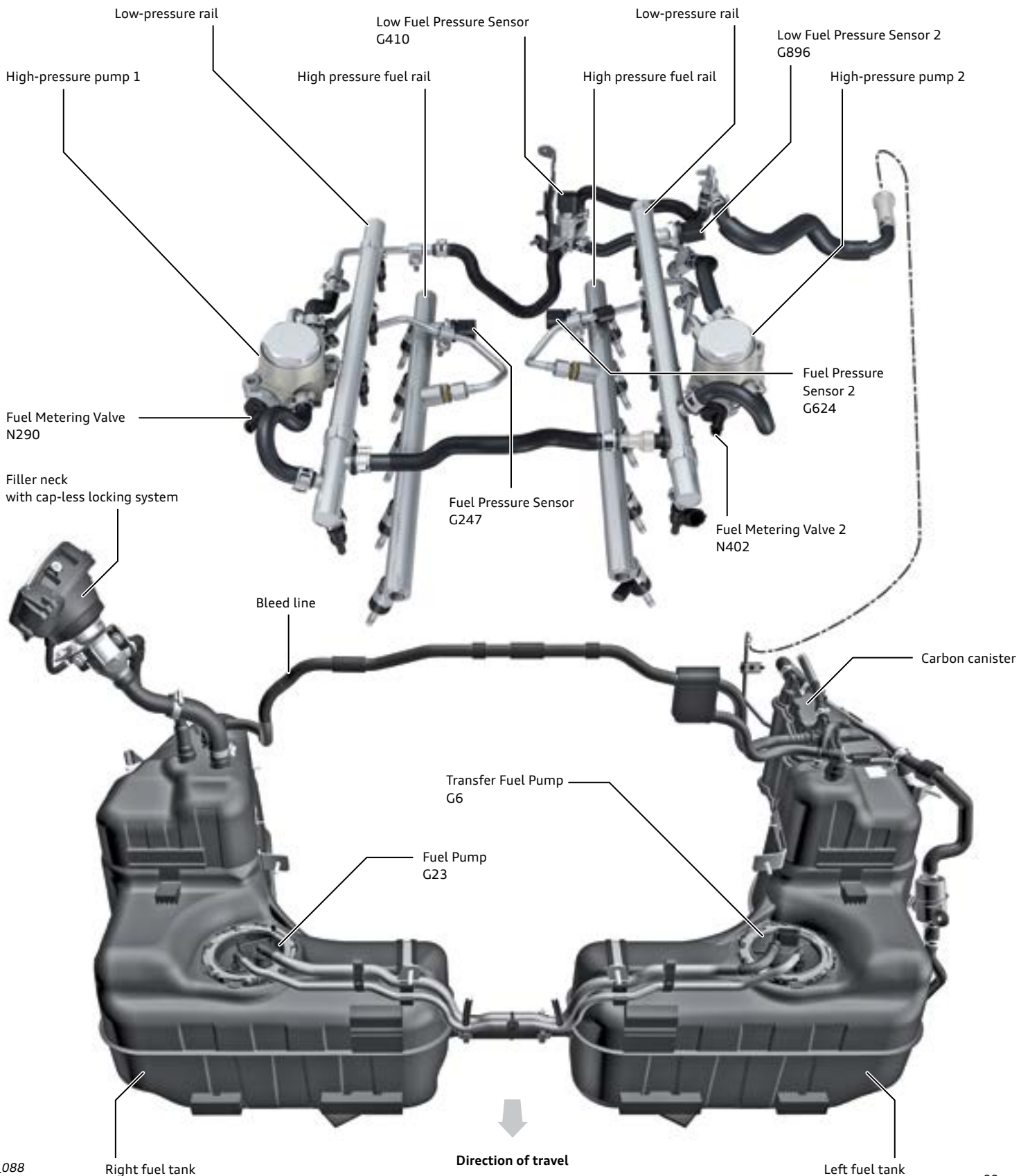

## Cylinder-on-demand

When cylinder-on-demand is active, the injection and ignition systems for one cylinder bank are shut down by the ECM. The driver is not informed when cylinder-on-demand is active.

### Enabling conditions

- › Engine at operating temperature (coolant temperature higher than 113 °F [45 °C]).
- › 3rd gear or higher is selected.
- › Vehicle travelling faster than 16.8 mph (27 km/h).
- › Engine speed between 1000 and 4500 rpm.
- › Low to medium engine load with maximum cylinder charging at about 65% (depending on engine speed).
- › Maximum torque: approximately 133 - 146 lb ft (180 - 200 Nm).
- › The mean temperature of the catalytic converter is the control variable for enabling cylinder bank shut-off. The calculated temperature of the converter must be greater than 662 °F (350 °C).



## Exceptions to cylinder-on-demand operation

There is no possibility of cylinder shutdown at high engine load on roads with a gentle gradient or when coasting on roads with a steep gradient.

In periods of a defined steering angle, a defined accelerator position or when the brake is applied, cylinder shut down is suppressed for a short time, for example, in a roundabout.

## Algorithm for cylinder bank changeover

The modeled catalytic converter mean temperature is the control variable for the running time in cylinder-on-demand mode.

If temperature in the catalytic converter drops below the minimum temperature of about 662 °F (350 °C) while a cylinder bank is shut off, both cylinder banks (full engine operation) will be activated for about two seconds. Then, when the temperature of the catalytic converter on the other cylinder bank exceeds 662 °F (350 °C), this bank switches to cylinder-on-demand mode.

To avoid cross flow between the cylinder banks (via the blow-by line), the throttle valves of both cylinder banks are set at the same angle.

To avoid frequent changeovers, cylinder shutdown is only enabled if the physical enabling conditions have been met and there is enough time for cylinders to shut down.

In the Audi R8 V10 (6 plus overdrive transmission), the longer gear ratios lead to a shift in the load points (lower engine speed – higher load). Accordingly, the active range of the cylinder on demand function in the Audi R8 V10 is smaller, and less noticeable.

Driving at the same speed, the Audi R8 V10 plus may utilize the active range of the cylinder-on-demand function in the **dynamic** mode of the Audi drive select handling system while the Audi R8 V10 does not.

## Exhaust temperature sensor

The V10 and the V10 plus each have a single temperature sensor per cylinder bank configured as a SENT sensor<sup>1)</sup>. The electronics are integrated in the sensor connector. The sensor calculates a theoretical mean temperature for cylinder-on-demand operation. It monitors the catalytic converter and protects it from overheating.

<sup>1)</sup> The SENT (Single Edge Nibble Transmission) data protocol can, in conjunction with the appropriate sensors, be used for digital data transfer instead of analog interfaces.

If the accelerator position changes repeatedly or numerous steering inputs are made, for example, in urban traffic the probability of cylinders being shut down is reduced.

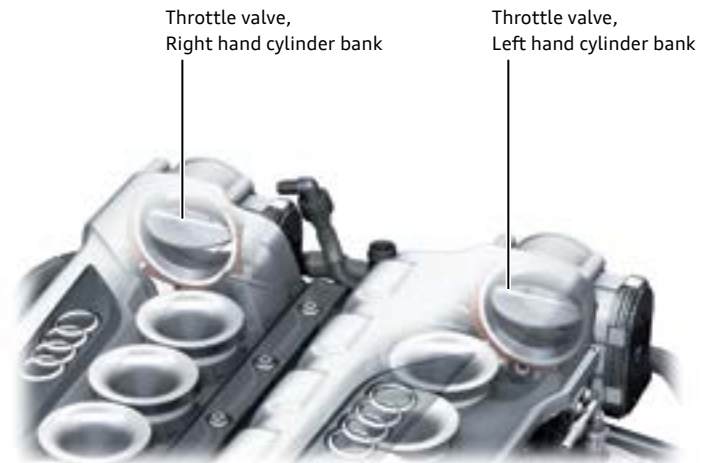

641\_045

## Driver profile

There is no driver profile adaptation during cylinder shut-off. The vehicle is reset to the initial state after every restart. Regardless of the driver's previous behavior, the vehicle is reset to the same initial state as at start-up after a maximum of 30 seconds of steady driving.

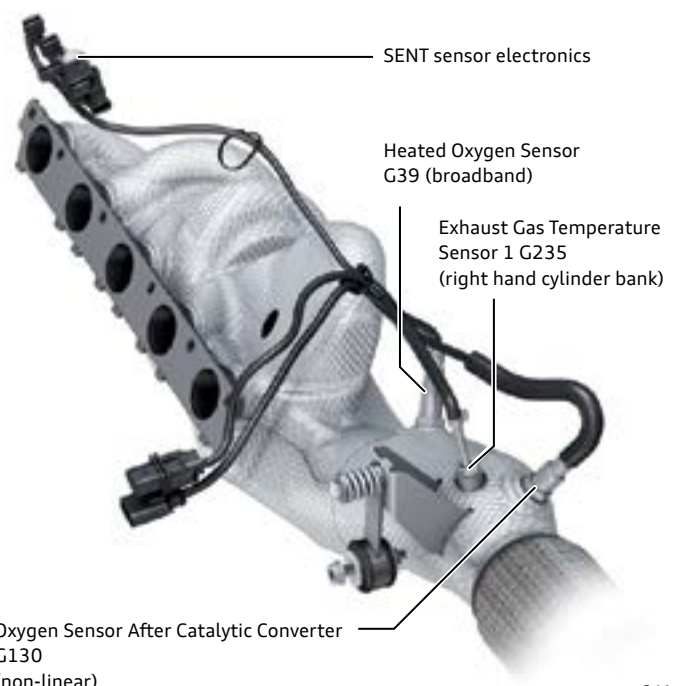

641\_086

# Cooling circuit

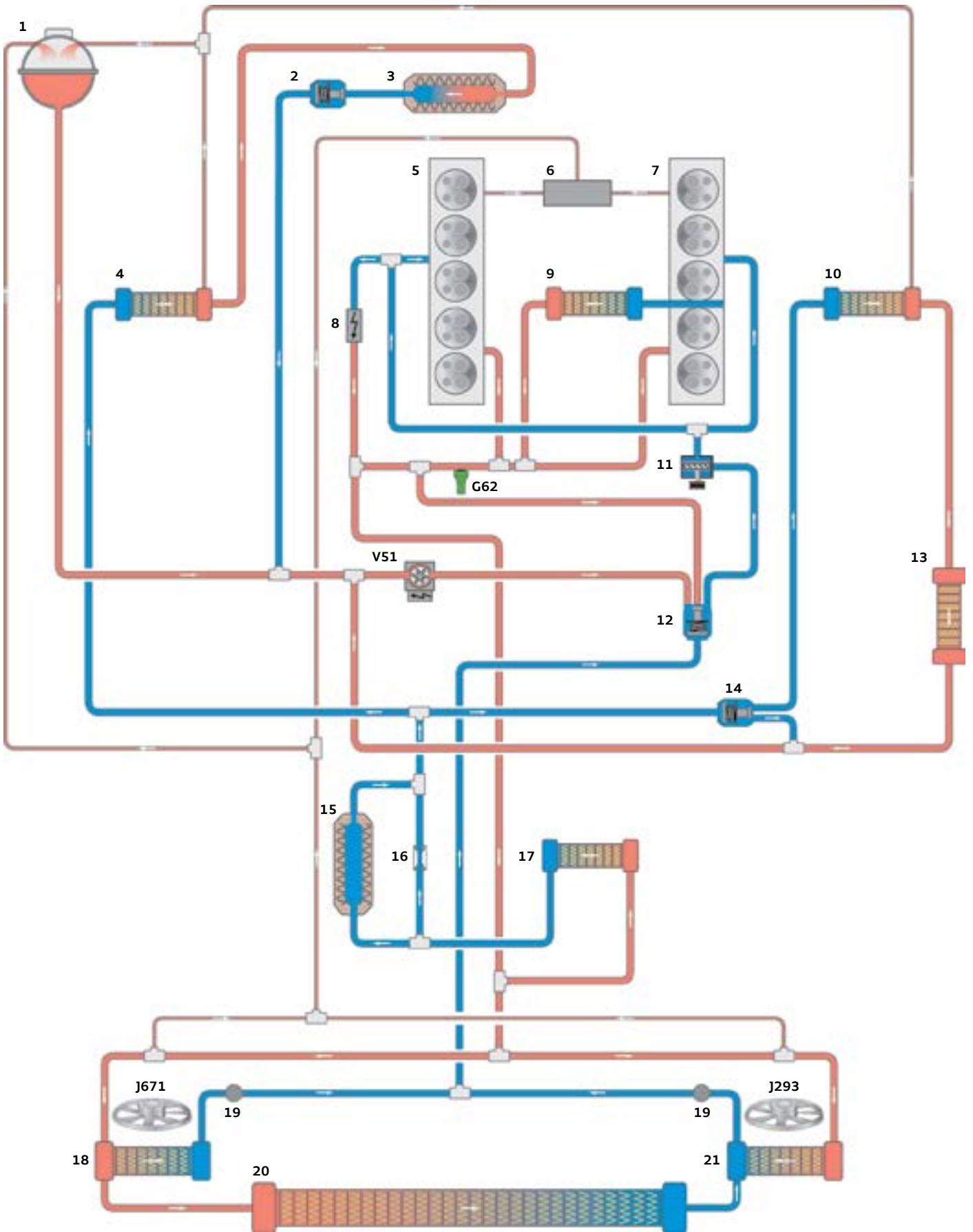



## Key to illustration on page 36

- |           |                                                                    |             |                                              |
|-----------|--------------------------------------------------------------------|-------------|----------------------------------------------|
| <b>1</b>  | Coolant expansion tank                                             | <b>14</b>   | Coolant thermostat for engine oil cooler     |
| <b>2</b>  | Coolant thermostat for ATF cooling                                 | <b>15</b>   | Front axle differential                      |
| <b>3</b>  | Transmission oil cooler (ATF heat exchanger)                       | <b>16</b>   | Flow restrictor                              |
| <b>4</b>  | Auxiliary radiator for ATF cooling (air to water)                  | <b>17</b>   | Heater heat exchanger                        |
| <b>5</b>  | Cylinder head, bank 1                                              | <b>18</b>   | Right hand auxiliary radiator (air to water) |
| <b>6</b>  | Positive crankcase ventilation                                     | <b>19</b>   | Vent screw                                   |
| <b>7</b>  | Cylinder head, bank 2                                              | <b>20</b>   | Main radiator                                |
| <b>8</b>  | Liquid-cooled alternator                                           | <b>21</b>   | Left hand auxiliary radiator (air to water)  |
| <b>9</b>  | Engine oil cooler (water to oil)                                   | <b>G62</b>  | Engine Coolant Temperature Sensor            |
| <b>10</b> | Left hand auxiliary radiator for engine oil cooling (air to water) | <b>J293</b> | Radiator Fan Control Module J293             |
| <b>11</b> | Coolant pump                                                       | <b>J671</b> | Radiator Fan Control Module 2 J671           |
| <b>12</b> | Coolant thermostat                                                 | <b>V51</b>  | After-run Coolant Pump                       |
| <b>13</b> | Engine oil cooler 2 (water to oil)                                 |             |                                              |

## Coolant expansion tank

The cooling system is filled with G13 and distilled water and has a capacity of 25.3 qt (24l). The coolant expansion tank has a float-type dipstick which allows the coolant level to be checked more easily. The dipstick must extend about 0.4 in (1 cm) (1st slot) over the edge of the coolant expansion tank when the engine is cold.

The expansion tank has a silicate filling, which does not need to be renewed. It consists of a silica gel ( $\text{SiO}_2$ ) with a grain size ranging from 0.5 – 2.0 mm. When the coolant expansion tank is replaced, the new tank is pre-filled with silicate.

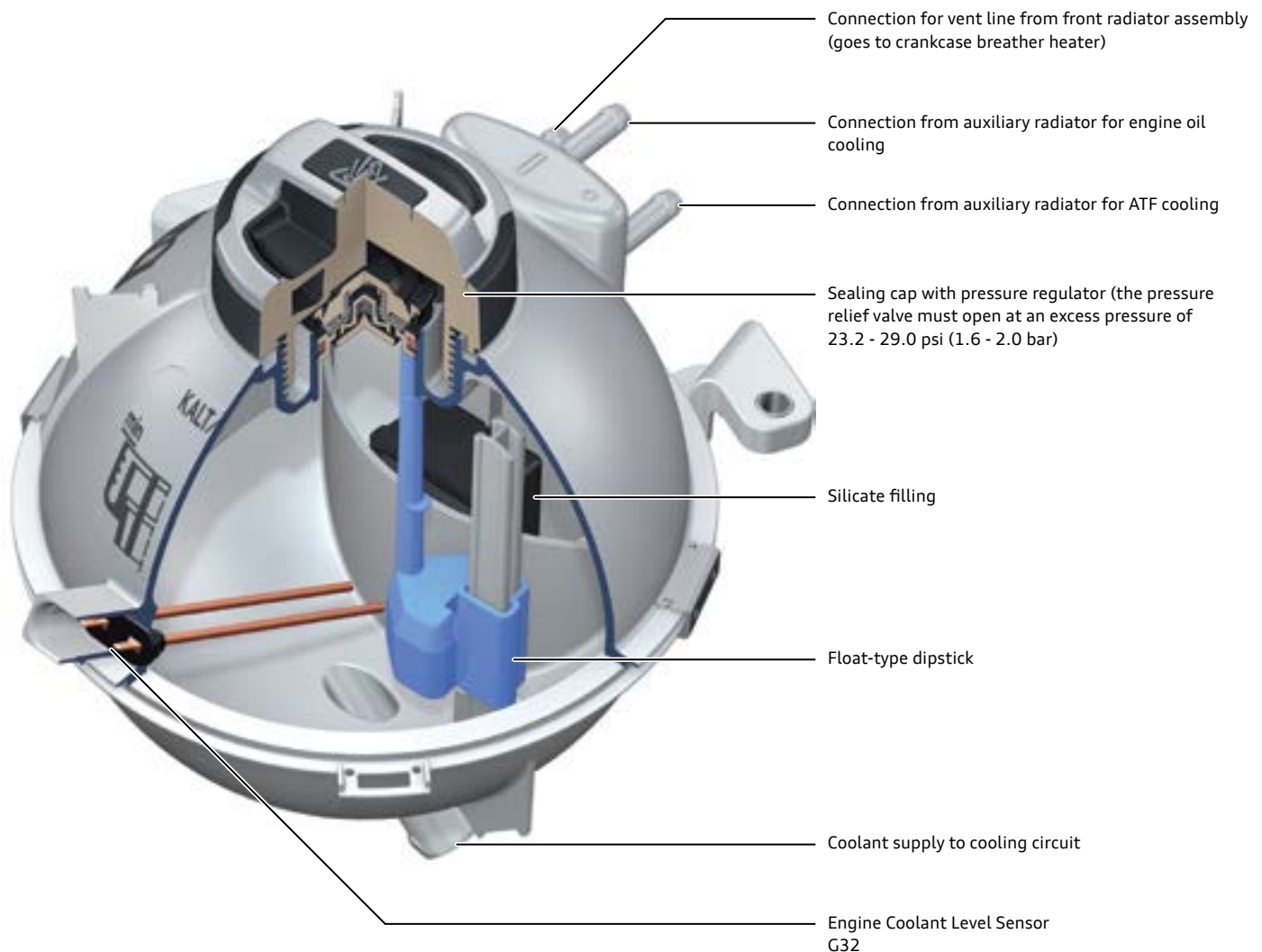

## Radiator and coolant lines

The cooling system has three radiators placed at the front end. Two radiators are located behind the large lateral air ducts, which are supplied with cooling air by two large fans.

Another radiator is located at the center at the lower edge behind the single-frame grille and is effectively supplied with cooling air by aerodynamically optimized air ducts without the use of a fan.

The high performance coolant pump is flange mounted to the engine and pumps coolant to all three radiators through 1.4 in (36 mm) aluminum pipes. The coolant flow is divided by a 'Y' connection and directed to the two outer radiators. After passing through the left hand radiator, coolant flows directly to the return line to the coolant pump.

In the right-hand radiator, the coolant is re-directed through the radiator and into the main radiator. After flowing through the auxiliary radiator, the coolant flows directly into the return line and back to the engine through a bypass in the auxiliary radiator.

The advantage of this combined series and parallel configuration of the left and right-hand sides is that it allows a uniform distribution of the coolant while maximizing the rate of flow through all three radiators. The cooling system does not feature Innovative Thermal Management.

## Overview

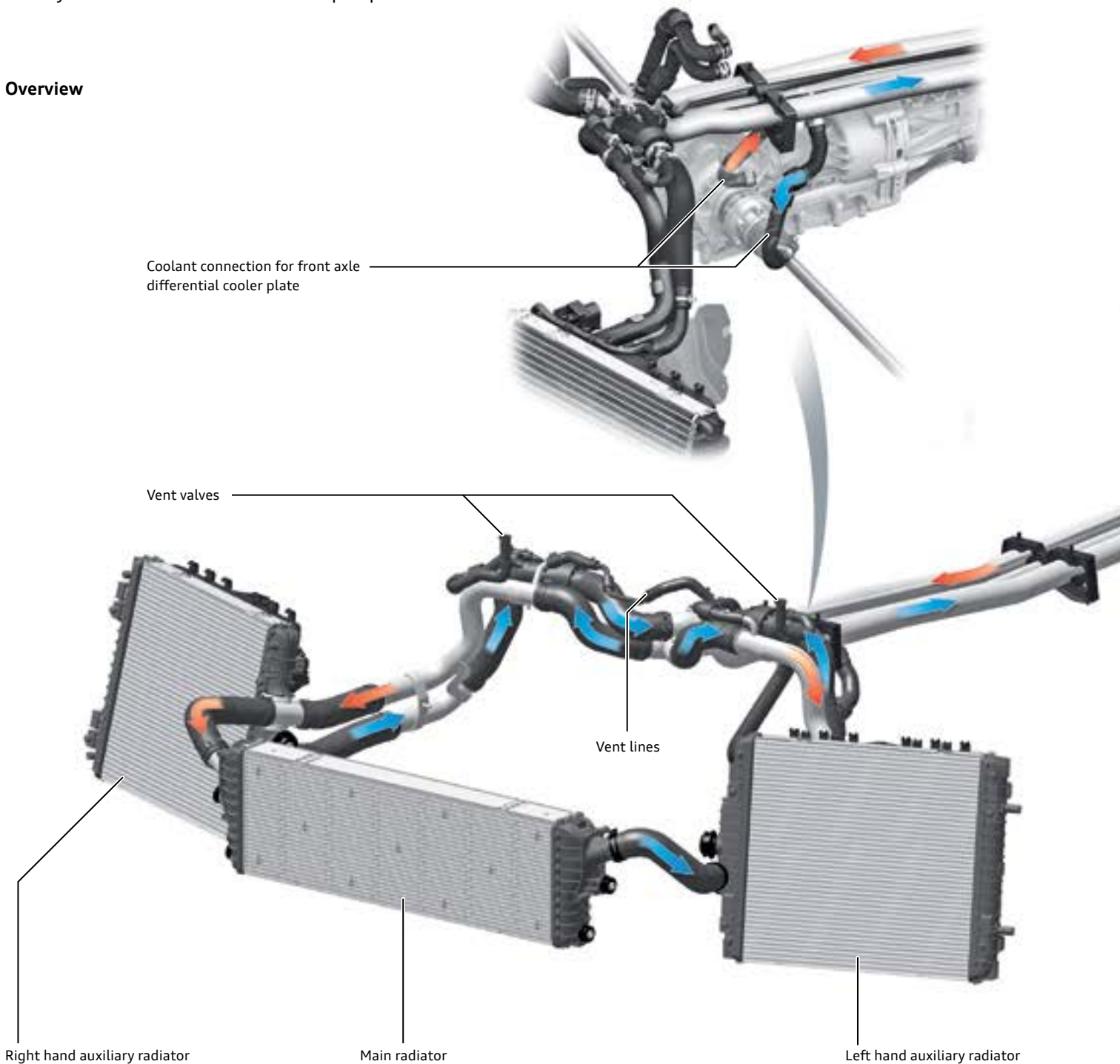

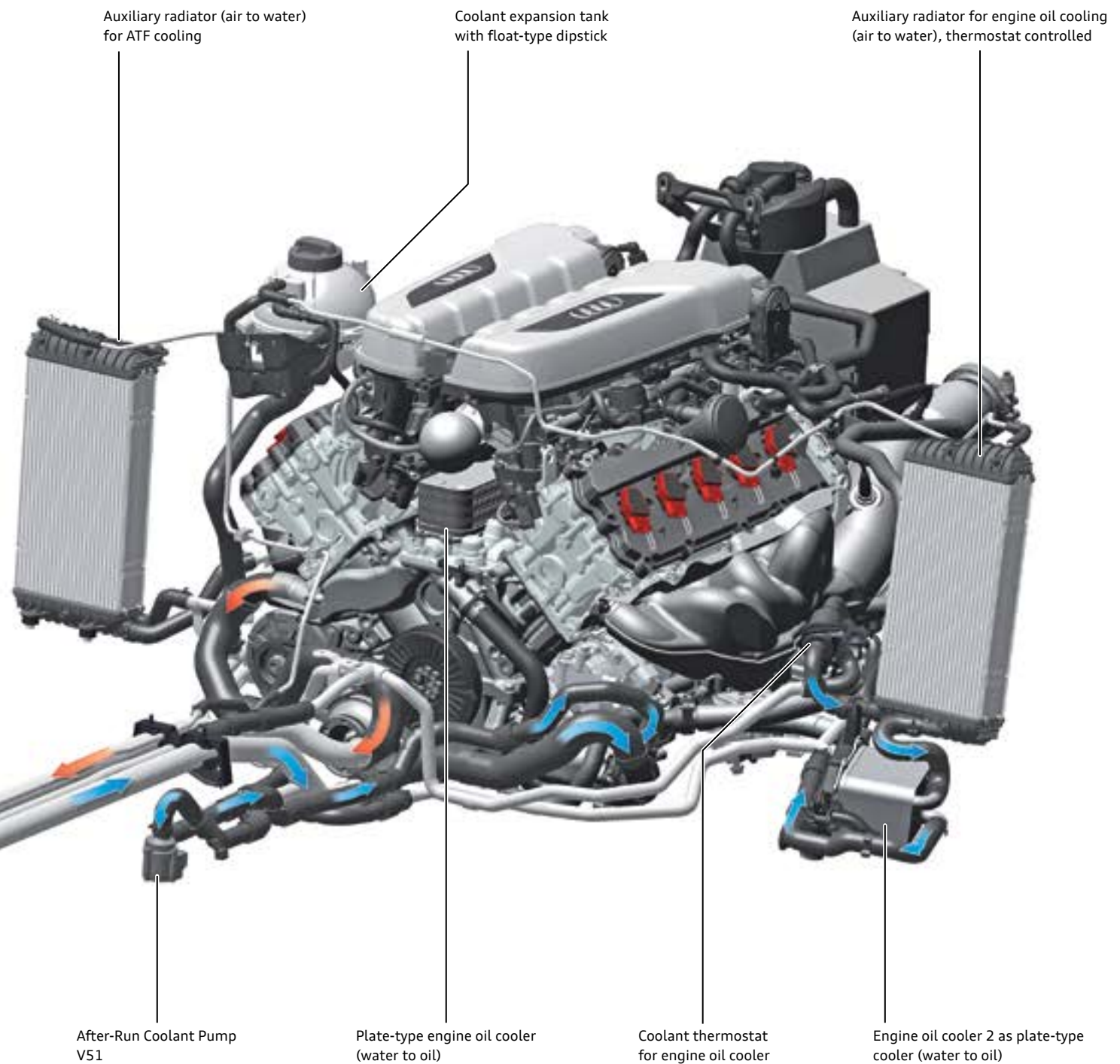

641\_036

## Secondary cooling

To provide for secondary cooling of the engine after it has been subjected to high thermal load, both fans and the separate after-run pump are activated after the engine is shut off.

Having been pre-cooled by the fan, the secondary coolant flows to the engine through the coolant lines and ensures that the high temperatures are quickly dissipated at the cylinder heads.

## Exhaust system

The auditory driving experience is essentially a combination of engine and powertrain noise, roll comfort including tire/road noise, as well as wind noise.

This noise has to be counterbalanced by the sports car sound of the engine, as characterized by the sporty mid-engine concept of the Audi R8.

The object is to accompany every movement of the accelerator and every change in engine speed and torque by sound modulation which not only matches the performance and power delivery of the engine but also accentuates the experience. All of these are key to engine sound design.

Its sound characteristic is distinguished by a powerful and restrained engine note at part throttle and by a sporty and voluminous soundscape at full throttle. During changes in engine speed and load, this sound is modulated to provide the driver with audible feedback on the performance and power delivery of the V10 engine.

SENT sensor electronics

Exhaust Gas Temperature  
Sensor 2  
G448

Heated Oxygen  
Sensor 2  
G108

Oxygen Sensor 2 After Catalytic Converter  
G131

Main catalytic converter for left hand bank,  
cylinders 6 - 10

Exhaust gas flap with vacuum  
motor, left hand side

Exhaust end piece

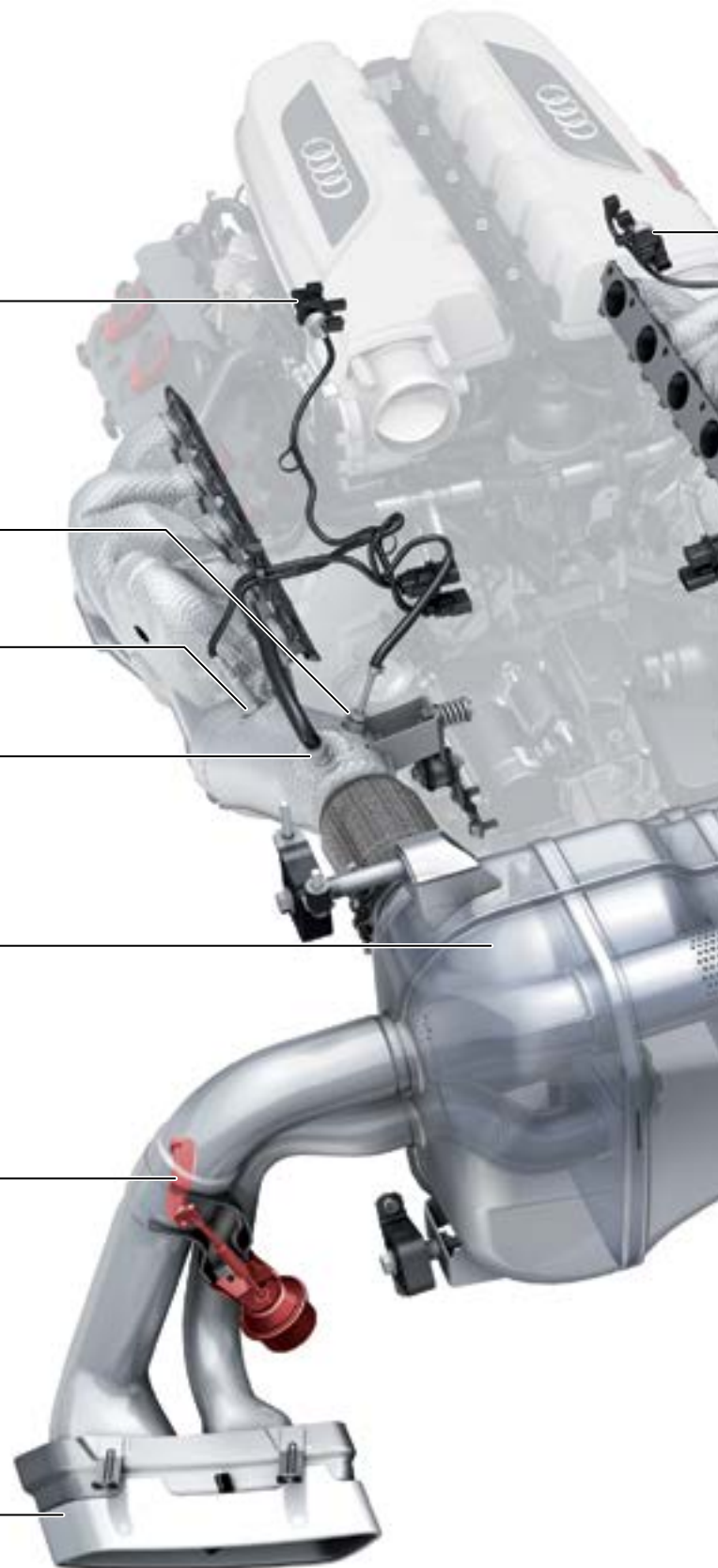

The exhaust system of the Audi R8 uses a reflection-type silencer and consists of:

- > 2 catalytic converters with heated oxygen sensors before the catalytic converter.
- > 2 temperature sensors.
- > 2 post catalytic converter oxygen sensors.
- > 2 main catalytic converters fitted in the main silencer.
- > 2 exhaust flaps.

A special feature of the inner tubes in the silencer is that the exhaust gases flow from the right-hand cylinder bank to the tailpipes on the left-hand side and emerge in reverse.

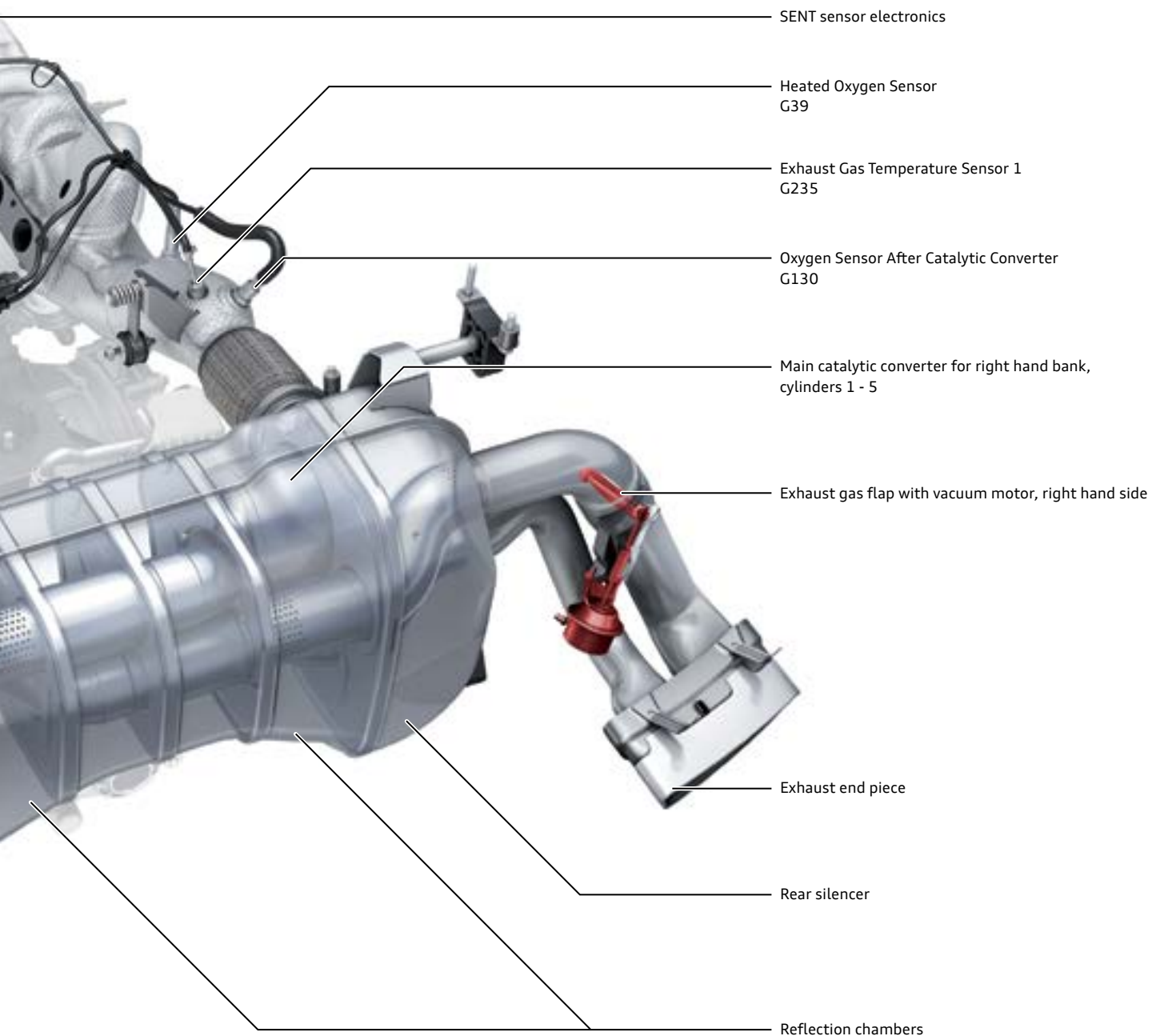

# Power transmission

## Overview

The power of the V10 engines of the R8 is transmitted to the wheels by the 7-speed DSG transmission OBZ, and a new front axle differential.

The newly developed front axle differential incorporates an electro-hydraulic multi-plate clutch which allows drive force to be variably distributed to the front axle.

When the all-wheel drive clutch is not activated, 100% of the drive force is transmitted to the rear axle. Its mechanical limited slip differential provides traction at the rear wheels.

Depending on driving situation, driver input and weather conditions, up to 406 lb ft (550 Nm) of torque can be transmitted through the pinion shaft (refer to page 59) to the front axle final drive within a fraction of a second.

This variable distribution of torque to the front axle allows driving dynamics to be controlled in a specific way. This, together with torque vectoring and other driving dynamics systems, creates a highly emotional driving experience.

Automatic Transmission Control  
Module 2  
J1006



Transmission Control Module  
J217  
(integral component of the Mechatronic module)

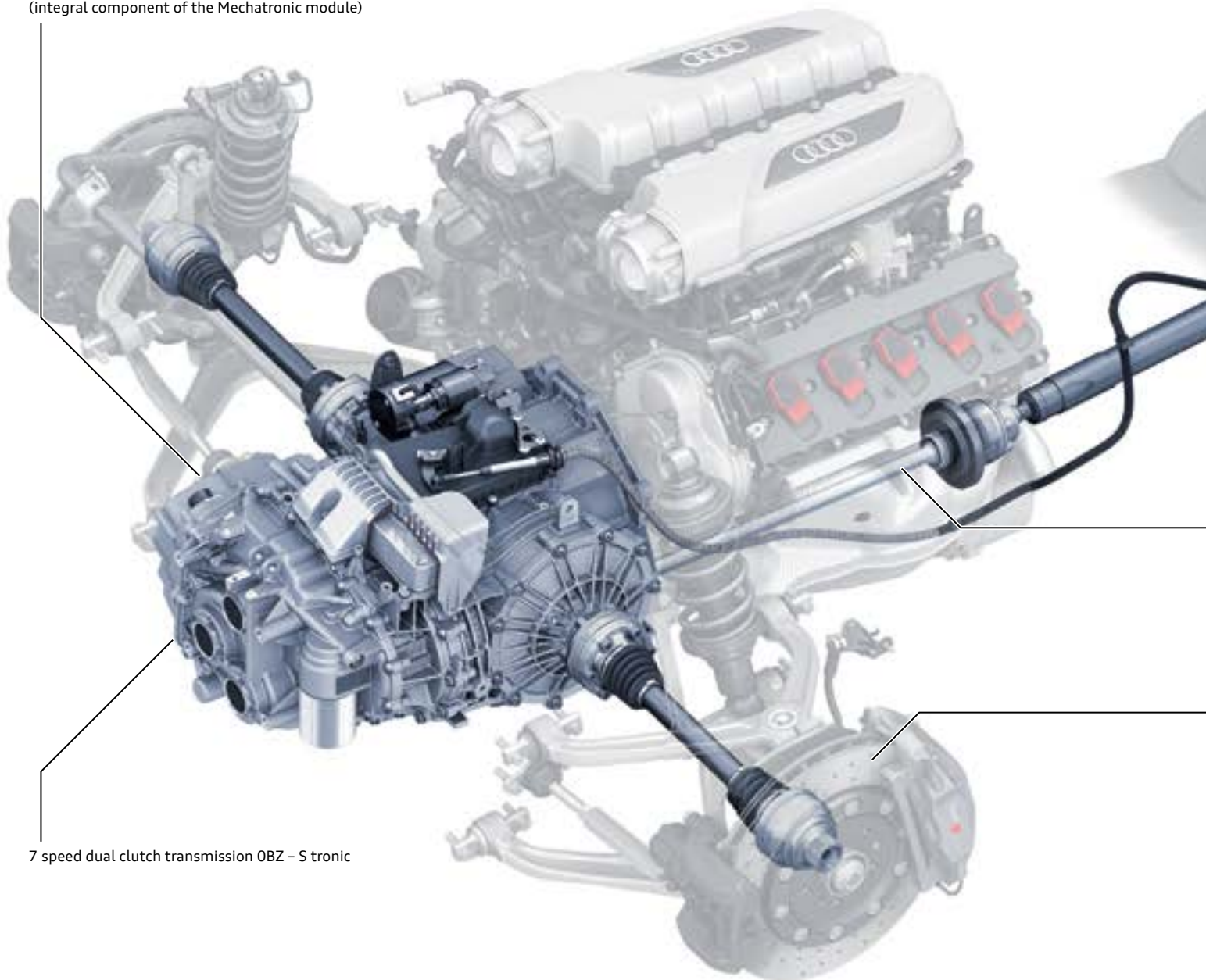

7 speed dual clutch transmission OBZ - S tronic

The Audi drive select handling system allows the driver to select different setups for the transmission and the all-wheel drive clutch. It is possible to experience driving dynamics ranging from comfortable and balanced to particularly sporty.

The new performance mode on the V10 plus provides sporty transmission and driving dynamics setups (refer to page 48 and 63).

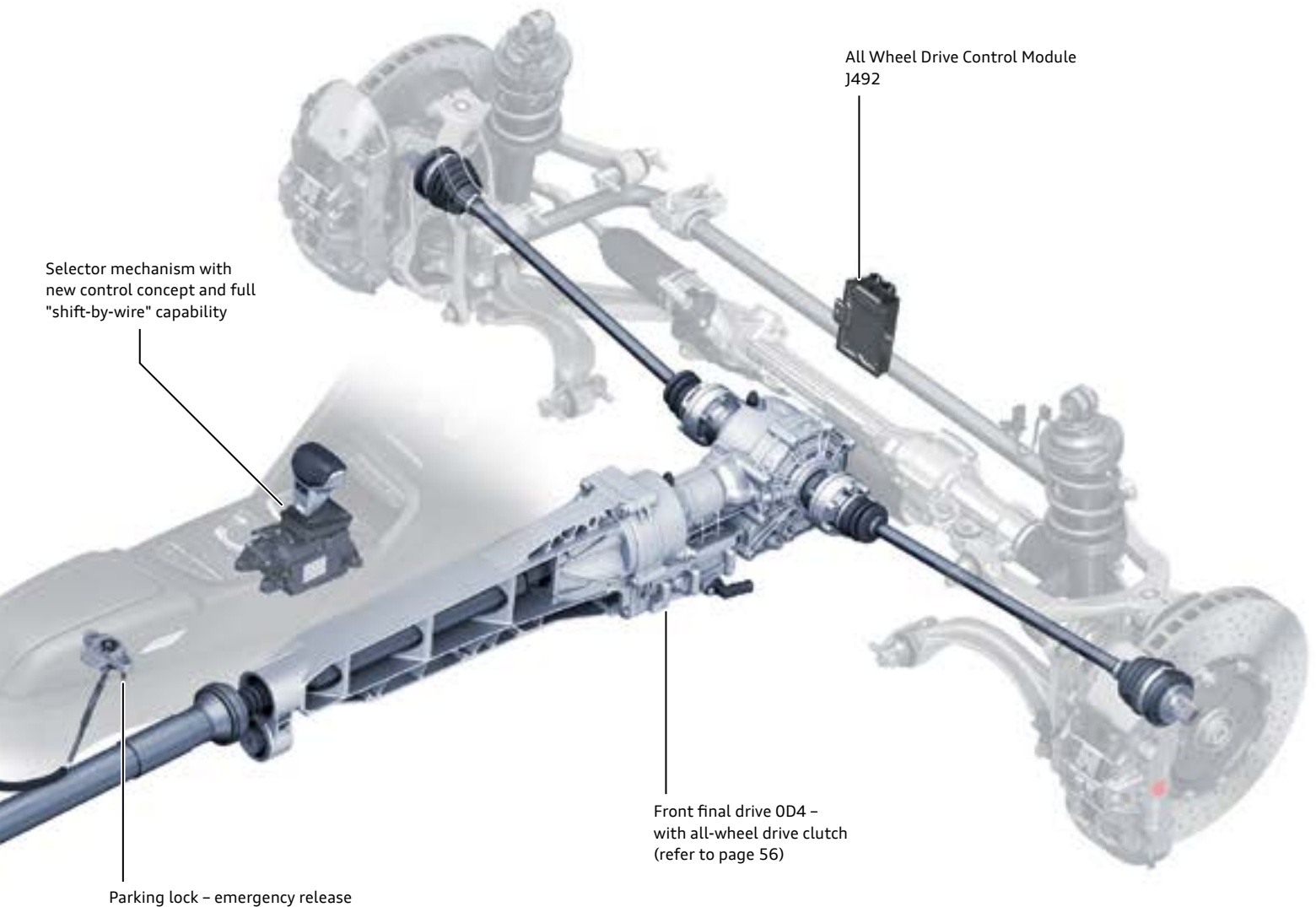

Selector mechanism with new control concept and full "shift-by-wire" capability

All Wheel Drive Control Module J492

Front final drive OD4 – with all-wheel drive clutch (refer to page 56)

Parking lock – emergency release

641\_046

Drive shaft

The drive shaft transmits the drive torque from the transmission output shaft to the propeller shaft. It is located inside the engine (it runs through the engine oil pan), and is not visible from the exterior (page 53 and 56).

Torque vectoring at both axles.



**Reference**

For further information about the front final drive OD4, refer to [eSelf Study Program Self-Study Program 950163, Final drive OD4.](#)

## Selector mechanism

The Audi R8 uses the latest generation Audi selector mechanism of the B and C vehicles with full "shift-by-wire" capability.

The parking lock is normally engaged and disengaged using the Auto P function, but can also be engaged by the driver using the P button (refer to page 46).

After every operation, the selector lever always returns to the normal position of the automatic or Tiptronic gate.

## Basic shift schematic

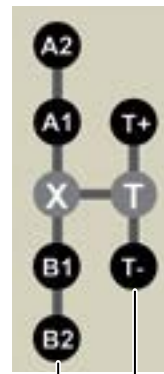

Possible positions of the selector lever:  
Normal position X in automatic mode or normal position T in Tiptronic mode.

Depending on the selector lever position, this position information (A1, A2 etc.) can be displayed in the Measuring values using the VAS Scan Tool.

641\_047

Automatic gate  
Tiptronic gate

## Shift schematic

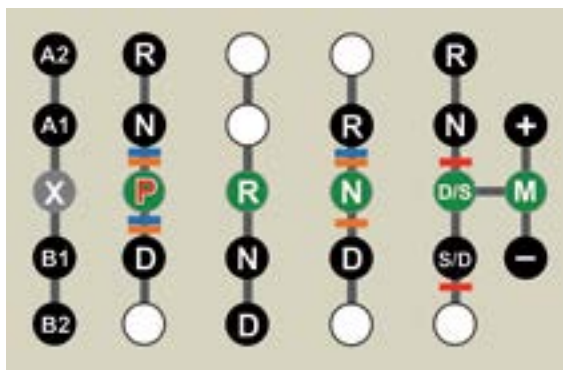

641\_048

- Positions selectable without moving the selector
- Selectable driving positions
- Normal position of the selector lever and current driving position
- Software lock: deactivate by pressing Selector Lever Release Button E681
- Software lock: deactivate by pressing the foot brake<sup>1)</sup>
- Mechanical locking by Shift Lock Solenoid N110- Deactivate by pressing Selector Lever Release Button E681

**Note: an acknowledgement tone sounds whenever driving position R is selected.**

## Automatic gate



641\_049

## Tiptronic gate



641\_050

## Speed-dependent transmission protection function

A change in driving direction from D to R and vice versa is only possible at a driving speed below 5.0 mph (8 km/h). Upwards of a driving speed of 5.0 mph (8 km/h), a transmission protection function prevents the travel direction from being reversed.

<sup>1)</sup> The orange-colored software lock is activated in driving position N after about one second. This allows quick-changing of the driving position from D to R and vice versa without applying the brake. This makes it possible, for example, to free a stuck vehicle by rocking it backwards and forwards and makes it easier to shift driving position when maneuvering.



## Component overview

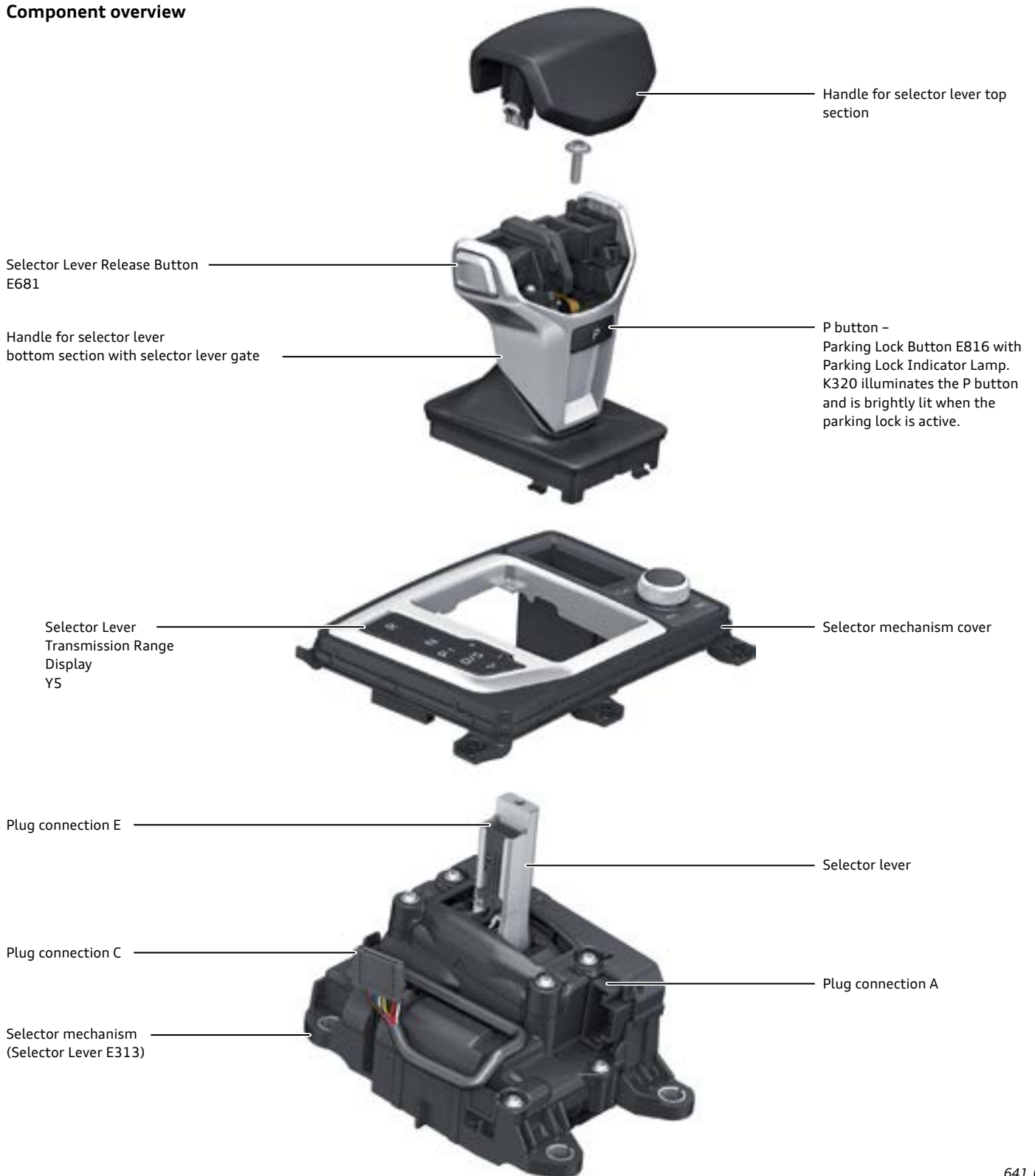

641\_051

### Selector Lever Release Button E681

E681 is used to release the selector lever lock. It has two shift elements for reliability and diagnostics. If E681 fails, it is considered actuated. The red and blue locks (illustration 641\_048) are disabled and a DTC is registered. A message is displayed in the DIS for the driver. The selector lever can be moved out of the P and N positions while pressing the foot brake.

### Parking Lock Button E816

The P button is for manual deactivation of the parking lock. The parking lock can only be activated if the vehicle is traveling less than 0.6 mph (1 km/h). E816 has three shift elements for reliability and diagnostics. Its status is transferred to Selector Lever Sensor System Control Module J587 via two interfaces. In the event of a fault, a DTC is registered and a message appears in the DIS to alert the driver. The parking lock can only be engaged by the Auto P function.

# Transmission functions

## Auto-P function

The parking lock is operated electro-hydraulically. This allows the TCM to automatically engage the parking lock which in turn enhances operating ease.

The Auto-P function engages the parking lock automatically (**P-ON position**) if:

- > The vehicle is stationary – travelling at a speed of less than 0.6 mph (1 km/h).
- > One of the following driving positions is engaged: **D, S, R** or **M**.
- > The engine is shut off – terminal 15 off.

The parking lock can also be engaged by the driver by pressing the P button, provided that the vehicle is travelling slower than 0.6 mph (1 km/h).

The parking lock is disengaged automatically (**P-OFF position**) if the engine is running and driving position **D, S, R, N** or **M** is selected.

## Tip shifting in D/S

Manual gearshifts can be performed at any time using the shift paddles on the steering wheel (tiptronic steering wheel) in driving positions **D/S**. If the tiptronic steering wheel is operated, the transmission runs **continuously** in manual mode (tiptronic mode).

There are two options for returning to automatic mode:

- > Pull the selector lever back one position (position B1).
- > Move the selector lever into the tiptronic gate and back into the automatic gate.

## Activating driving position N (P-OFF position)

To be able to briefly move the vehicle without the parking lock for example, in a car wash, automatic engagement of the parking lock can be prevented.

A condition for this is that the selector mechanism, the P button and the transmission are functioning properly.

To activate the **P-OFF position**, driving position **N** must be selected when the engine is running, and then the engine must be shut off.

When the ignition is switched off, engagement of the parking lock will be suppressed for 20 minutes.

After 19 minutes the following message is displayed in DIS: *"Start engine to remain in N."* together with a warning tone. If this instruction is not followed, the parking lock will be engaged after 20 minutes and the system will shut down.

If a vehicle speed signal is detected during this period, the period will be extended according to the driving time of the vehicle until a stationary time of at least 5 minutes is detected.

During the stopping period in the **P-OFF position**, electrical power is consumed by the activity of control modules, bus operation and the holding magnet. If the vehicle is held stationary for a lengthy period of time, the battery may become discharged to the extent that the parking lock automatically engages itself.

If it is necessary to hold the parking lock in the **P OFF position** for longer, the parking lock emergency release mechanism must be actuated (refer to page 50).

## Launch control program

The Launch Control Program regulates the maximum acceleration of the vehicle from a standing start. Refer to the Owner's Manual for operating instructions and other information.

## Special features of the tiptronic steering wheel

The following functions can be selected in the Audi R8 using the shift paddles on the steering wheel:

- > If both shift paddles are operated simultaneously while the engine is running, driving position **N** is selected (while moving and when the vehicle is stationary).
- > When the vehicle is stationary, the driver can shift from driving positions **P, R, N** to **M1** by actuating the Tip+ shift paddle with the brake applied.
- > If the Tip+ shift paddle is continuously actuated while driving, the vehicle shifts into the highest available gear, for example, from 3rd to 5th gear. If the Tip- shift paddle is continuously actuated, the vehicle shifts into the lowest available gear, for example, from 7th to 3rd gear.
- > If a system malfunction has occurred in the selector mechanism, the driver can select driving position **D** with the Tip+ shift paddle when the vehicle is stationary while pressing the brake pedal. **N** can be selected by actuating both shift paddles simultaneously. Reverse gear is not available.

These additional functions of the tiptronic shift paddles are made possible by the redundant transfer of the shift commands from both shift paddles. The shift commands are first transmitted by CAN data bus to Transmission Control Module J217 and **additionally** by 2 separate wires to Automatic Transmission Control Module 2 J1006. This information is, in turn, sent from here to J217 by CAN data bus.



641\_052

## Audi drive select – transmission setups

In addition to the well-known Audi drive select modes, **comfort – auto – dynamic – individual**<sup>1)</sup>, the Audi R8 has a performance mode. Performance mode itself has three characteristics – **snow**, **wet** and **dry**. These characteristics allow the handling systems to be better adapted to the road surface conditions, that is, the friction between the tires and the road surface.

The Audi drive select handling system utilizes the electronic stability control (ESC) system in performance mode.

### The comfort, auto and dynamic modes

The **comfort** and **auto** modes are identical regarding transmission setup. The shift points and the gearshifts are comfort-oriented.

In **dynamic** mode the sport program **S** is selected in the transmission. In the sport program the shift points are at higher engine speeds and shift times are reduced. This makes for better power delivery and more noticeable gearshifts.

The overview on page 49 shows the effects of the various Audi drive select modes on the transmission setup.

<sup>1)</sup> In **individual** mode, the driver can choose a transmission setup independent from other vehicle systems.

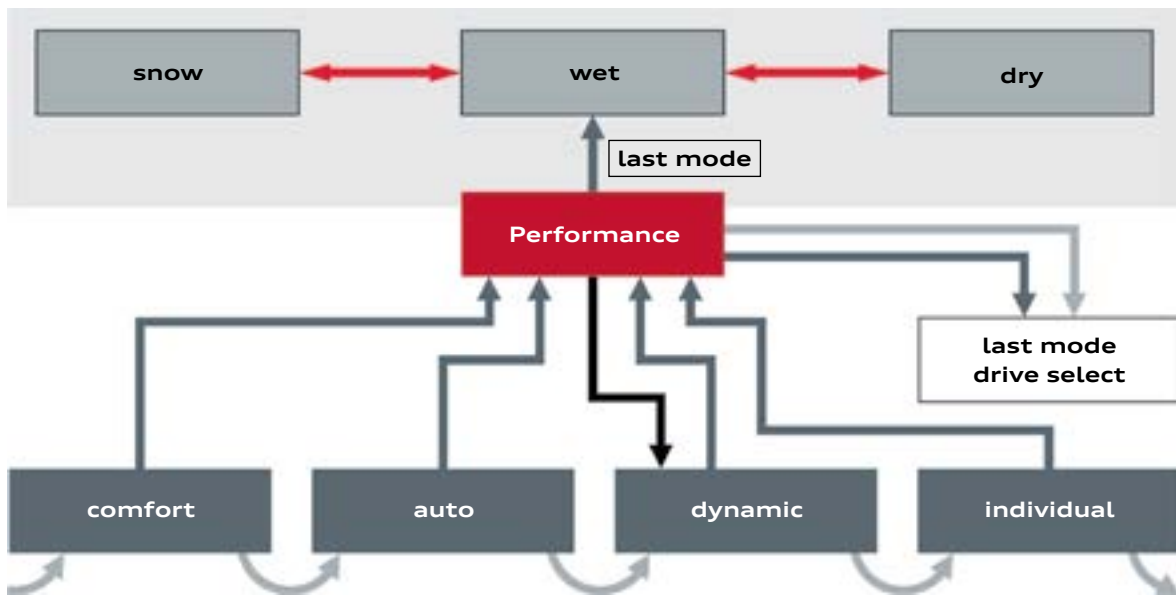

Key:

- Performance button
- Performance button adjusting ring
- Audi drive select button/MMI turn-and-press knob
- Terminal 15 change-over

641\_038

### Performance mode

In performance mode, the transmission setup is extremely sporty. This means that the transmission works to maximize power delivery from the engine. Comfort plays a secondary role here. Gearshifts are performed at very high engine speeds, and the shift times are extremely short and noticeable.

Performance mode can only be activated and operated using the Performance button on the steering wheel. The Performance button allows the driver to activate or deactivate performance mode directly and in any Audi drive select mode.



#### Note

Please note that the stabilization functions of the ESC and TSC systems are limited after activating performance mode. You should only activate performance mode if you have the necessary driving skills and the traffic conditions permit.

## Performance button

The Performance button is a touch switch with an adjusting ring. The adjusting ring is used to select the **snow**, **wet** and **dry** modes. These modes do not, however, have different transmission characteristics.

Performance mode is standard in the V10 plus and optional for the V10.



Audi drive select button

Performance button with adjusting ring for selecting the snow, wet and dry modes

641\_054

## Overview of transmission setups available with Audi drive select

Audi drive select Mode Transmission setups and functions	comfort		auto		dynamic = sport program		Performance No distinction is made between dry, wet and snow	
	D	M <sup>1)</sup>	D	M <sup>1)</sup>	S	MS <sup>1)</sup>	S+	MS+ <sup>1)</sup>
Driving position <sup>5)</sup>	D	M <sup>1)</sup>	D	M <sup>1)</sup>	S	MS <sup>1)</sup>	S+	MS+ <sup>1)</sup>
Shift characteristics	normal	-	normal	-	sporty	-	super sporty	-
Automatic upshifting in M mode	-	Yes	-	Yes	-	No	-	No
Downshift during-kickdown in M mode	-	Yes	-	Yes	-	No	-	No
Modified accelerator map, increased idling and driveaway speed	normal				sporty		super sporty	
Launch control program	No		No		Yes – with automatic upshift into M and with the sportiest shift sequence and shortest possible shift time			
Blipping the throttle during downshift	No	Yes	No	Yes	Yes			
Shift sequence/shift time	A	C	A	C	B	C	B	D
Return to automatic mode after actuating the tiptronic shift paddles	No	-	No	-	No	-	No	-
Engine start/stop mode	Yes				No			
Cylinder-on-demand <sup>4)</sup>	Yes				No			

### Key to shift sequence:

- A Comfort-oriented overlapping gearshift with engine torque intervention<sup>3)</sup>
- B Shift-time-oriented overlapping gearshift with maximum engine torque intervention
- C High-speed overlapping gearshift with maximum engine torque intervention – specially adapted for tiptronic operation
- D Fastest possible overlapping gearshift with maximum engine torque intervention and utilization of engine drag torque during upshifting

<sup>1)</sup> M denotes: manual shift program tiptronic, MS denotes: manual shift program tiptronic Sport, MS+ denotes: manual shift program Sport-Plus.

<sup>3)</sup> For more information about the "overlapping gearshift with engine torque intervention", [eSelf-Study Program 950143, Audi 0B5 7 Speed S tronic Transmission](#).

<sup>4)</sup> Cylinder-on-demand (refer to page 34).

<sup>5)</sup> The specified driving position is pre-defined by selecting Audi drive select mode. However, it is possible to shift from D to S, and vice versa, at any time. It is also possible to shift into tiptronic mode.

## Emergency-releasing the parking lock

During normal operation, the parking lock is electro-hydraulically actuated. This requires that the engine is running to generate sufficient ATF pressure. Holding the parking lock in the OFF position also requires sufficient ATF pressure or that the parking lock holding magnets have a sufficient voltage supply.

If it is necessary to hold the parking lock in the OFF position for longer, an emergency release procedure can be initiated.

The emergency release mechanism of the parking lock must be actuated in the following situations:

- › If it is necessary to tow the vehicle.
- › If the parking lock cannot be released electro-hydraulically due to a malfunction.
- › If the vehicle cannot be maneuvered or moved due to insufficient battery voltage.
- › If the engine is not running and it is necessary to maneuver or move the vehicle, for example, in the workshop.
- › For function testing after carrying out assembly work on components of the emergency release mechanism.

### Emergency-releasing the parking lock (P-OFF position)

The parking lock is emergency-released from inside the vehicle by a cable pull.

The socket wrench and the screwdriver needed to perform the procedure are located in the tool kit.

**Warning! Before actuating the emergency release mechanism of the parking lock, the vehicle must be secured to prevent it from rolling away.**

When the parking lock emergency release mechanism is actuated, the yellow gearbox warning lamp and the gear selector position indicator **N** are lit up in the DIS. The following message is also displayed: *"Vehicle may roll away! P cannot be selected. Please apply parking brake."*

### Deactivating the emergency release mechanism (P-ON position)

The emergency release mechanism is deactivated in reverse order.

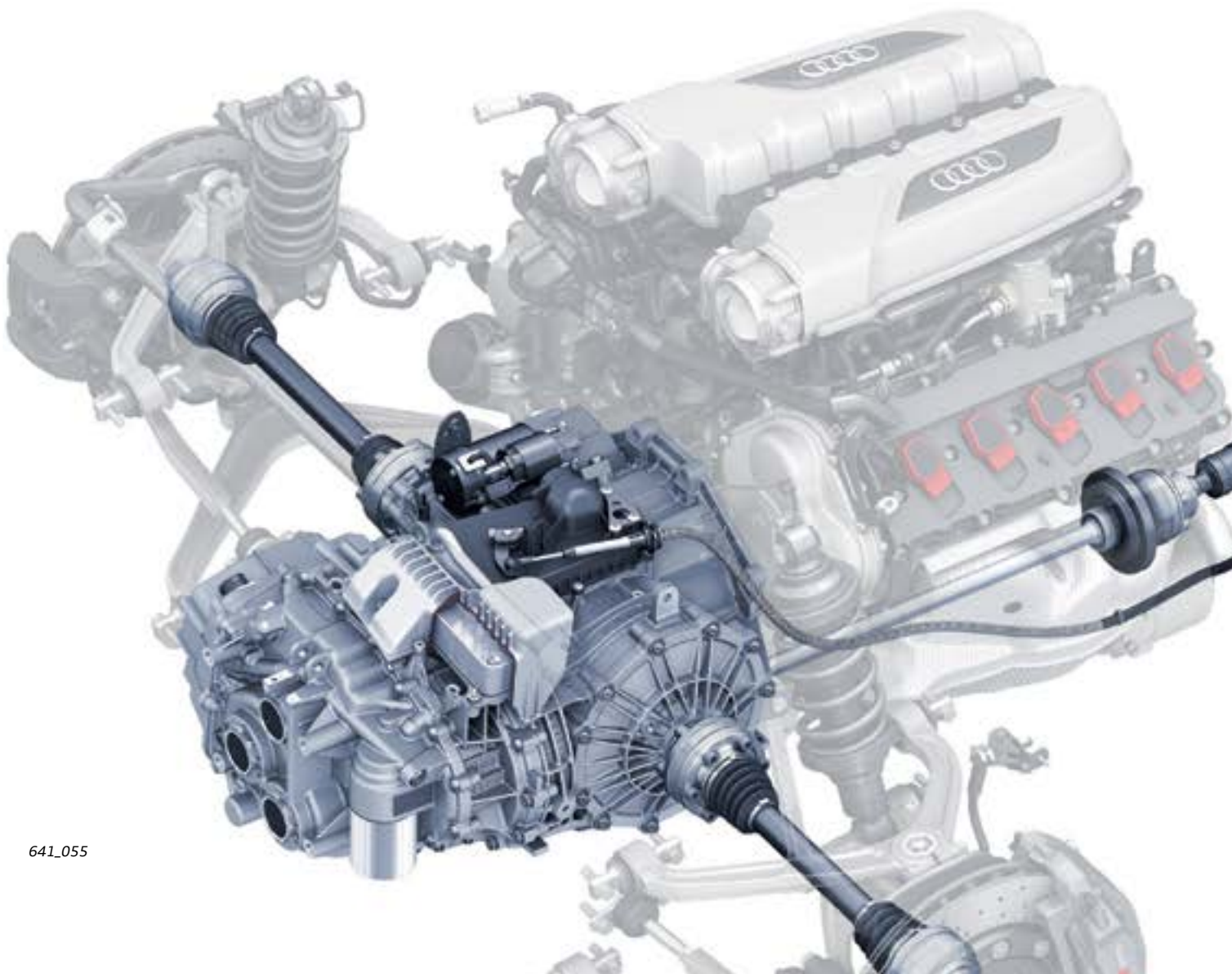



## Operation

1. Remove inlay from cupholder.
2. Remove the cover with a screwdriver. Remove the screw, push the release tab (arrow) and take out the cover.
3. Fold the socket wrench as shown and insert it into the actuating mechanism.

641\_053



4. Fold the socket wrench as shown and move it into position.

Actuating mechanism

Direction of travel

641\_056

641\_057

## Transmission overview

Designations	Manufacturer	DL800-7A
	Service	OBZ
	Sales	S tronic
Development/production	Audi AG Ingolstadt/VW plant Kassel	
Type	Full synchromesh three-shaft with 7 forward gears and one reverse gear, electro-hydraulically operated transmission for mid-engine concept, with limited slip differential in the final drive to the rear axle and transmission output shaft for the final drive to the front axle	
Dual clutch	Two wet-type multi-plate clutches in an in-line configuration, electro-hydraulically operated and oil-cooled	
Control system	Mechatronic unit plus two additional electro-hydraulic modules (parking lock module and auxiliary hydraulic module) – shift-by-wire operation with electro-hydraulically operated parking lock, dual control unit concept for shift-by-wire technology and separate clutch cooling system for clutch K1/K2. Automatic mode with various shift programs and tip-tronic program for manual gear-shifting.	
Ratio configuration	<ul style="list-style-type: none"> <li>&gt; 6 plus overdrive configuration on the R8 (the 7th gear has a long ratio for fuel economy)</li> <li>&gt; 7 speed configuration on the R8 plus</li> </ul>	
Weight	311 lb (141 kg) ATF and dual mass flywheel	

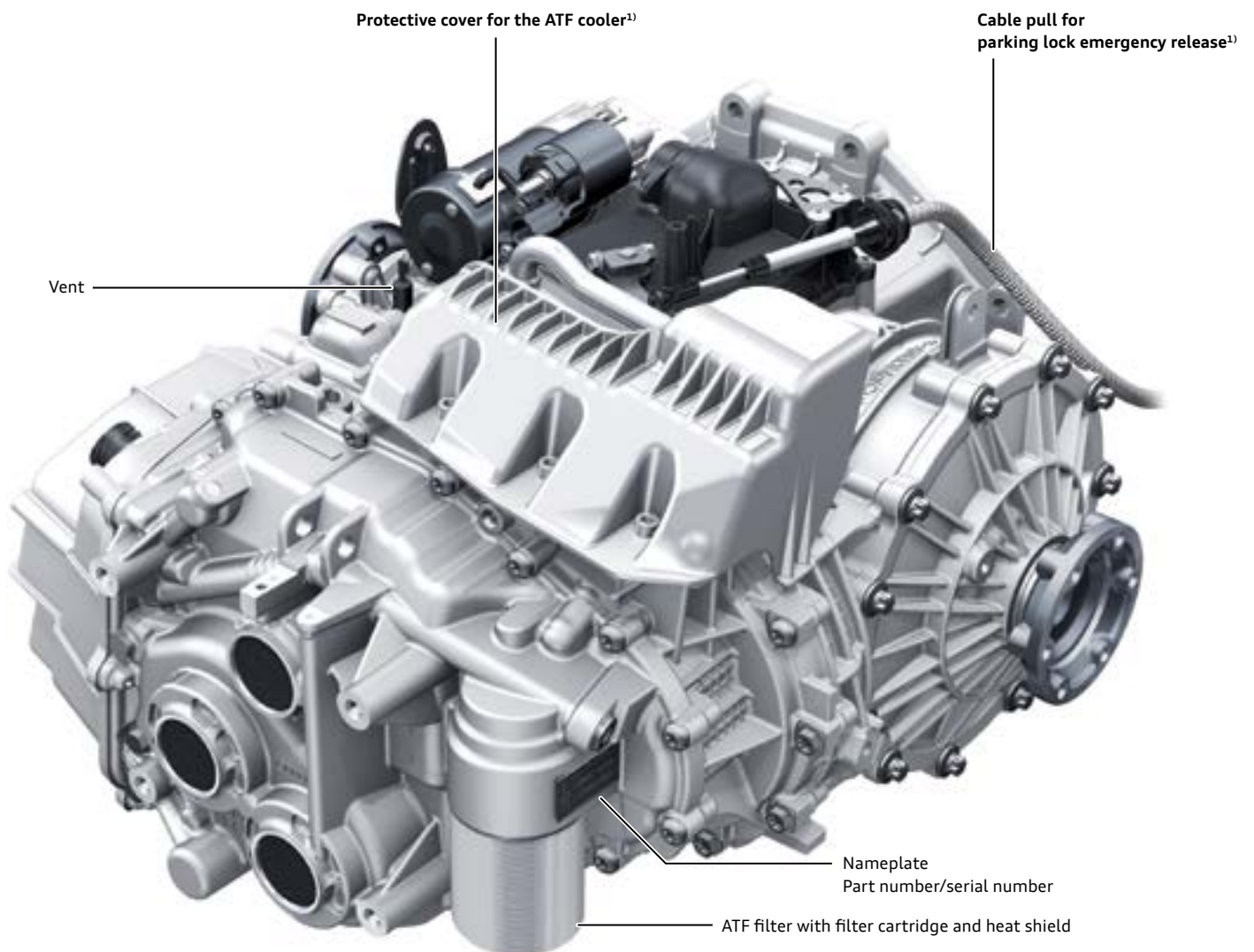

641\_058

<sup>1)</sup> Innovations, modifications and special features of the OBZ transmission in the 2017 Audi R8.



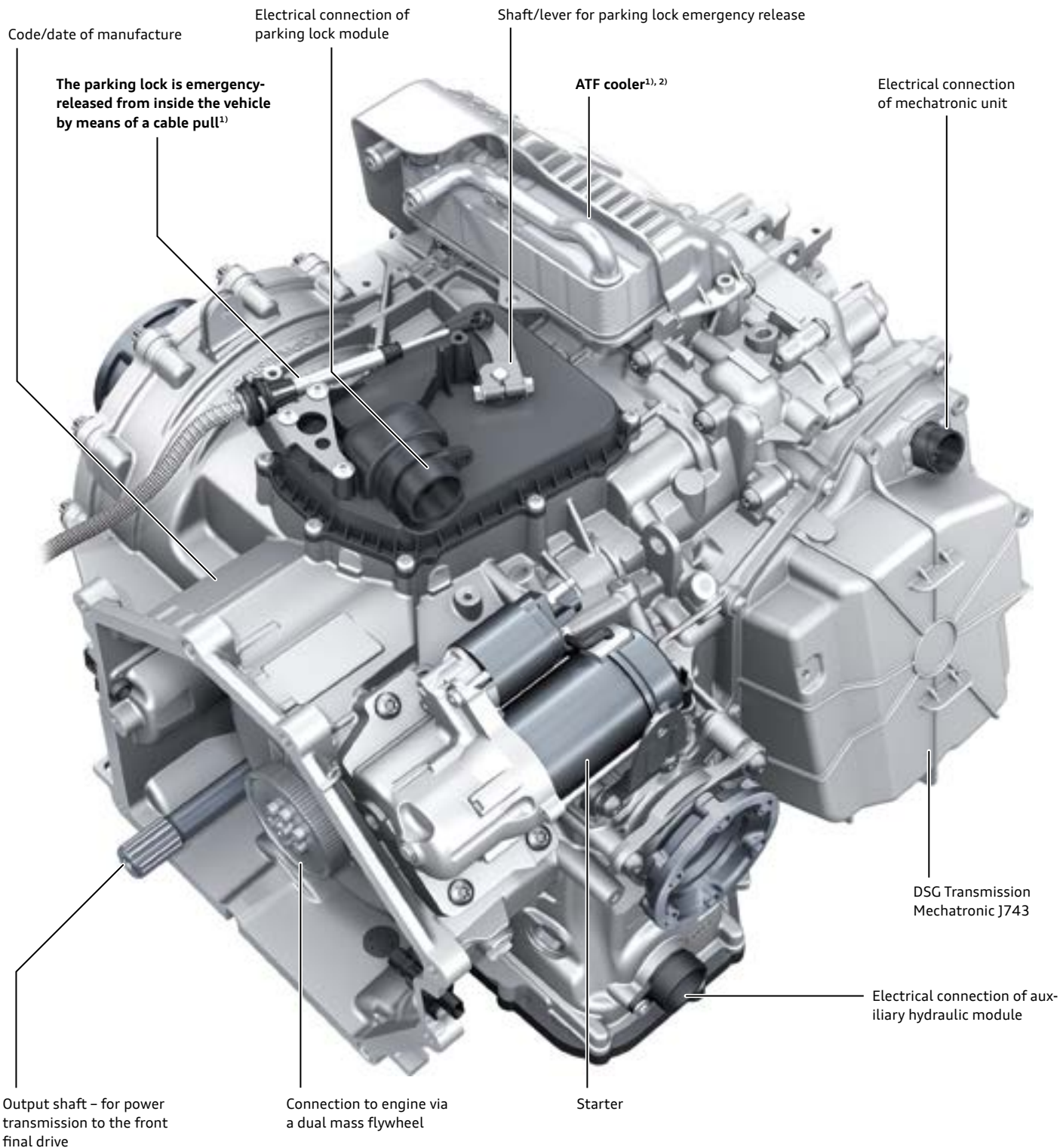

641\_059

## Transmission case

The transmission case consists of three aluminum sections in which nearly all the oil ducts are integrated. The cover for the clutch, the final drive and the Mechatronic module is also made of aluminum. The cover for the parking lock and the oil pan with integrated suction filter are made of high-grade polymer.

## Lubrication system

The OBZ transmission has a common oil supply for all functional groups of the gearbox. The special ATF for the dual clutch gearbox currently has a maintenance interval of 40,000 mi (60,000 km). The ATF filter is replaced at the same time as the ATF is changed. Follow the instructions given the workshop manual and on the VAS Scan Tool when checking and changing the ATF.

<sup>1)</sup> Innovations, modifications and special features of the OBZ transmission in the 2017 Audi R8.

<sup>2)</sup> The overall height of the ATF cooler in the Audi R8 is less than in the predecessor model. The overall cooling concept of the vehicle/engine has been considerably revised, and no additional ATF cooler (air to oil heat exchanger) is required by either engine variant.

## Transmission assemblies

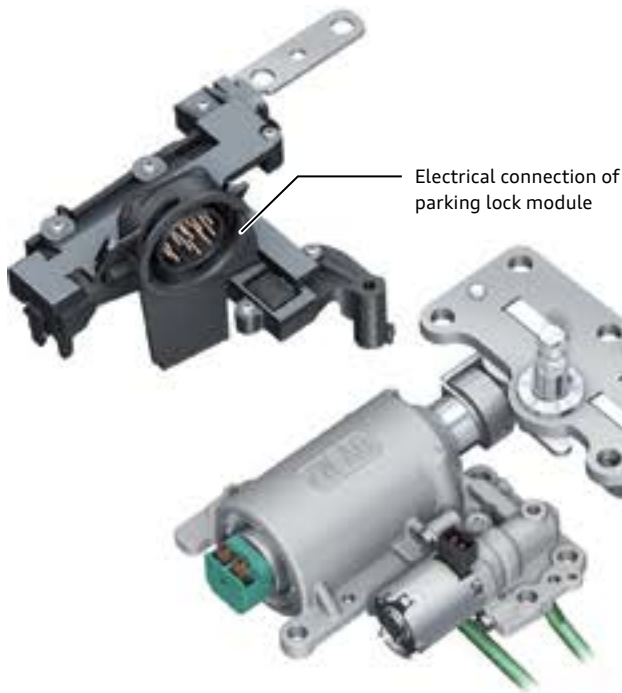

Electrical connection of parking lock module

### Parking lock module

- › Mechanical components for operation of the parking lock and emergency release mechanism
- › Hydraulic cylinder for hydraulic operation of the parking lock
- › Parking Lock Sensor G747
- › Parking Lock Solenoid N486 - Parking lock holding magnet
- › Parking Lock Solenoid Valve N573 - Parking lock engagement valve

Final drive with limited slip differential  
- reconfigured lockup torque values  
for the Audi R8 <sup>1)</sup>

Dual clutch

Different output shaft ratios are used for the front final drive to adapt the ratio configuration for both engine output versions.<sup>1)</sup>

The output shaft is also referred to as the PTO shaft. PTO stands for: power-take-off

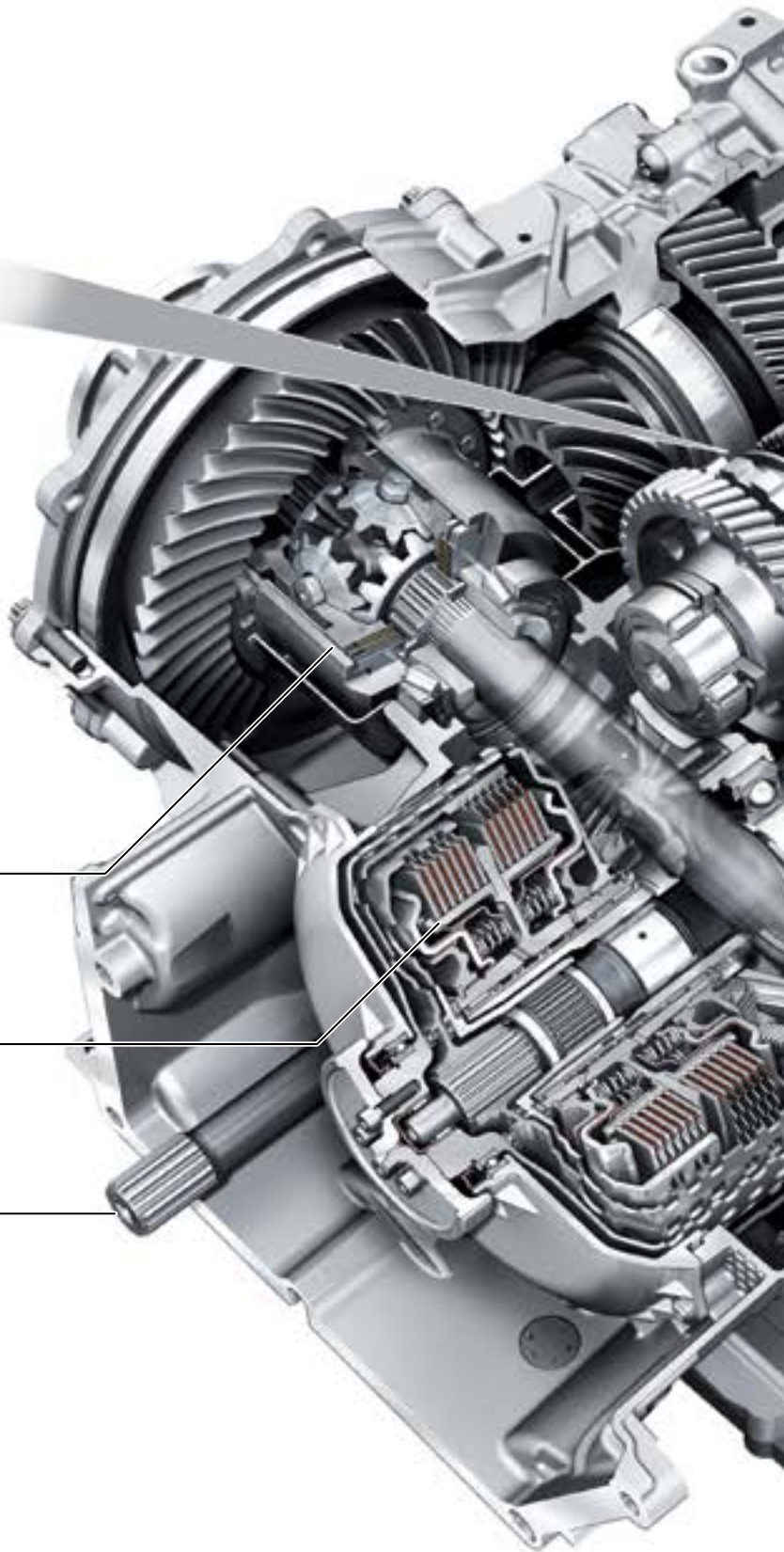

<sup>1)</sup> Innovations, modifications and special features of the OBZ transmission in the 2017 Audi R8 compared to the predecessor model.

Automatic Transmission Control  
Module 2 J1006 – new installation  
location<sup>1)</sup>



Parking lock gear



641\_060

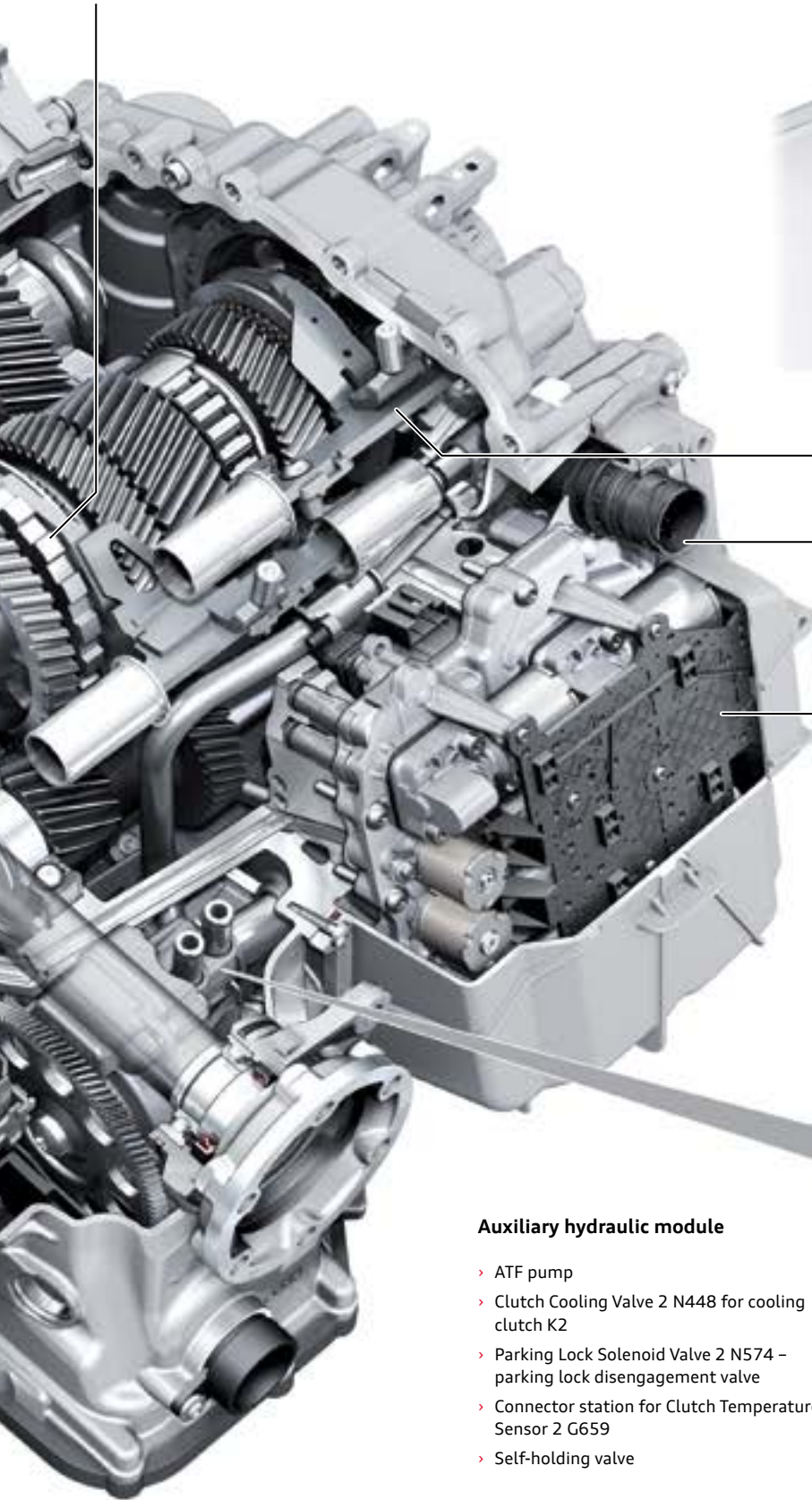

Hydraulically operated shift rail

Electrical connection of mechatronic unit

DSG Transmission Mechatronic J743  
with Transmission Control Module J217-  
J217 is integrated in the immobilizer<sup>1)</sup>

#### Auxiliary hydraulic module

- > ATF pump
- > Clutch Cooling Valve 2 N448 for cooling clutch K2
- > Parking Lock Solenoid Valve 2 N574 – parking lock disengagement valve
- > Connector station for Clutch Temperature Sensor 2 G659
- > Self-holding valve



Electrical connection for auxiliary hydraulic module

641\_061

## Front final drive OD4

The OD4 front final drive is a newly developed unit. It allows a fully variable distribution of torque to the front axle.

It is an electro-hydraulically controlled multi-plate clutch whose input shaft is permanently driven by the 7-speed S tronic transmission.

An intelligent traction and driving dynamics control system continuously monitors the driving situation, driver inputs and ambient conditions and uses this information to calculate an ideal torque split.

The all-wheel drive clutch is networked with the Audi drive select handling system, allowing it to be configured by the driver. Depending on which Audi drive select mode is selected, handling may be more neutral (**comfort** and **auto** modes) or more agile (**dynamic** mode). In performance mode, the all-wheel drive setup can be adapted to pre-defined road conditions (**snow**, **wet**, **dry**). The torque split is then optimally adapted to the road conditions and thus allows the fastest possible speeds to be achieved.

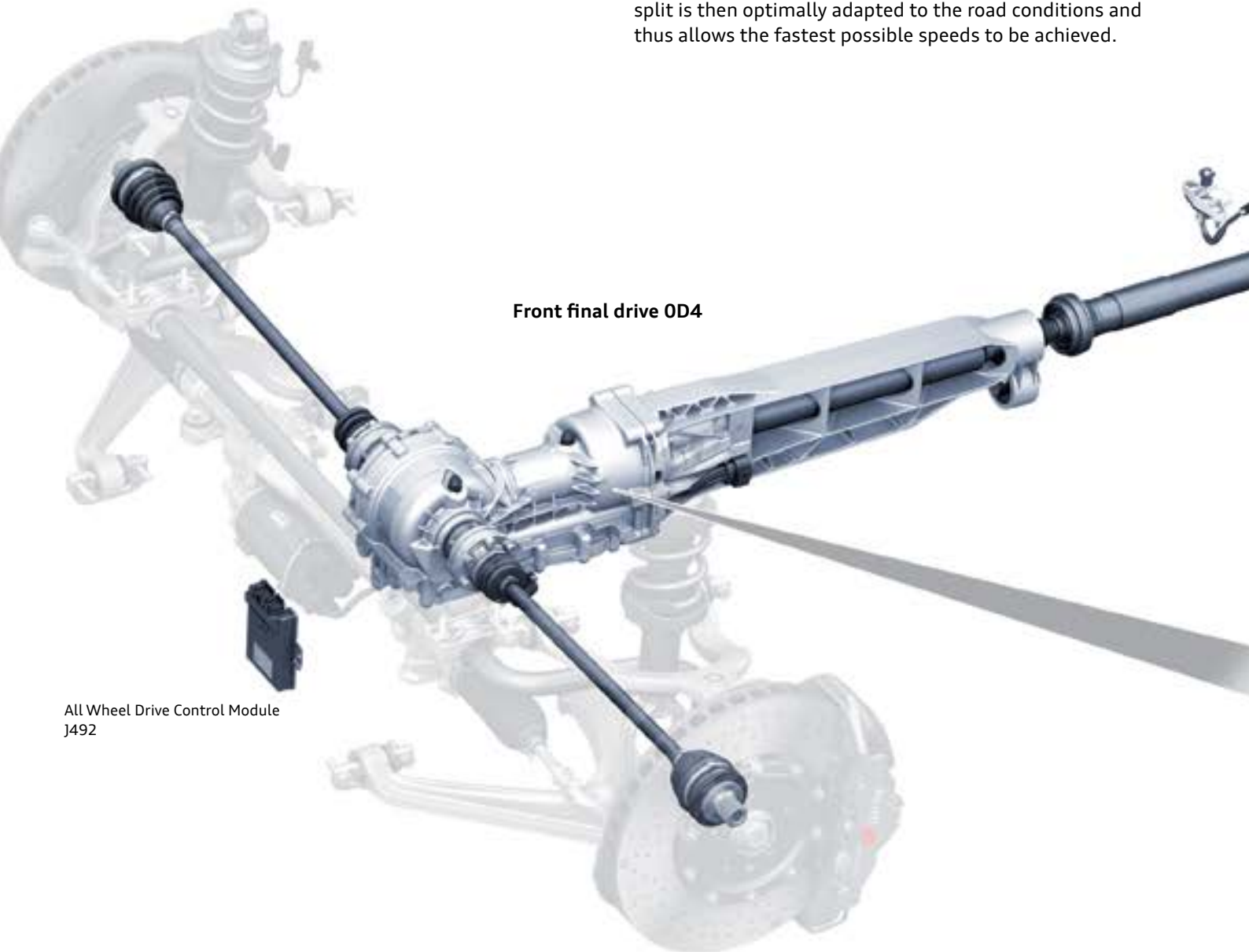

Front final drive OD4

All Wheel Drive Control Module J492

The new front axle differential and the special torque distribution setups provide not only excellent acceleration, but also outstanding driving dynamics in all road conditions.

The advance of the front wheels causes the quattro-clutch to slip at all times. A slipping clutch can be regulated which allows for more than 50% of the drive torque to be sent to the front axle.

Depending on the traction and dynamic control system, up to 406 lb ft (550 Nm) of clutch torque is transmitted to the front final drive. The distribution of torque is controlled continuously from heavily rear-biased to balanced. In extreme driving situations, up to 100% of available drive force may be transmitted to the front axle.

To ensure optimal torque distribution by the new quattro drive, the reconfigured mechanical limited slip differential improves traction and driving dynamics at the rear axle.



### Note

For more information refer to [eSSP 950163 Front final drive OD4](#).

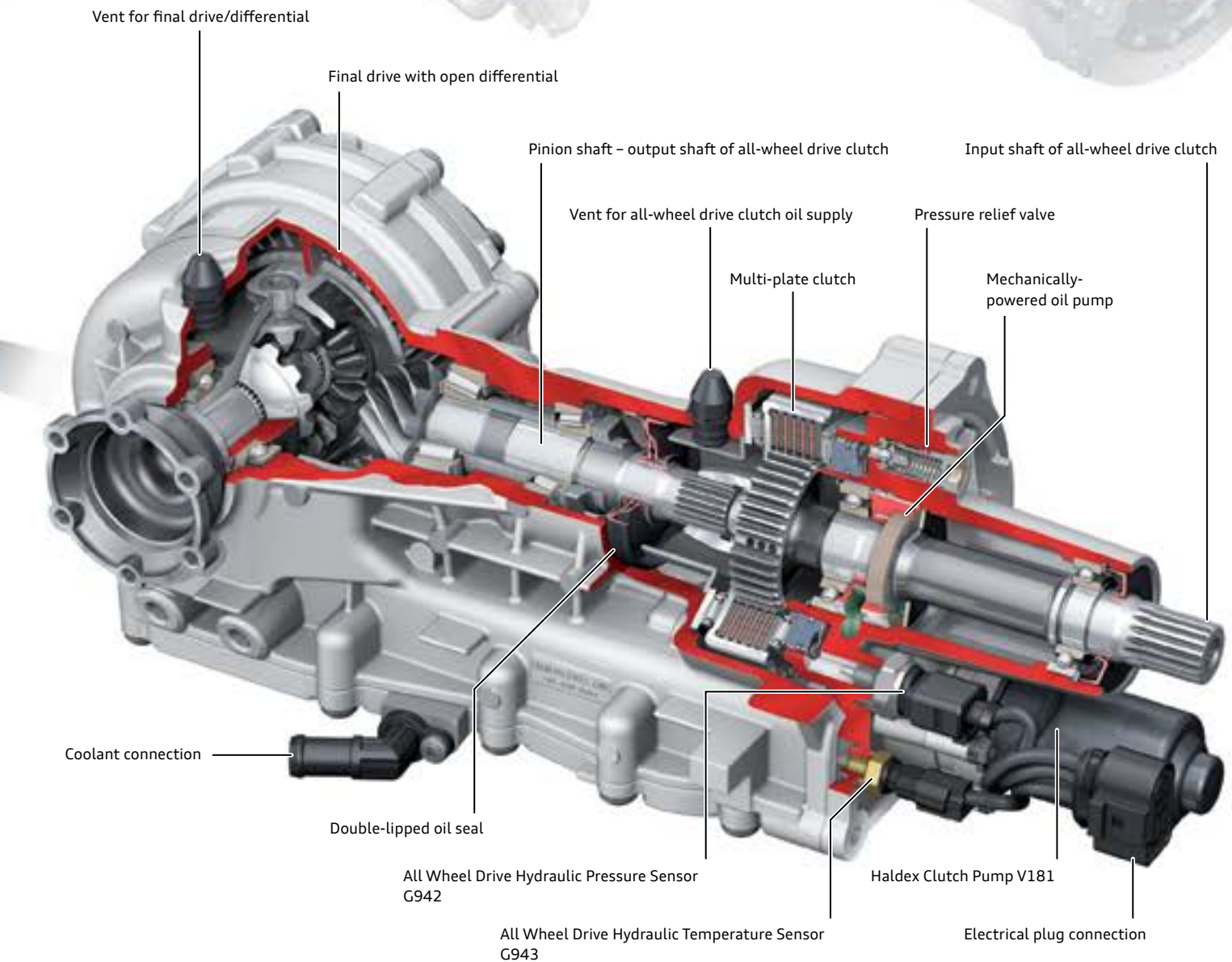
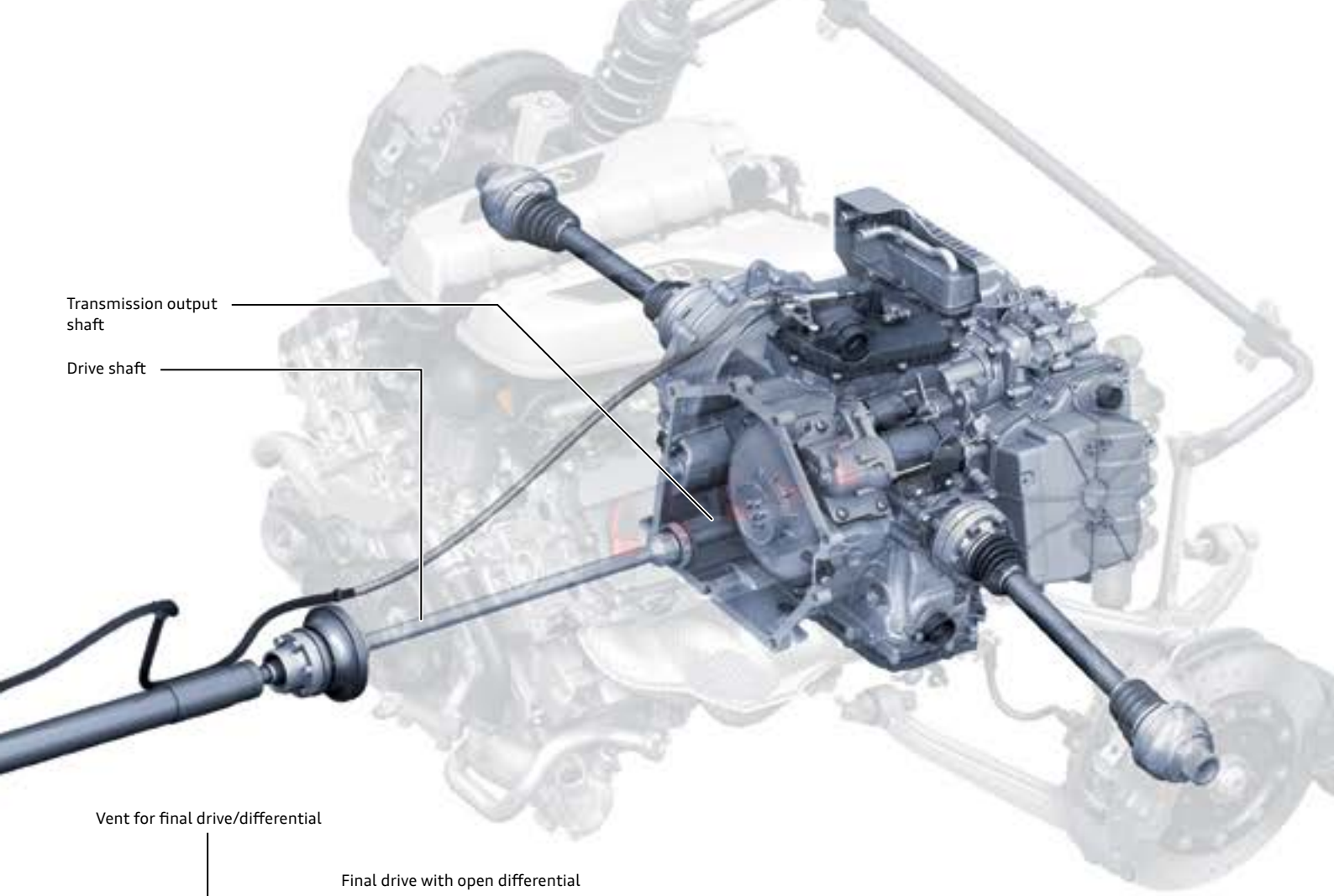

## Cutaway view

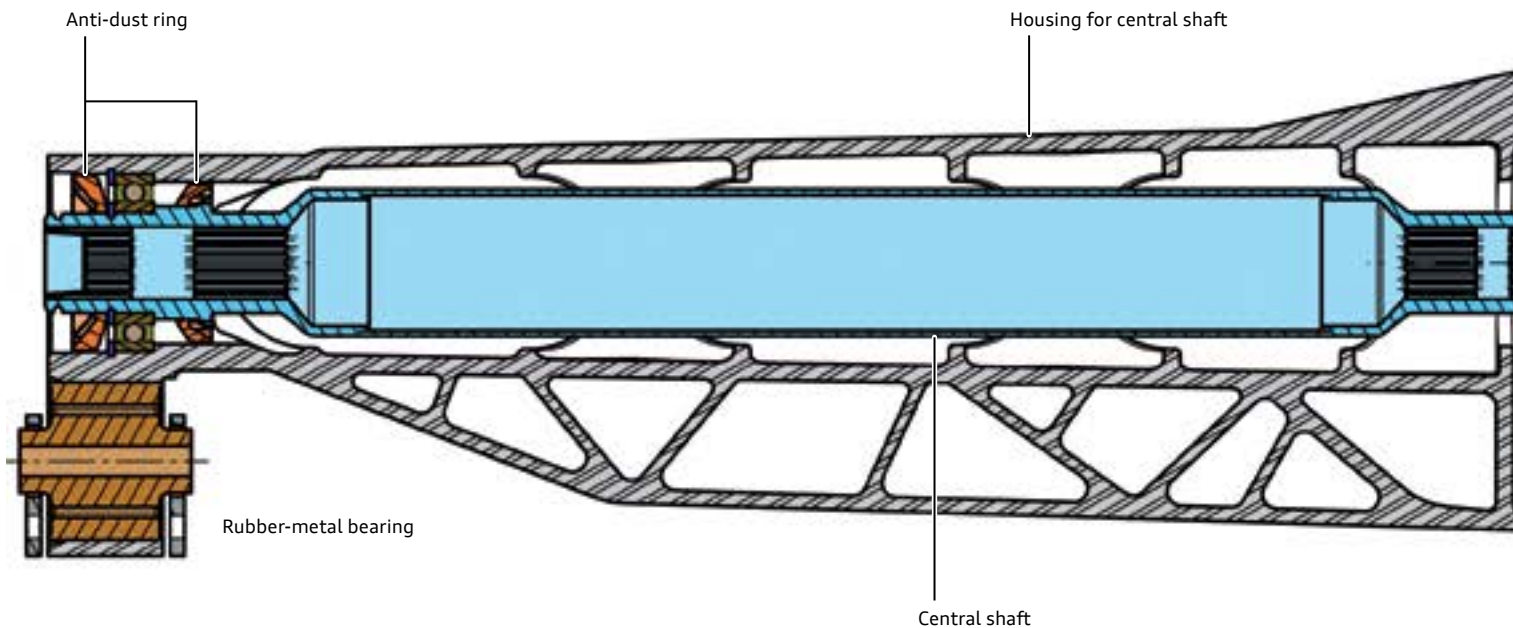

## Oil supplies

Final drive OD4 has two independent oil supplies with separate oil chambers. A double-lipped shaft seal and intermediate oil drainage port stops oil flowing to the other side in the event of a leak (refer to illustration „641\_062“4).

The Haldex oil and the axle oil currently have a change interval of 112,000 mi (180,000 km) or 10 ten years.

Follow the instructions given the workshop manual and on the VAS Scan Tool when checking and changing the oil in both supplies. Because the drain, filler and inspection plugs of both oil supplies are very close to one another, there is the possibility of a mix-up occurring. Use of the wrong oil will result in irreparable damage to the components.

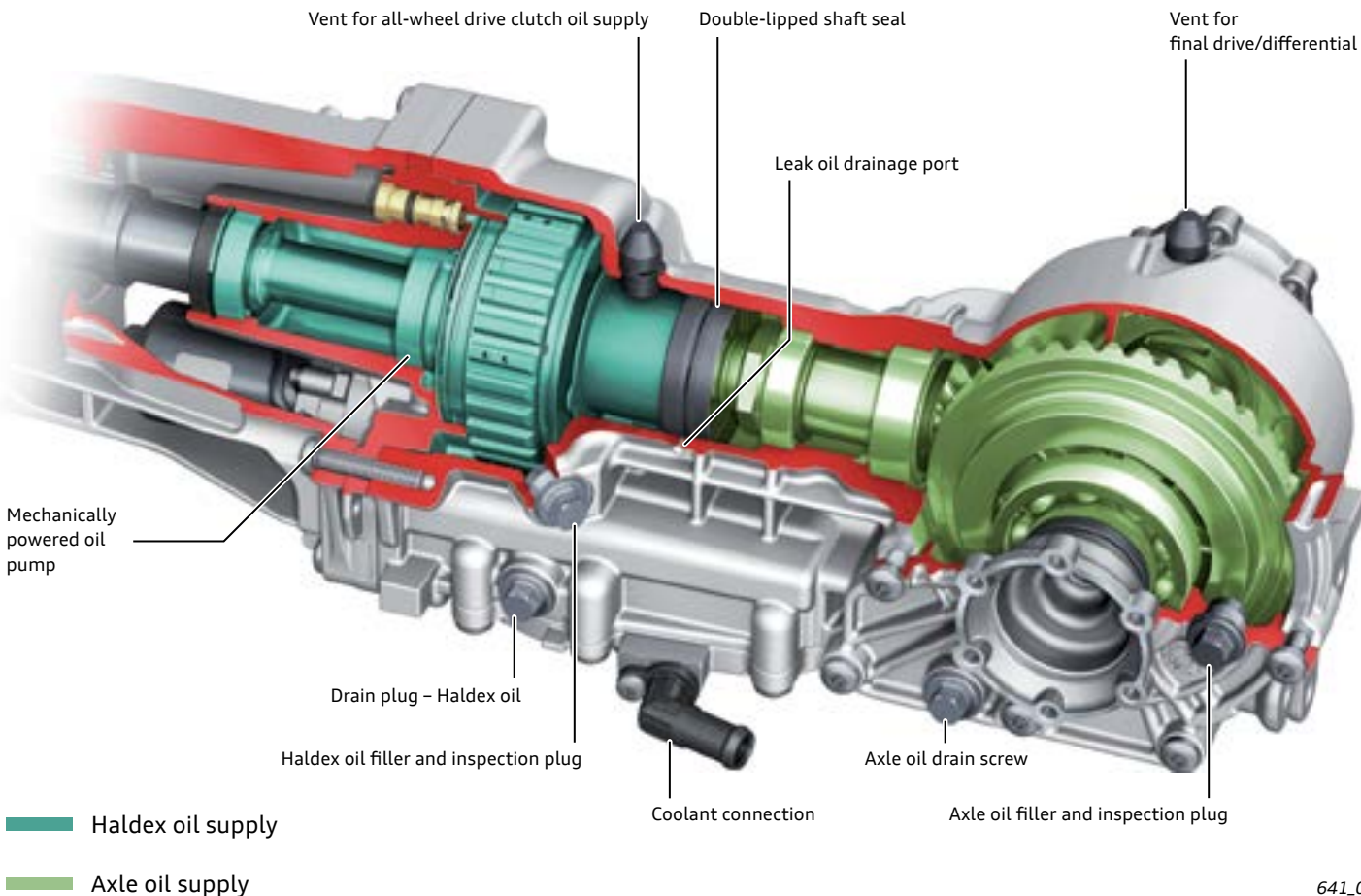

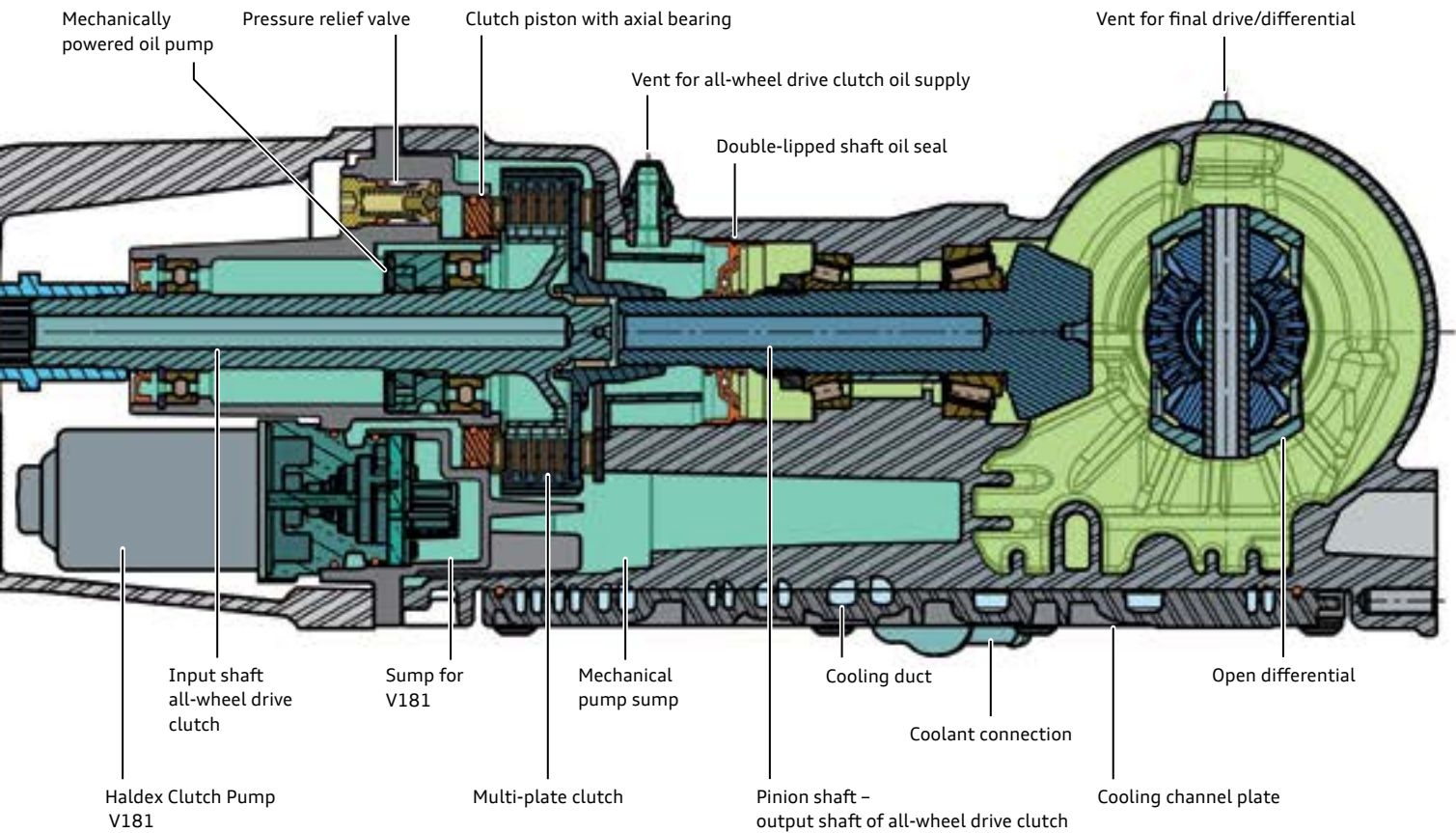

641\_063

## Cooling the front final drive

The all-wheel drive clutch principally limits torque by slipping. The clutch torque is increased in the all-wheel drive in accordance with the final drive ratio of 2.77:1. High power demand results in correspondingly high temperatures in both oil supplies.

To minimize the thermal stress on the oil in both supplies and to ensure that the system is available even under high power demand, the front axle differential has its own cooling system.

Coolant from the engine cooling system flows continuously through the base of the transmission (both oil supplies) via a cooling duct plate, dissipating heat.

All Wheel Drive Hydraulic Temperature Sensor G943 monitors the temperature of the Haldex oil. If the temperature of the Haldex oil exceeds a defined threshold, the Haldex clutch will not be activated.

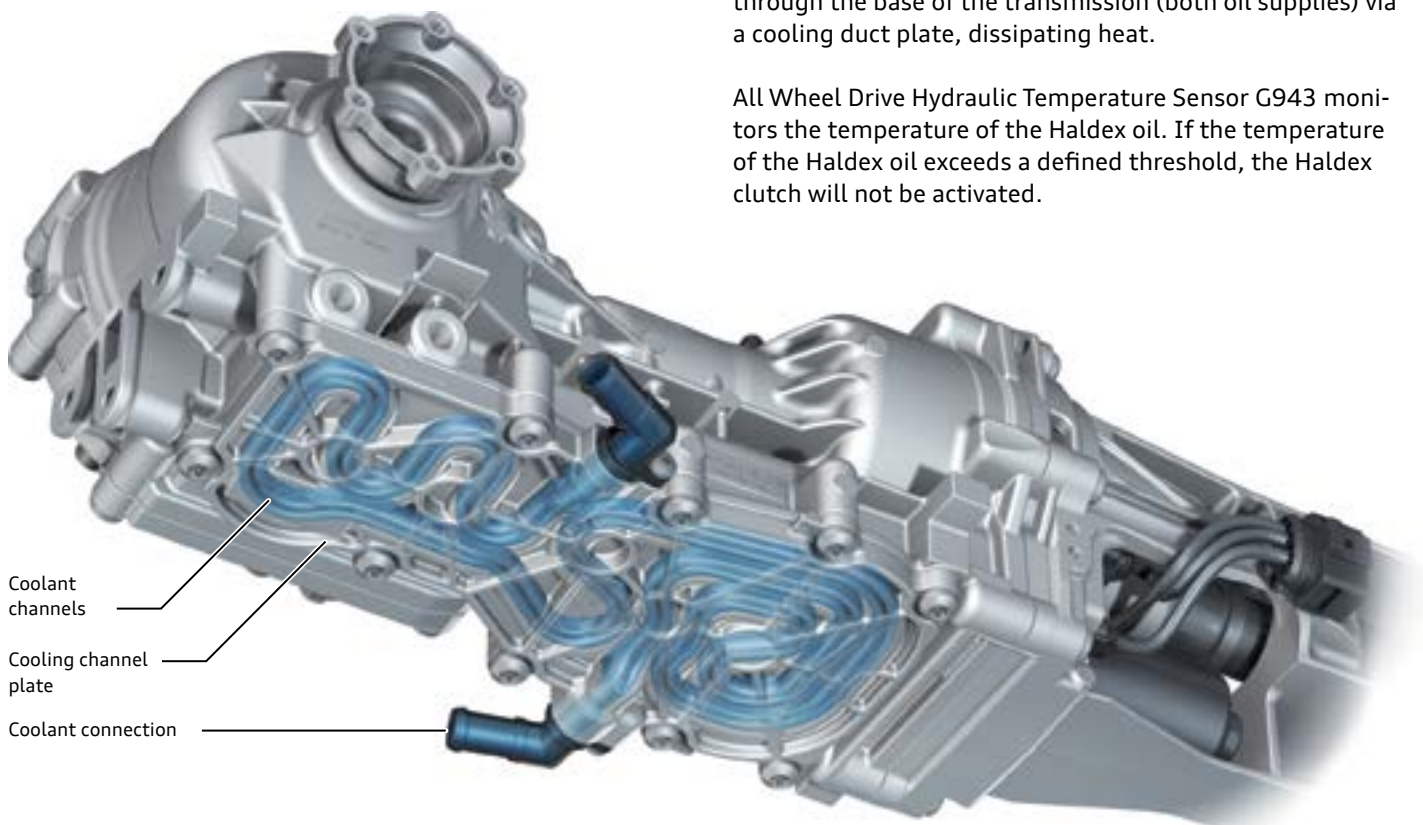

641\_065

## Component overview

The mode of operation and the hydraulic control parameters of final drive OD4 are largely identical to those of the 5th generation Haldex clutch.

The key function of the all-wheel drive clutch in the Audi R8 is to control and improve driving dynamics.

To allow better clutch control, the clutch is equipped with a pressure sensor as well as a temperature sensor.

Because the clutch mainly limits torque by slipping, higher demands are placed on clutch lubrication and cooling (refer to page 59). To meet these requirements, the multi-plate clutch has a separate, mechanical-powered oil pump. This oil pump is driven by the input shaft and continuously conveys a volume of oil dependent on the speed of the vehicle. This volume of oil ensures that the clutch is continuously lubricated and cooled.

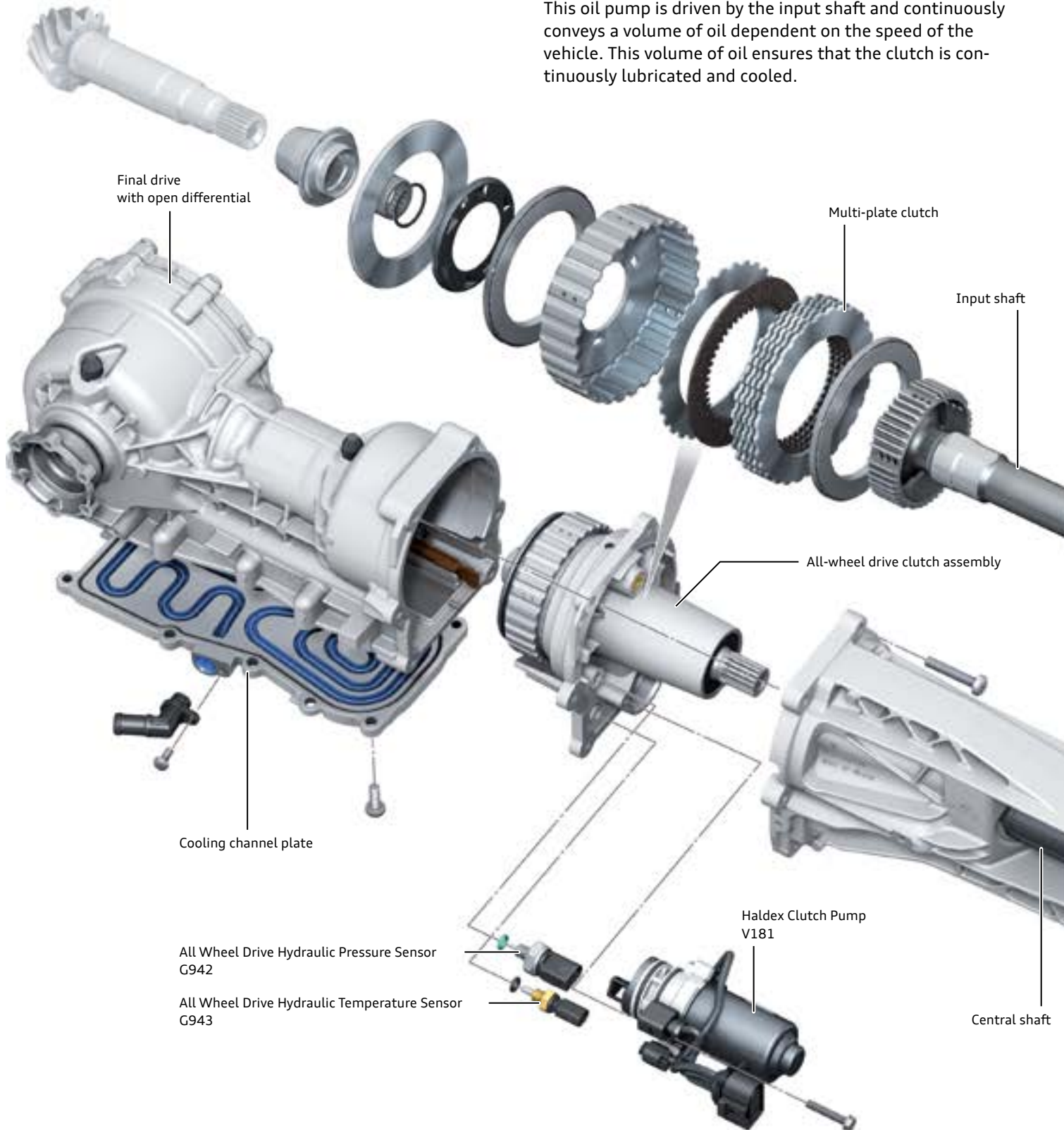

### Reference

For further information about the front final drive OD4, refer to [eSelf-Study Program 950163, Final Drive OD4](#).



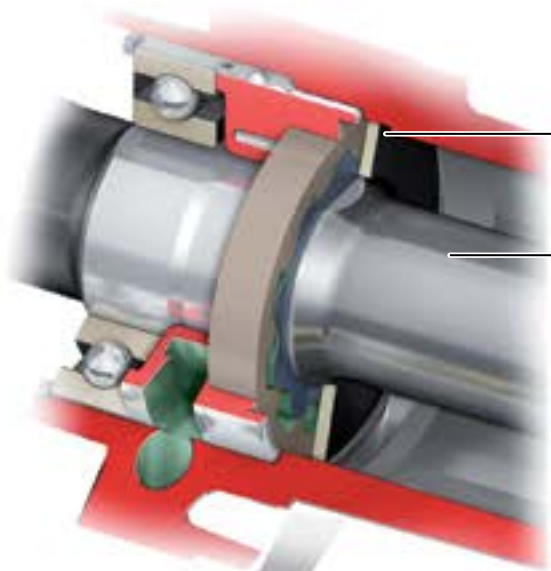

Mechanical oil pump

Input shaft

### Installing the propeller shaft

The propeller shaft transmits the drive torque to the central shaft by means of a spline. A bellows prevents the ingress of dirt and moisture into the spline.

The bellows must be installed as shown below. Follow all installation instructions given in ElsaPro.

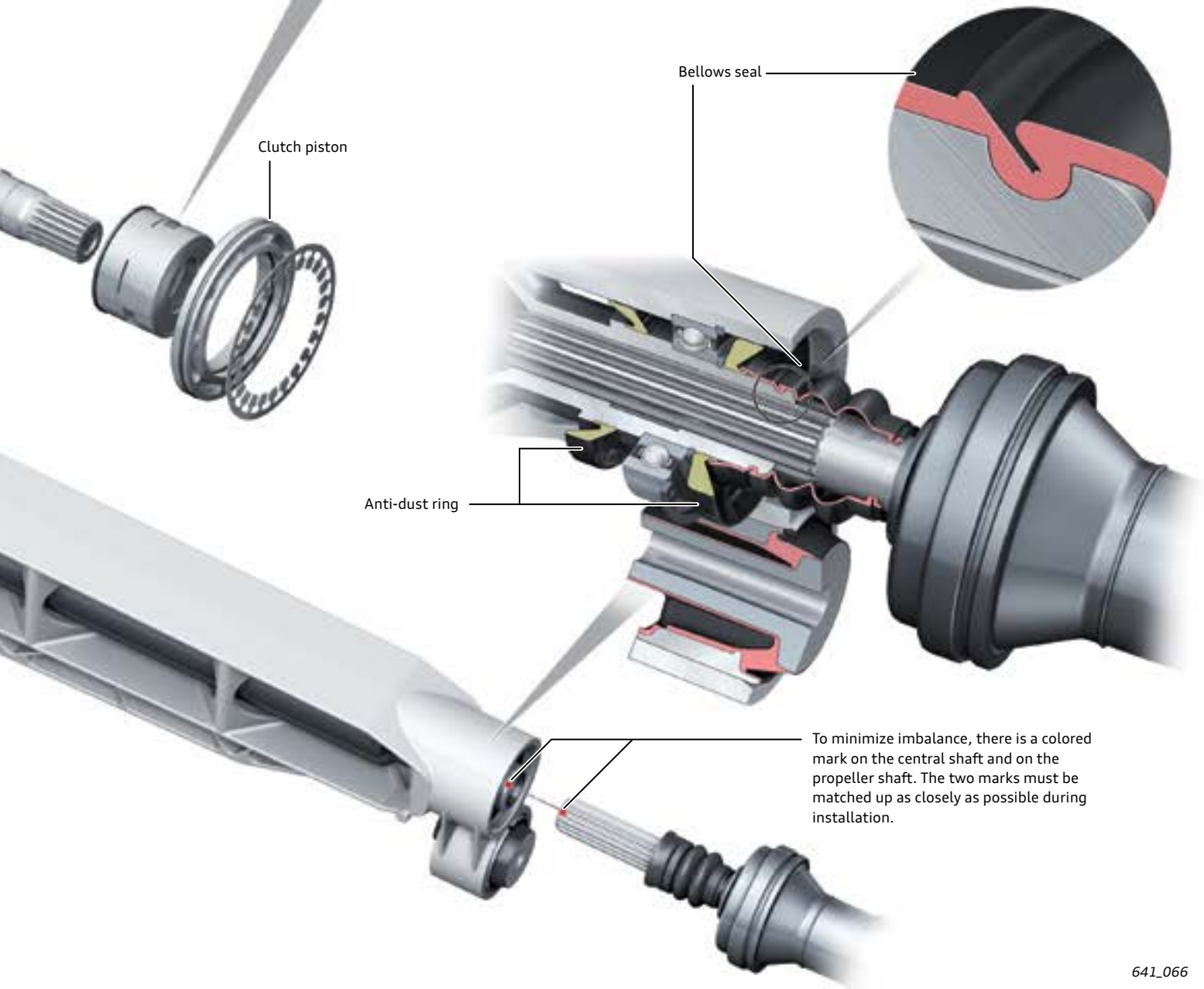

Clutch piston

Bellows seal

Anti-dust ring

To minimize imbalance, there is a colored mark on the central shaft and on the propeller shaft. The two marks must be matched up as closely as possible during installation.

## All Wheel Drive Control Module J492

J492 has driving dynamics software which calculates and provides the hydraulic pressure required for the all-wheel drive clutch depending on the driving situation and the selected Audi drive select mode. The software utilizes extensive information about the current status of the vehicle from other control modules such as the ABS/ESC Control Module, the ECM and the Transmission Control Module. Data is exchanged across the CAN bus networks.

The all-wheel drive clutch system uses an oil pressure sensor and an oil temperature sensor.

- › All Wheel Drive Hydraulic Pressure Sensor G942.
- › All Wheel Drive Hydraulic Temperature Sensor G943.

Both sensors allow for very precise all-wheel drive control and provide additional diagnostic options and component protection.

J492 is located behind the luggage compartment tray next to the vehicle battery.

- › Address Word 22.
- › Chassis CAN user.
- › A control module is available for both engine versions. The basic software is adapted at the factory based on engine power parameters. In addition, the control module and recorded learned values are assigned to the vehicle.
- › If the control module is to be replaced, the instructions given by the "replace control unit" Test Plan of the VAS Scan Tool must be followed:
  - › The learned values from the old control module are read out.
  - › The basic software of the new control module is supplied with the performance-specific parameters.
  - › The learned values of the old control module are transferred.
- › The vehicle identification number, performance-specific parameters and learned values are deleted using the "basic setting" Test Plan.



641\_067



### Note

Always follow the instructions and procedures as given in ElsaPro and the VAS Scan Tool when carrying out repairs, when replacing the control module, when replacing the final drive and when carrying out maintenance work.

### Limp-home concept

The all-wheel drive system initiates different limp-home programs depending on the nature of the fault.

- › If certain signals cannot be recorded, the driving dynamics control system may not be fully functional. In this case, the all-wheel drive clutch is only activated to a limited degree in order to improve traction.
- › In the event of serious faults, the all-wheel drive system is deactivated.
- › If a defined temperature value is exceeded under very high power demand, the all-wheel drive system will no longer be activated.

In all cases, warnings are displayed in the DIS to alert the driver.

### Warning lights



If the yellow warning light appears in the instrument cluster, it is normally possible to continue driving the vehicle. Information is displayed informing the driver what to do.



If the red warning light appears in the instrument cluster, the driver is instructed to stop the vehicle.

For detailed and up-to-date information, please refer to the vehicle Owner's Manual.

# Audi drive select – all-wheel drive configurations

Audi drive select allows the driver to choose from various all wheel drive clutch setups. This means the driver has the opportunity to experience driving dynamics in different ways.



641\_068

Audi drive select button

Performance button with adjusting ring for selecting the **snow**, **wet** and **dry** modes

## All-wheel drive configurations available with Audi drive select

### comfort / auto

The **comfort** and **auto** modes are identical in terms of the all-wheel drive setup. Driving behavior is balanced, that is, when the vehicle is operating at its dynamic limits it exhibits a neutral response with a slight tendency towards understeer in corners.

### dynamic

In **dynamic** mode driving behavior is sportier and more rear-biased than in **comfort** and **auto** modes. When the vehicle is operating at its dynamic limits, it exhibits a neutral response with a slight tendency towards oversteer.

### Performance

**Performance** mode offers super sporty driving dynamics, which can best be experienced on the race track. The all-wheel drive setup in this mode is configured for impressive driving experience and quick lap times.

In performance mode, the driver can adapt the vehicle setup and the all-wheel drive setup to three different road friction coefficients using the adjustment ring. When performance mode is activated, the last activated setup (**last mode**) is used by default.

<b>snow</b>	For very low friction coefficients, for example, on snow-covered roads.
<b>wet</b>	For reduced friction coefficients, for example, on wet (asphalt) roads.
<b>dry</b>	For high friction coefficients, for example, on dry (asphalt) roads.

The all-wheel drive control module constantly calculates the friction coefficients of the road surface. It is adapted continuously on the basis of this information. In the "friction modes" **snow**, **wet** and **dry** friction coefficients stored in the module are used to calculate pre-control values. The all-wheel drive control module is therefore able to react more quickly and with greater precision.



#### Note

Please note that the stabilization functions of the ESC and TSC systems are limited after activating performance mode. You should only activate performance mode if you have the necessary driving skills and the traffic conditions permit.

## Towing

The vehicle may be towed with both axles on the ground. It is not permitted to tow the vehicle with the front axle raised. This would result in damage to the final drive. Maximum towing distance is 31 mi (50 km).

Maximum towing speed is 31 mph (50 km/h). Of course, flatbed towing is preferred. Please refer to the Owner's Manual for more information.

# Chassis

## Overall concept



641\_179

The following suspension variants are available for the Audi R8

Suspension variants	Features
Sports suspension (1BV) <sup>1)</sup>	Sports suspension is standard on the R8 V10 plus. Models with sports suspension have an even sportier setup than the already sporty basic suspension. This is achieved by using different dampers and anti-roll bars.
Suspension with electronic damper control (2MN) <sup>1)</sup> V10 only	This suspension standard equipment on the R8 V10. It is based in the Audi Magnetic Ride system currently featured on other Audi models.

<sup>1)</sup> R8 V10 plus only.

# Axles and wheel alignment

## Front axle (R8 V10 plus)

The Audi R8 also employs the double wishbone axle concept which proved highly effective in the predecessor model.

### Ball joints

- > Integrated in the wishbones as a wishbone/pivot bearing connection

### Spring

- > Steel spring with linear characteristic

### Damper

- > Twin-tube damper with additional polyurethane spring
- > Aluminum housing with forged aluminum fork joined by friction welding

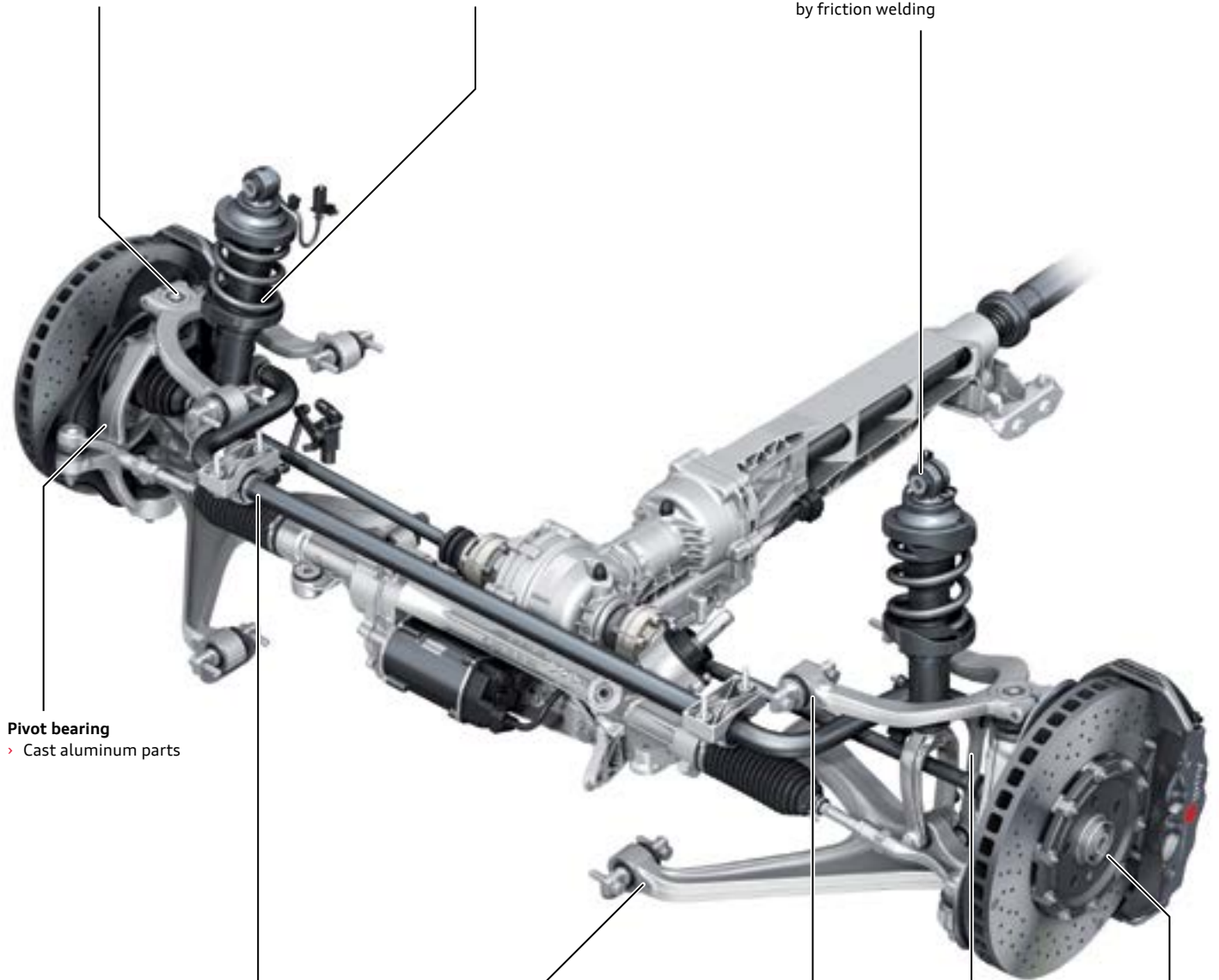

### Pivot bearing

- > Cast aluminum parts

### Anti-roll bar

- > Tubular anti-roll bars
- > Mounted in slotted rubber bearings (replaceable)

### Lower wishbone

- > Forged aluminum parts

### Upper wishbone

- > Forged aluminum parts

### Tie rod

- > Aluminum forgings with press-fit rubber-metal bearings

### Wheel bearing/wheel hub

- > Second generation wheel bearing
- > Wheel hub is separate part

## Rear axle (R8 V10 plus)

The Audi R8 uses the double wishbone axle concept which proved highly effective in the predecessor model.

### Ball joints

- > As a wishbone/wheel carrier connection integrated in the upper wishbones and in the lower wheel carriers

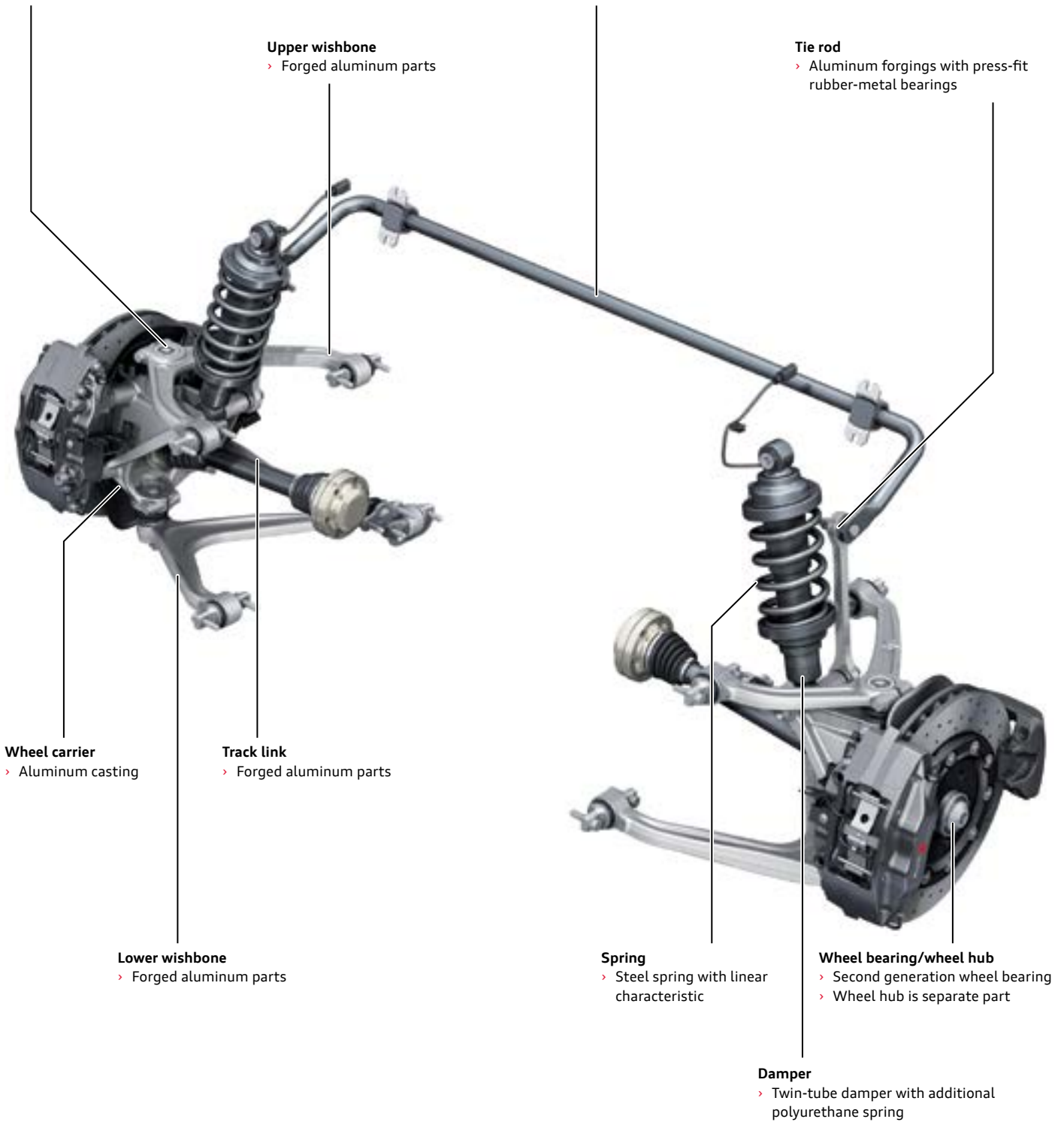

## Wheel alignment and suspension setup

The left and right toe values on the front axle can be adjusted separately by altering the length of the tie rods. The individual toe values on the rear axle are also set at the tie rods.

There is a new procedure for setting camber on the front and rear axles. Separate shim plates are inserted between the contact faces of the lower wishbones and the body. Shim plates are used on the front axle at each of the front and rear attachment points.

Shim plates are only used at the rear mounting points connecting the lower wishbone to the body on the rear axle.

The shim plates are available in various thicknesses (1, 2 and 3 mm). It is important that the same dimensions are set at the two lower wishbone attachment points on the front axle. In general, up to 2 shim plates can be used per attachment point.

### Camber adjustment on the front axle (R8 V10 and R8 V10 plus)

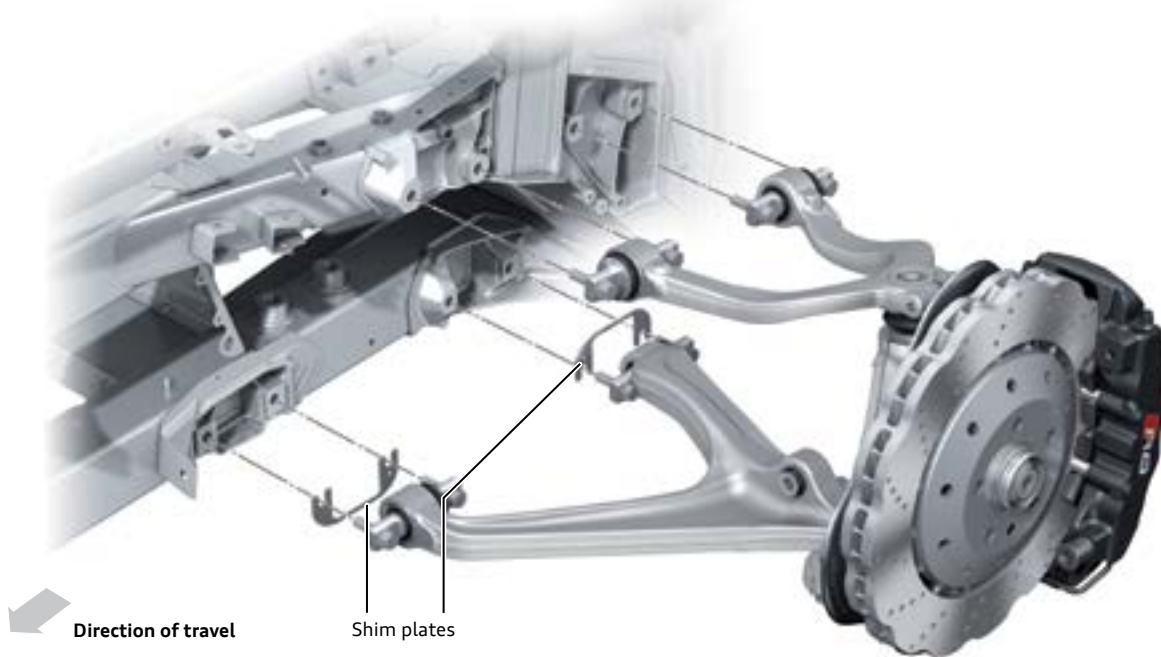

641\_177

### Camber adjustment on the rear axle (R8 V10 and R8 V10 plus)

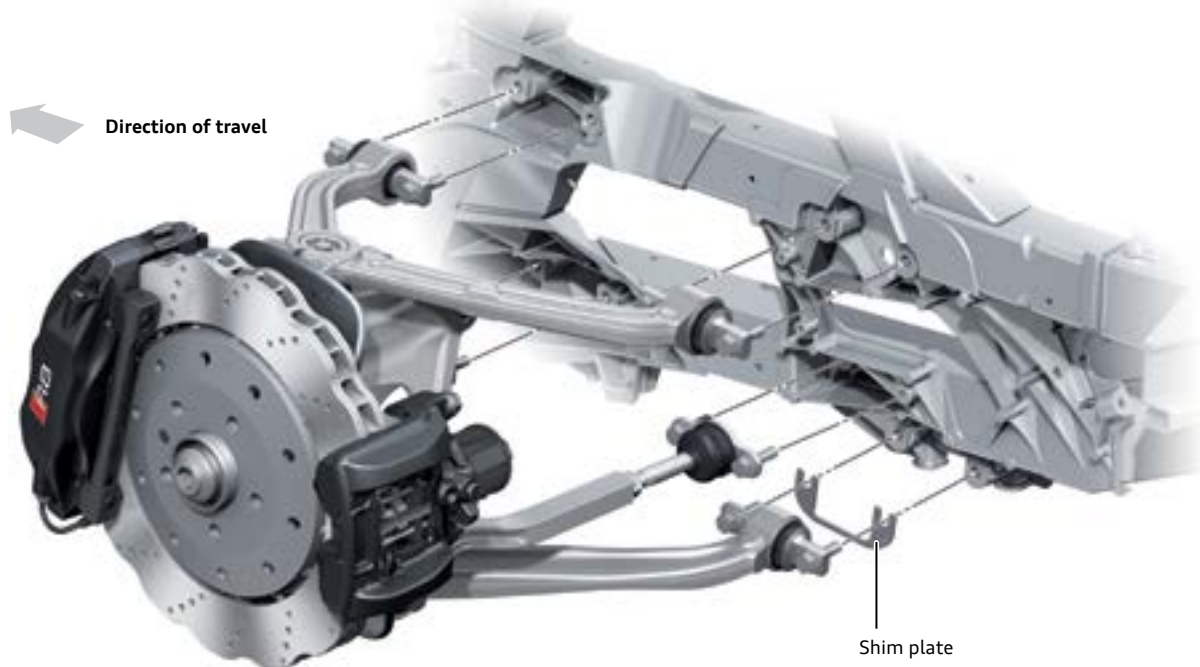

641\_178

## Suspension with electronic damper control (2MN)

The electronic damper control (standard on the V10 R8) is based in the Audi magnetic ride system currently available in other Audi models. Electronic Damping Control Module J250 is located at the heel plate behind the front passenger seat.

Depending on the drive select setting, the damper control provides sporty (**dynamic**), comfortable (**comfort**) or balanced (**auto setting**) driving behavior. The service operations are identical to those of existing, established systems.

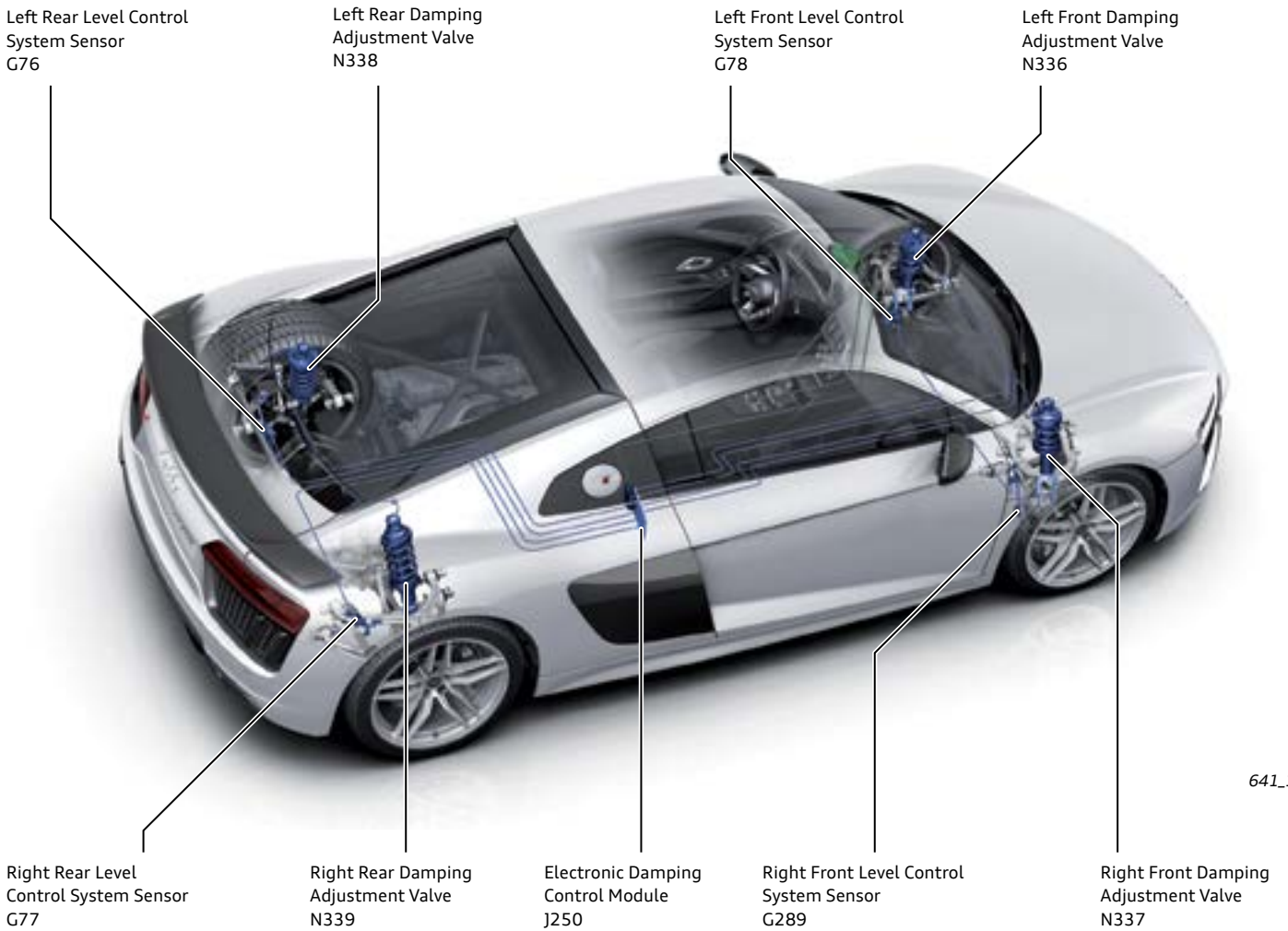

641\_180



# Brake system

## Brake system, front axle

	Conventional brake system (standard equipment for R8 V10)	Ceramic brake system (standard equipment for R8 V10 plus, optional for R8 V10)
Minimum wheel size	18"	19"
Brake type	Brembo fixed caliper brake	Brembo fixed caliper brake
Number of pistons	8	6
Brake disc diameter	14.4 in (365 mm)	14.9 in (380 mm)
Brake disc thickness	1.3 in (34 mm)	1.5 in (38 mm)



Conventional 18" brake system

641\_182



19" ceramic brake system

641\_183

## Brake system, rear axle

An electro-mechanical parking brake (EPB) is used in the Audi R8 for the first time.

	Conventional brake system (standard equipment for R8 V10)	Ceramic brake system (standard equipment for R8 V10 plus, optional for R8 V10)
Minimum wheel size	18"	19"
Brake type	Brembo fixed caliper brake	Brembo fixed caliper brake
Number of pistons	4	4
Brake disc diameter	14.0 in (356 mm)	14.0 in (356 mm)
Brake disc thickness	1.3 in (32 mm)	1.3 in (32 mm)



Conventional rear brake system with EPB as standard equipment

641\_184

## Electro-mechanical parking brake (EPB)

A key new feature of the Audi R8 is the electro-mechanical parking brake. The EPB actuator combines with the brake linings and the housing to form a separate floating caliper. In terms of design, function, operation and scope of service, the actuator is identical to the actuator used in the 2016 Audi A7 Sportback.



641\_185

Electro-mechanical parking brake (EPB)

## Brake servo, master brake cylinder, pedal assembly

Two brake servo variants with different ratios are available depending on the wheel brake used: conventional brake system or ceramic brake system.

The tandem master brake cylinder is a new development. The brake fluid reservoir is a carryover from the previous Audi R8. The brake servo is a carryover from the Audi A7 Sportback.

The pedal assembly is a new development.



641\_186



641\_187

## Electronic Stability Control (ESC)

### Overview

The 2017 R8 uses Bosch ESC 9.0. This system was introduced on the 2016 Audi A7 Sportback and has been adapted for the R8. The module is located on the right hand side of the vehicle in the luggage compartment.

The ESC system uses measurement data from Sensor Electronics Control Module J849 and features active wheel speed sensors as used on other Audi models.



641\_188

### Operation

A two stage operating concept was implemented for the R8. Sport mode is activated by briefly pressing the ESC button for less than three seconds. The TCS and ESC stabilization functions are then restricted to allow an even more sporty driving style. If the ESC button is pressed for longer than three seconds, TCS and ESC will be fully deactivated.



641\_189

ESC-OFF button

A key new feature is the performance mode, which can be activated with a separate operating button on the multi-function steering wheel.

Depending on the ambient conditions and the resultant friction between the tires and road surface (**dry**, **snow** and **wet** settings), the vehicle's handling characteristics and dynamics can be adapted accordingly. In this connection, the control response of the ESC system is also varied.

If one of these settings is selected, the overriding ESC operating logic explained above remains unaffected. Even if performance mode is activated, the driver can select between full TSC and ESC functionality, sport mode or OFF.



641\_190

Performance button with adjusting ring for selecting the **snow**, **wet** and **dry** modes



### Reference

For detailed information about the design, function and service operations, refer to [eSelf-Study Program 990303, The 2012 Audi A7 Running Gear and Suspension Systems](#).

# Steering system

## Overview

The Audi R8 now also has electro-mechanical steering. Dynamic steering is optional. The mechanically adjustable steering column is a new development. It is a steel construction with an aluminum steering shaft and is attached to the module cross-member. The steering has axial and vertical adjustment ranges of 2.4 in (60 mm) and 2.0 in (50 mm) respectively. If the vehicle is equipped with the optional dynamic steering system, a specially configured connection system is used.

Two newly developed multi-function steering wheels with a sporty 3-spoke design are used.



641\_191

## Electro-mechanical power steering (EPS)

Basically, the paraxial electro-mechanical steering system is identical in design to the steering system used in the current A3, TT, and Q3 models, as well as in the Lamborghini Huracán. Unlike the steering system in the above-mentioned models, the steering angle sender in the Audi R8 is not integrated in the steering gear but rather in the steering column switch module.

Whereas the electro-mechanical steering system on the 2015 A3, 2016 TT and 2015 Q3 models provides steering assistance through a second steering pinion driven by an electric motor, the electro-mechanical steering system in the Audi R8 transmits power to the steering rack through a ball screw.

In functional terms, this steering system is identical to the steering system used on the 2016 A6, 2016 A7 Sportback, A8 and 2017 Q7 models. The difference between the Audi R8 and these models is that the ball nut on the Audi R8 is driven through a belt drive by an electric motor aligned in parallel with the steering rack.

On the A6, A7 Sportback, A8 and Q7 models, the electric motor concentrically "encases" the steering rack. The paraxial layout was chosen for design space reasons in particular. Whereas the concentric layout involves making allowance for an installation height of about 4.7 in (120 mm), the installation height for the paraxial layout is only about 2.3 in (60 mm).

The service operations for the steering system in the Audi R8 are also identical to those for the steering system on the A6, A7 Sportback, A8 and Q7 models.

This steering system is operated by selecting the relevant mode in the Audi drive select handling system. Three maps have been programmed into the control unit for this purpose. A fourth map is utilized when performance mode is activated.



641\_192

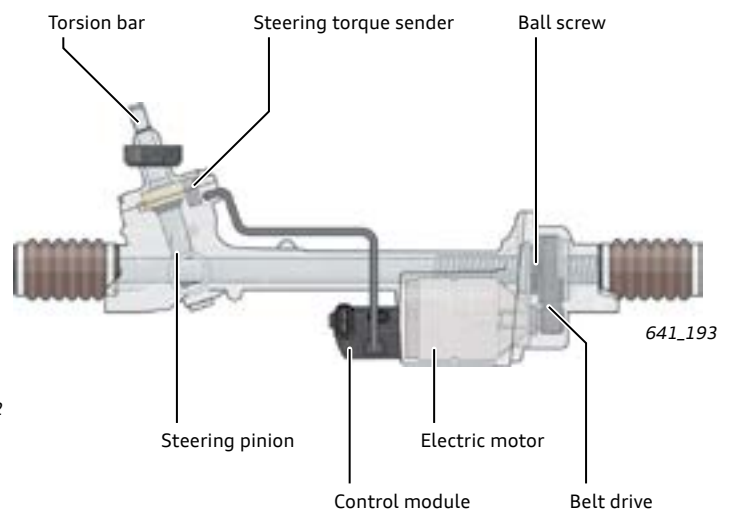

641\_193



### Reference

For detailed information about the steering system, refer to [eSelf-Study Program 990303, The 2012 Audi A7 Running Gear and Suspension Systems](#).

## Dynamic steering

Dynamic steering is optional for both the R8 V10 and R8 V10 plus. In terms of design, function and service operations, the system is identical to the system currently being used in other Audi models.

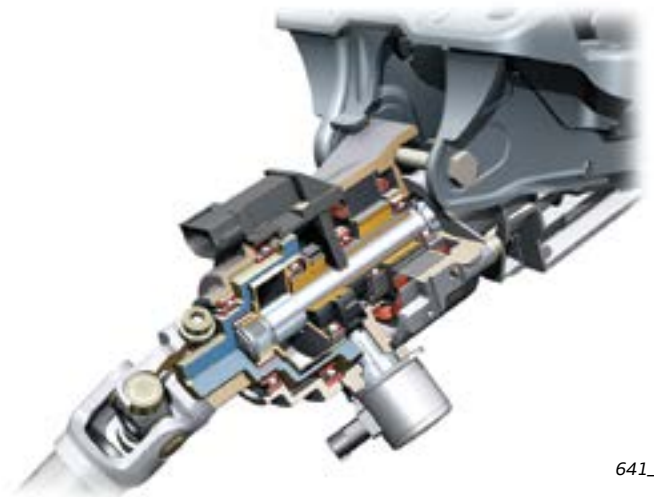

641\_194

## Steering wheels

### Audi R8 standard leather steering wheel

Two newly developed steering wheels are used.

The Audi R8 V10 is equipped with the sport leather steering wheel with multi-function plus and two operating satellites ("drive select" and "START ENGINE STOP").



641\_195

Audi drive select button

START ENGINE STOP button

### Audi R8 performance leather steering wheel

The performance leather steering wheel with multi-function plus and four operating satellites (additional buttons for engine sound and performance mode) is standard in the Audi R8 V10 plus.



641\_196

Audi drive select button

START ENGINE STOP button





Performance button with adjusting ring for selecting the snow, wet and dry modes

Engine sound button

## Wheels and tires

The Audi R8 comes as standard with 19" wheels. 19" and 20" wheels are optional. The range of summer tires extends from 245/35 R19 to 305/30 R20.

The "Tire Mobility System" is standard equipment.

Standard wheels	Optional wheels
 <p><b>Cast aluminum wheel</b></p> <p><b>Front axle:</b> 8.5J x 19 ET42 245/35 R19</p> <p><b>Rear axle:</b> 11.0J x 19 ET50 295/35 R19</p> <p>R8 V10</p>	 <p><b>Forged aluminum wheel</b></p> <p><b>Front axle:</b> 8.5J x 20 ET42 245/30 R20</p> <p><b>Rear axle:</b> 11.0J x 20 ET47 305/30 R20</p>
 <p><b>Forged aluminum wheel Titanium-matte finish</b></p> <p><b>Front axle:</b> 8.5J x 19 ET42 245/35 R19</p> <p><b>Rear axle:</b> 11.0J x 19 ET50 295/35 R19</p> <p>R8 V10 plus</p>	 <p><b>Forged aluminum wheel Titanium-matte finish</b></p> <p><b>Front axle:</b> 8.5J x 20 ET42 245/30 R20</p> <p><b>Rear axle:</b> 11.0J x 20 ET47 305/30 R20</p>

641\_197

## Tire pressure monitoring system (TPMS)

Tire pressure and temperature are measured at regular intervals by the tire pressure sensors integrated in the tire. The sensors communicate with the monitoring transmitters, which send the data to the control module, both while the vehicle is stationary and while driving. The sensors send data telemetrically via a HF transmission path to the receiver antenna integrated in the control module. The driver can view the pressure and temperature status of tires on the MMI monitor.

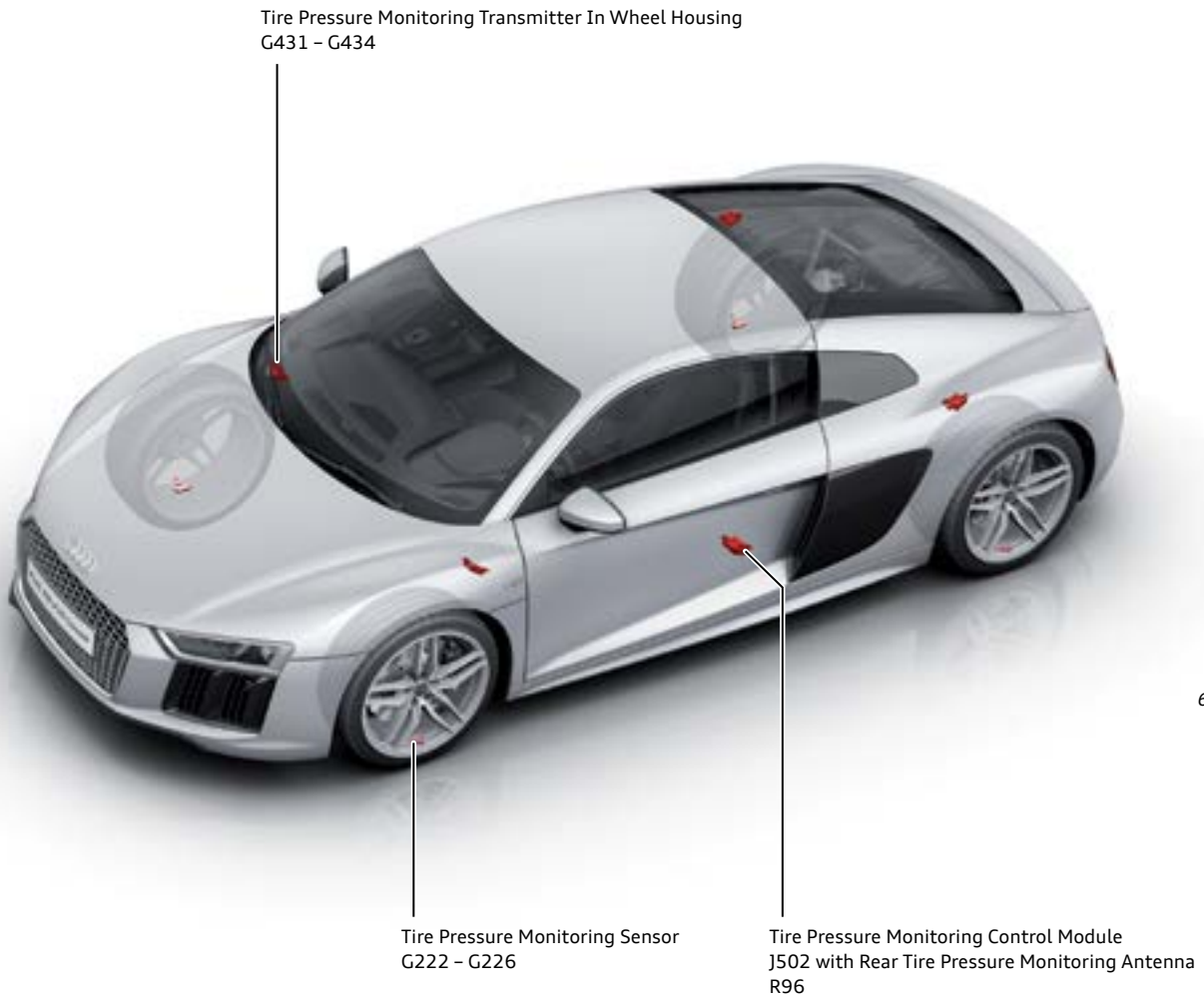

641\_198

# Knowledge assessment

An On-Line Knowledge Assessment (exam) is Available for this eSelf-Study Program.

The Knowledge Assessment is required for Certification credit.

You can find this Knowledge Assessment at:

[www.accessaudi.com](http://www.accessaudi.com)

From the [accessaudi.com](http://accessaudi.com) Homepage:

- ▶ Click on the “ACADEMY” tab
- ▶ Click on the “Academy site” link
- ▶ Click on the Course Catalog Search and select “990363 - The 2017 Audi R8 Introduction”

Please submit any questions or inquiries via the Academy CRC Online Support Form which is located under the “Support” tab or the “Contact Us” tab of the Academy CRC.

*Thank you for reading this eSelf-Study Program and taking the assessment.*





All rights reserved.  
Technical specifications are  
subject to change without notice.

Audi of America, LLC  
2200 Ferdinand Porsche Drive  
Herndon, VA 20171