

P-Town Auto & Offroad, LLC

688 Harshaw Ave.
Patagonia, AZ 85624
(520) 394-0181 T

YMMS: 2003 Nissan Maxima GXE

Engine: 3.5L Eng

VIN:

Jul 22, 2024

License:

Odometer:

ENGINE PERFORMANCE > 3.5L

Fig 1: 3.5L, Engine Performance Circuit (1 of 4)

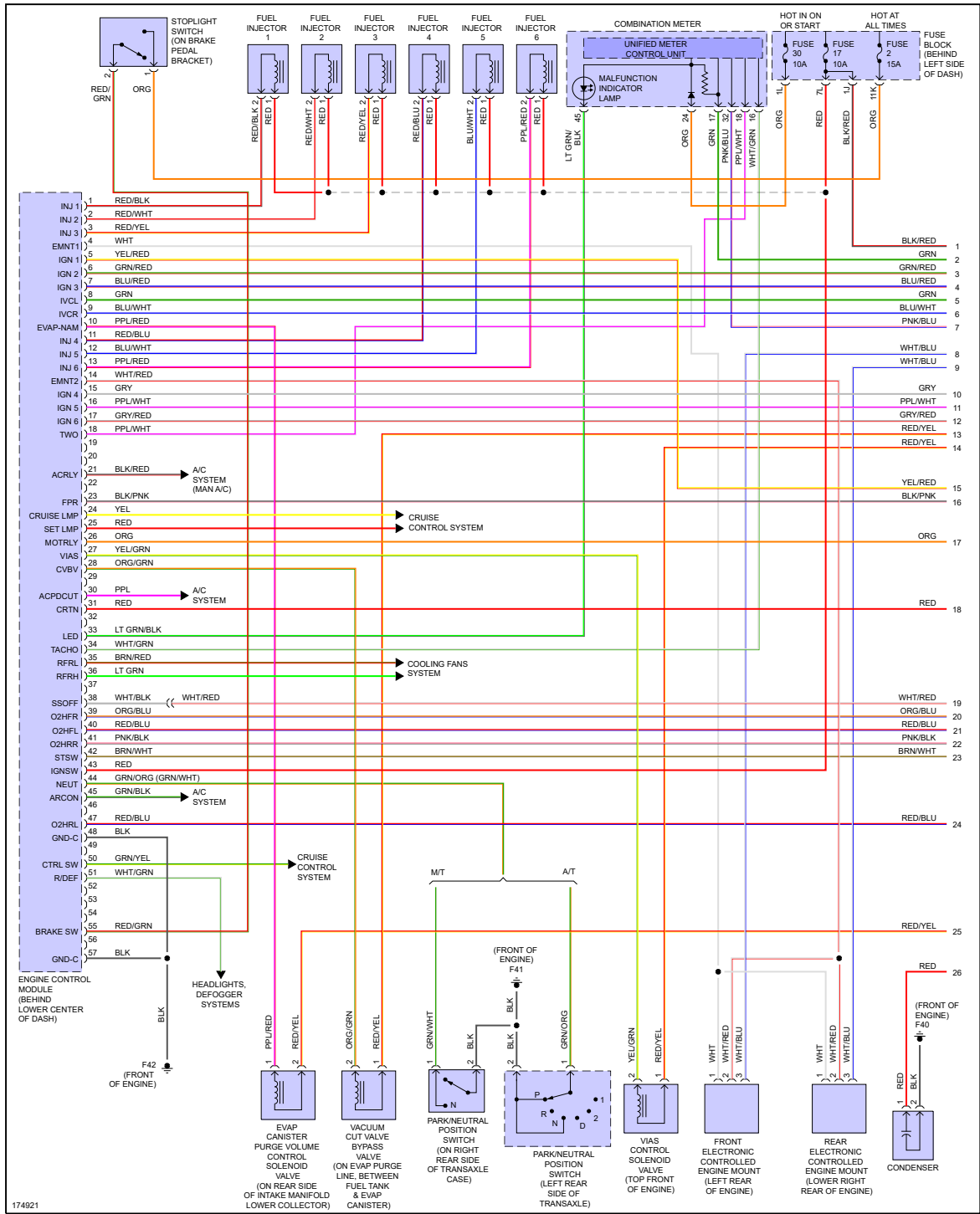

Fig 2: 3.5L, Engine Performance Circuit (2 of 4)

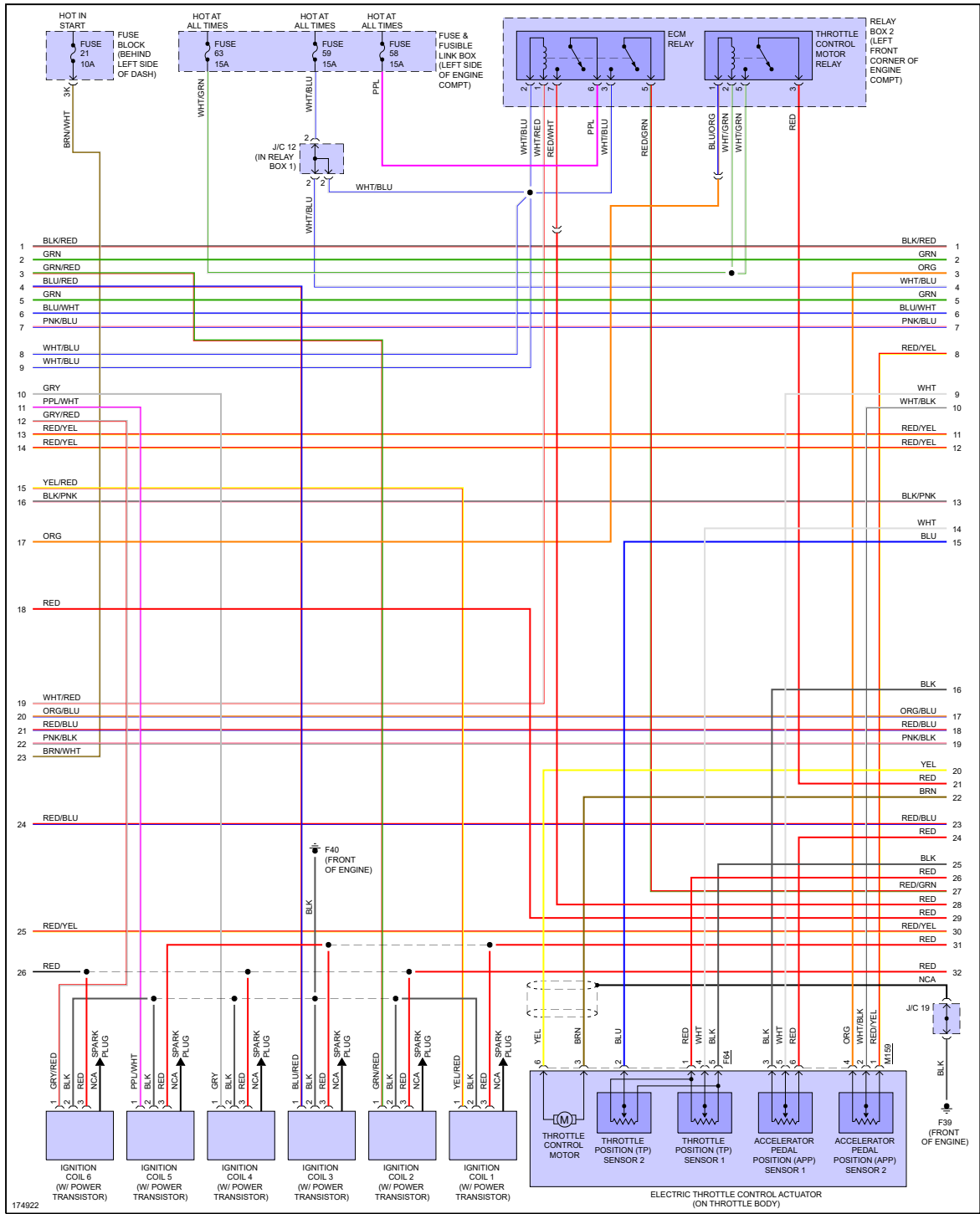

Fig 3: 3.5L, Engine Performance Circuit (3 of 4)

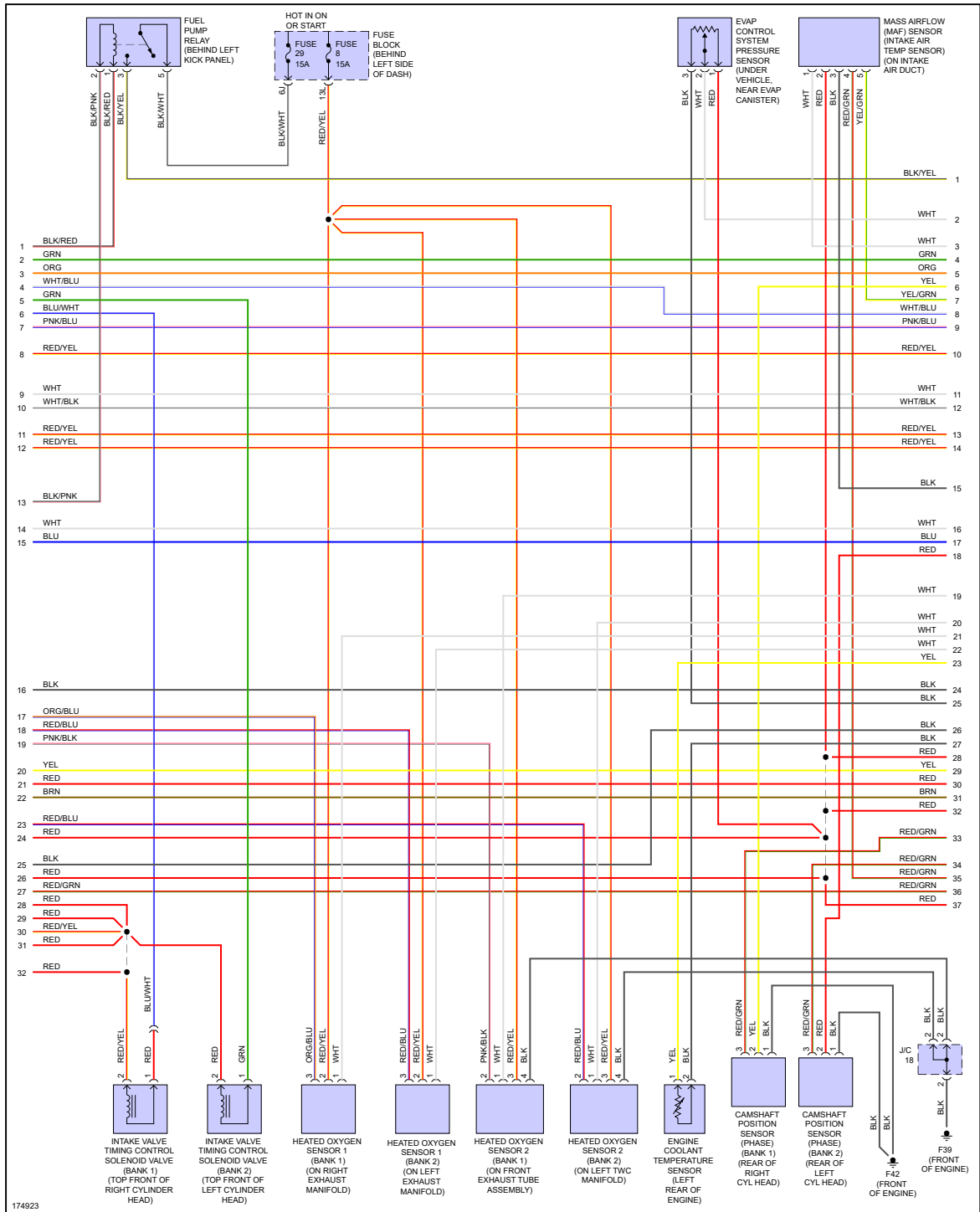
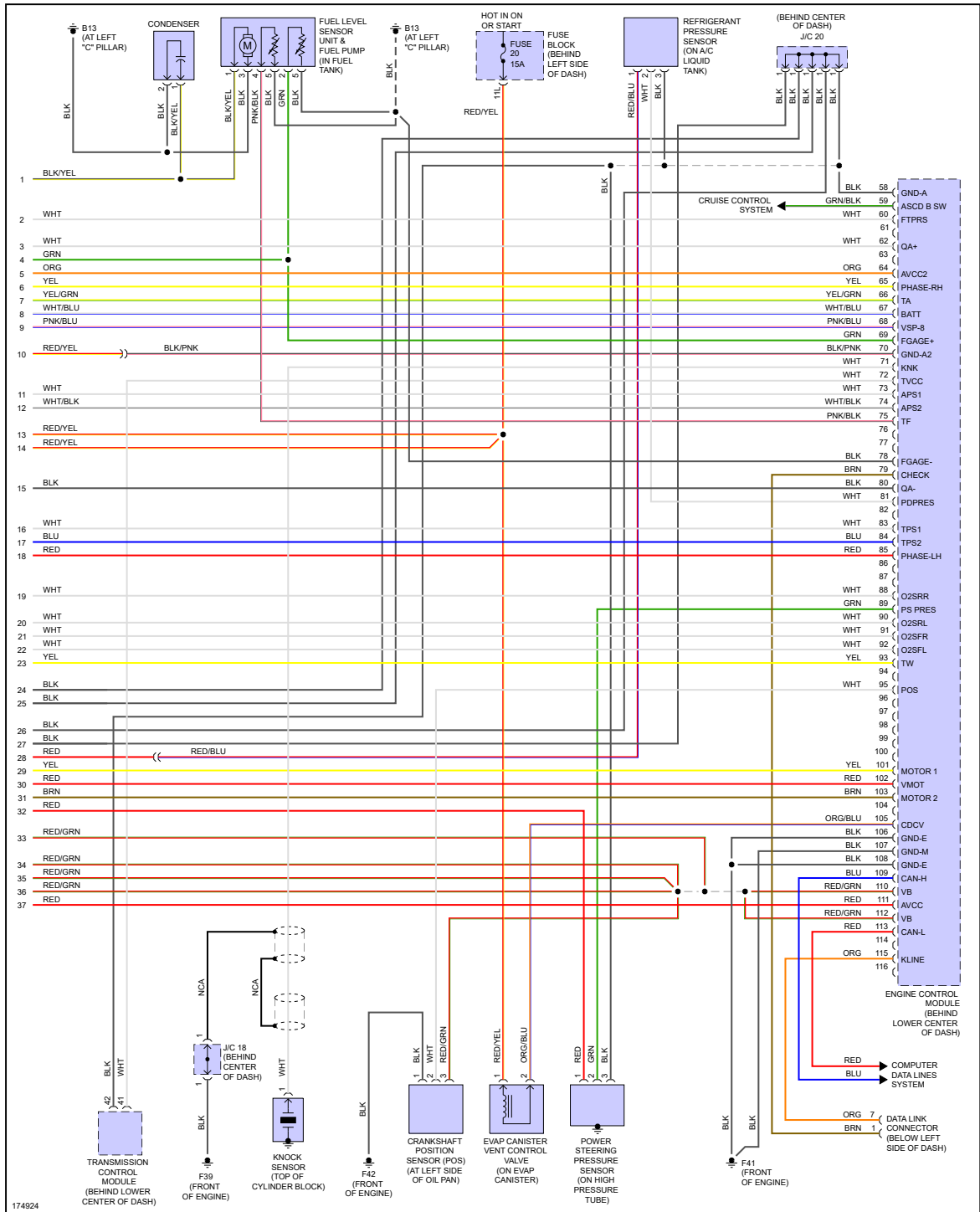

Fig 4: 3.5L, Engine Performance Circuit (4 of 4)



"If your car is beat down, bring it to P-Town!"