

P-Town Auto & Offroad, LLC

688 Harshaw Ave.
Patagonia, AZ 85624
(520) 394-0181 T

YMMS: 2011 Toyota Sienna LE
Engine: 3.5L Eng
VIN:

Apr 16, 2024

License:
Odometer:

TRANSMISSION > 2.7L

Fig 1: 2.7L, A/T Circuit (1 of 2)

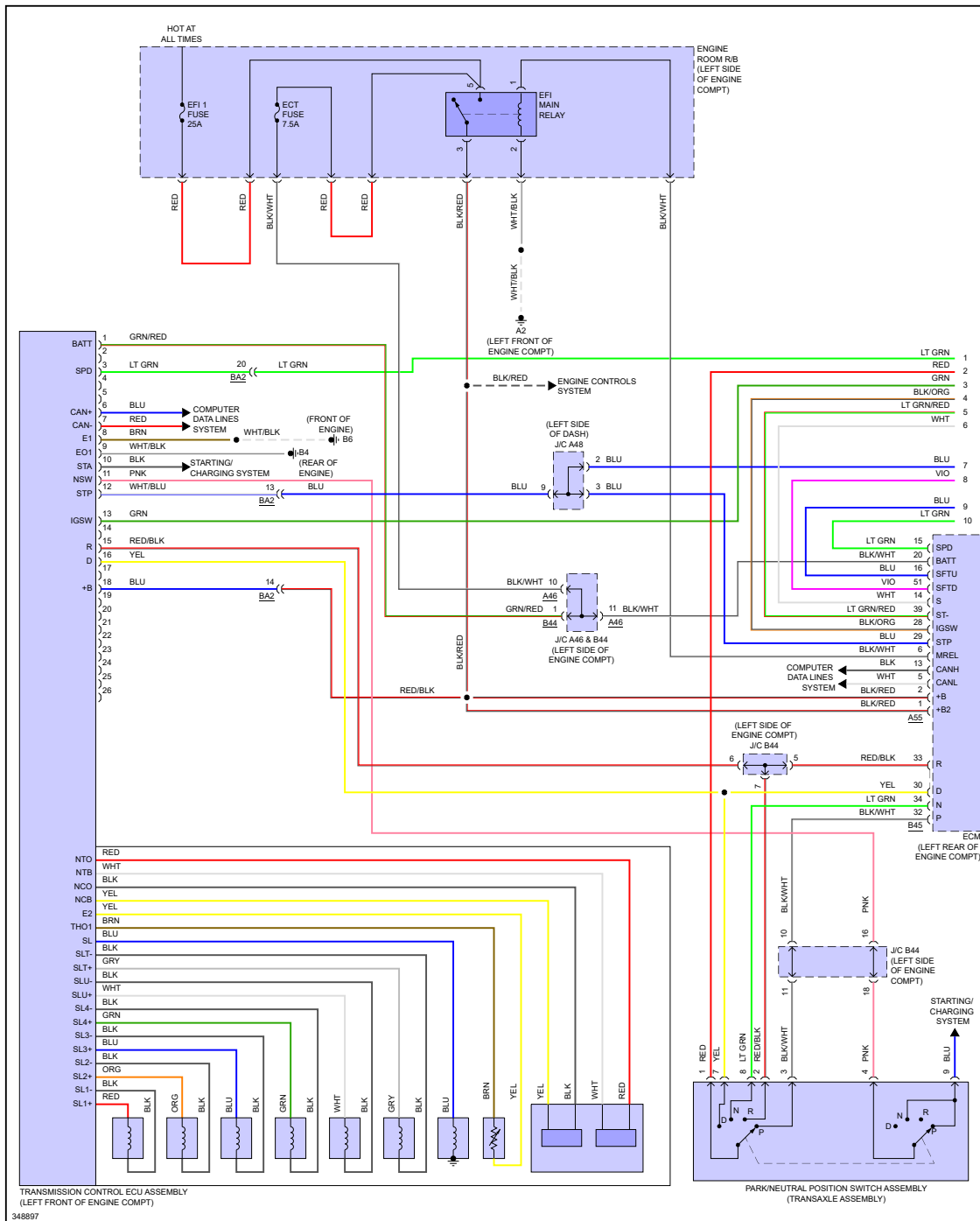

Fig 2: 2.7L, A/T Circuit (2 of 2)

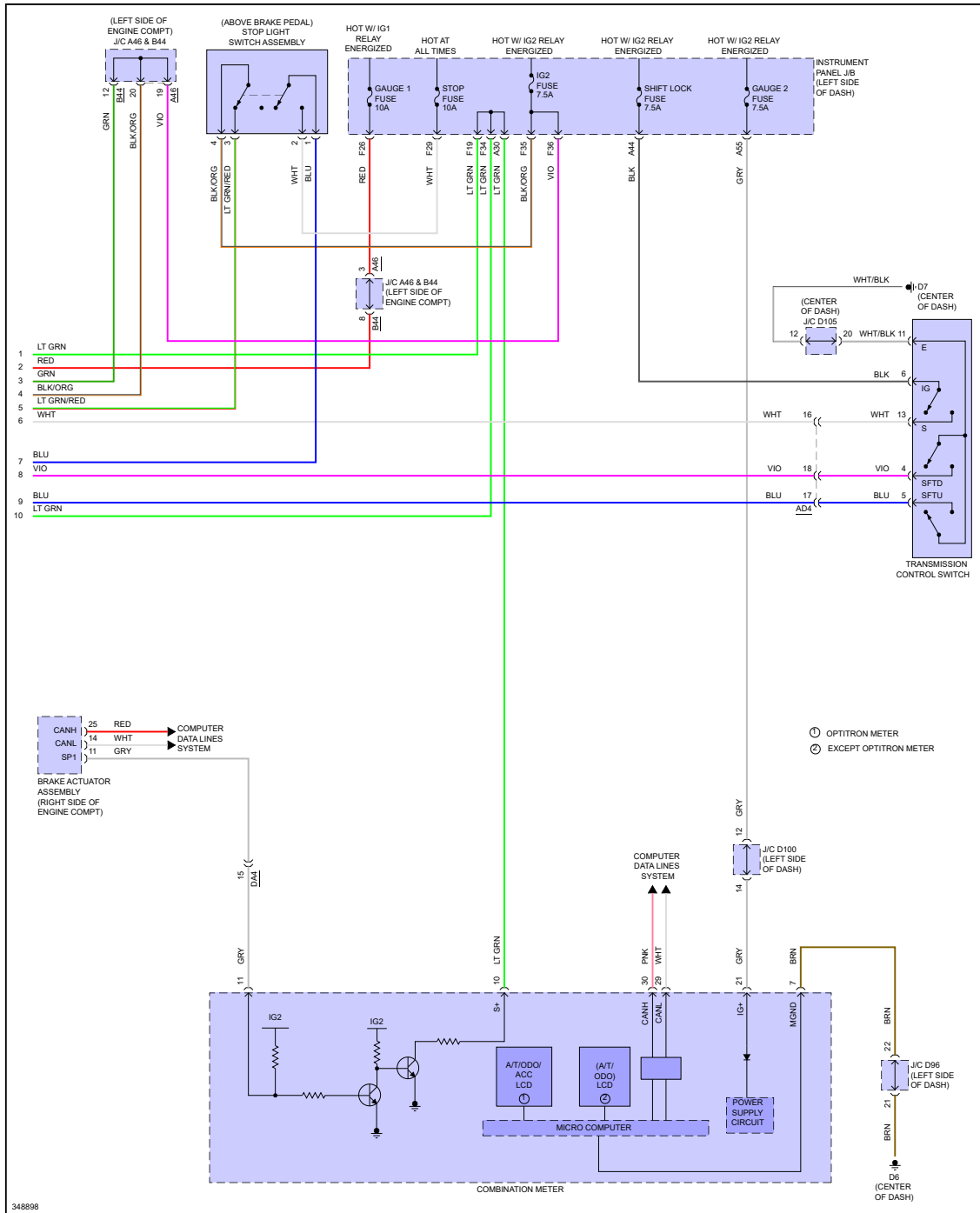
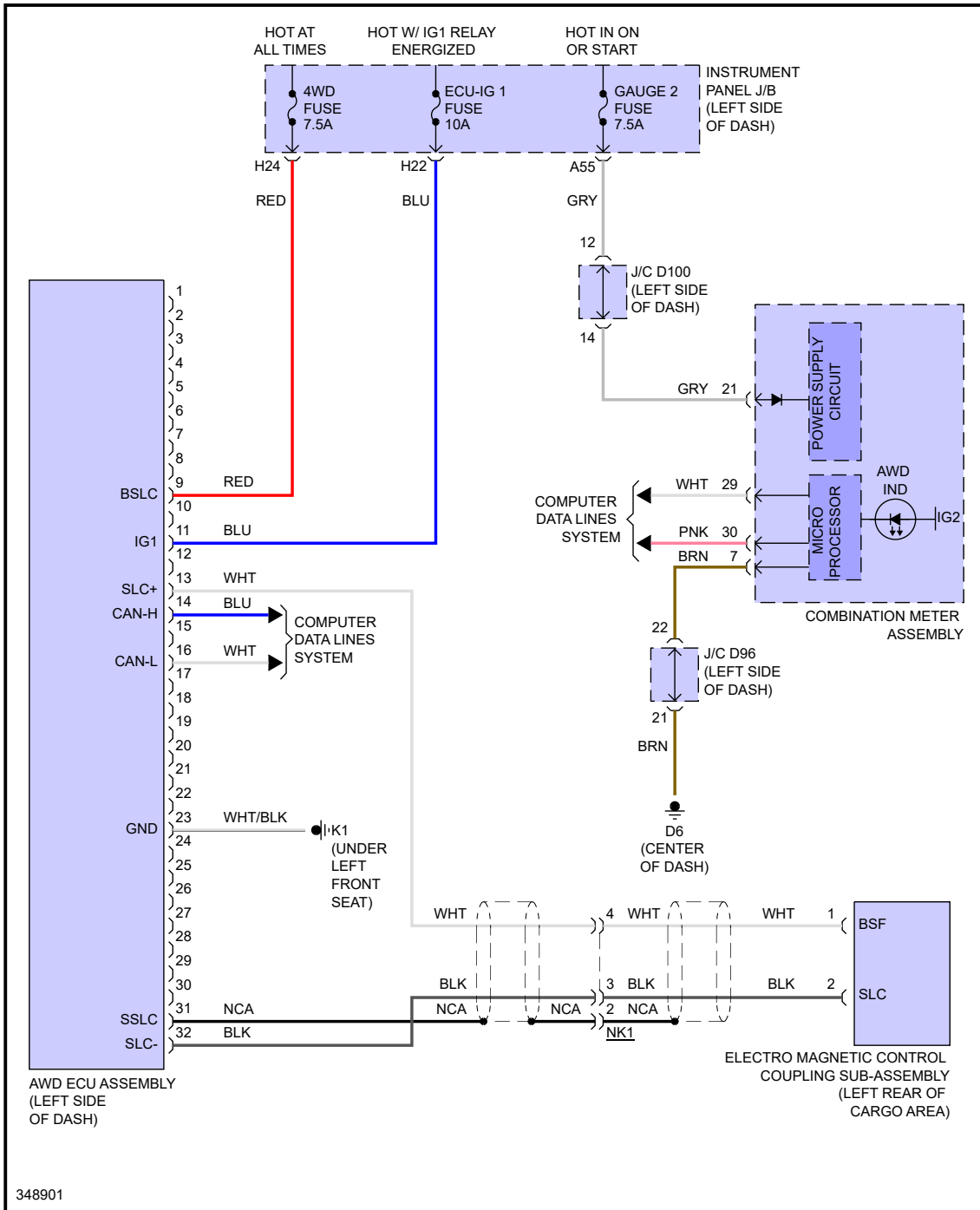

Fig 3: 2.7L, AWD Circuit



348901

"If your car is beat down, bring it to P-Town!"

Reprinted Under License from Toyota Motor Sales, U.S.A., Inc., License Agreement TMS1002