

# P-Town Auto & Offroad, LLC

688 Harshaw Ave.  
Patagonia, AZ 85624  
(520) 394-0181 T

YMMS: 2013 Nissan 370Z Nismo

Engine: 3.7L Eng

VIN:

Jun 8, 2024

License:

Odometer:

**ENGINE PERFORMANCE > 3.7L**

Fig 1: 3.7L, Engine Performance Circuit (1 of 5)

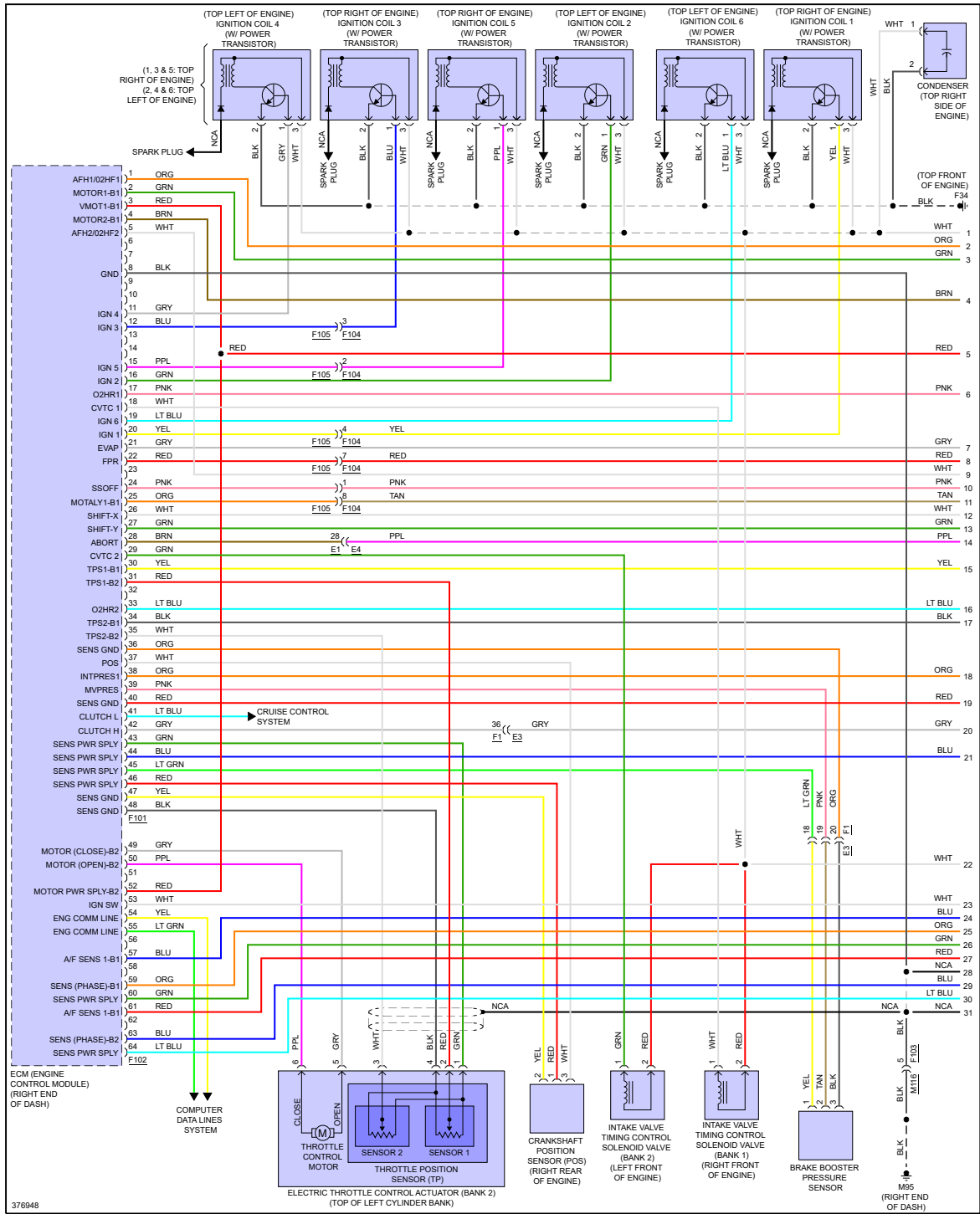

Fig 2: 3.7L, Engine Performance Circuit (2 of 5)

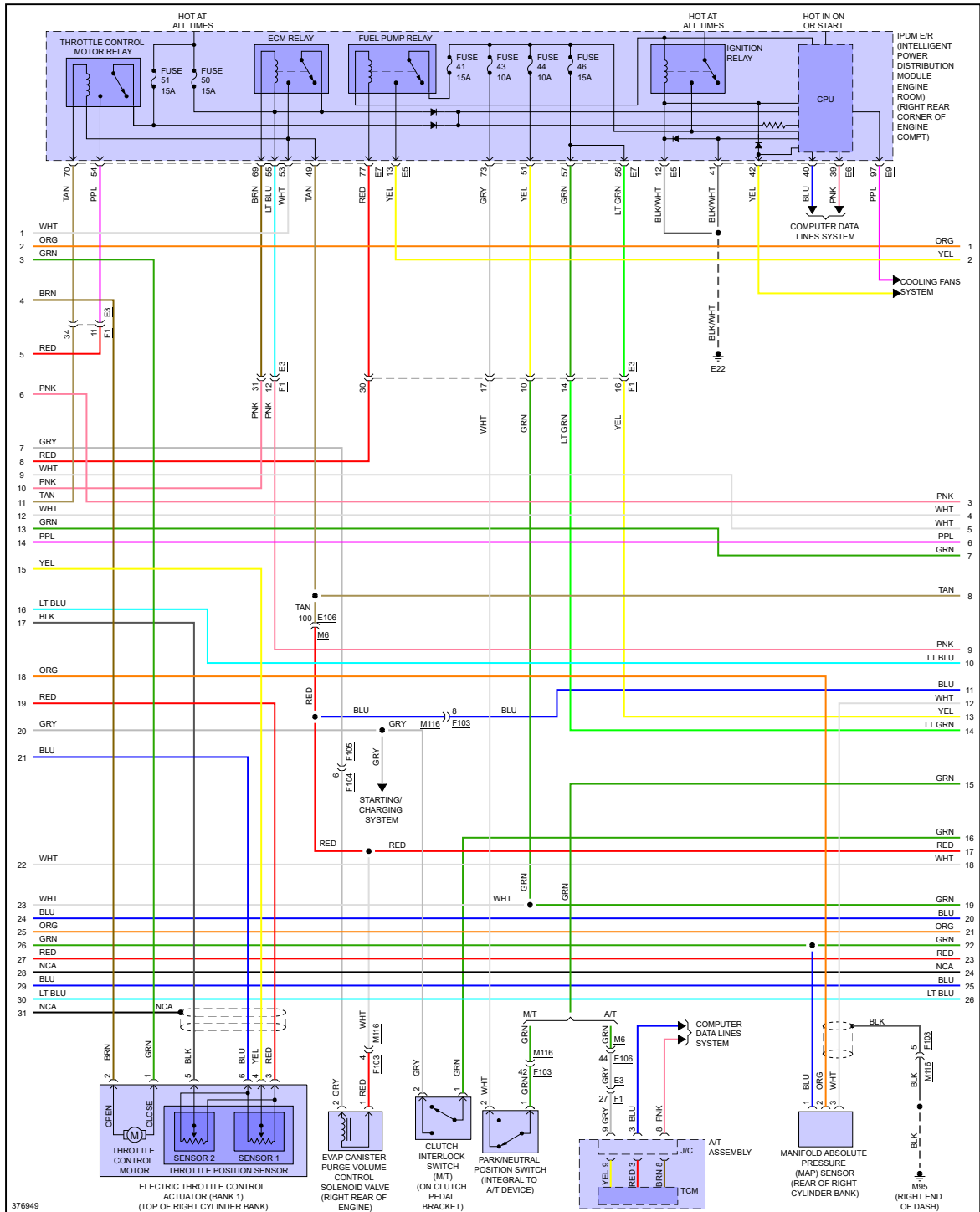

Fig 3: 3.7L, Engine Performance Circuit (3 of 5)

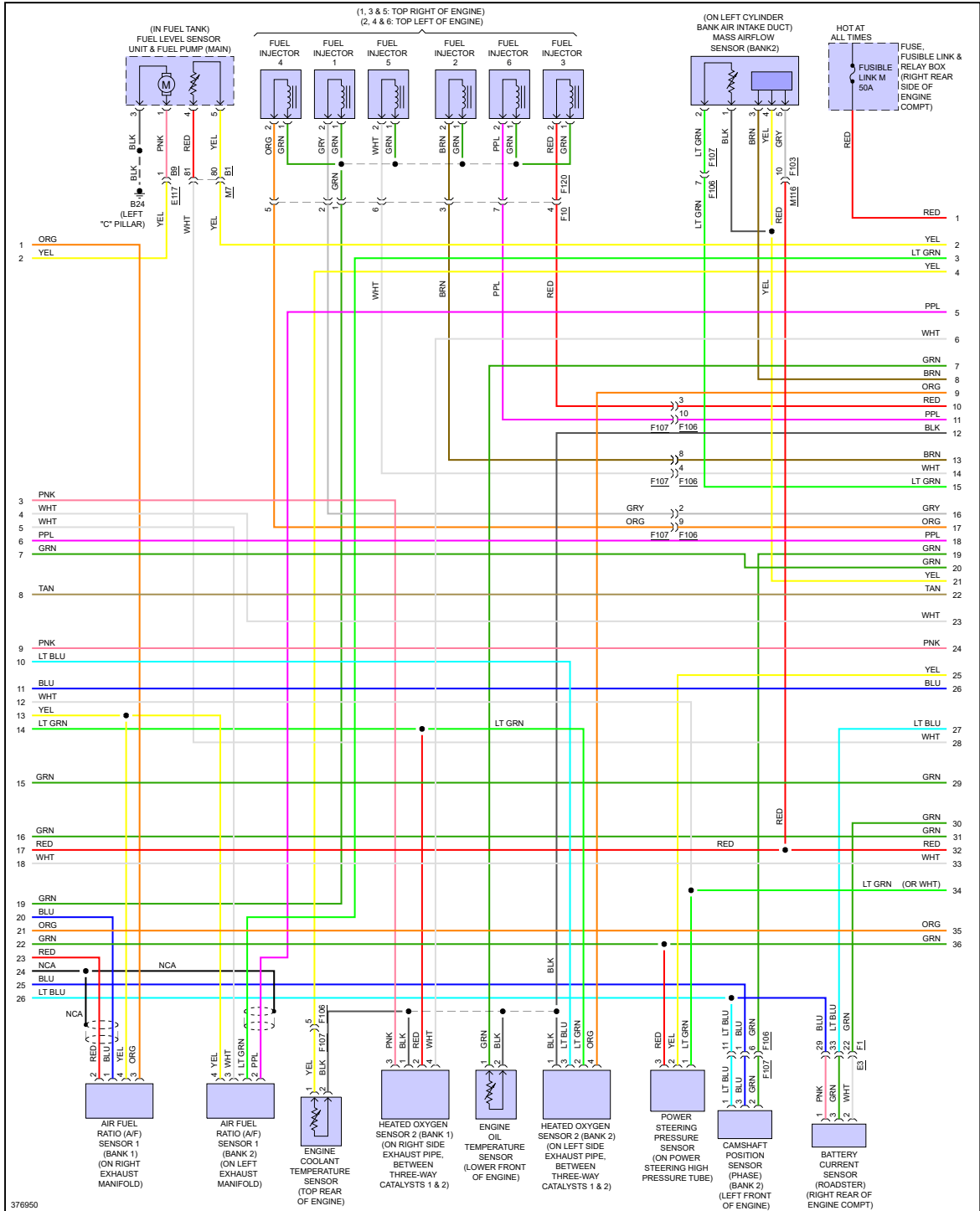
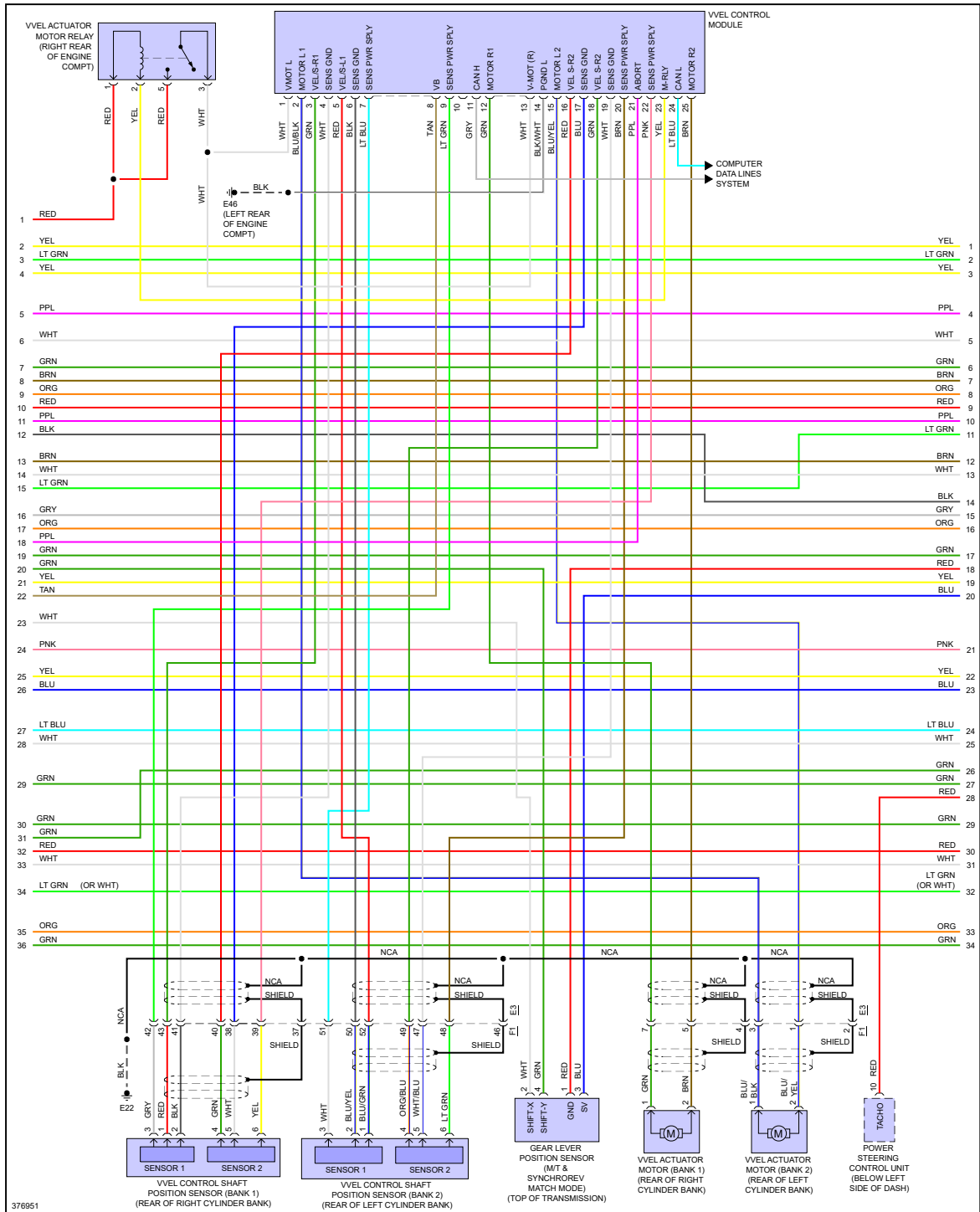
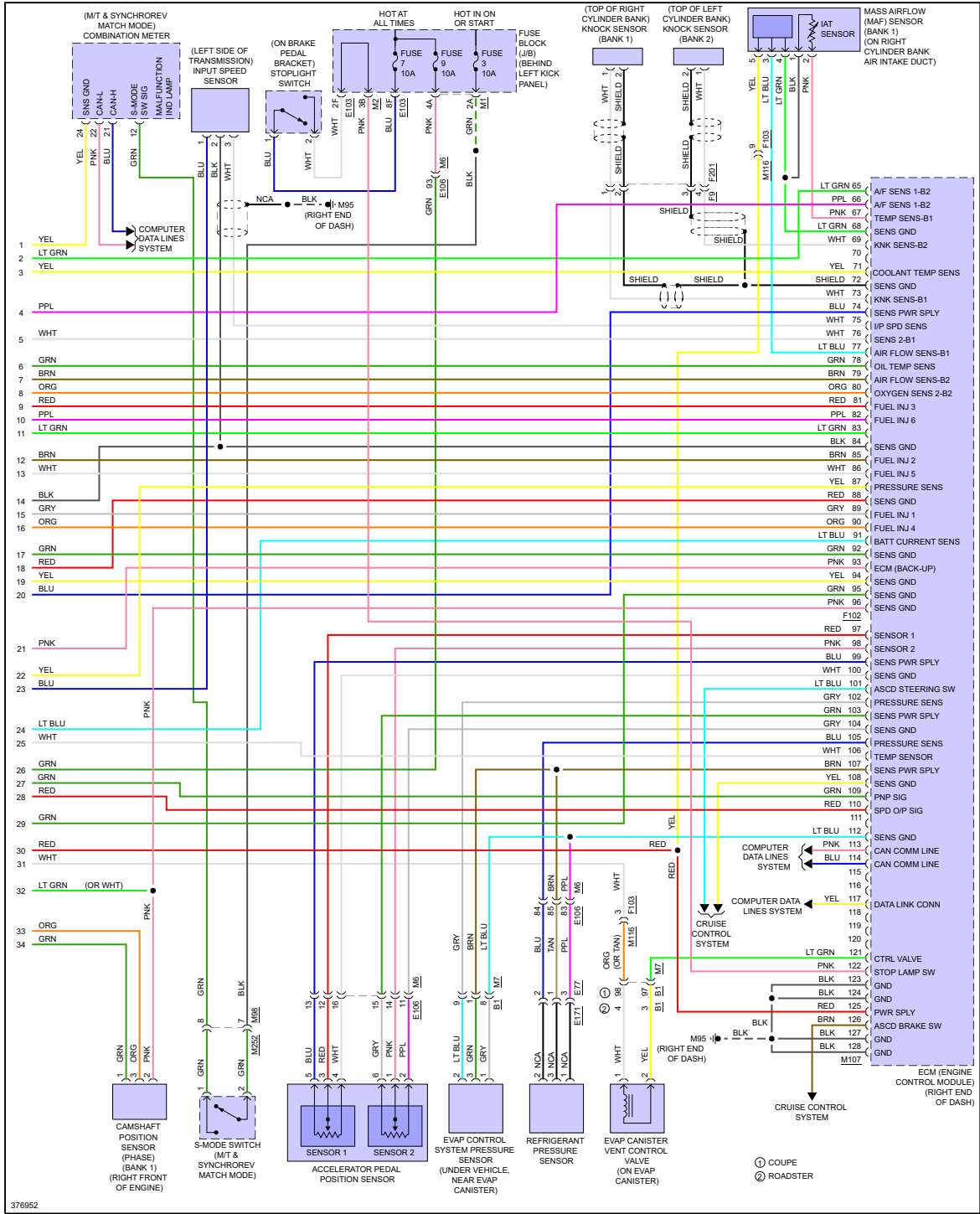

Fig 4: 3.7L, Engine Performance Circuit (4 of 5)



376951

Fig 5: 3.7L, Engine Performance Circuit (5 of 5)



*"If your car is beat down, bring it to P-Town!"*