

YMMS: 2009 Mitsubishi Lancer Ralliart
 Engine: 2.0L Eng
 VIN:

Sep 5, 2022
 License:
 Odometer:

ENGINE PERFORMANCE > 2.0L TURBO

Fig 1: 2.0L Turbo, Engine Performance Circuit (1 of 4)

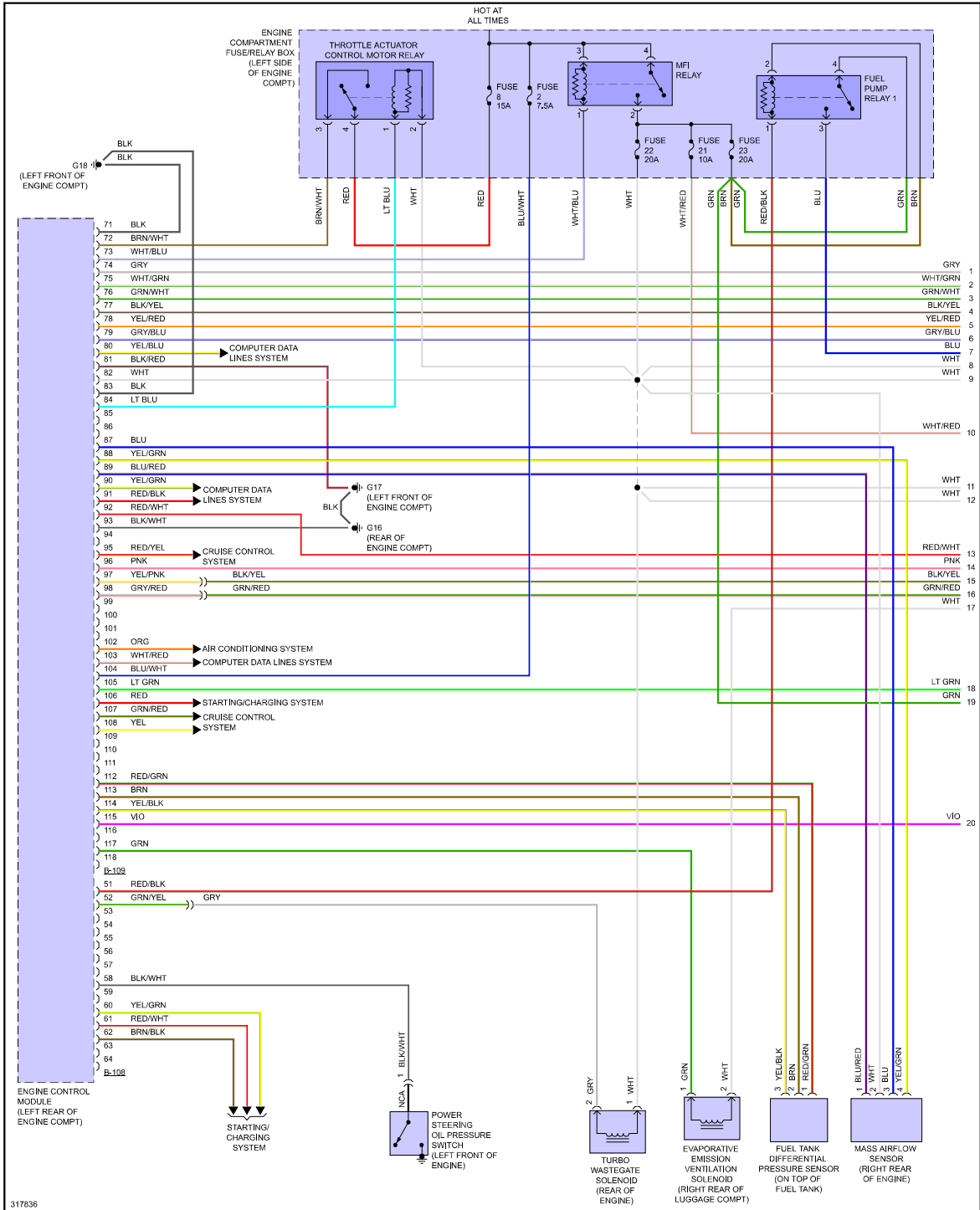

Fig 2: 2.0L Turbo, Engine Performance Circuit (2 of 4)

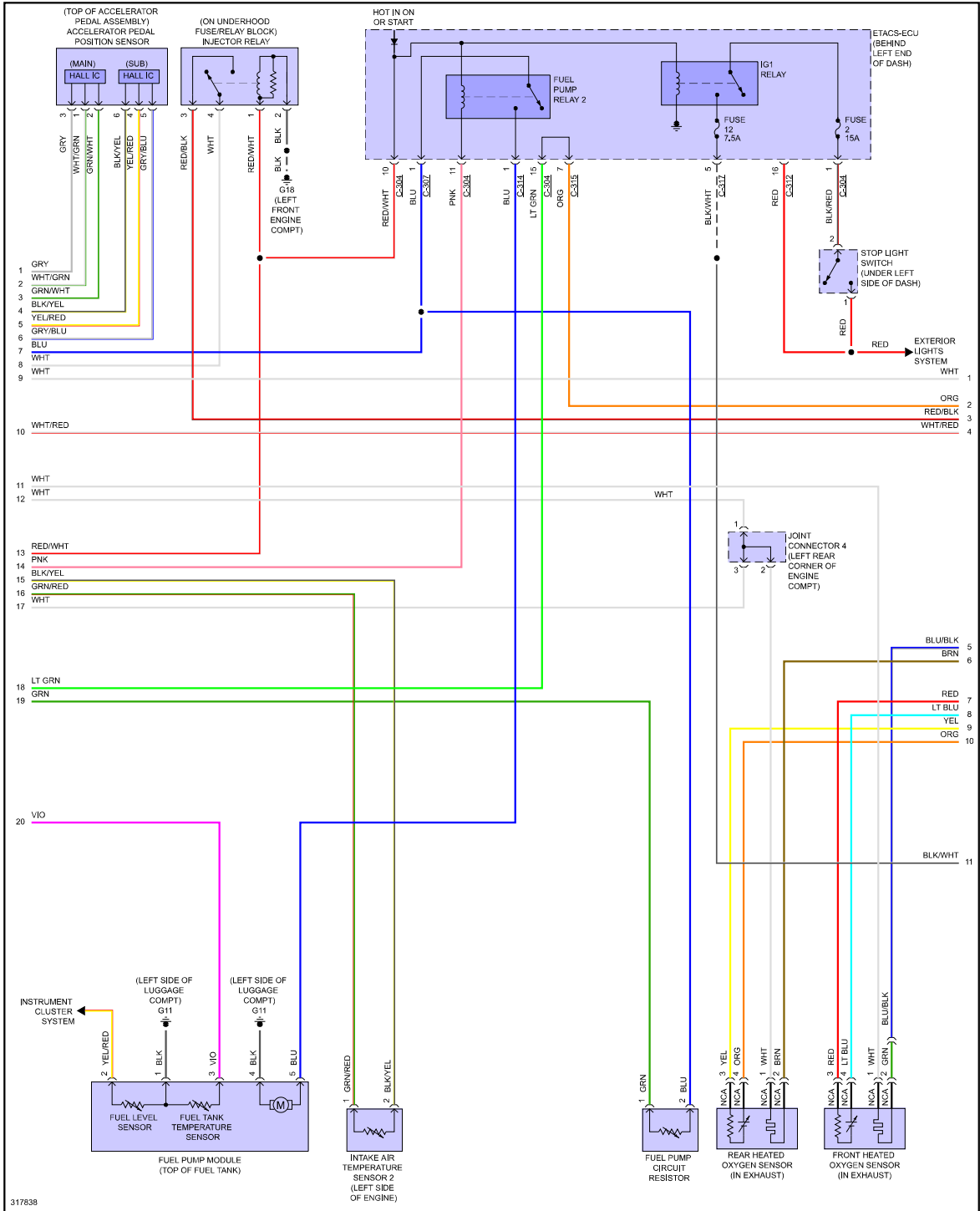

Fig 3: 2.0L Turbo, Engine Performance Circuit (3 of 4)

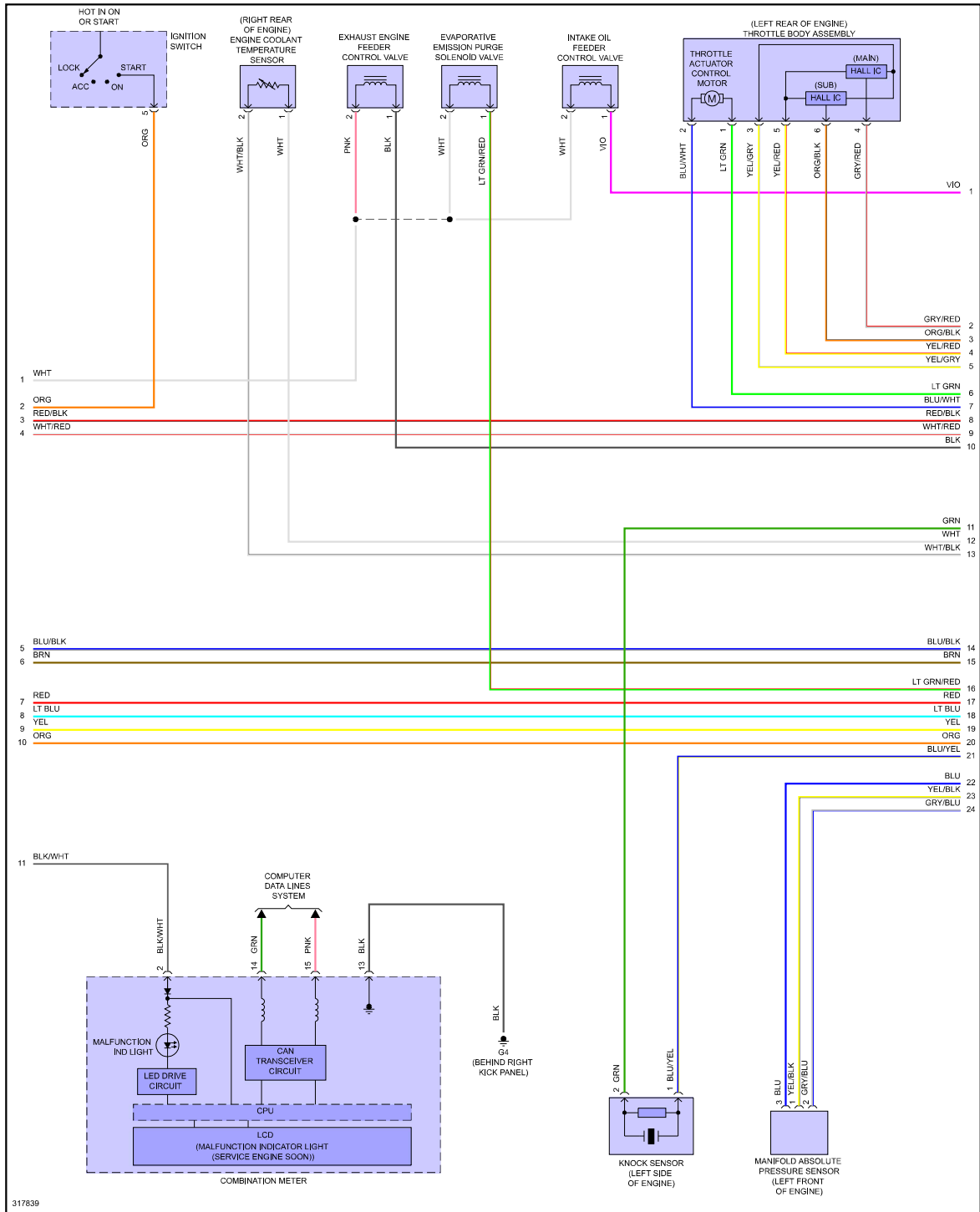
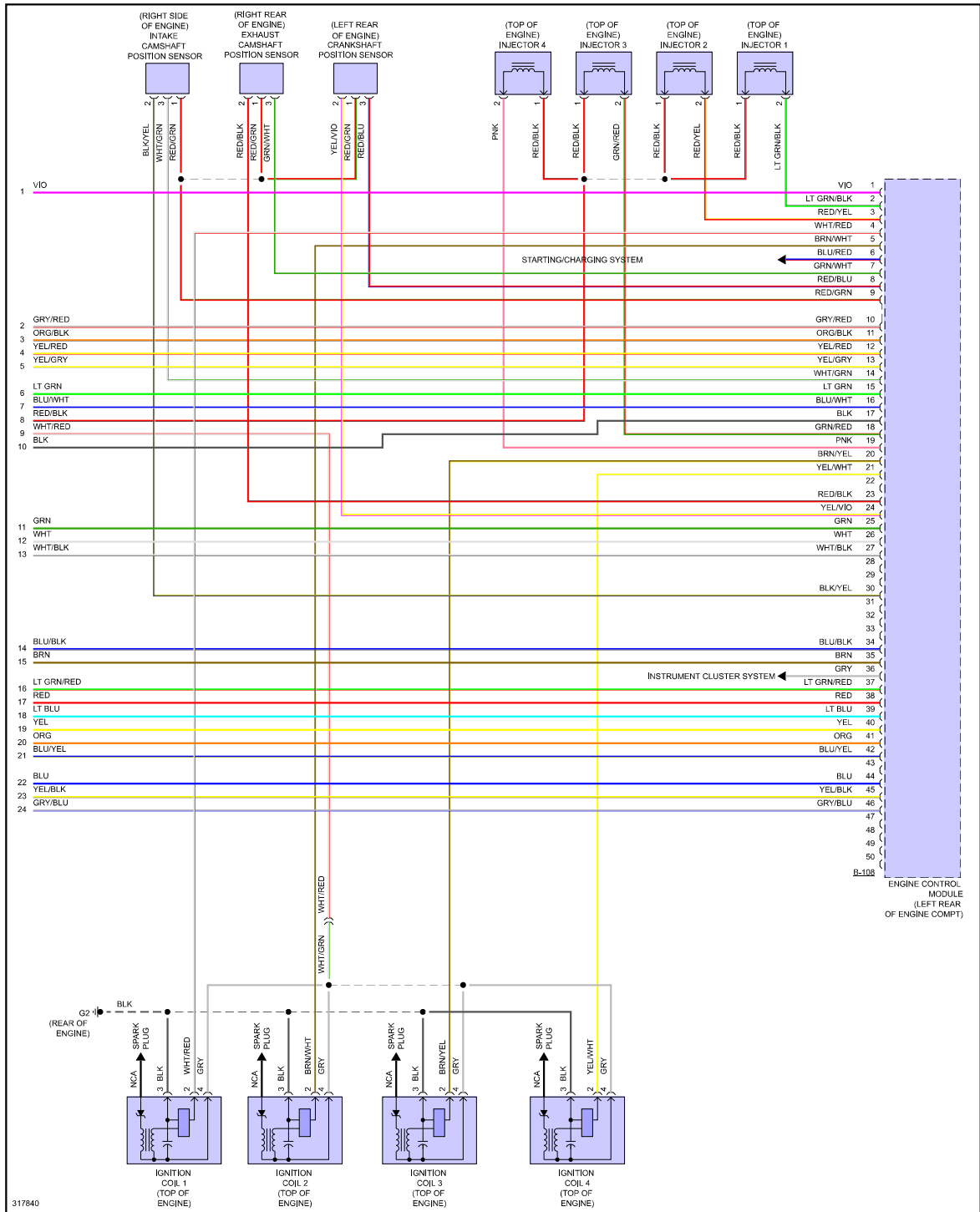

Fig 4: 2.0L Turbo, Engine Performance Circuit (4 of 4)



ENGINE PERFORMANCE > 2.0L

Fig 1: 2.0L, Engine Performance Circuit (1 of 4)

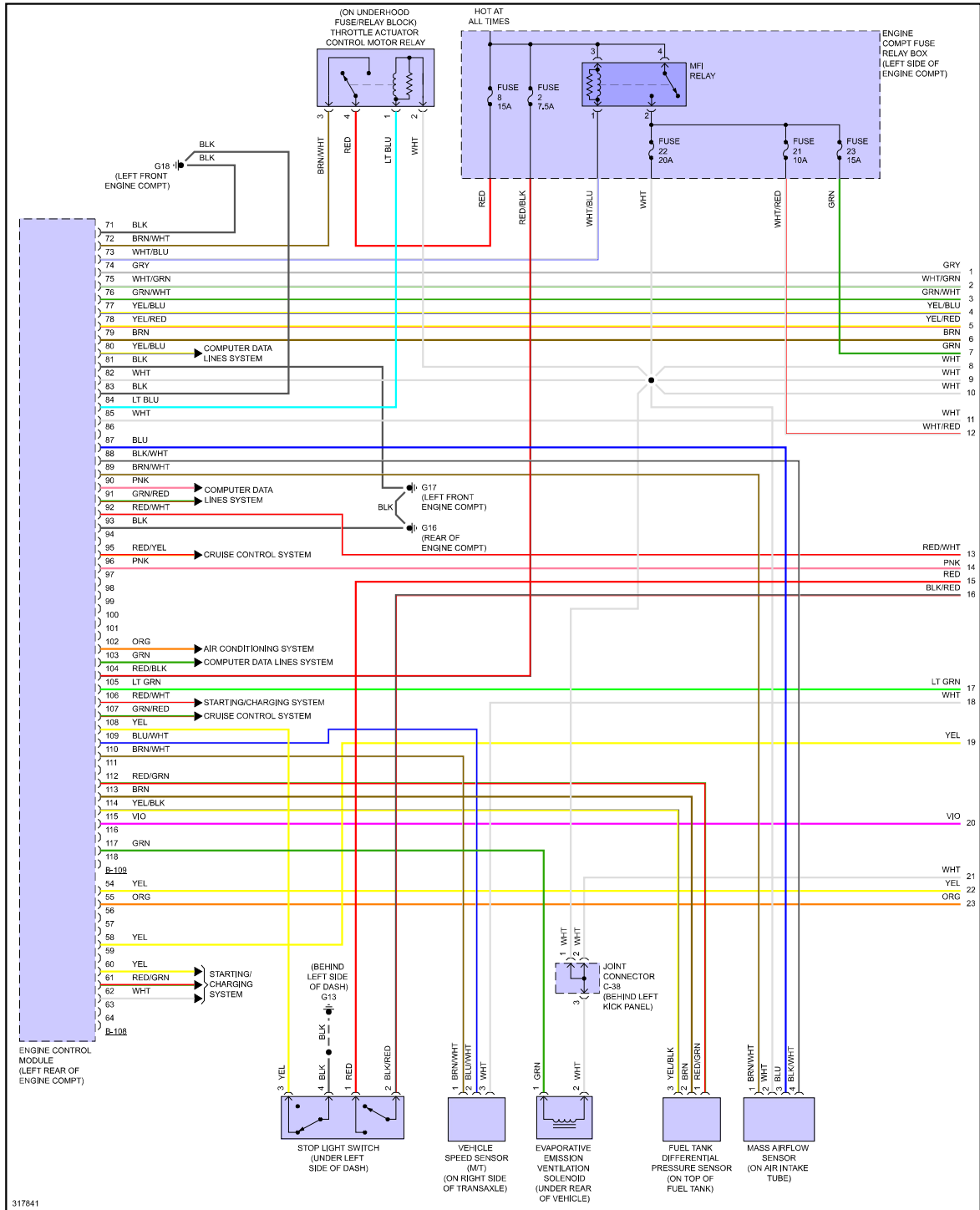

Fig 2: 2.0L, Engine Performance Circuit (2 of 4)

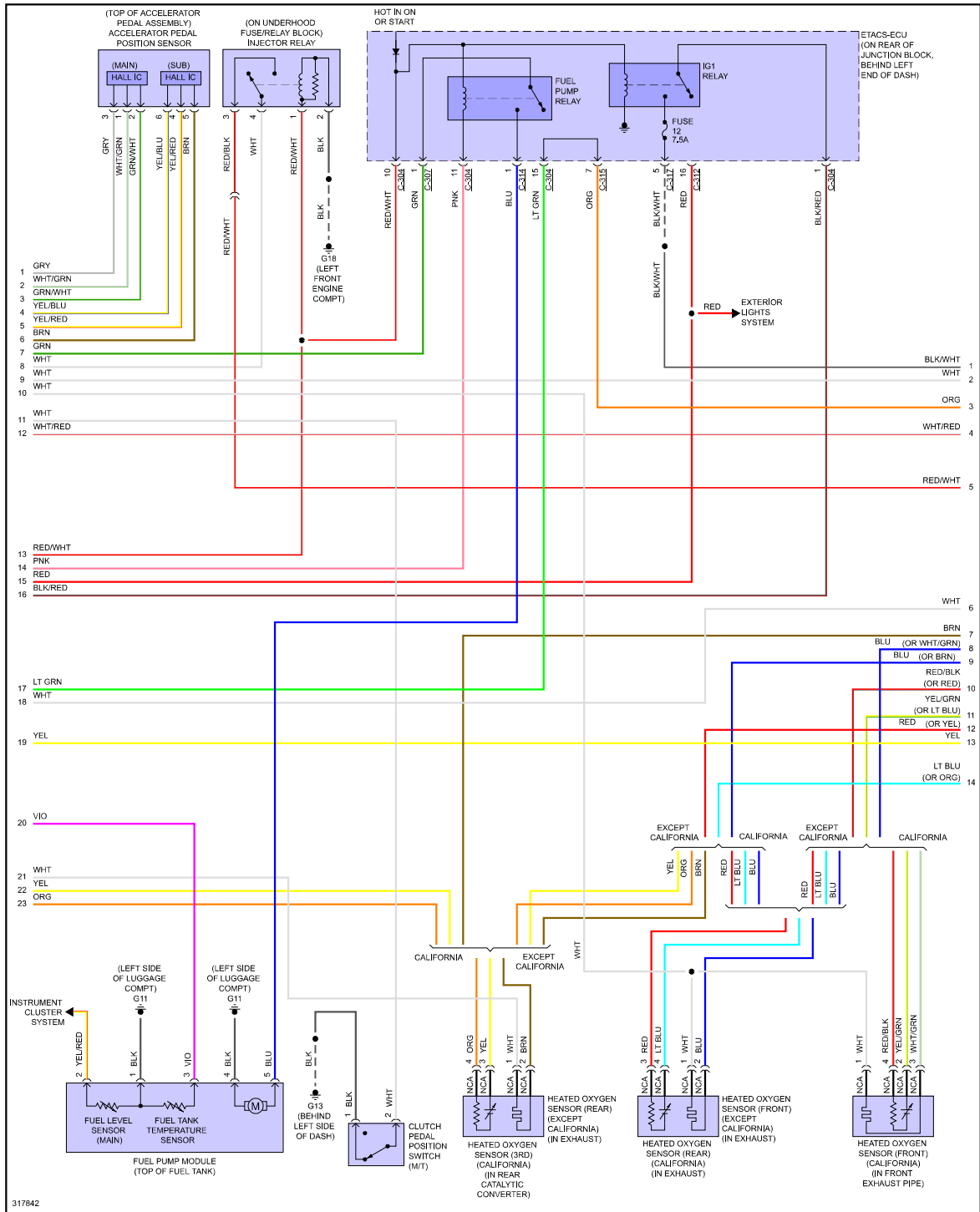

Fig 3: 2.0L, Engine Performance Circuit (3 of 4)

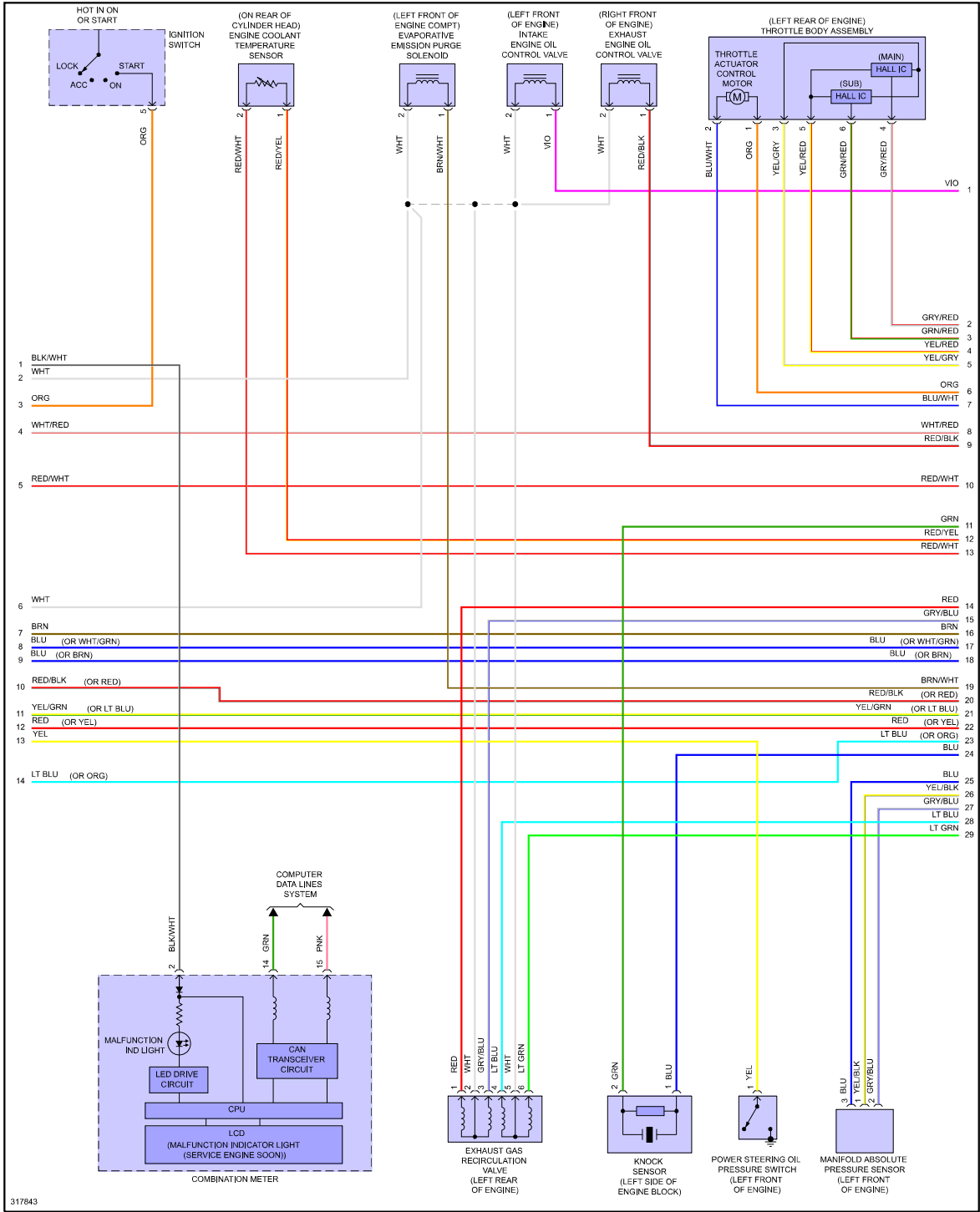
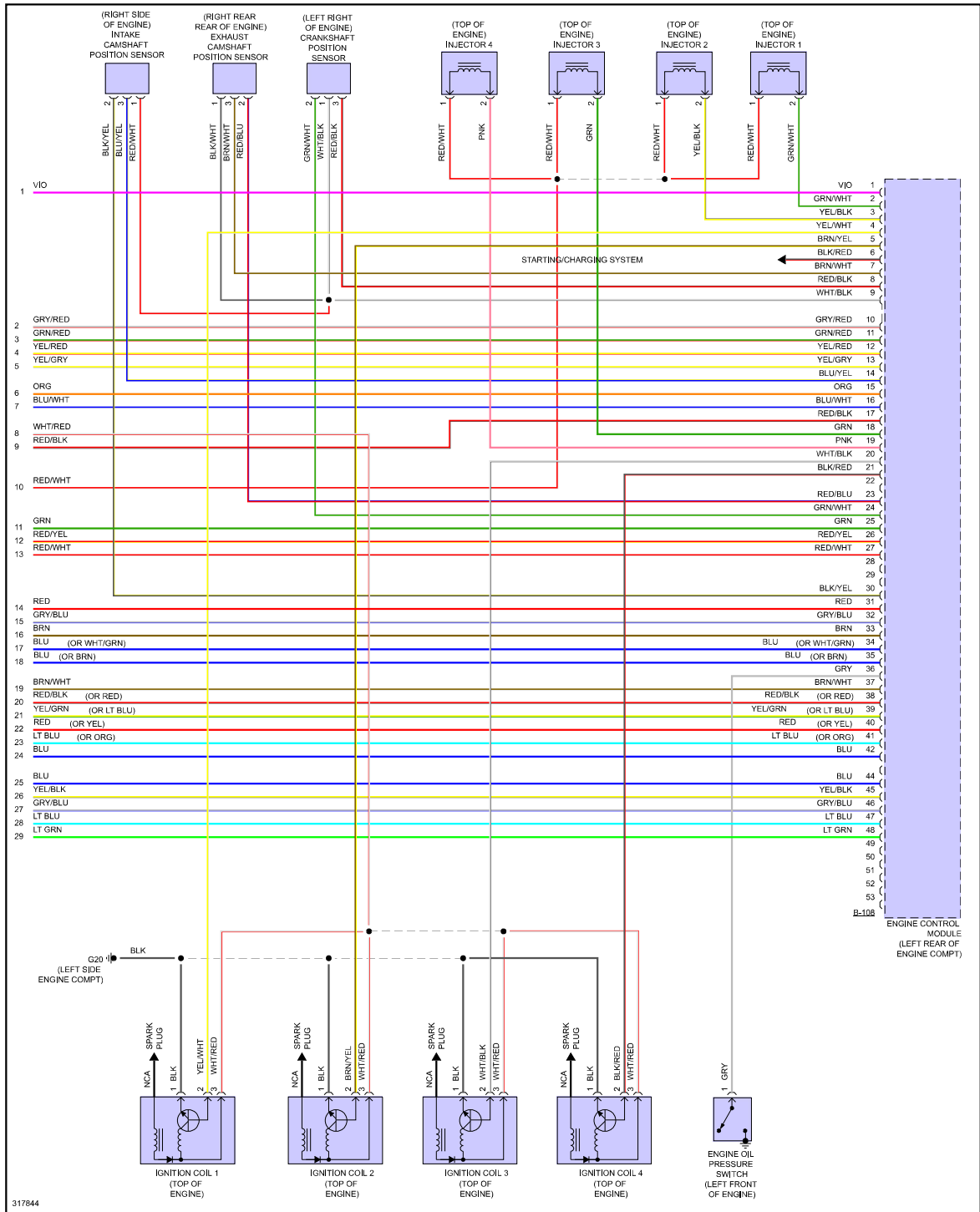

Fig 4: 2.0L, Engine Performance Circuit (4 of 4)



ENGINE PERFORMANCE > 2.4L

Fig 1: 2.4L, Engine Performance Circuit (1 of 4)

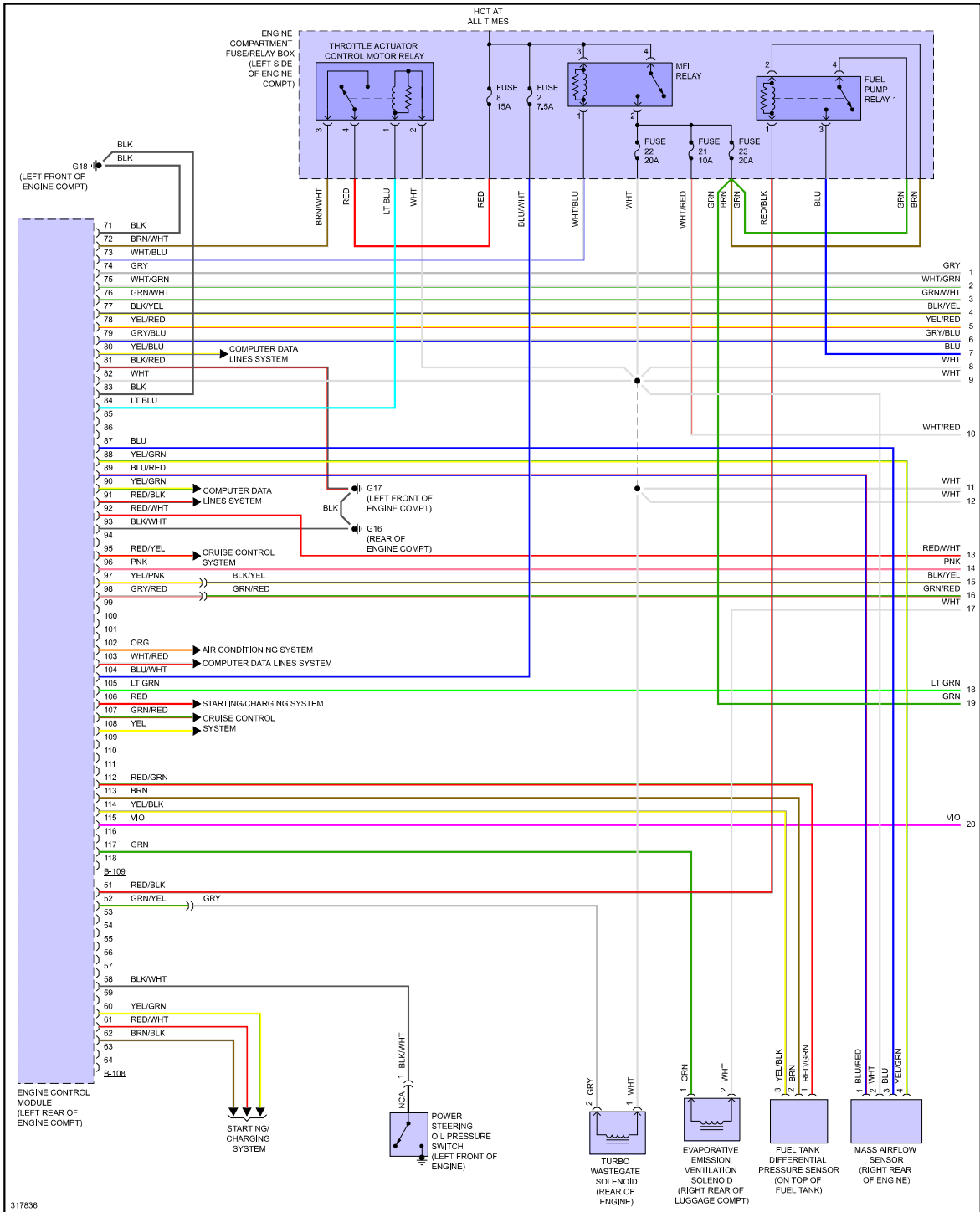

Fig 2: 2.4L, Engine Performance Circuit (2 of 4)

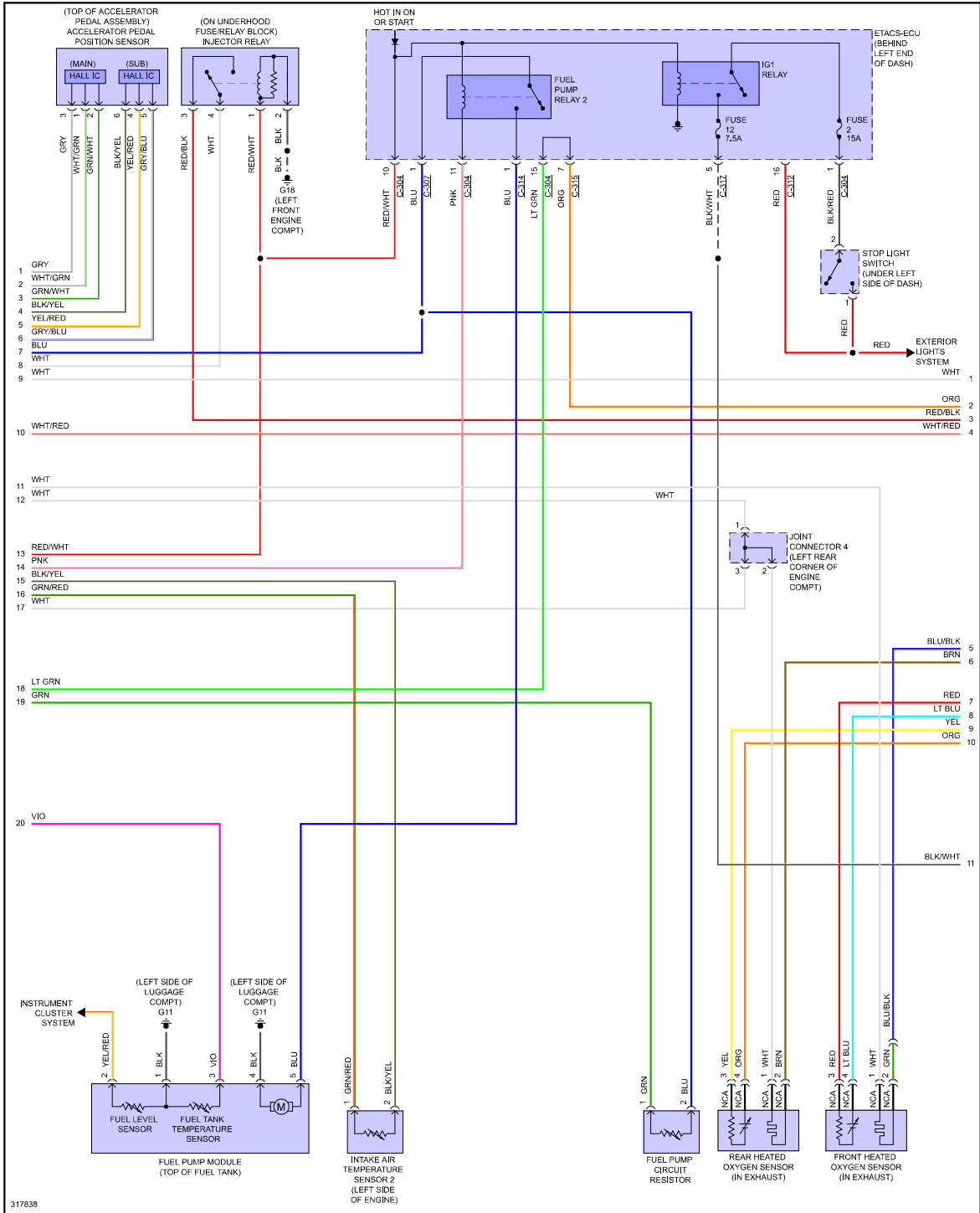

Fig 3: 2.4L, Engine Performance Circuit (3 of 4)

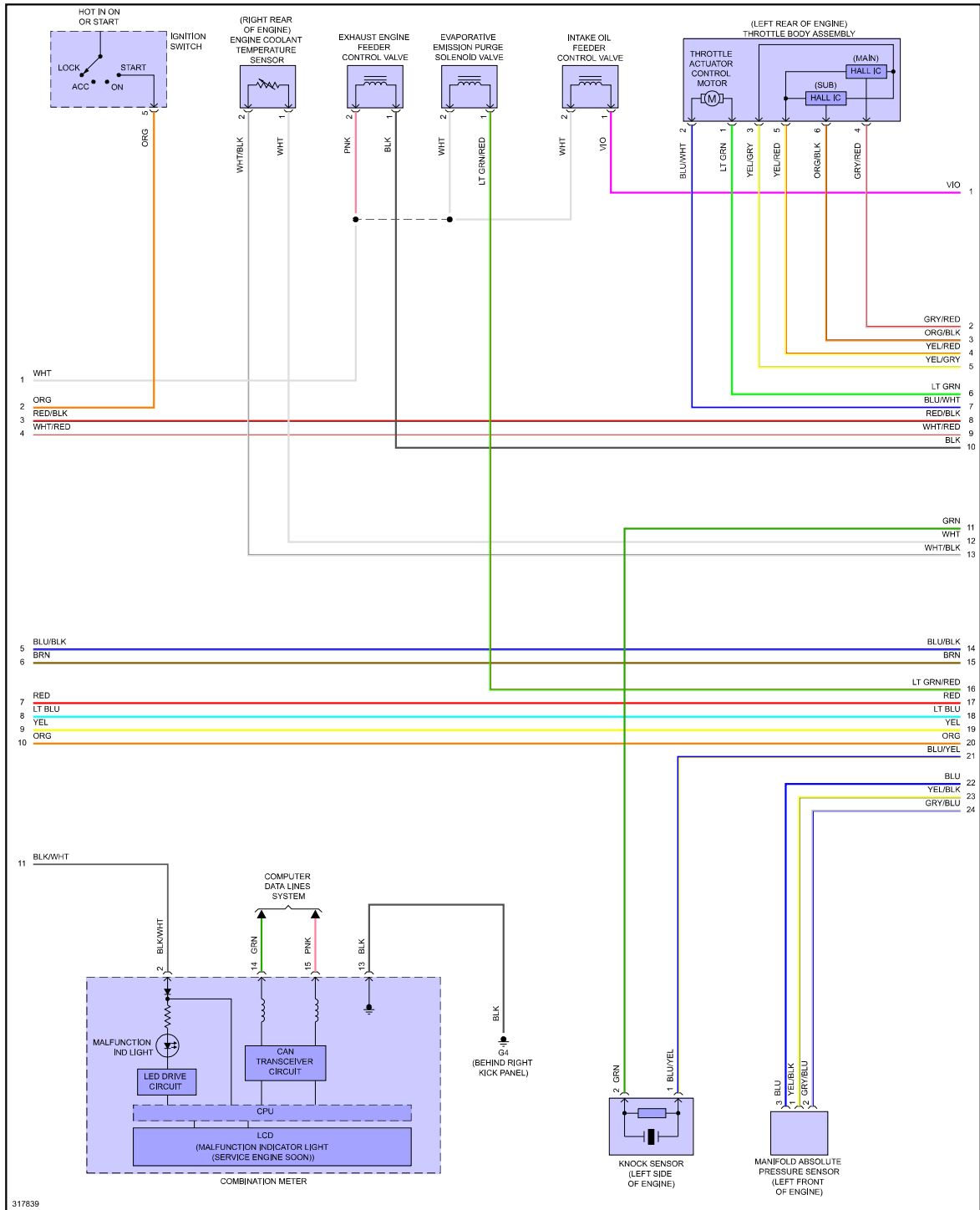

Fig 4: 2.4L, Engine Performance Circuit (4 of 4)

