

P-Town Auto & Offroad, LLC

688 Harshaw Ave.
Patagonia, AZ 85624
(520) 394-0181 T

YMMS: 2018 Chrysler 300 S

Engine: 3.6L Eng

VIN:

Jun 7, 2024

License:

Odometer:

COMPUTER DATA LINES

Fig 1: Computer Data Lines Circuit (1 of 4)

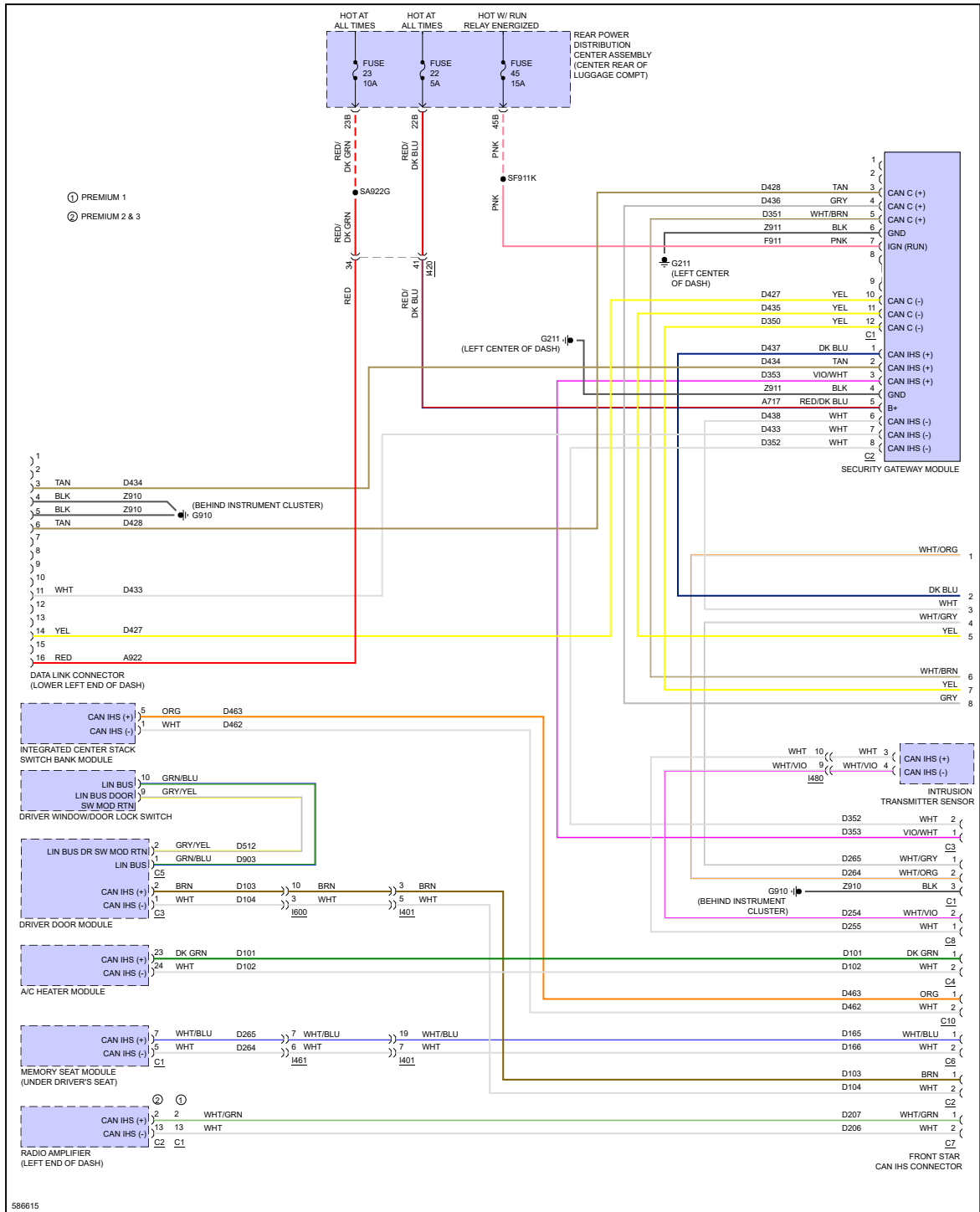

Fig 2: Computer Data Lines Circuit (2 of 4)

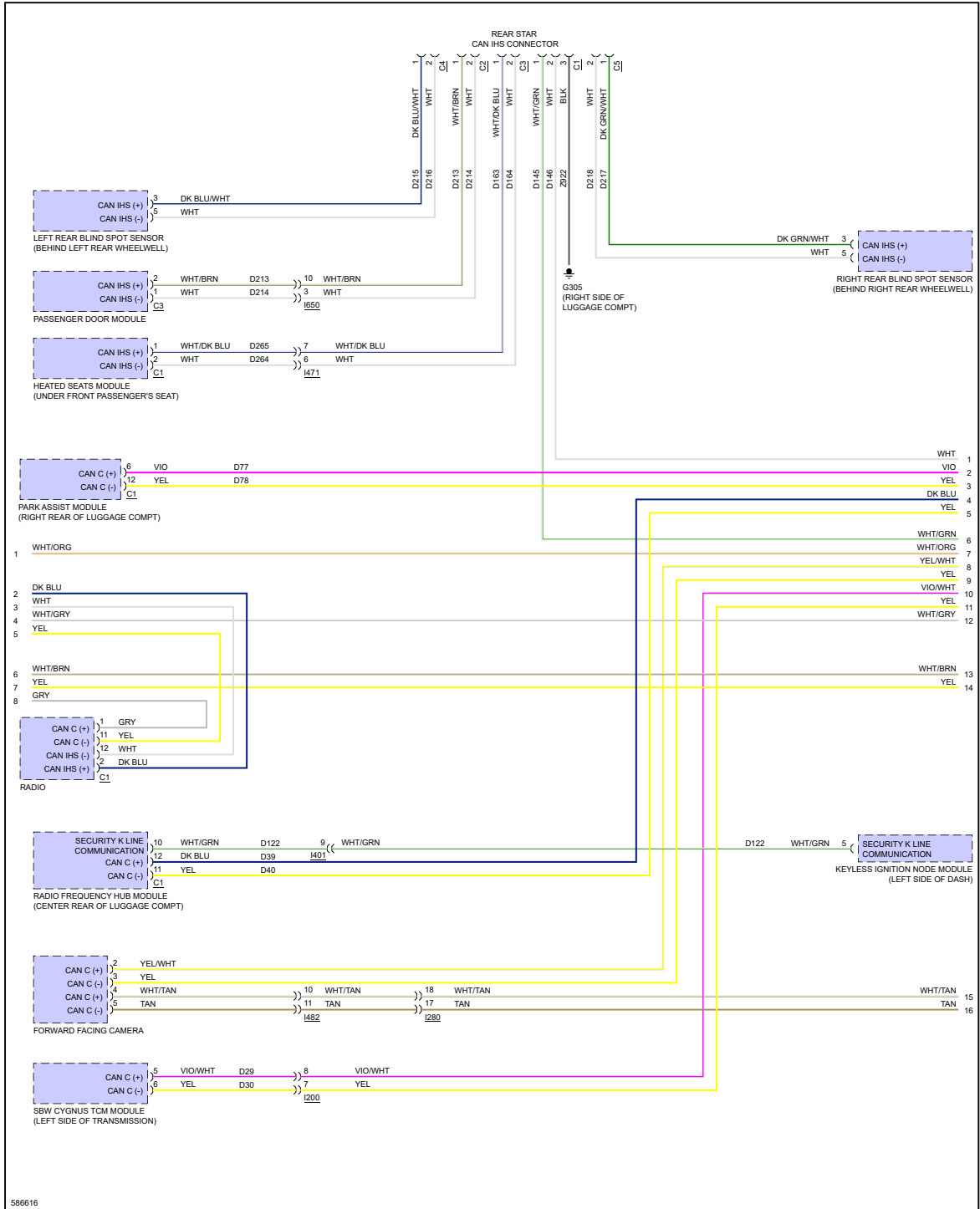

Fig 3: Computer Data Lines Circuit (3 of 4)

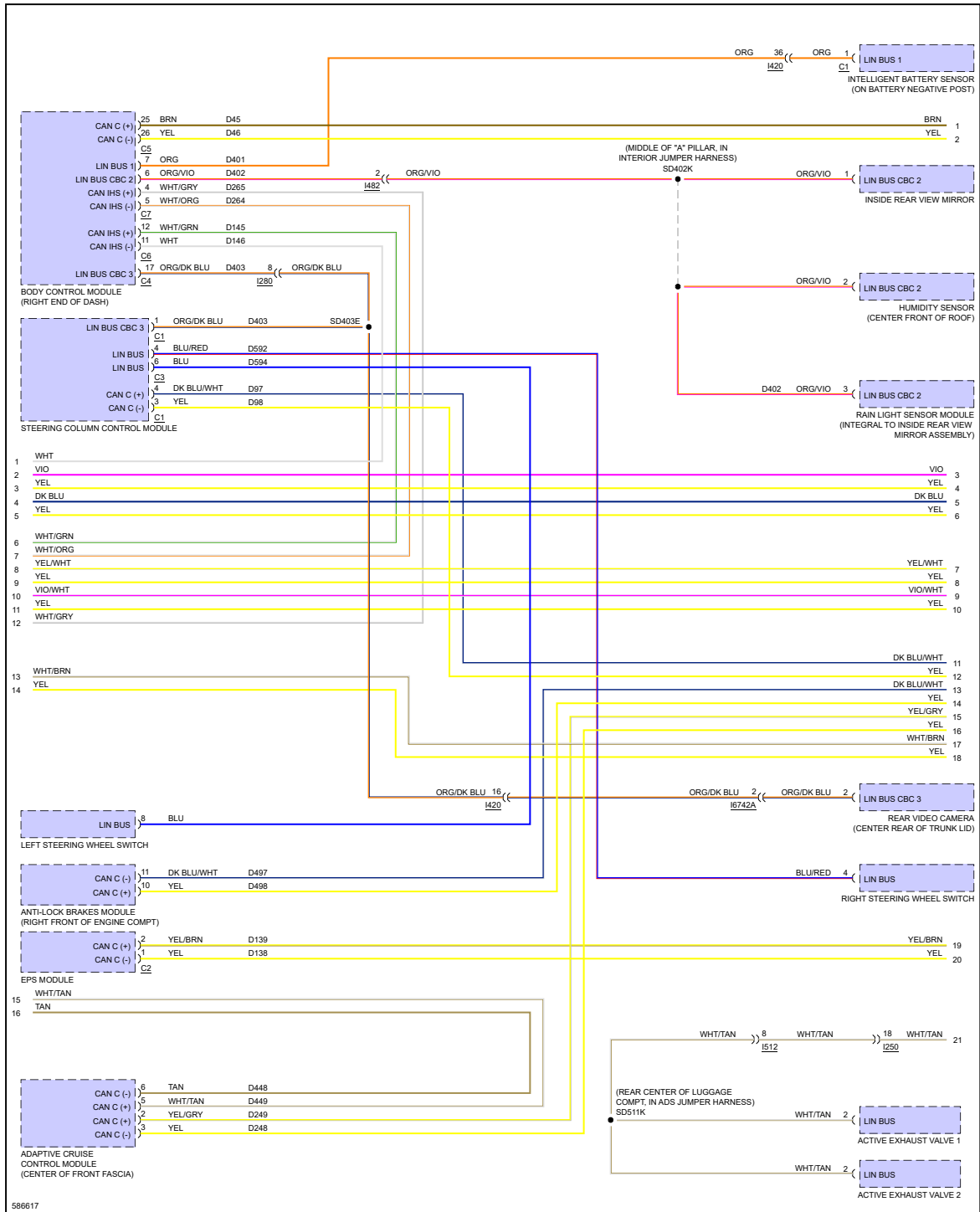
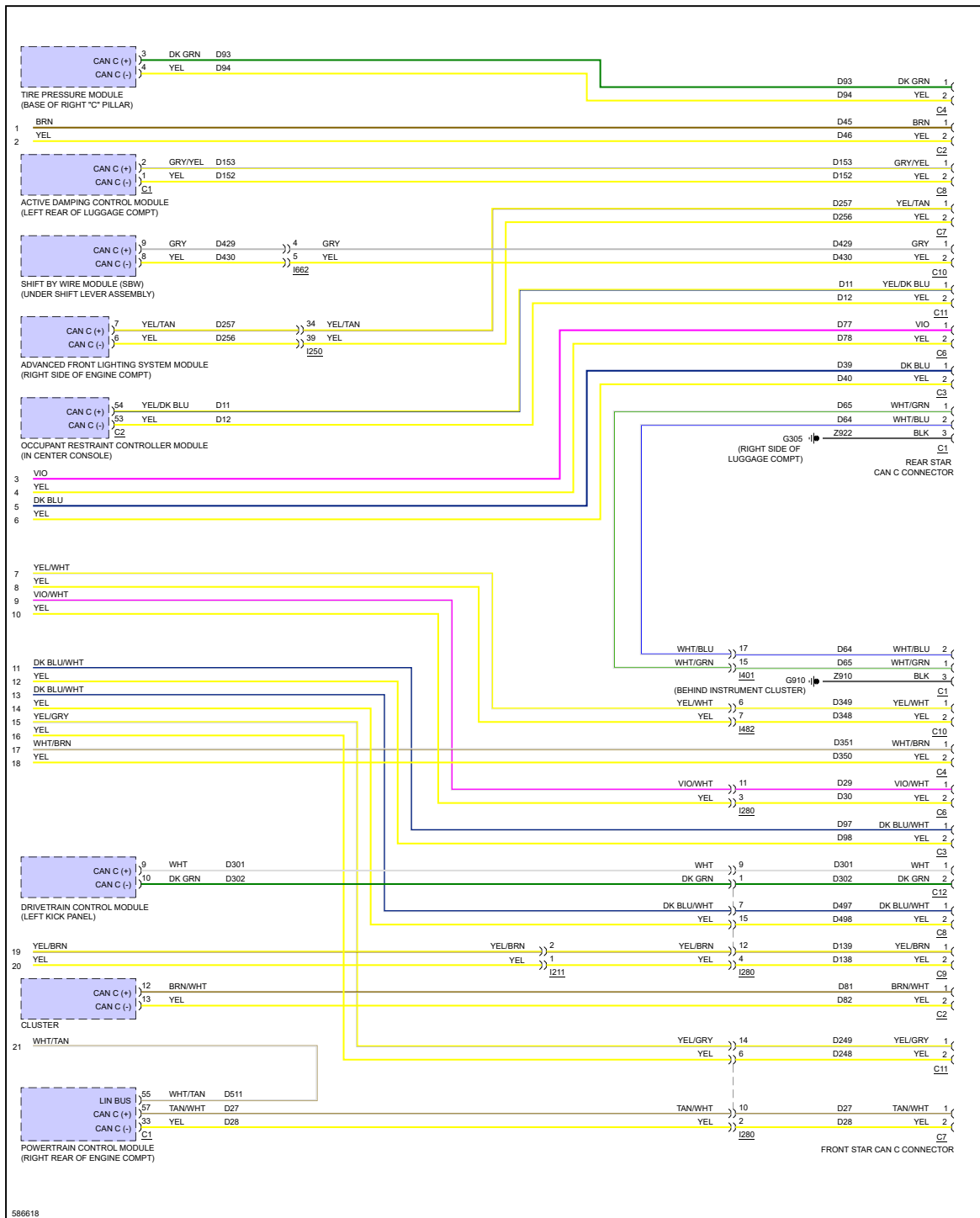

Fig 4: Computer Data Lines Circuit (4 of 4)



"If your car is beat down, bring it to P-Town!"