

Prax Truck & Auto Repair LLC

956-784-1818

YMMS: 2014 Kia Forte EX

Engine: 2.0L Eng

VIN:

Feb 23, 2024

License:

Odometer:

ENGINE PERFORMANCE > 2.0L

Fig 1: 2.0L, Electric Oil Pump Circuit

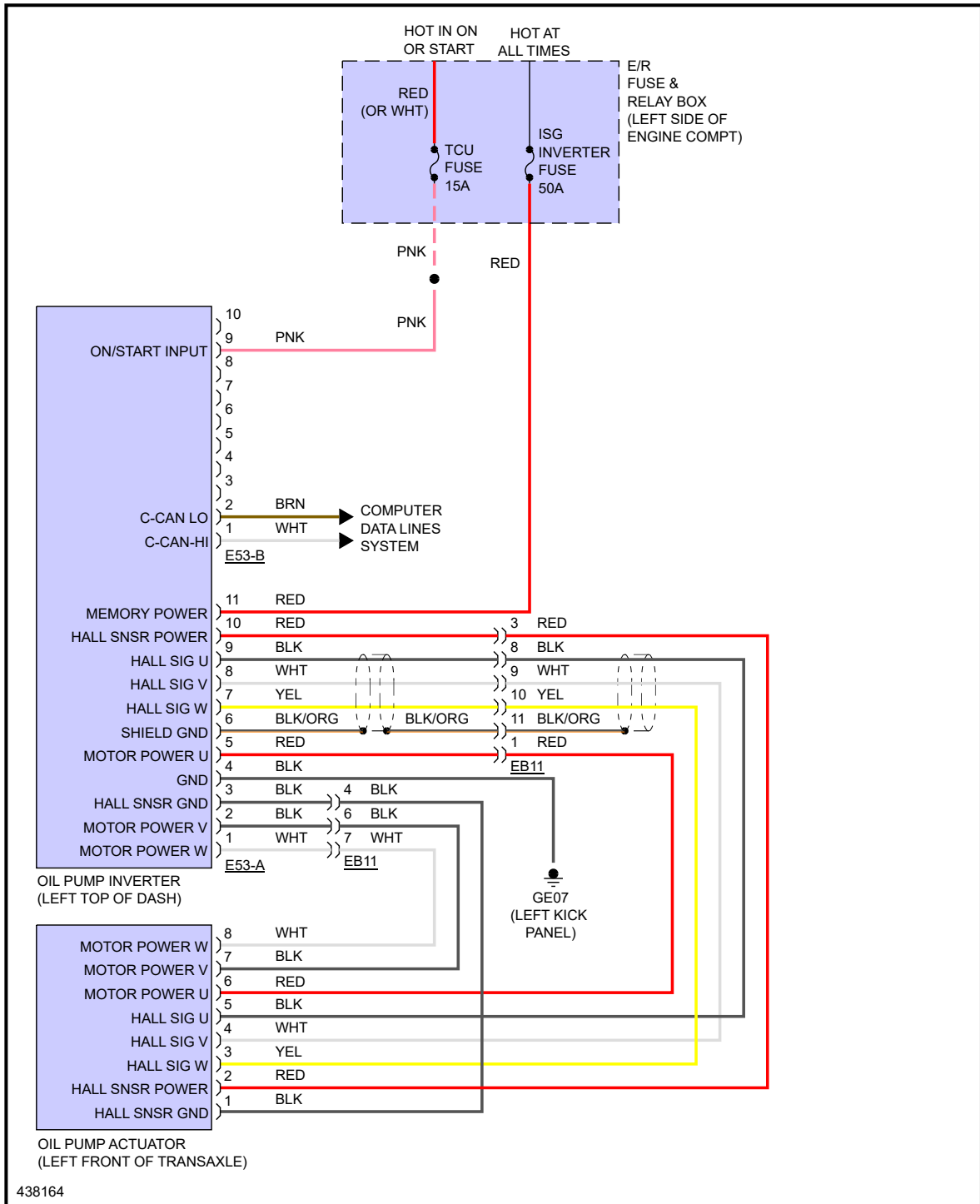
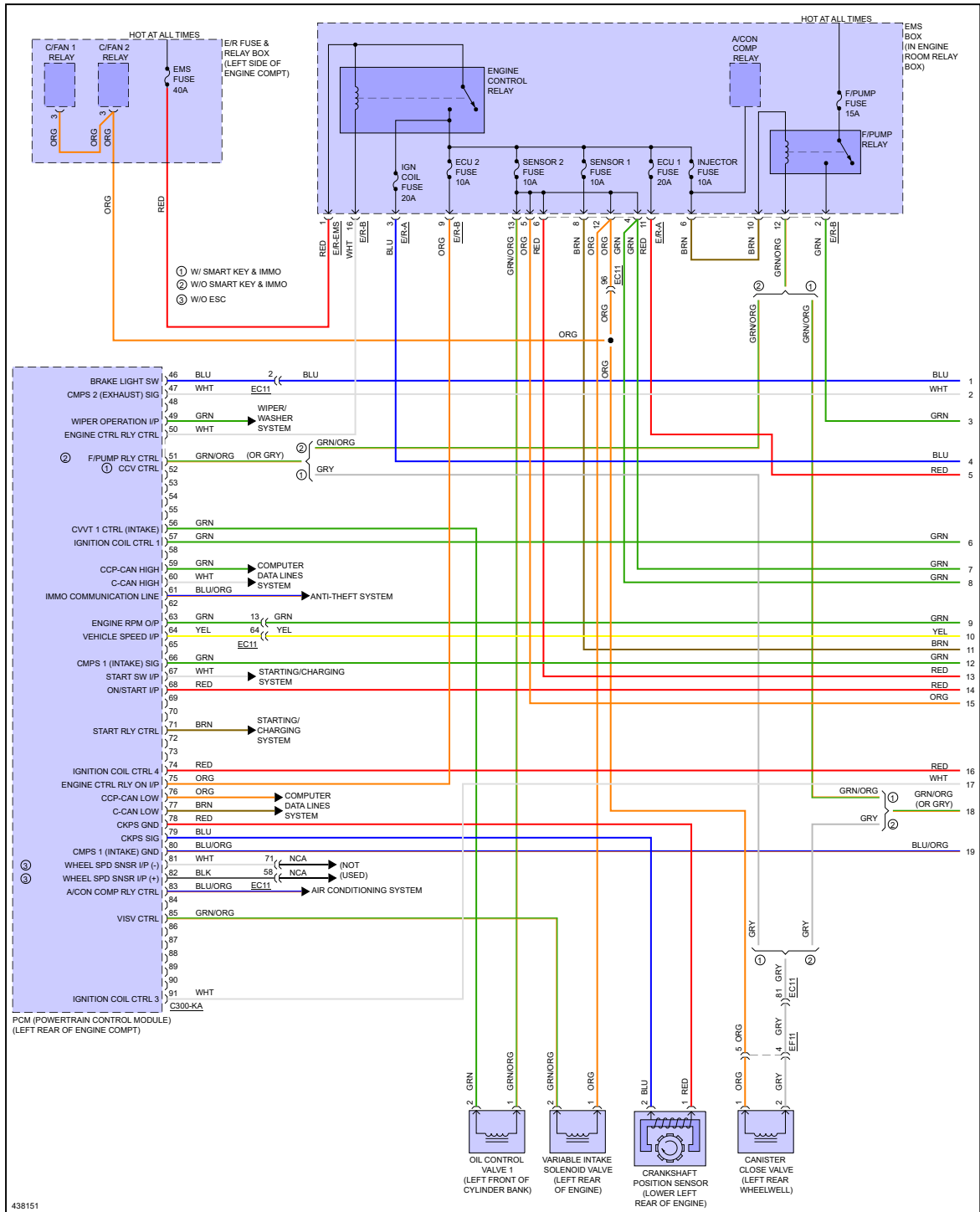

Fig 2: 2.0L, MFI Control Circuit (1 of 7)



438151

Fig 3: 2.0L, MFI Control Circuit (2 of 7)

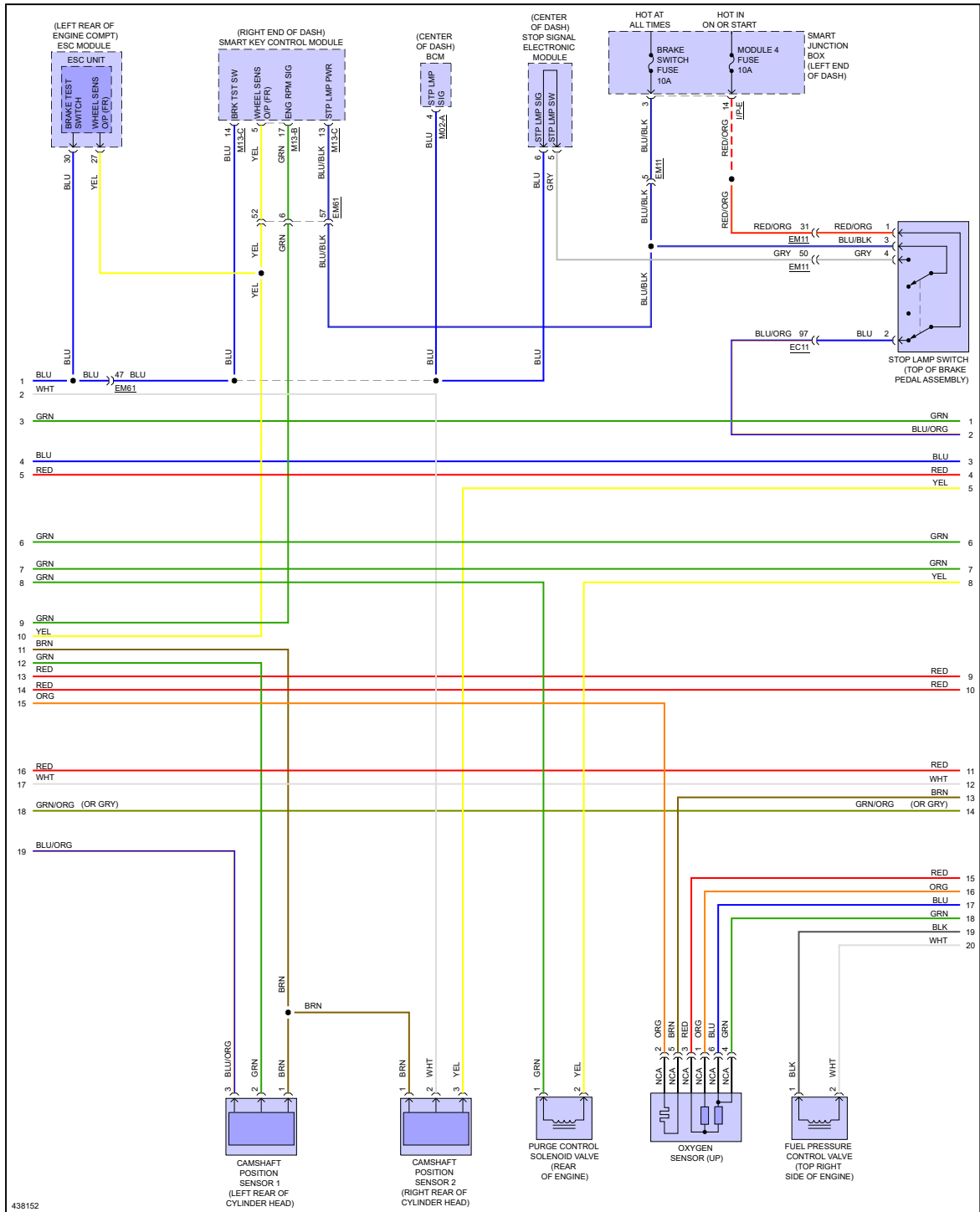

Fig 4: 2.0L, MFI Control Circuit (3 of 7)

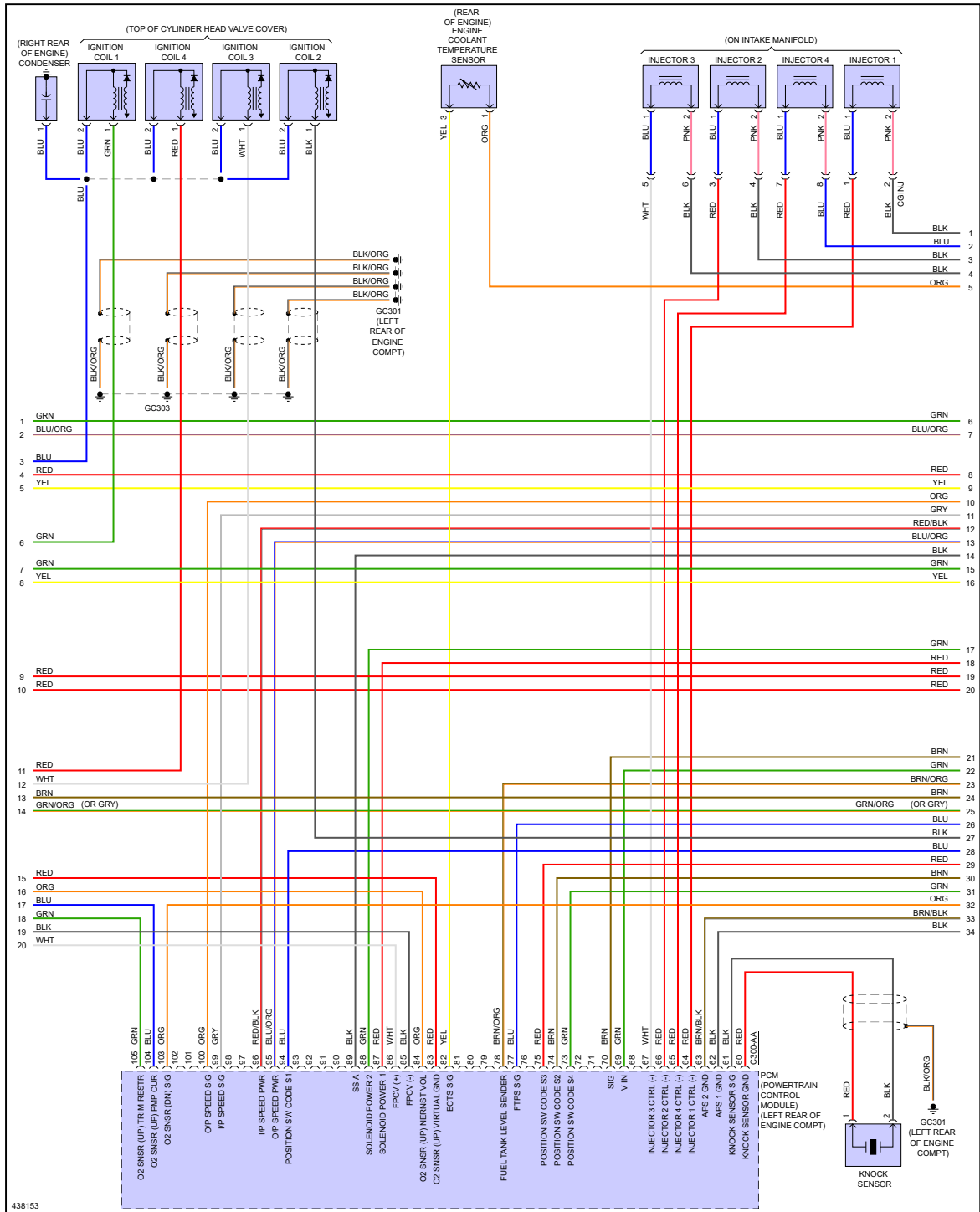

Fig 5: 2.0L, MFI Control Circuit (4 of 7)

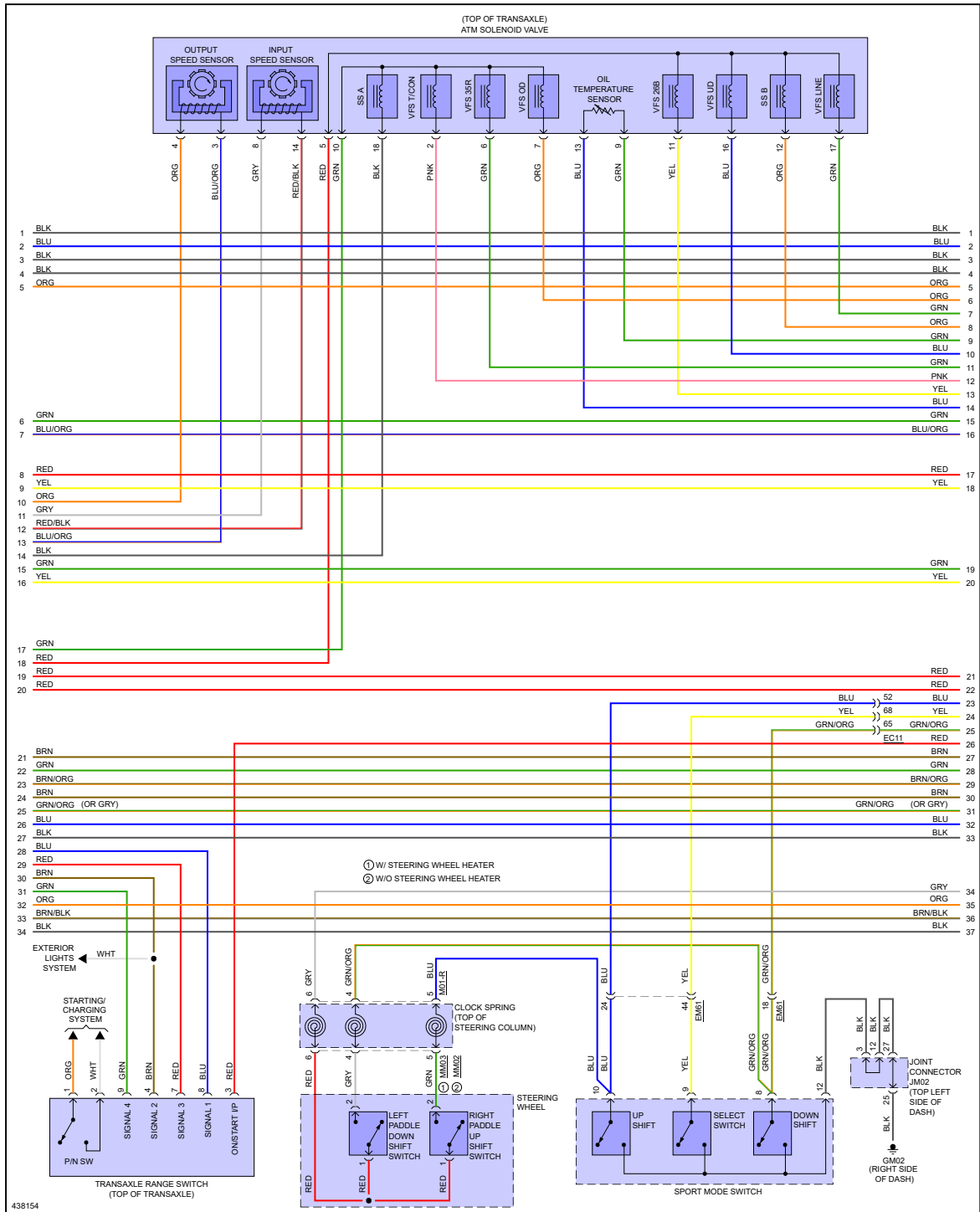

Fig 6: 2.0L, MFI Control Circuit (5 of 7)

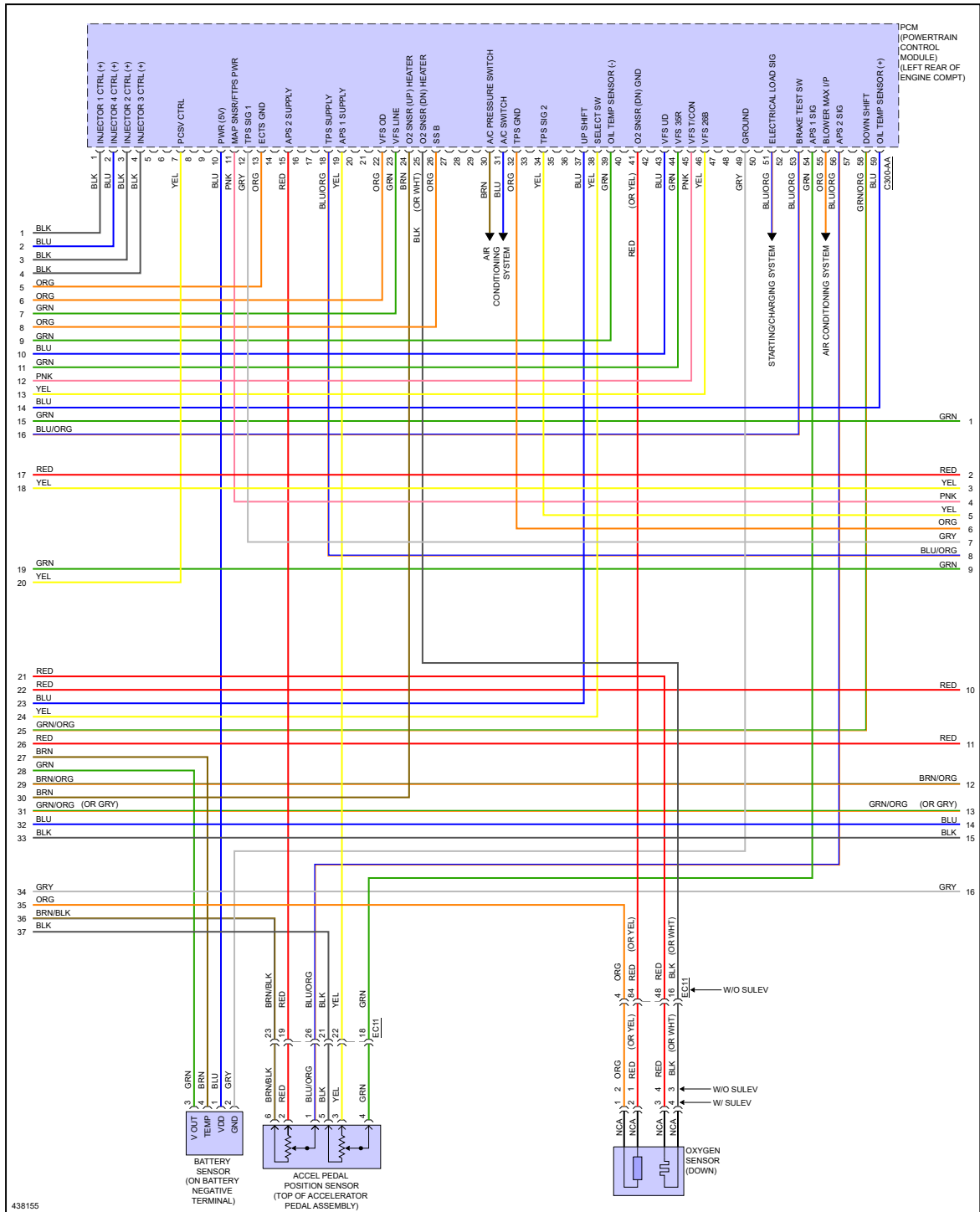

Fig 7: 2.0L, MFI Control Circuit (6 of 7)

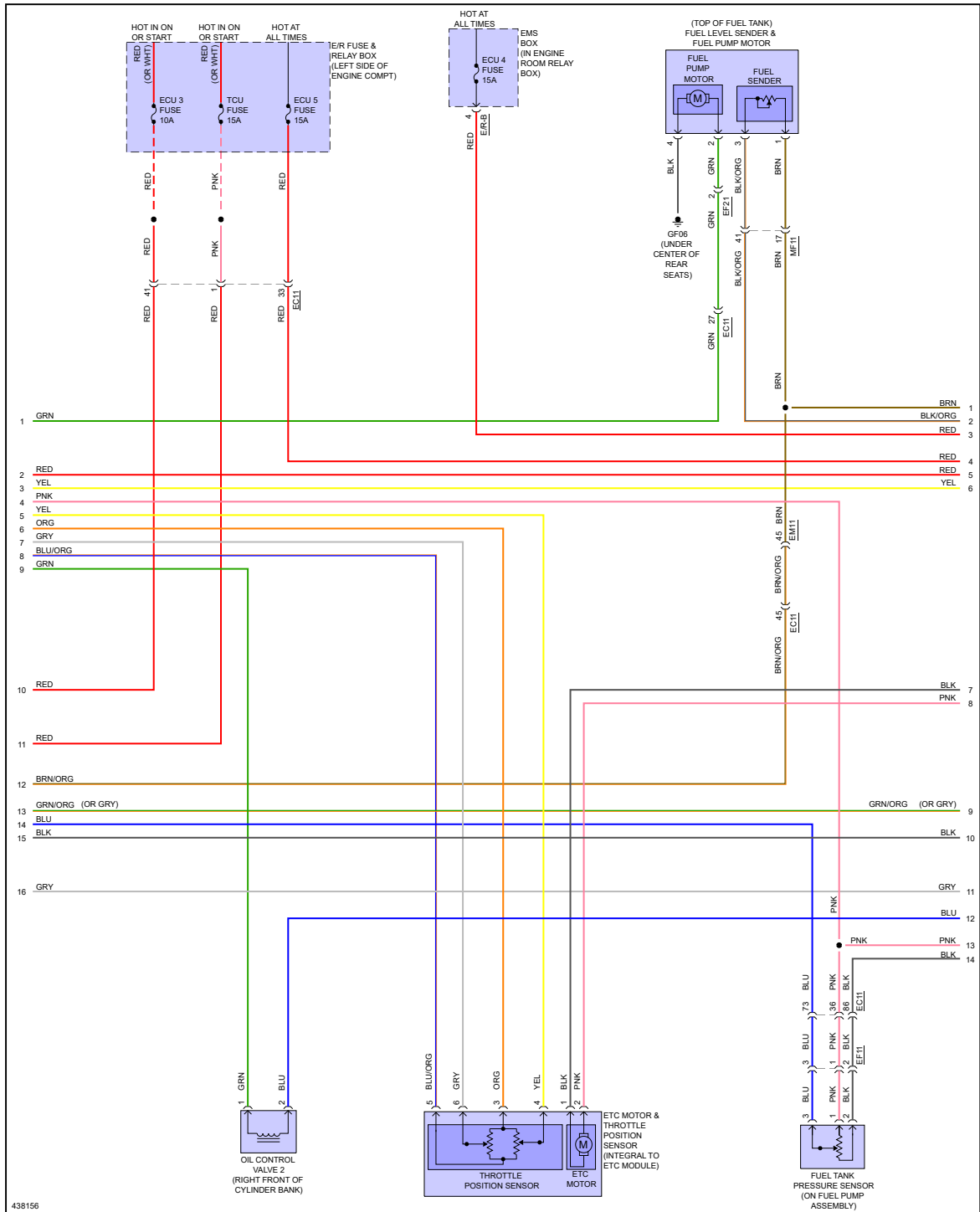

Fig 8: 2.0L, MFI Control Circuit (7 of 7)

