

# P-Town Auto & Offroad, LLC

688 Harshaw Ave.  
Patagonia, AZ 85624  
(520) 394-0181 T

YMMS: 2020 Genesis G70 2.0T

Engine: 2.0L Eng

VIN:

Sep 1, 2024

License:

Odometer:

**ENGINE PERFORMANCE > 2.0L TURBO**

Fig 1: 2.0L Turbo, Electric Oil Pump Circuit

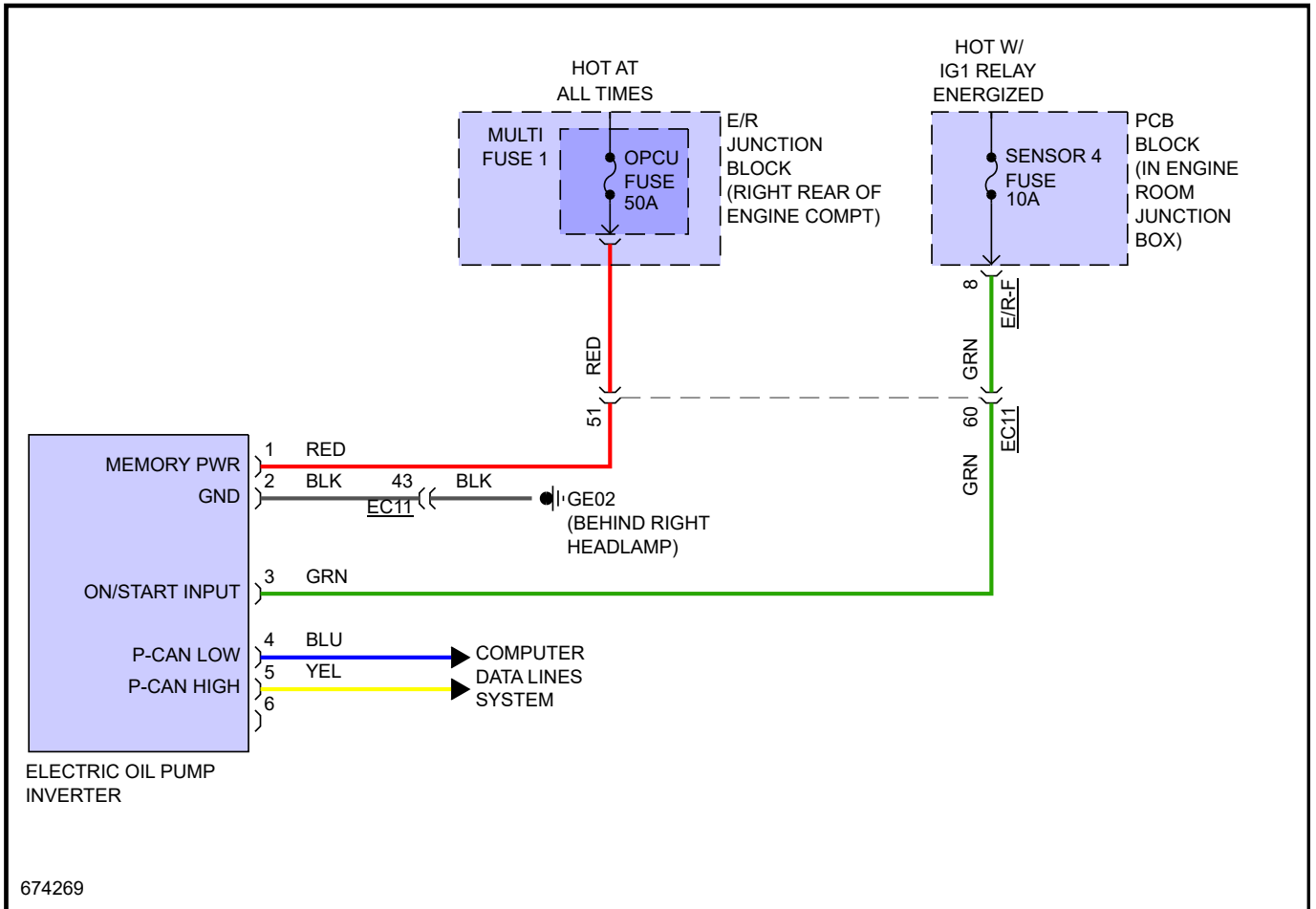

Fig 2: 2.0L Turbo, Engine Controls Circuit (1 of 7)

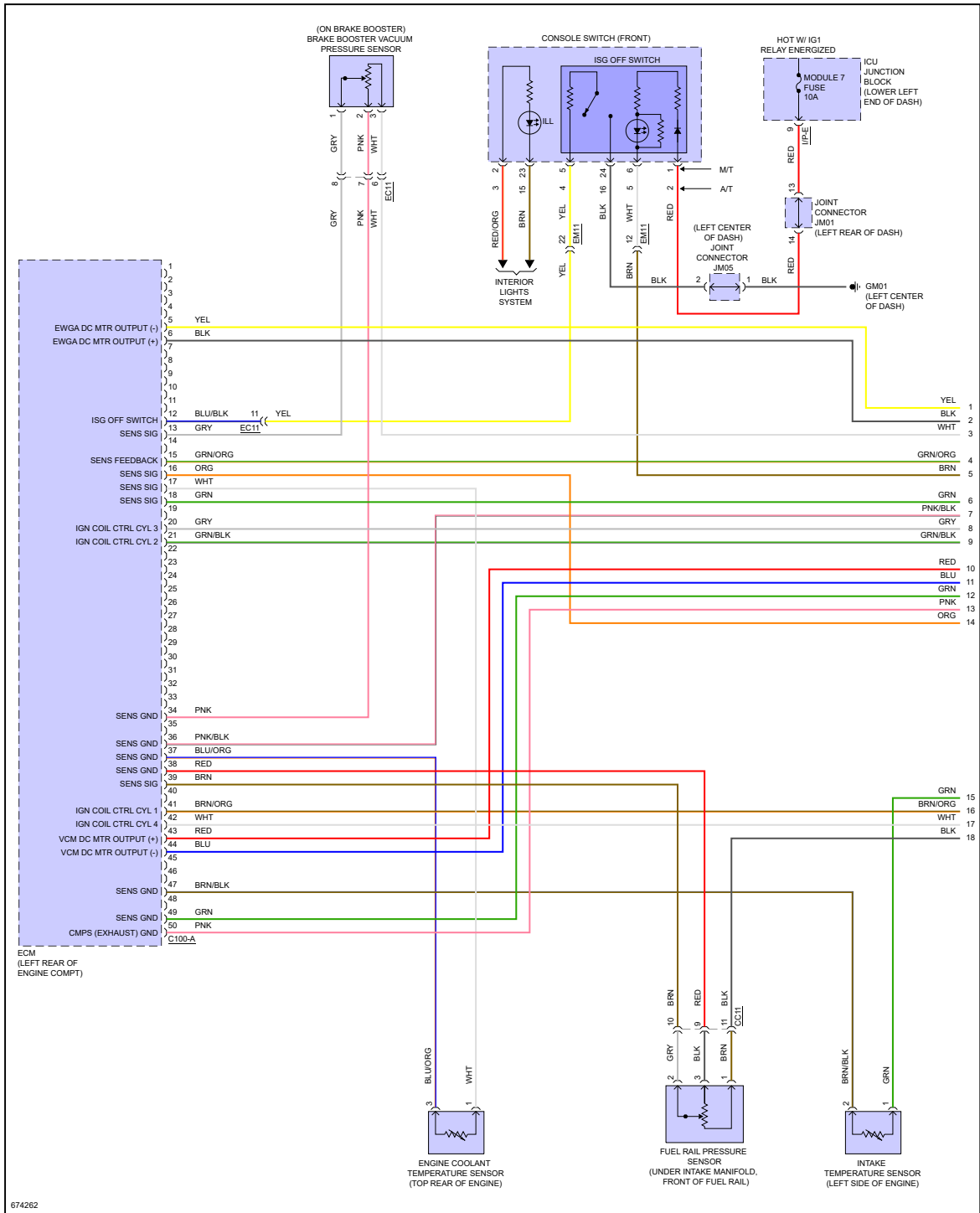

Fig 3: 2.0L Turbo, Engine Controls Circuit (2 of 7)

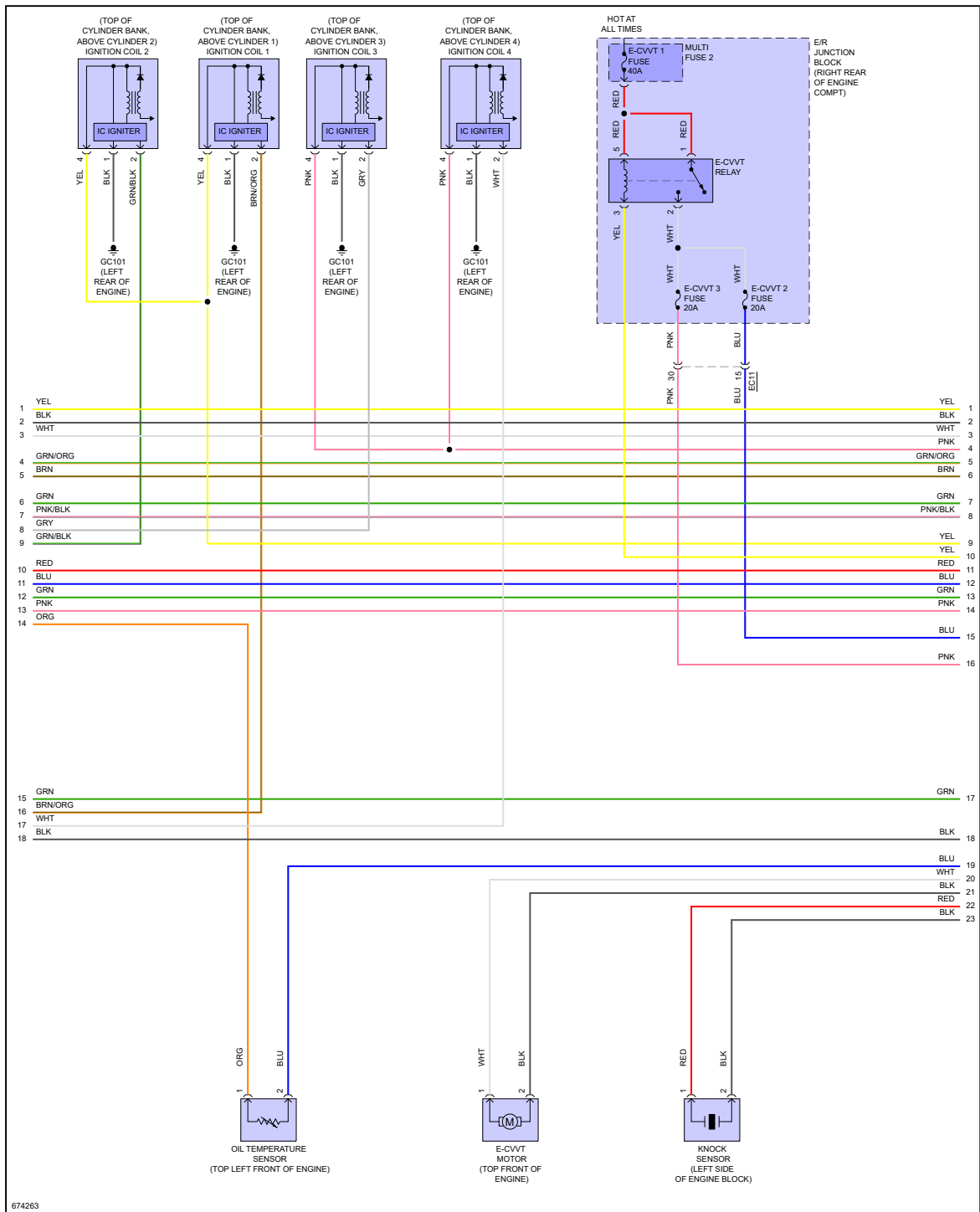

Fig 4: 2.0L Turbo, Engine Controls Circuit (3 of 7)

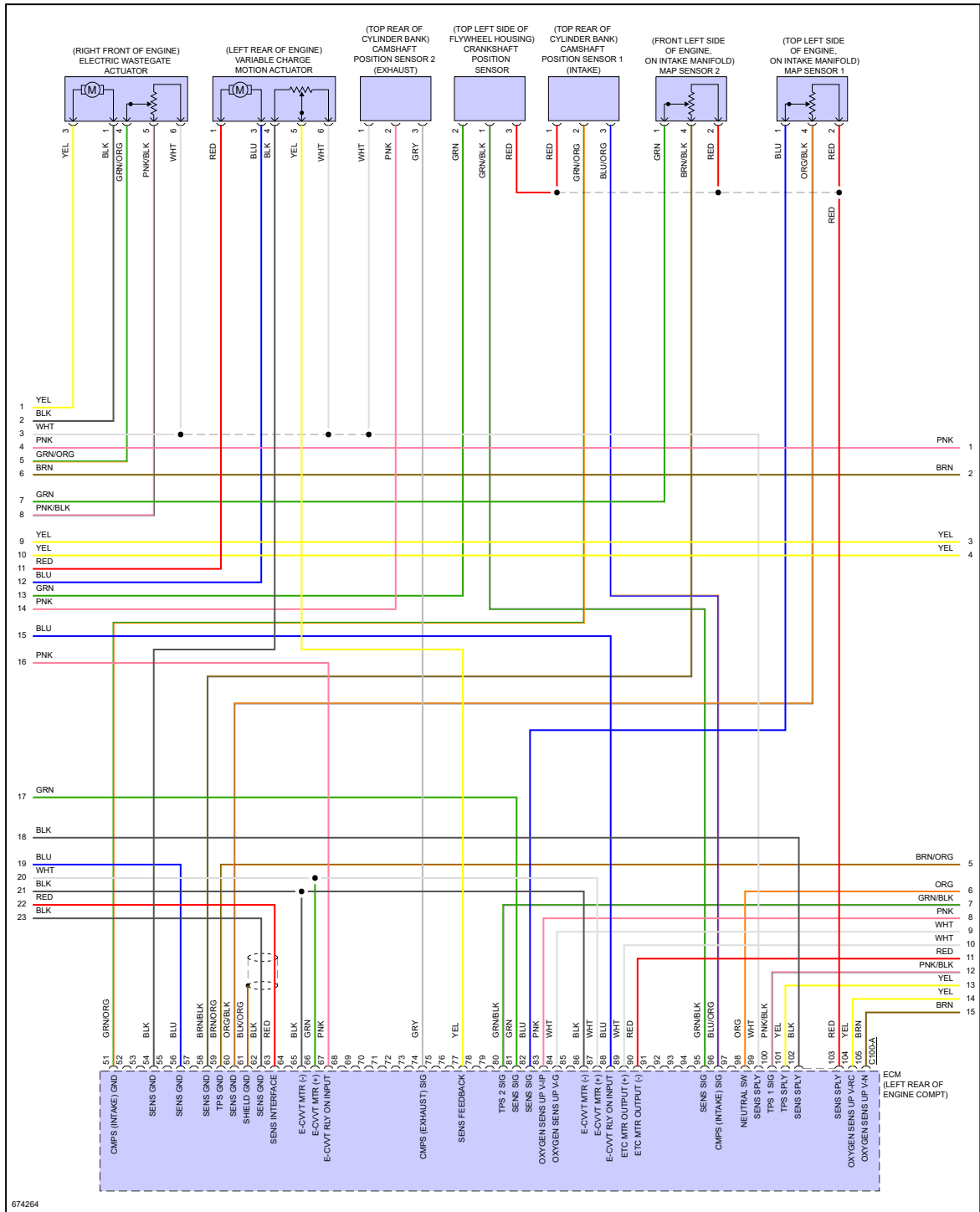

Fig 5: 2.0L Turbo, Engine Controls Circuit (4 of 7)

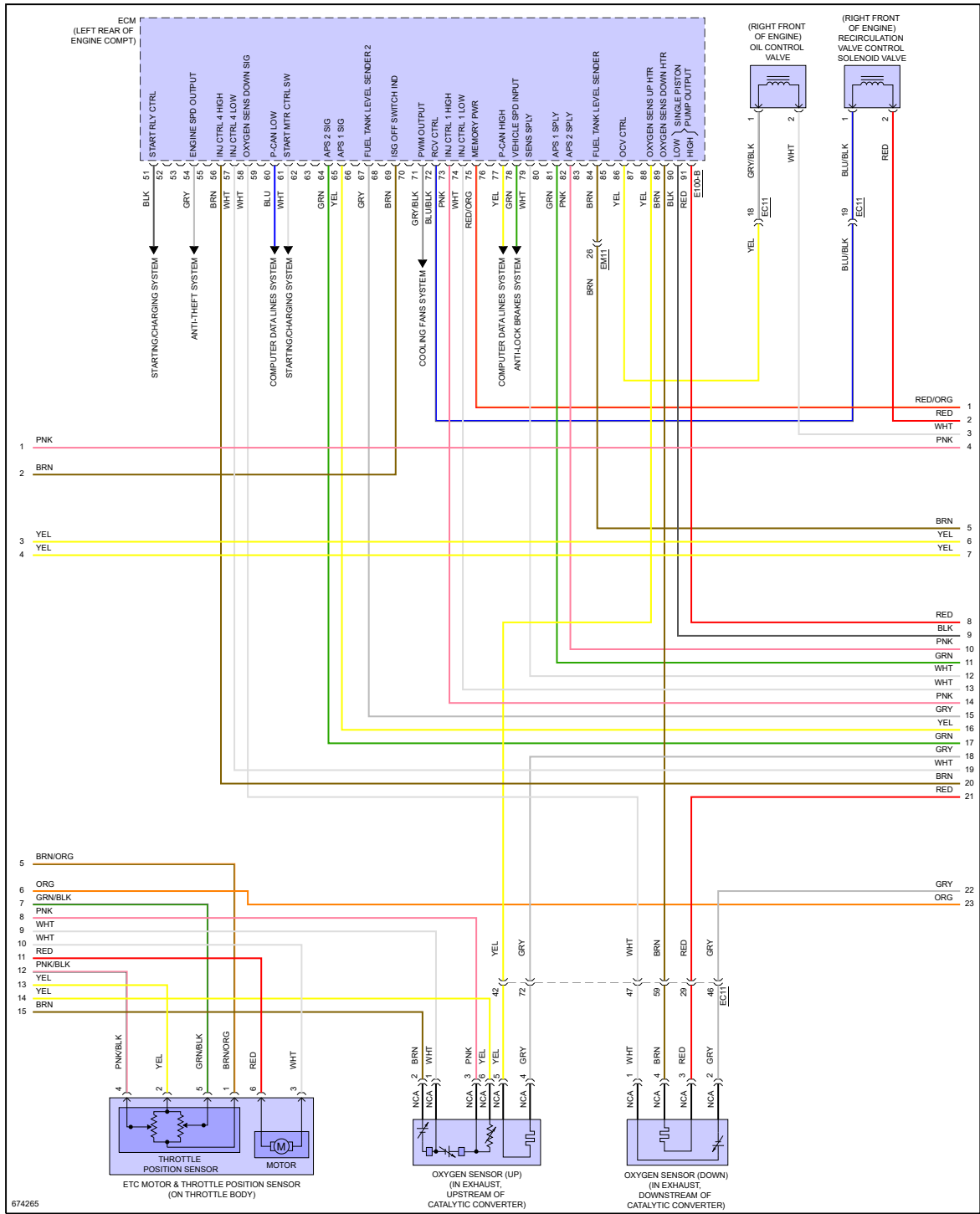

Fig 6: 2.0L Turbo, Engine Controls Circuit (5 of 7)

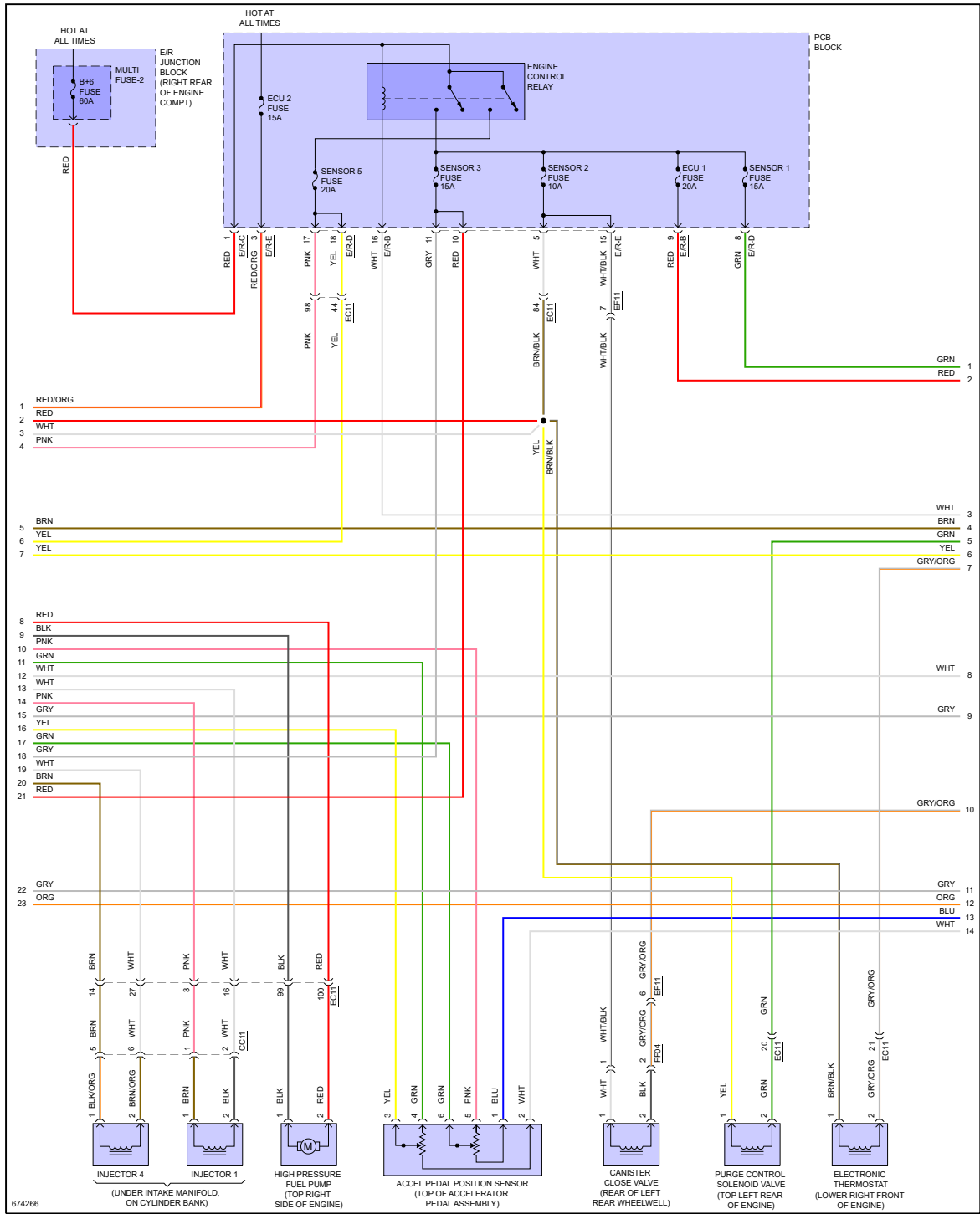

Fig 7: 2.0L Turbo, Engine Controls Circuit (6 of 7)

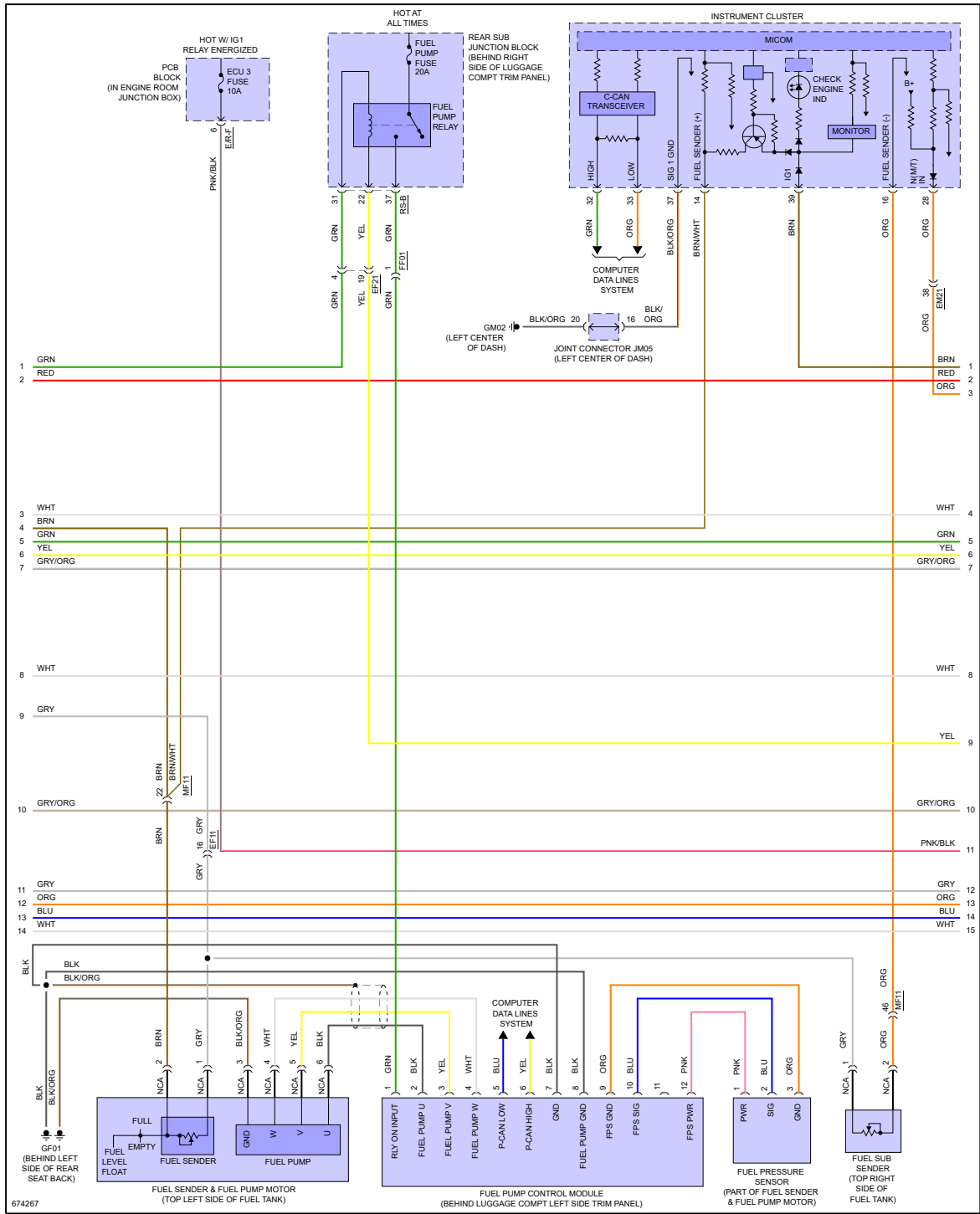
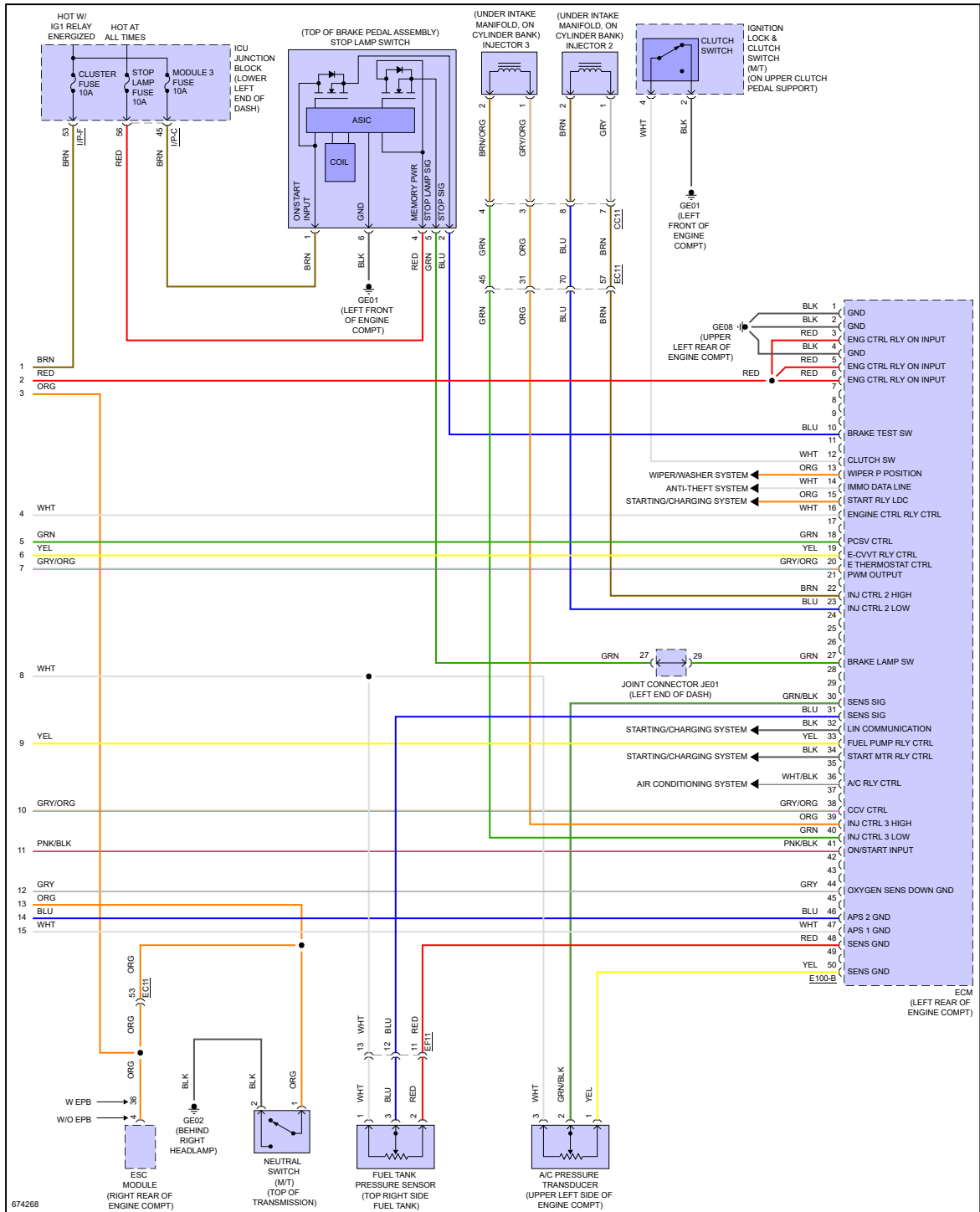



Fig 8: 2.0L Turbo, Engine Controls Circuit (7 of 7)



*"If your car is beat down, bring it to P-Town!"*