

P-Town Auto & Offroad, LLC

688 Harshaw Ave.
Patagonia, AZ 85624
(520) 394-0181 T

YMMS: 2020 Honda Accord EX-L

Engine: 1.5L Eng

VIN:

Aug 1, 2024

License:

Odometer:

ENGINE PERFORMANCE > 1.5L TURBO

Fig 2: 1.5L Turbo, Engine Performance Circuit (2 of 6)

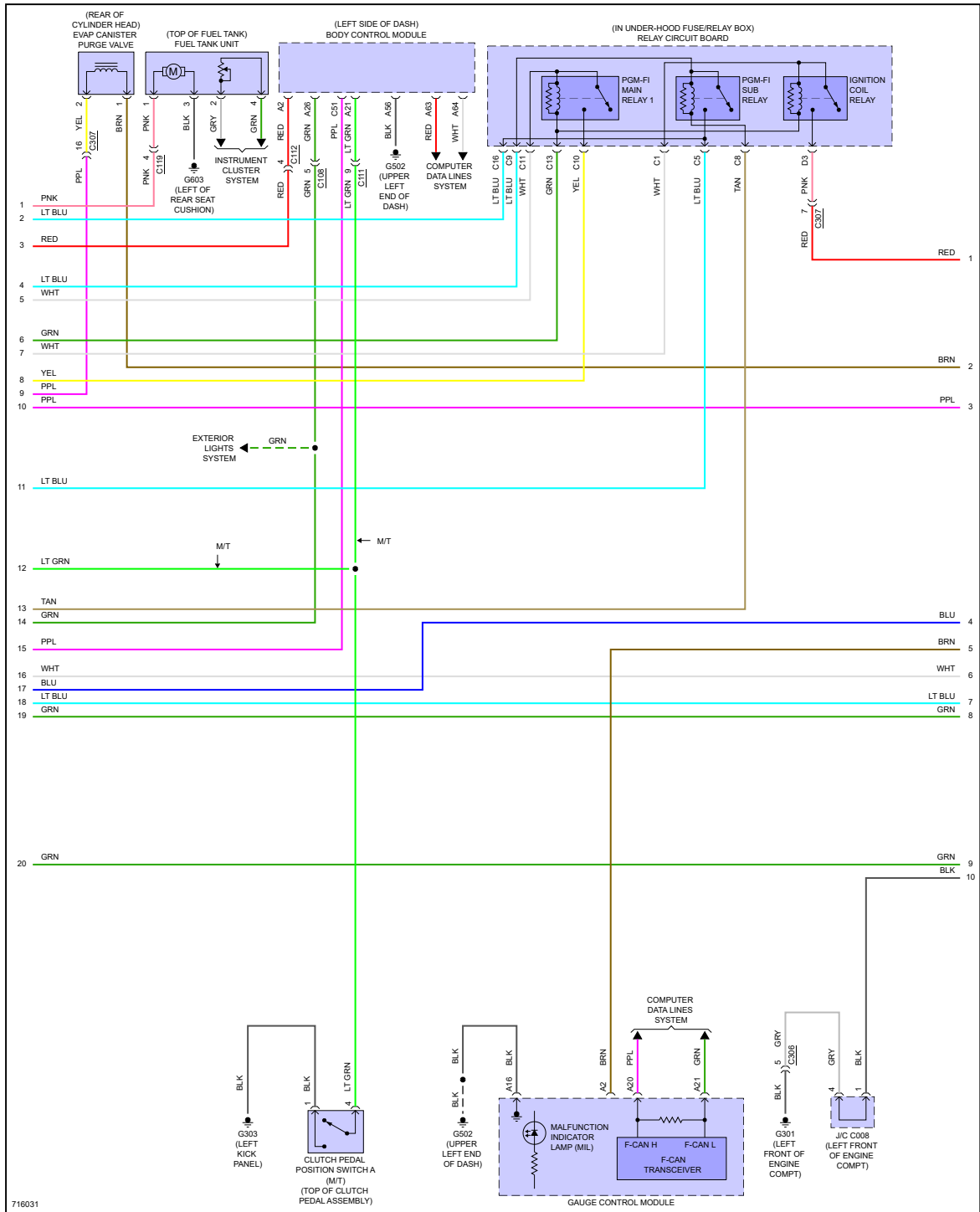

Fig 3: 1.5L Turbo, Engine Performance Circuit (3 of 6)

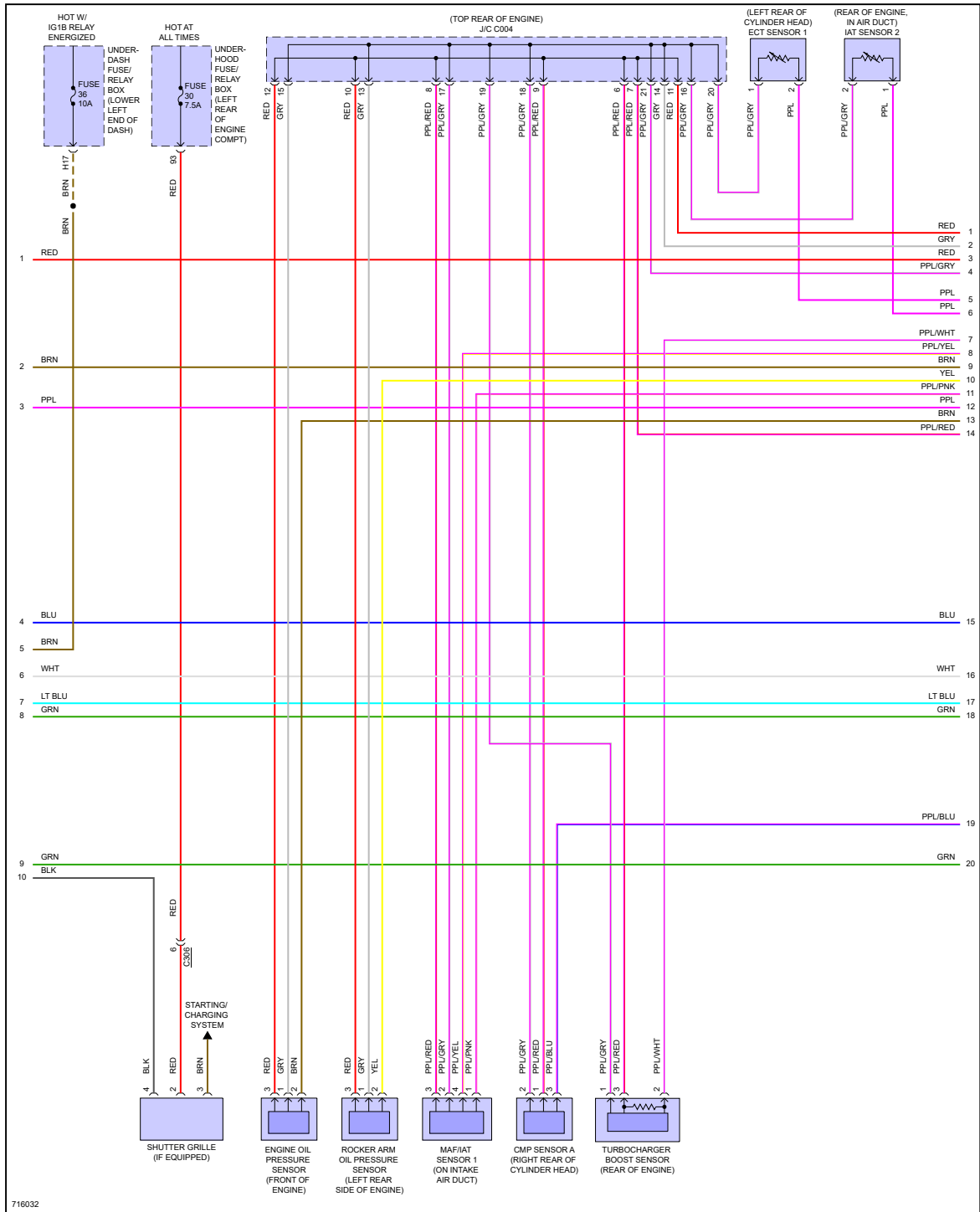

Fig 4: 1.5L Turbo, Engine Performance Circuit (4 of 6)

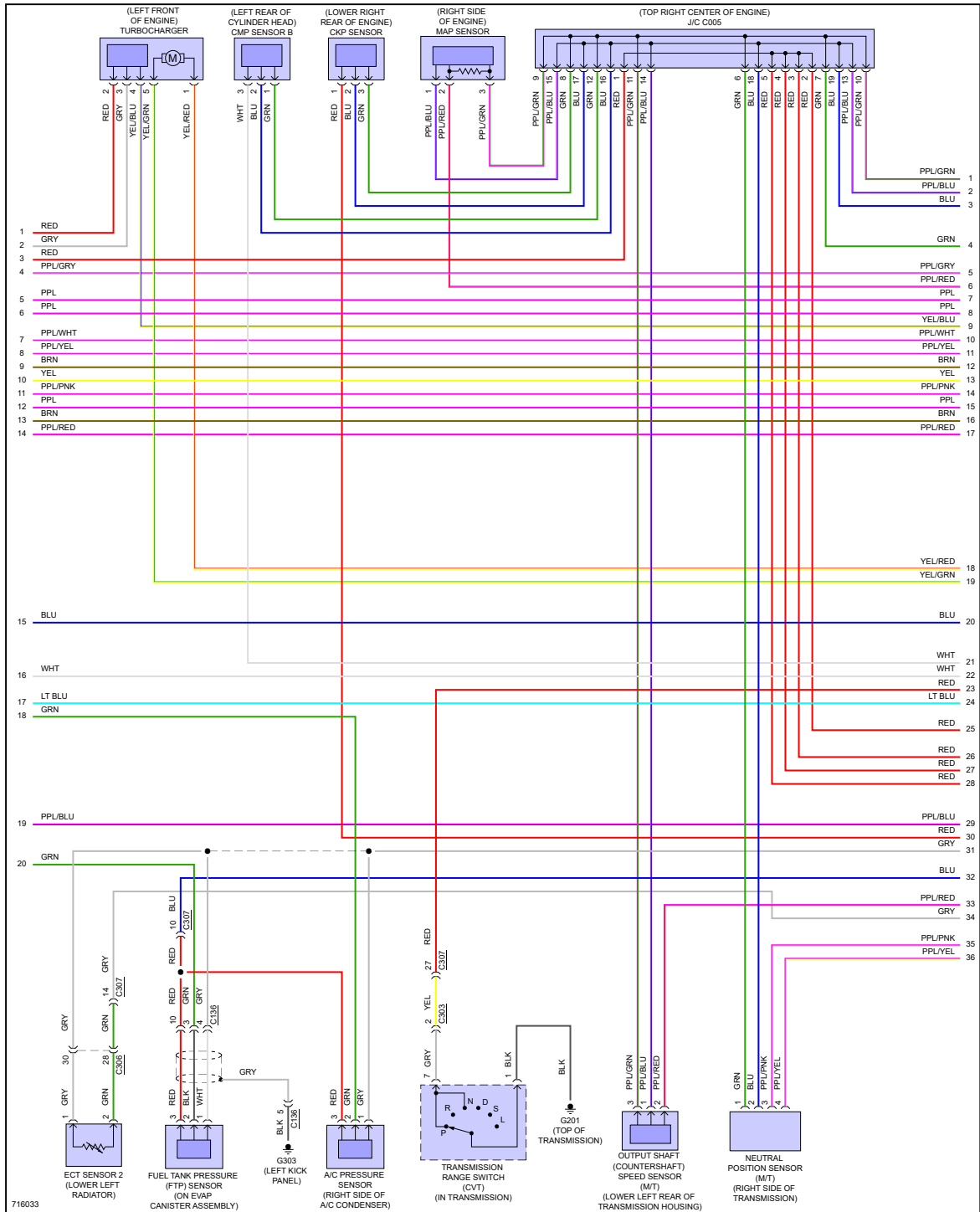

Fig 5: 1.5L Turbo, Engine Performance Circuit (5 of 6)

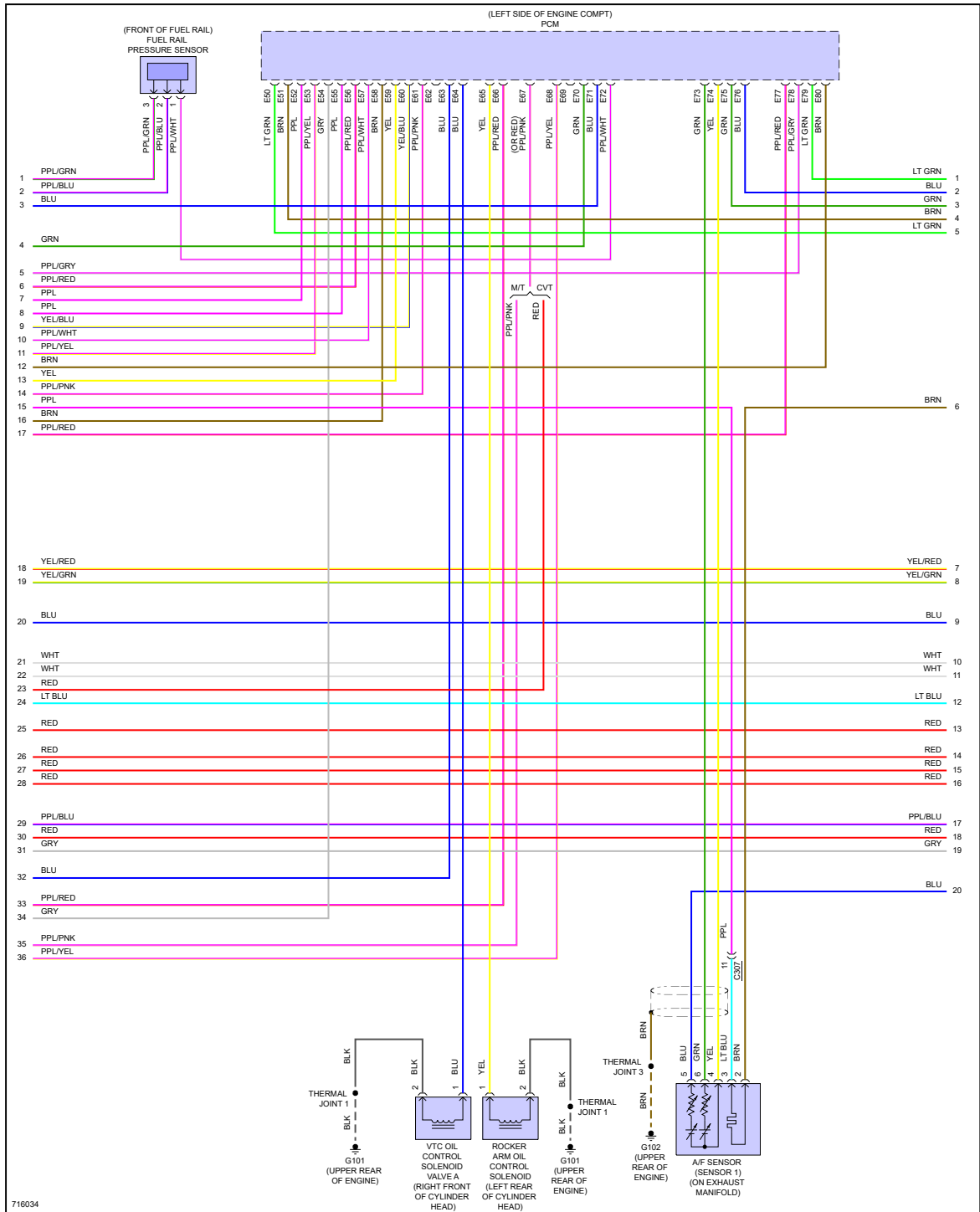
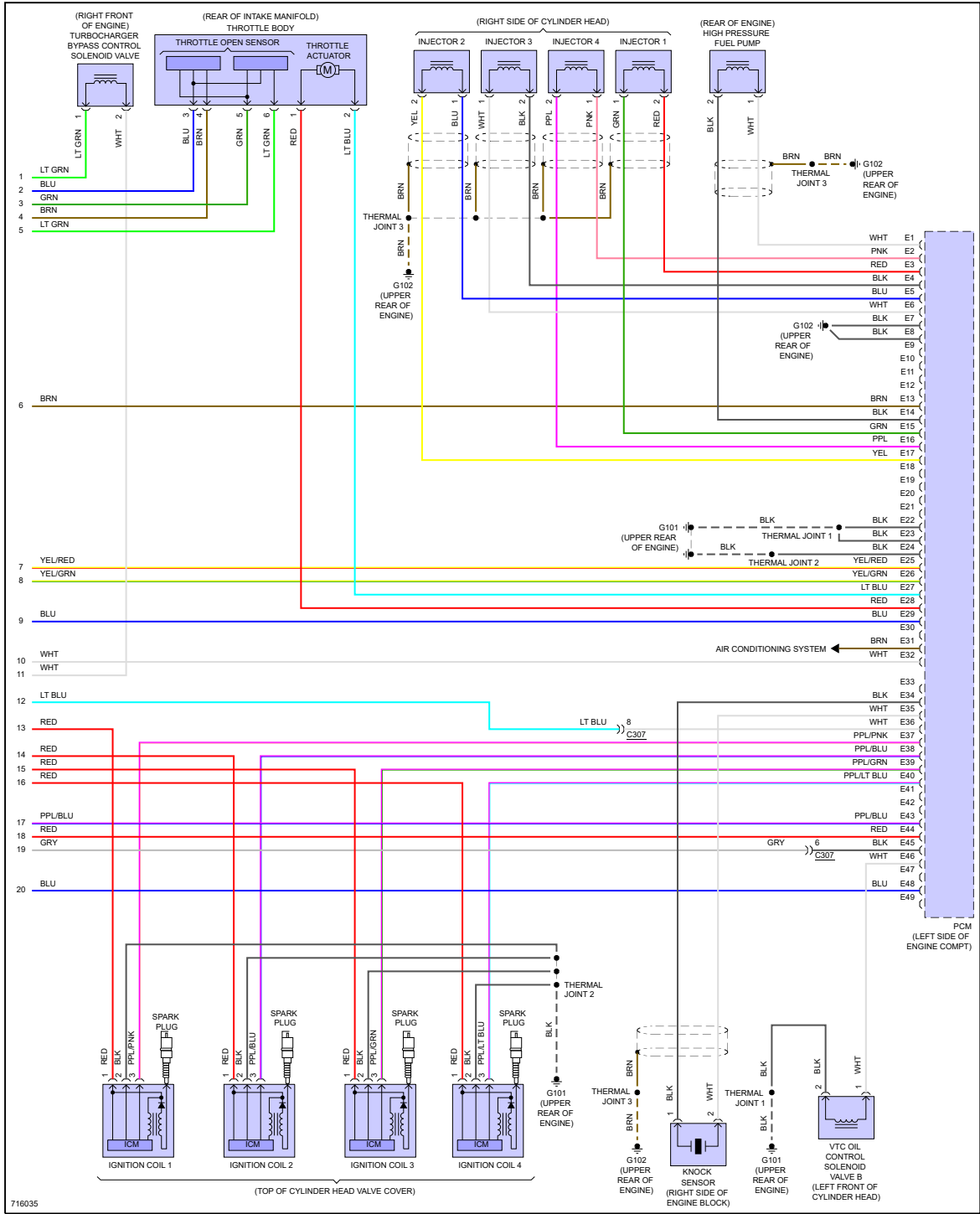

Fig 6: 1.5L Turbo, Engine Performance Circuit (6 of 6)



"If your car is beat down, bring it to P-Town!"