

P-Town Auto & Offroad, LLC

688 Harshaw Ave.
Patagonia, AZ 85624
(520) 394-0181 T

YMMS: 2020 Hyundai Veloster N Base

Engine: 2.0L Eng

VIN:

Sep 1, 2024

License:

Odometer:

ENGINE PERFORMANCE > 2.0L TURBO

Fig 1: 2.0L Turbo, MFI Control Circuit (1 of 7)

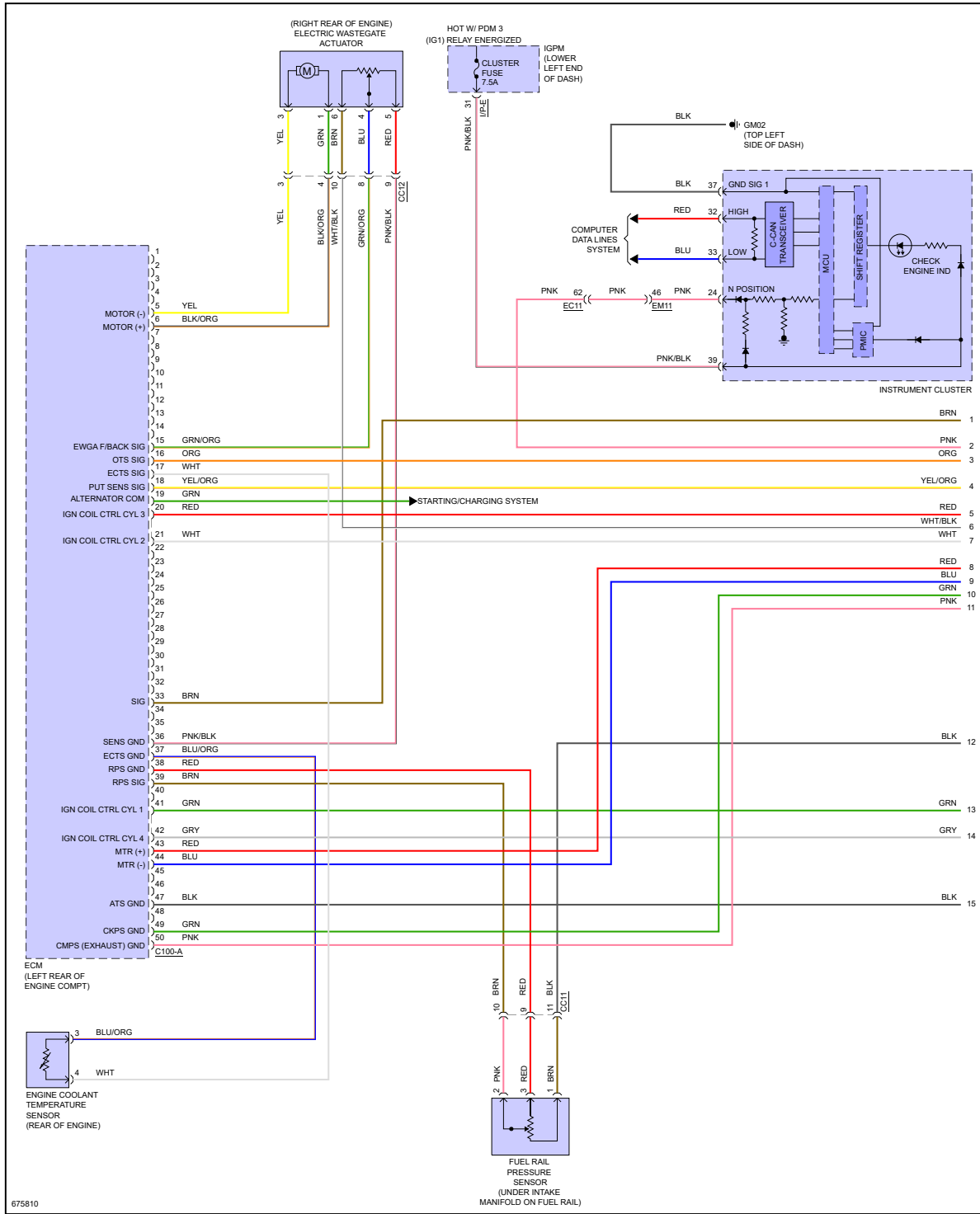

Fig 2: 2.0L Turbo, MFI Control Circuit (2 of 7)

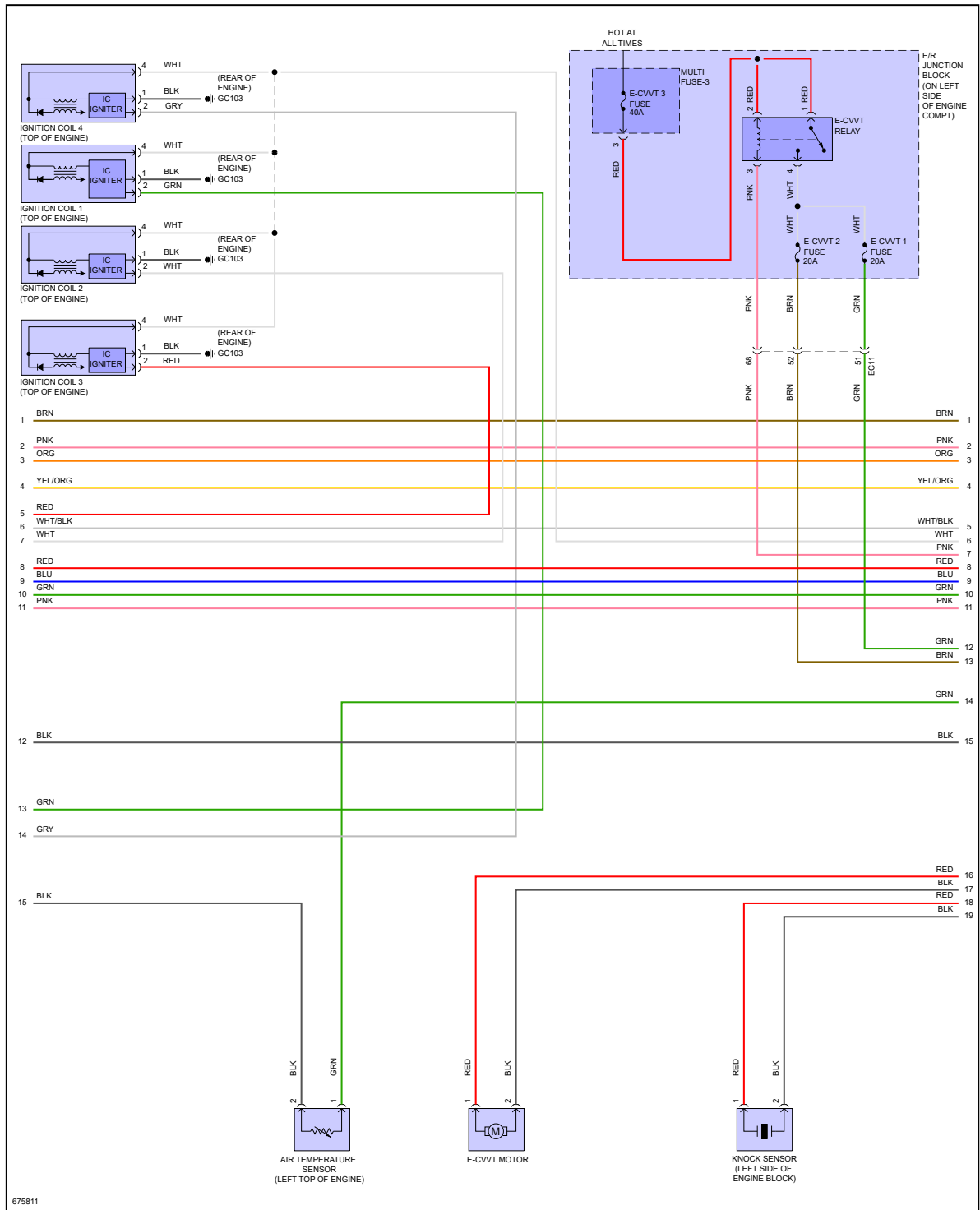

Fig 3: 2.0L Turbo, MFI Control Circuit (3 of 7)

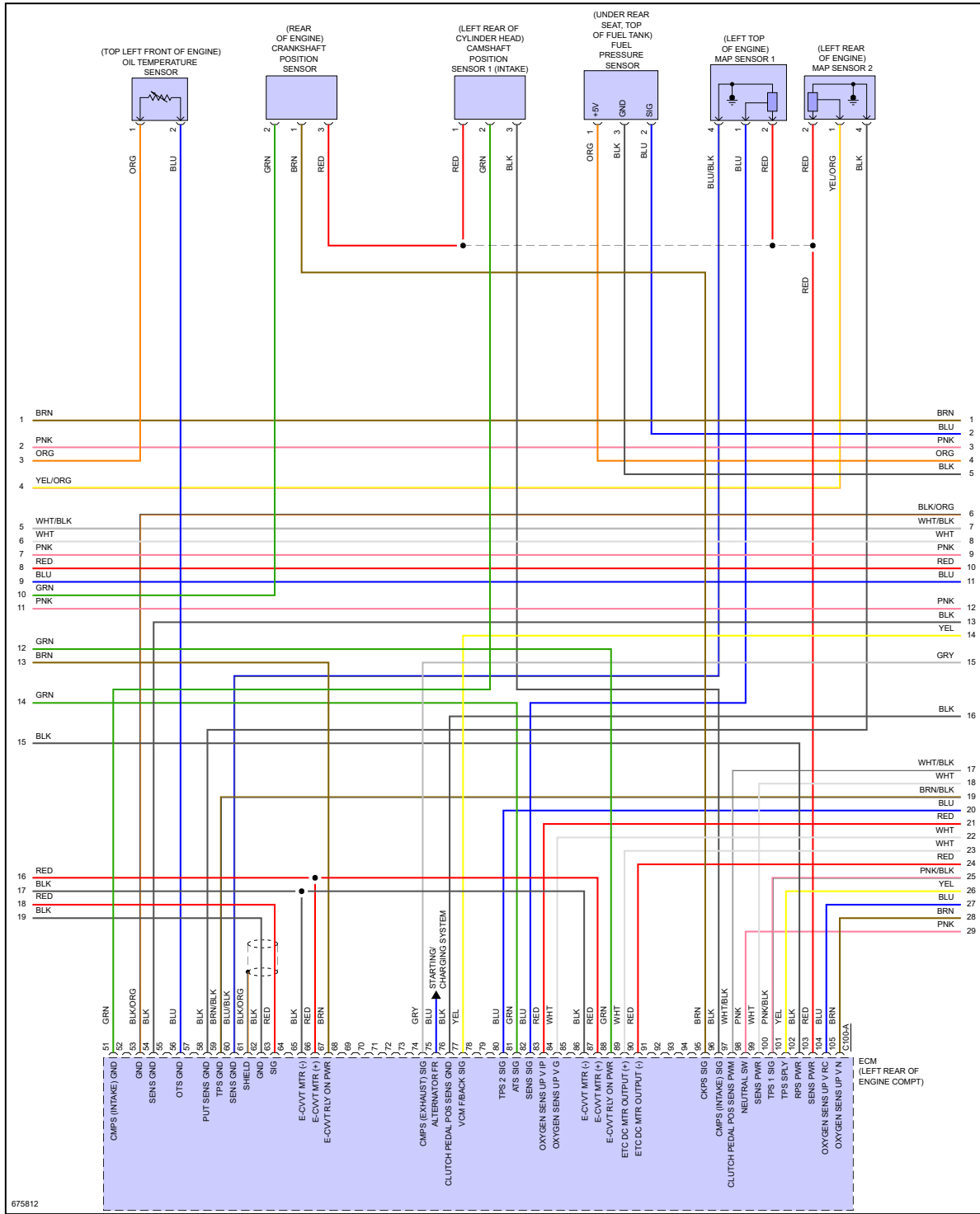

Fig 4: 2.0L Turbo, MFI Control Circuit (4 of 7)

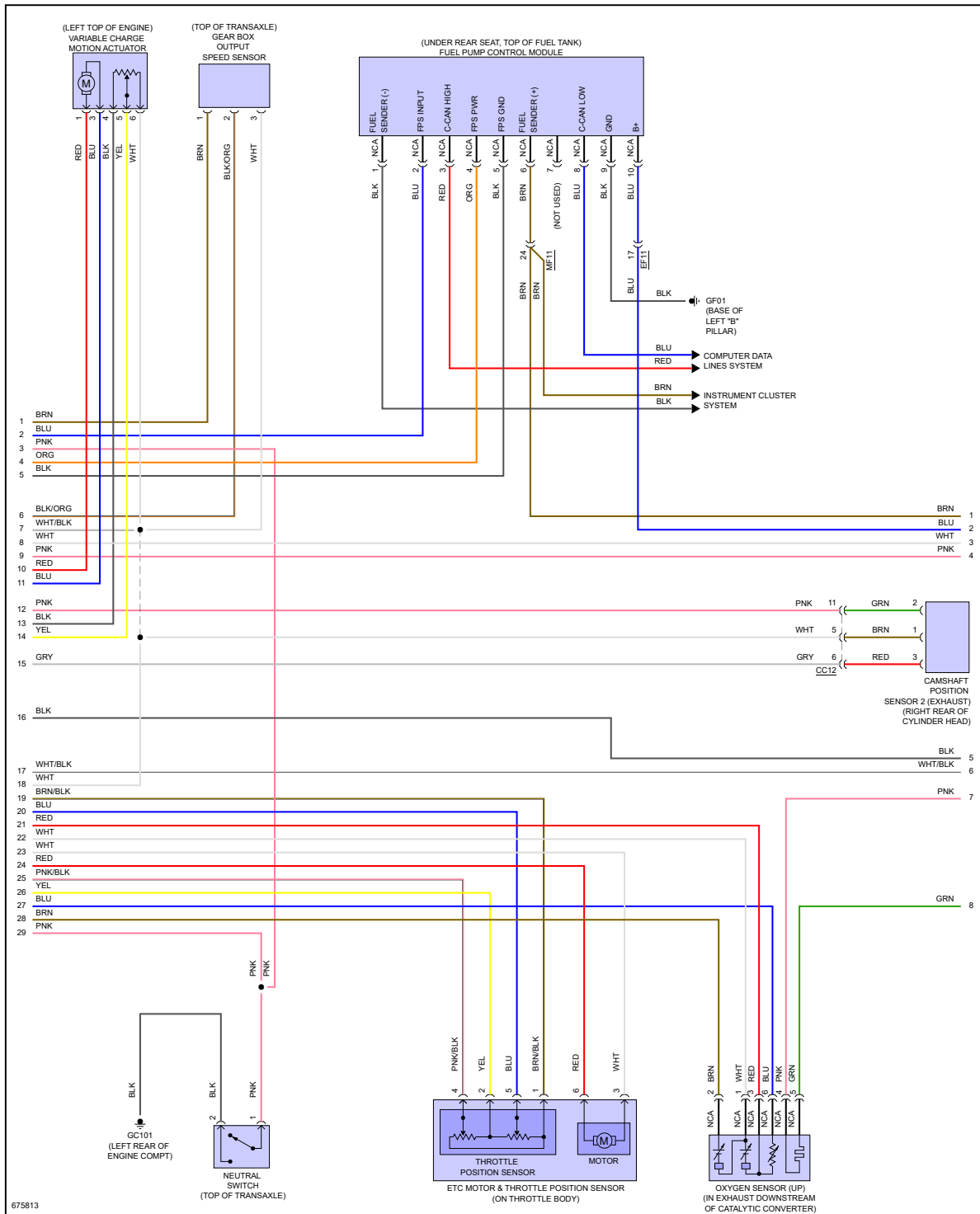

Fig 5: 2.0L Turbo, MFI Control Circuit (5 of 7)

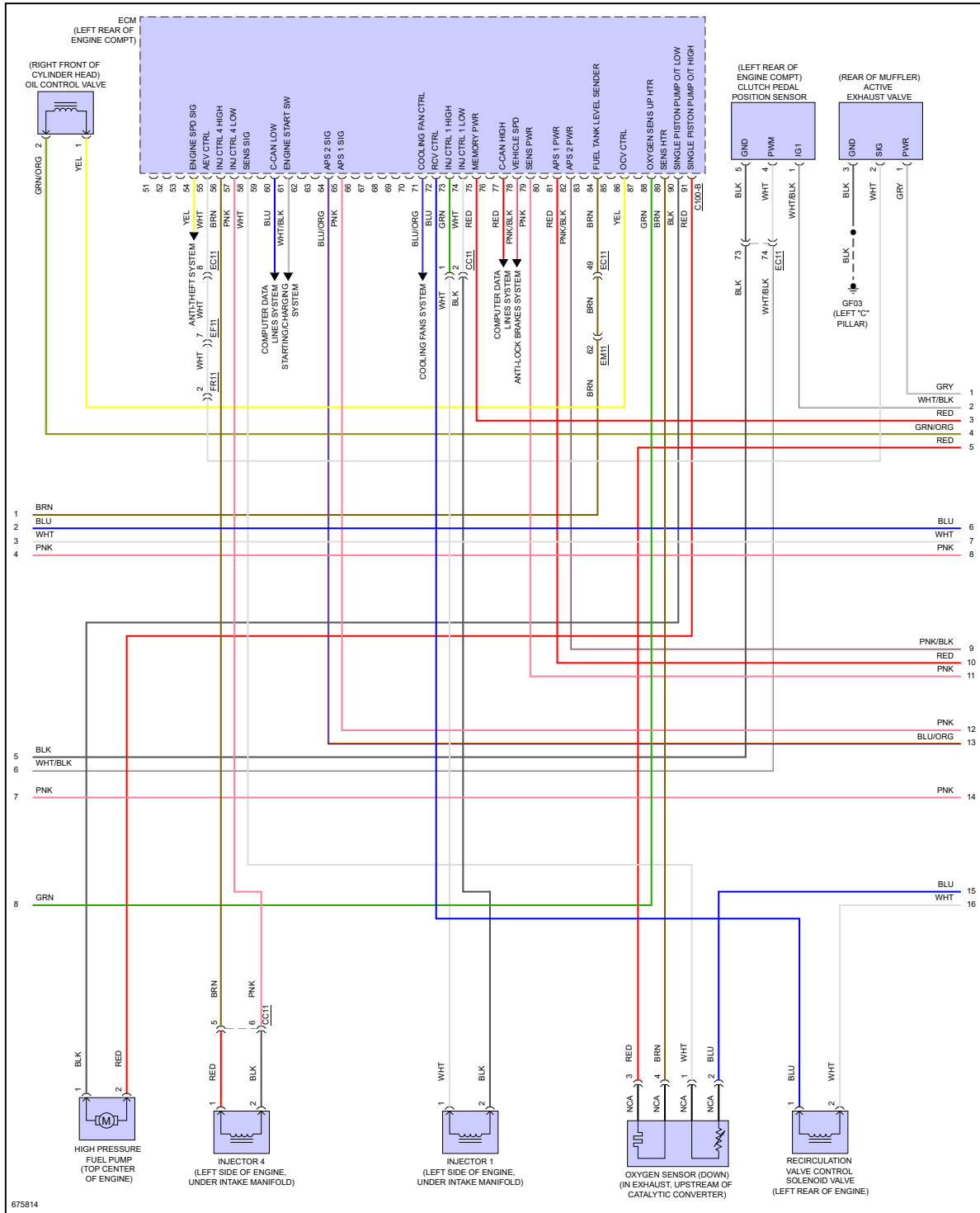

Fig 6: 2.0L Turbo, MFI Control Circuit (6 of 7)

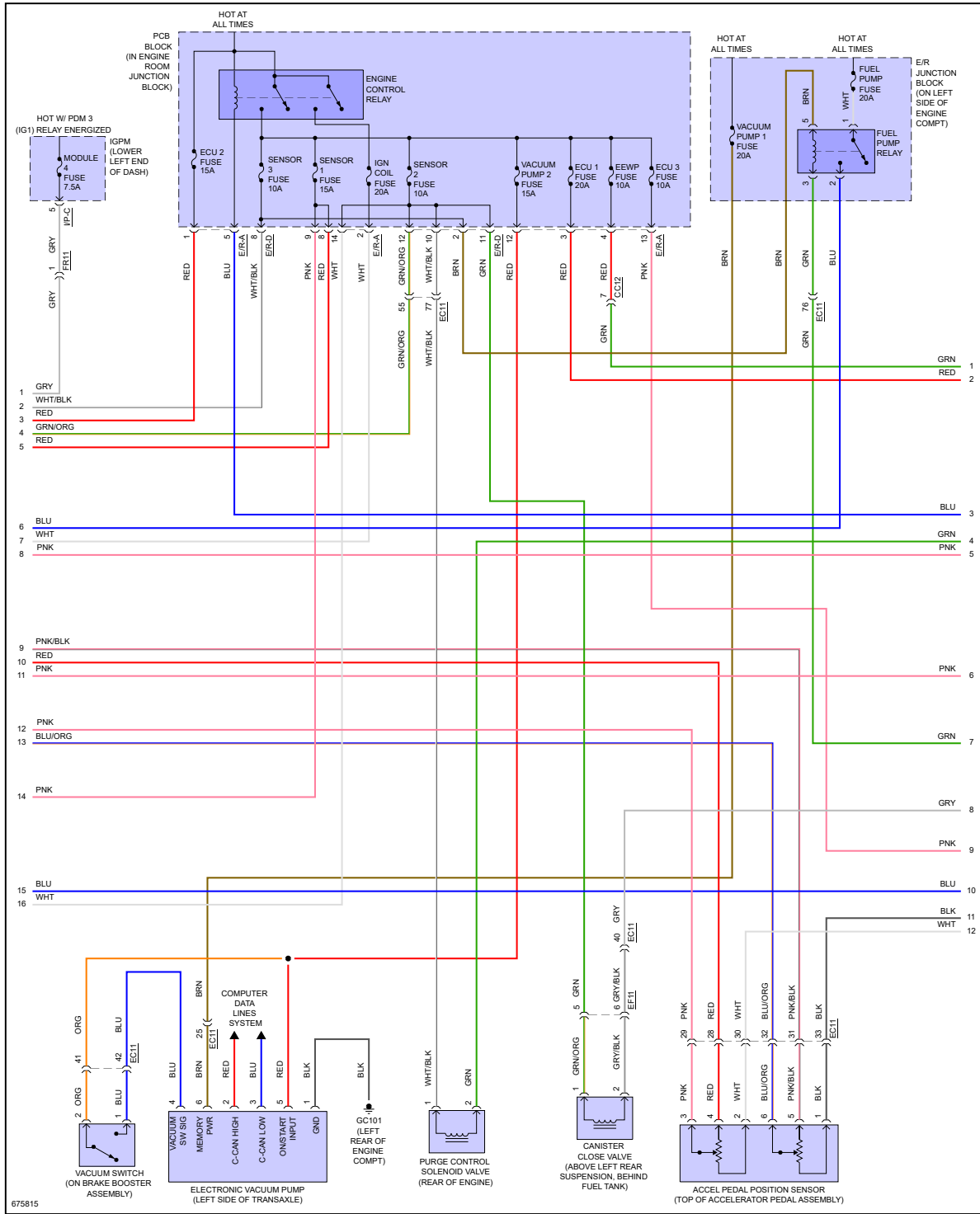

Fig 7: 2.0L Turbo, MFI Control Circuit (7 of 7)

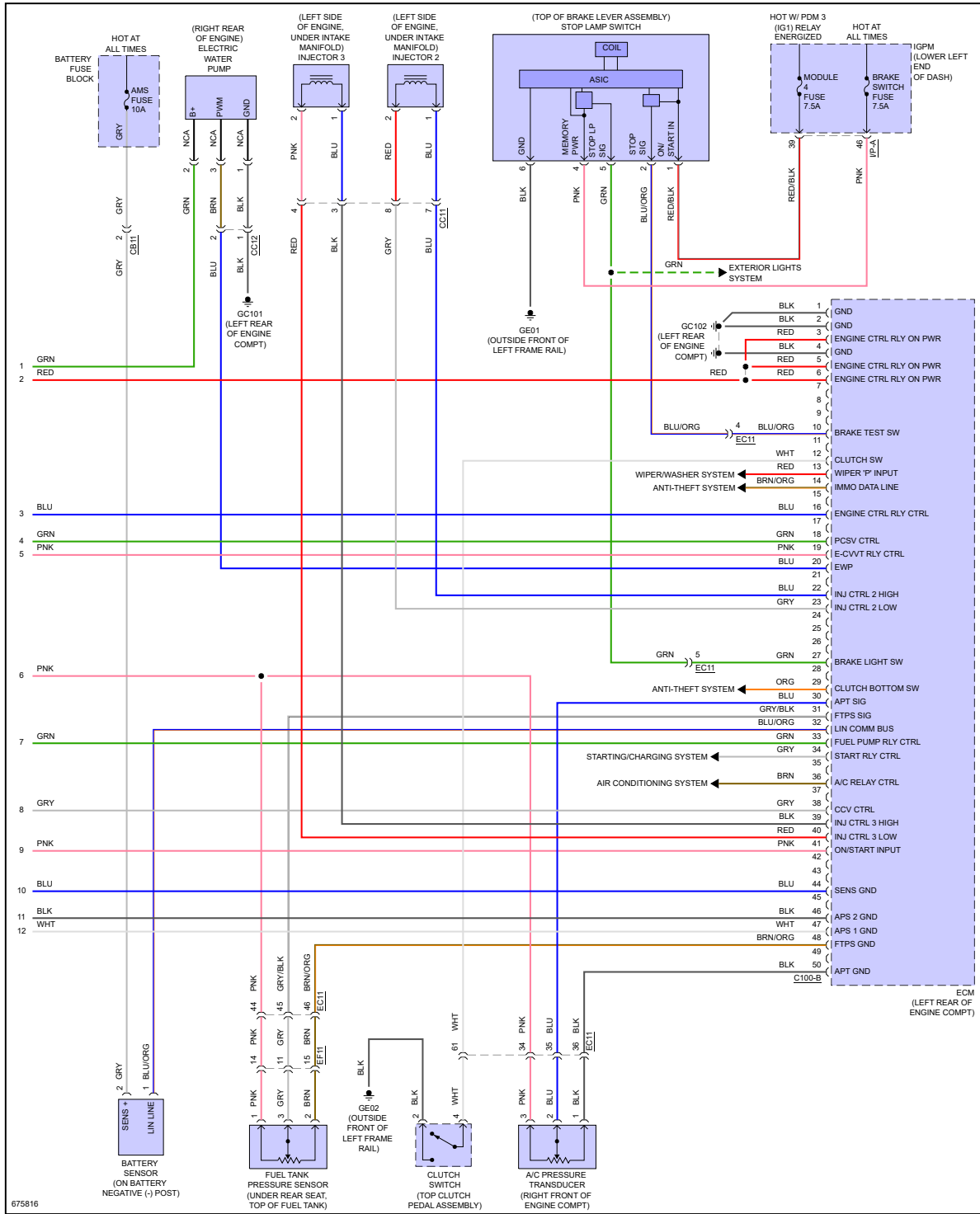
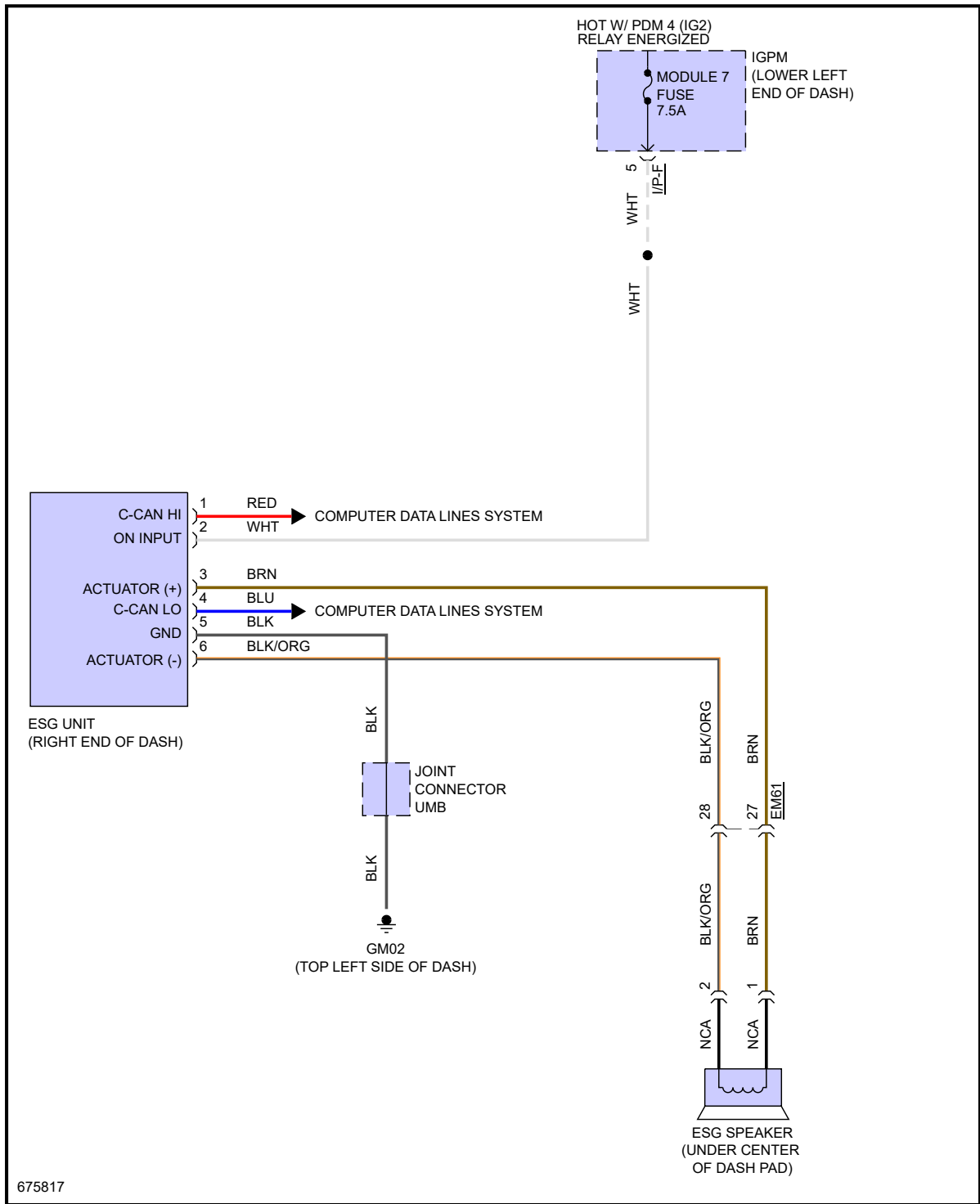

Fig 8: 2.0L Turbo, Virtual Engine Sound System Circuit



"If your car is beat down, bring it to P-Town!"