

P-Town Auto & Offroad, LLC

688 Harshaw Ave.
Patagonia, AZ 85624
(520) 394-0181 T

YMMS: 2023 Hyundai Elantra SE
Engine: 2.0L Eng
VIN:

Apr 16, 2024
License:
Odometer:

ENGINE PERFORMANCE > 2.0L

Fig 1: 2.0L, Engine Performance Circuit (1 of 8)

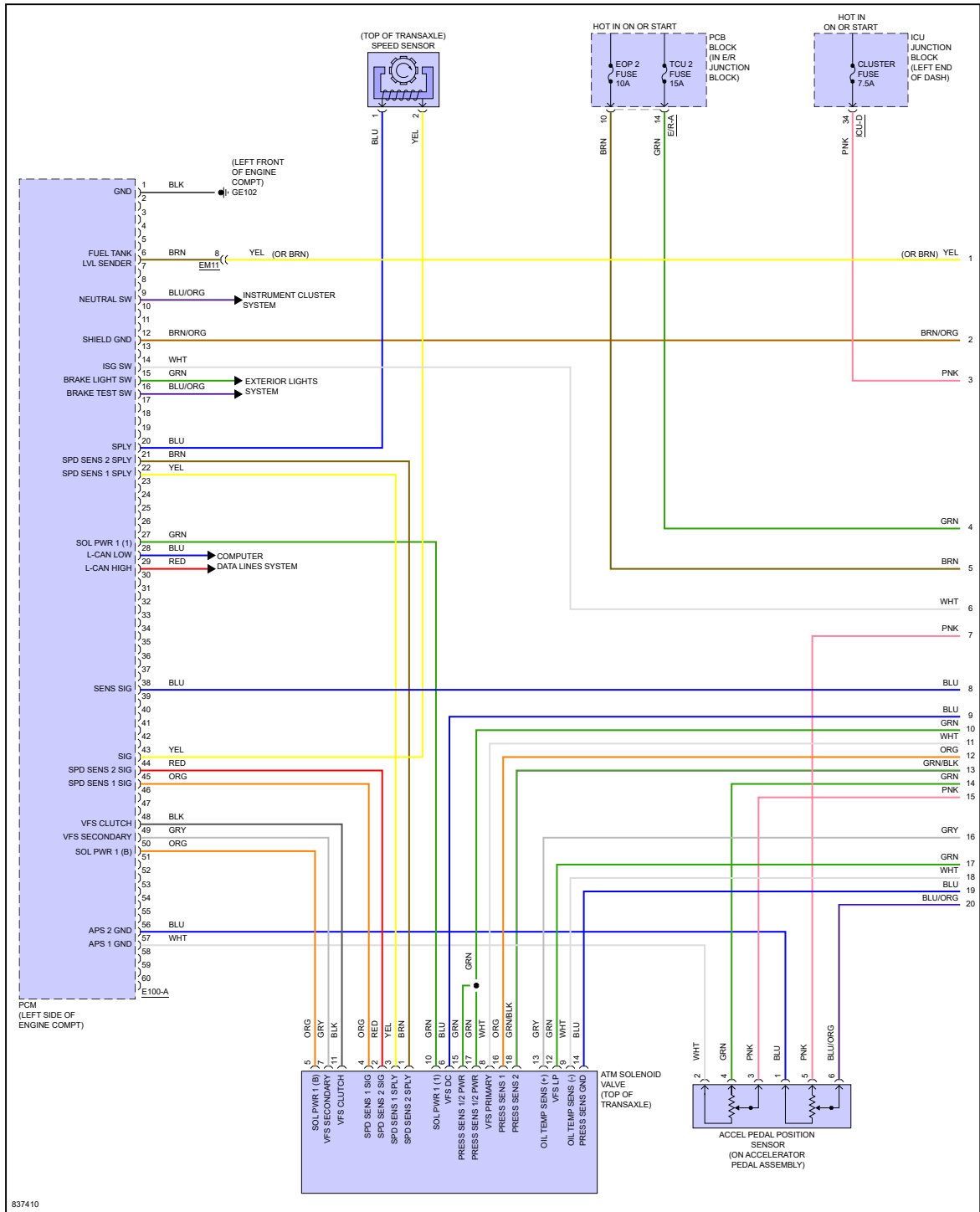

Fig 2: 2.0L, Engine Performance Circuit (2 of 8)

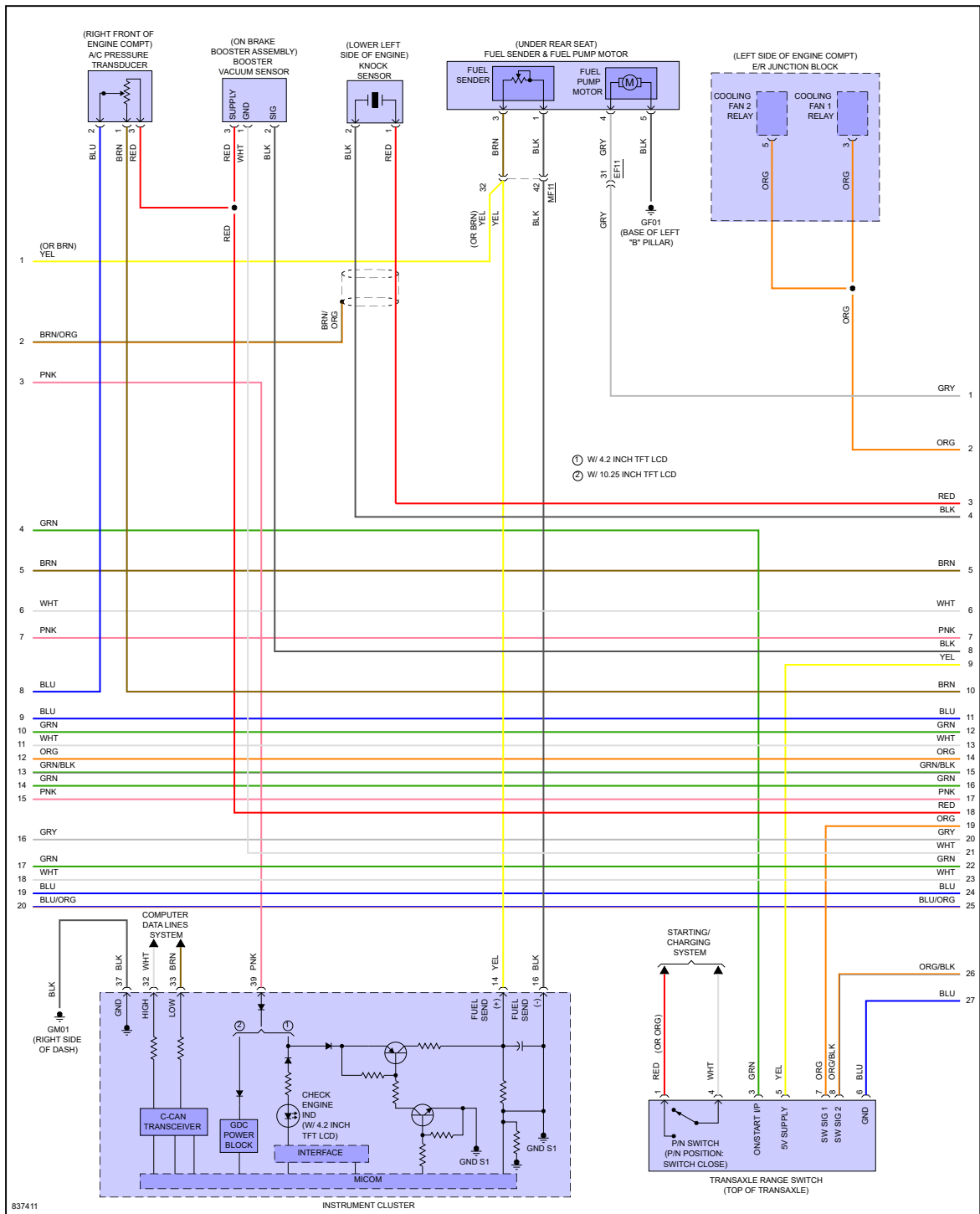

Fig 4: 2.0L, Engine Performance Circuit (4 of 8)

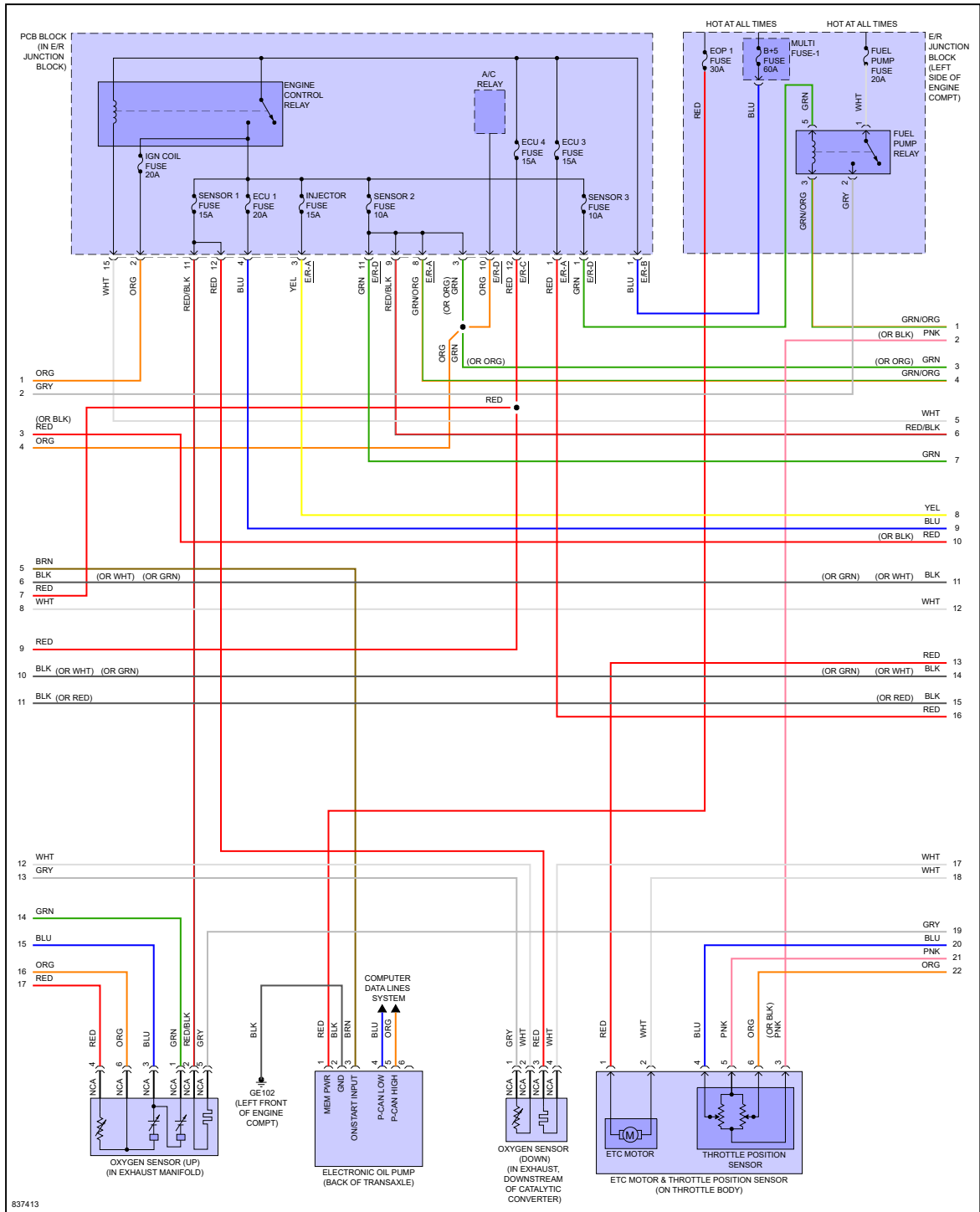

Fig 5: 2.0L, Engine Performance Circuit (5 of 8)

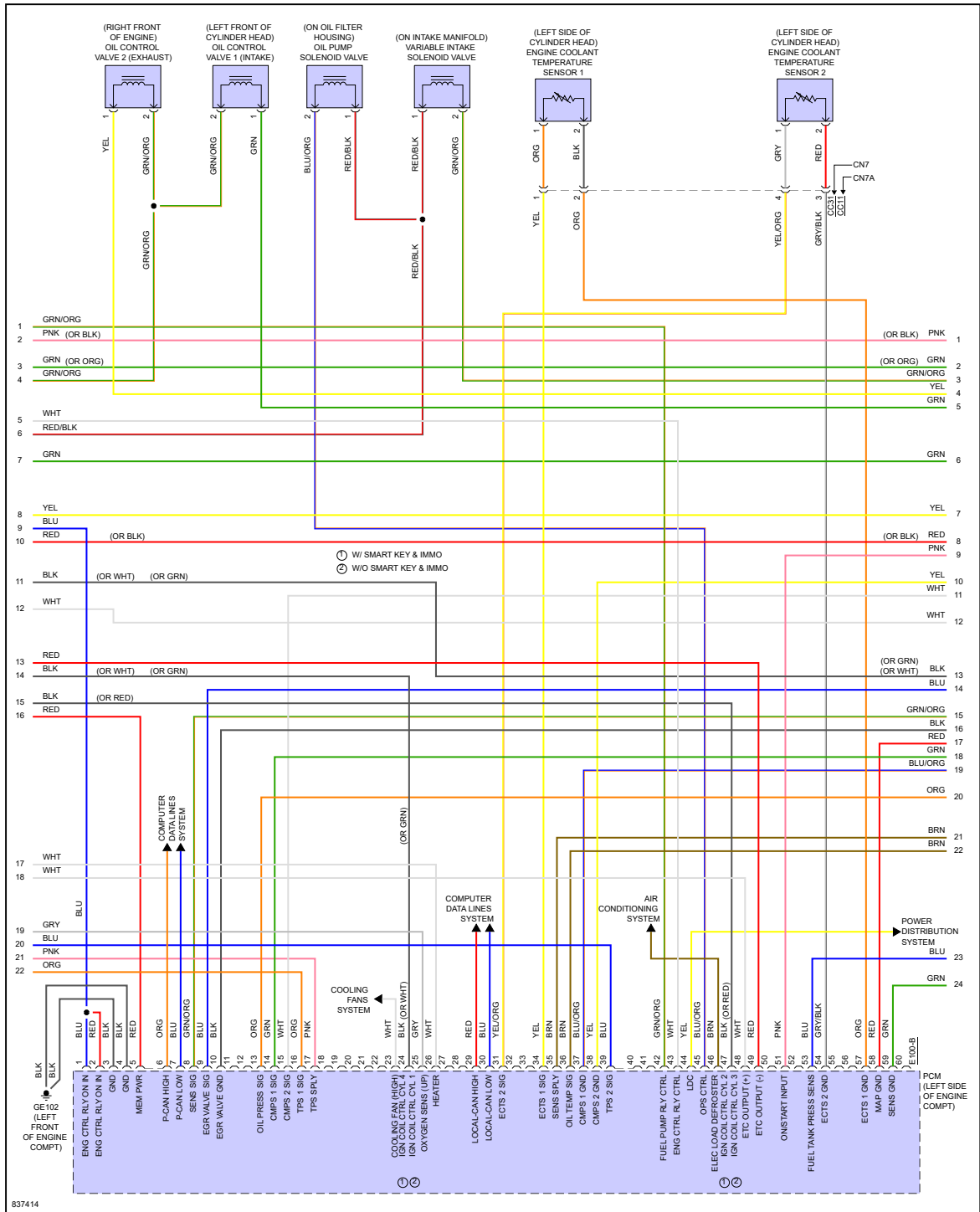

Fig 6: 2.0L, Engine Performance Circuit (6 of 8)

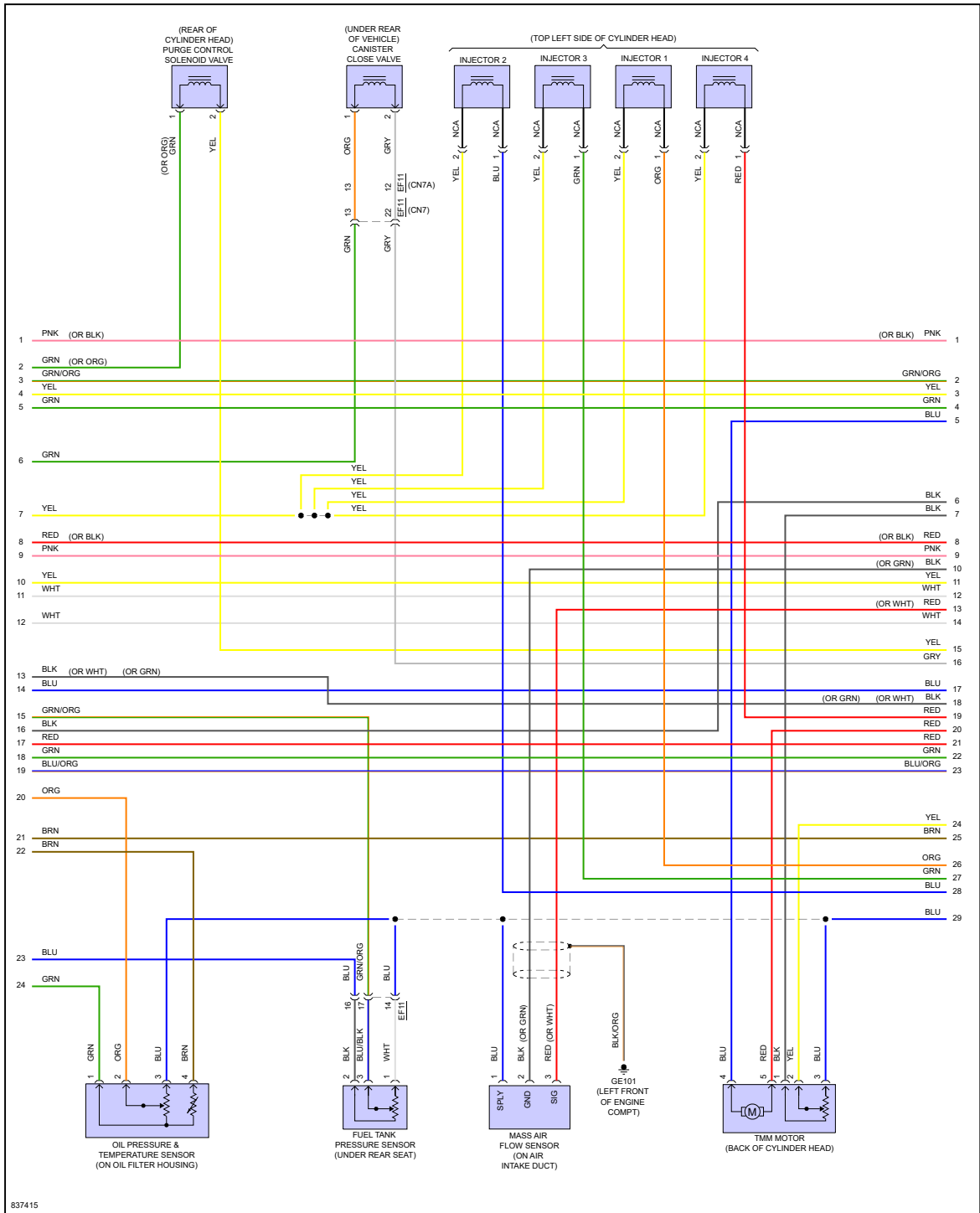

Fig 7: 2.0L, Engine Performance Circuit (7 of 8)

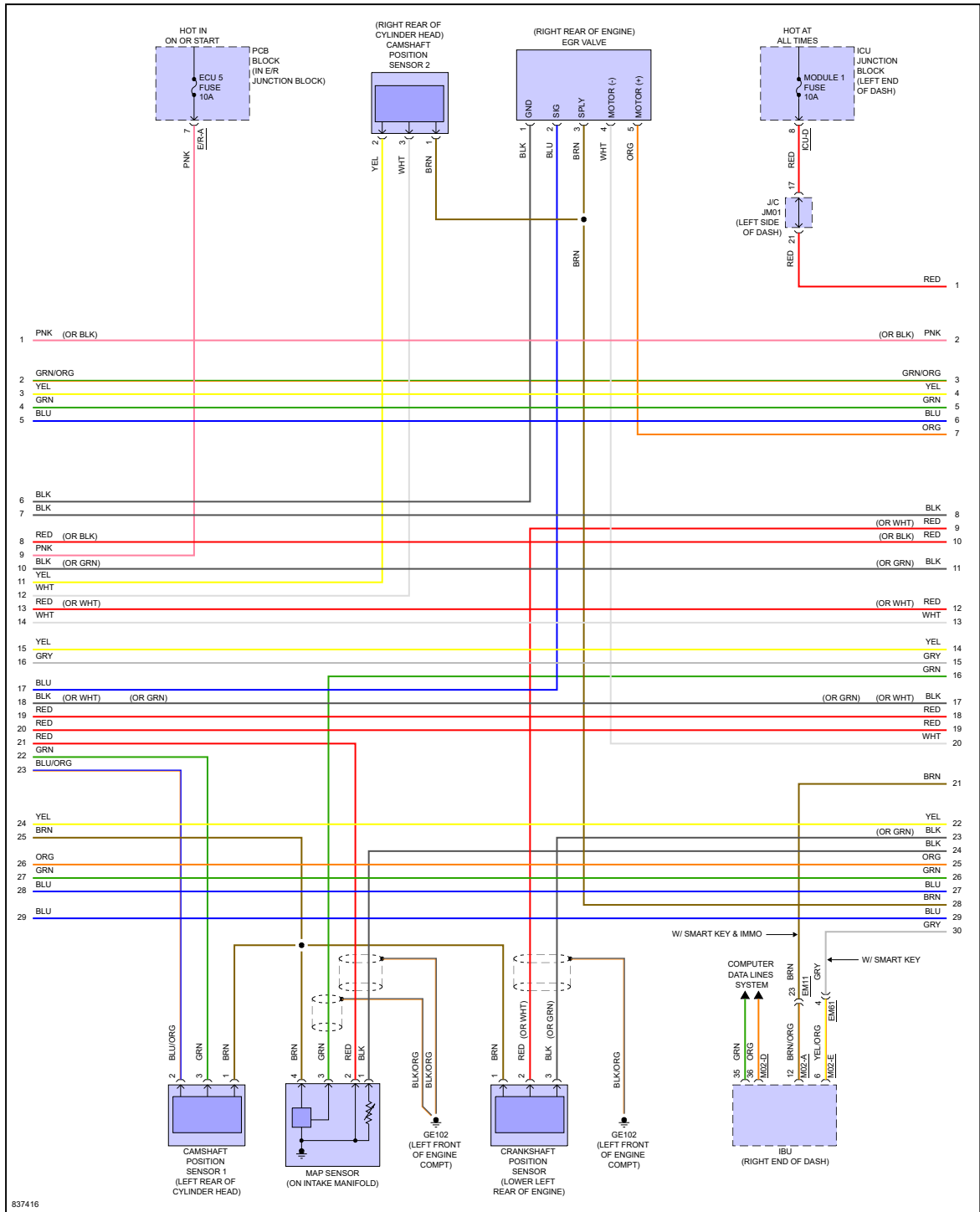
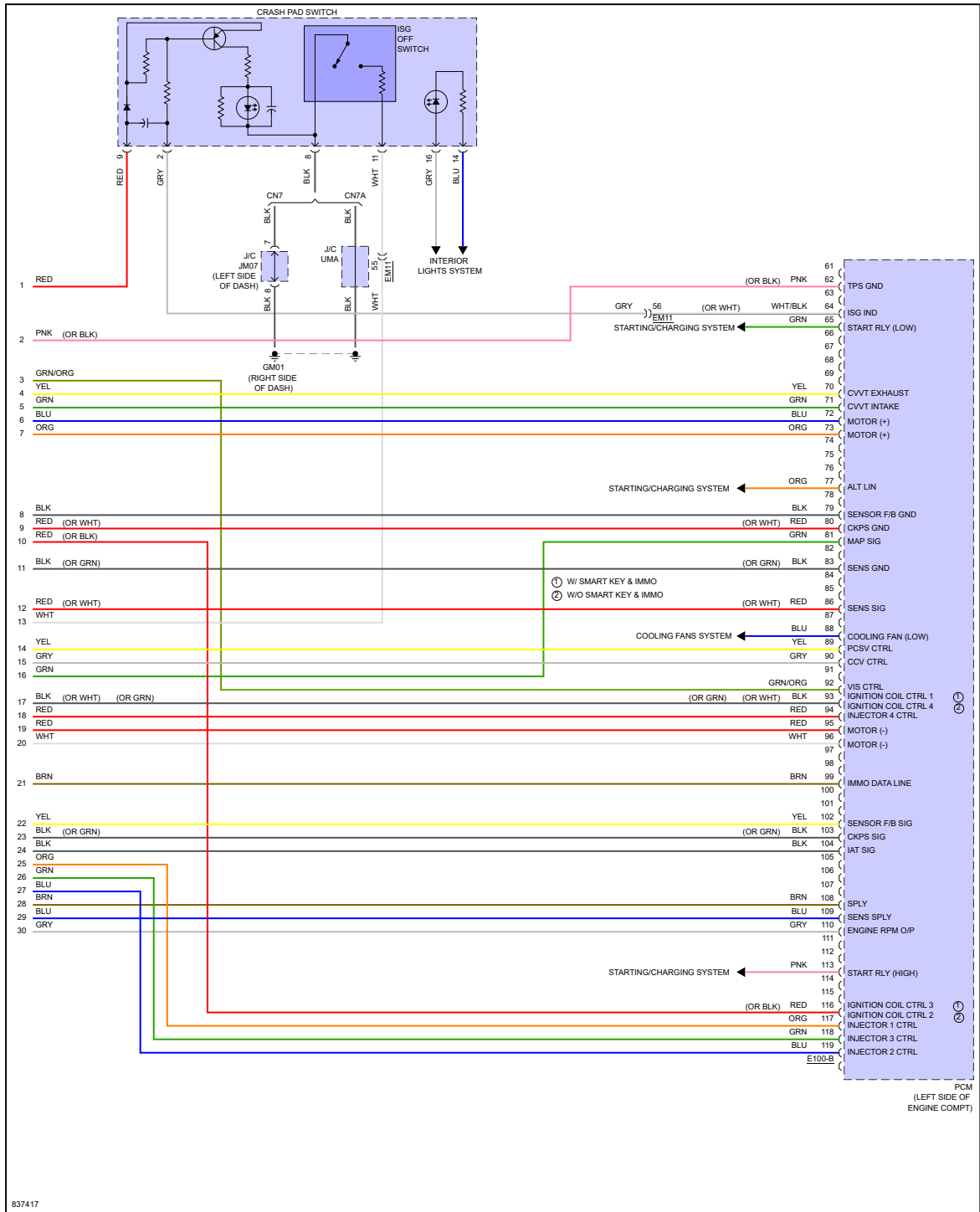

Fig 8: 2.0L, Engine Performance Circuit (8 of 8)



"If your car is beat down, bring it to P-Town!"