



# **POLARIS®**

## **2014 RZR XP / XP 4 1000 Service Manual**

### **FOREWORD**

The information printed within this publication includes the latest product information at time of print. The most recent version of this Service Manual is available in electronic format at [www.polarisdealers.com](http://www.polarisdealers.com).

This Service Manual is designed primarily for use by certified Polaris Master Service Dealer® technicians in a properly equipped shop and should be kept available for reference. All references to left and right side of the vehicle are from the operator's perspective when seated in a normal riding position.

Some procedures outlined in this manual require a sound knowledge of mechanical theory, tool use, and shop procedures in order to perform the work safely and correctly. Technicians should read the text and be familiar with the service procedures before starting any repair. Certain procedures require the use of special tools. Use only the proper tools as specified. If you have any doubt as to your ability to perform any of the procedures outlined in this Service Manual, contact an authorized dealer for service.

We value your input and appreciate any assistance you can provide in helping make these publications more useful. Please provide any feedback you may have regarding this manual. Authorized dealers can submit feedback using 'Ask Polaris'. Click on 'Ask Polaris', and then click on 'Service Manual / Service Literature Question'.

Consumers, please provide your feedback in writing to: Polaris Industries Inc. ATTN: Service Publications Department, 2100 Hwy 55, Medina, MN 55340.

**Publication Printed August 2013 (PN 9924874 R02)**

## **UNDERSTANDING SAFETY LABELS AND DIRECTIONS**

Throughout this manual, important information is brought to your attention by the following symbols:



SAFETY ALERT WARNING indicates a potential hazard that may result in severe injury or death to the operator, bystander or person(s) inspecting or servicing the vehicle.



SAFETY ALERT CAUTION indicates a potential hazard that may result in minor personal injury or damage to the vehicle.

**CAUTION**

CAUTION indicates special precautions that must be taken to avoid vehicle damage or property damage.

### **NOTE:**

NOTE provides key information by clarifying instructions.

### **IMPORTANT:**

IMPORTANT provides key reminders during disassembly, assembly and inspection of components.

## **TRADEMARKS**

POLARIS ACKNOWLEDGES THE FOLLOWING PRODUCT(S) MENTIONED IN THIS MANUAL:

Loctite, Registered Trademark of the Loctite Corporation

Nyogel, Trademark of Wm. F. Nye Co.

Fluke, Registered Trademark of John Fluke Mfg. Co.

Mity-Vac, Registered Trademark of Neward Enterprises, Inc.

Torx, Registered Trademark of Textron

Hilliard, Trademark of the Hilliard Corporation

Warn, Trademark of Warn Industries

FOX, Registered Trademark of FOX RACING SHOXS

RydeFX, Registered Trademark of ArvinMeritor

Some Polaris factory publications can be downloaded from [www.polarisindustries.com](http://www.polarisindustries.com), purchased from [www.purepolaris.com](http://www.purepolaris.com) or by contacting the nearest Polaris dealer.

<b>GENERAL INFORMATION</b>	<b>1</b>
<b>MAINTENANCE</b>	<b>2</b>
<b>ENGINE</b>	<b>3</b>
<b>ELECTRONIC FUEL INJECTION</b>	<b>4</b>
<b>BODY / STEERING / SUSPENSION</b>	<b>5</b>
<b>CLUTCHING</b>	<b>6</b>
<b>FINAL DRIVE</b>	<b>7</b>
<b>TRANSMISSION</b>	<b>8</b>
<b>BRAKES</b>	<b>9</b>
<b>ELECTRICAL</b>	<b>10</b>



# CHAPTER 1 GENERAL INFORMATION



VEHICLE IDENTIFICATION .....	1.2
MODEL NUMBER DESIGNATION .....	1.2
ENGINE DESIGNATION NUMBER .....	1.2
VEHICLE IDENTIFICATION NUMBER (VIN) DESIGNATION .....	1.2
VEHICLE AND ENGINE SERIAL NUMBER LOCATION .....	1.3
VEHICLE INFORMATION .....	1.3
PUBLICATION NUMBERS .....	1.3
REPLACEMENT KEYS .....	1.4
SPECIAL TOOLS .....	1.5
GENERAL SPECIFICATIONS .....	1.6
MODEL: 2014 RZR XP 1000 / EPS / INT'L .....	1.6
2014 RZR XP 1000 / EPS / INT'L .....	1.7
MODEL: 2014 RZR XP 4 1000 .....	1.8
2014 RZR XP 4 1000 .....	1.9
2014 RZR XP / XP 4 1000 CLUTCH CHARTS .....	1.10
MISC. SPECIFICATIONS AND CHARTS .....	1.11
MASTER TORQUE TABLE .....	1.11
CONVERSION TABLE .....	1.14
STANDARD BOLT TORQUE SPECIFICATION .....	1.15
METRIC BOLT TORQUE SPECIFICATION .....	1.15
SAE TAP / DRILL SIZES .....	1.16
METRIC TAP / DRILL SIZES .....	1.16
DECIMAL EQUIVALENTS .....	1.17

# GENERAL INFORMATION

## VEHICLE IDENTIFICATION

### Model Number Designation

Example: R14ST1EAL

GROUP	MODEL YEAR	CHASSIS	DRIVELINE	ENGINE		CATEGORY	OPTION	REGION
1st digit	2/3rd digit	4th digit*	5th digit*	6th digit*	7th digit*	8th digit	9th digit**	10th digit
Z = RZR	11 12 13 14	J = RZR XP V = RZR X = Multi-pass RZR	E = 4x4 Shaft / IRS H = 4x4 Shaft / IRS T = 4x4 Shaft / Trailing Arm	Displacement in cc divided by 10 and rounded to two digits (i.e. 50 = 498cc) -- OR -- 5 = 550 6 = 570 7 = 760 8 = 850 9 = 875		E = EPS D = Diesel F = D + E	A = ORV E = EU On-road F = INT'L M = Military S = Scandinavian V = EU On-road	C = Calif.
* = digits that would transfer to 17 digit VIN and are used in digits 4-8 respectively ** = 9th digit will be used on color/featured versions of models (not including the base) First 3 digits and 9th digit are used in model number only. They are not used with the 17 digit VIN.								

### Engine Designation Number

**RZRXP 999-14** High Output 4-Stroke DOHC Twin Cylinder, Liquid Cooled, Electric Start

### Vehicle Identification Number (VIN) Designation

Example: 4XAST1EAXE3000000

World Mfg. ID			Vehicle Descriptors					Vehicle Identifiers								
			Chassis	Driveline	Engine Size	Engine Modifier	Category	Check Digit	Model Year *	Mfg. Location	Individual Serial No.					
1	2	3	4	5	6	7	8	9	10	11	12	13	14	15	16	17
4	X	A	S	T	1	E	A	X	E	3	0	0	0	0	0	0
* Model Year: A = 2010; B = 2011; C = 2012; D = 2013; E = 2014																

## Vehicle and Engine Serial Number Location

Whenever corresponding about a Polaris ORV, refer to the vehicle identification number (VIN) and the engine serial number.

The VIN can be found stamped on a portion of the left rear frame, behind the lower shock mounting location. Refer to Figure 1-1.

The engine serial number can be found on a decal applied to the front of the engine crankcase (A) or stamped into the crankcase on the PTO side of the engine (B). Refer to Figure 1-2.

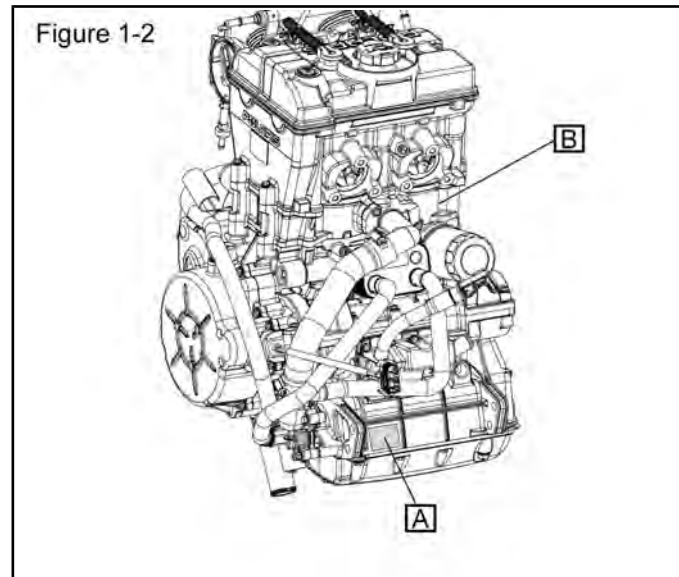
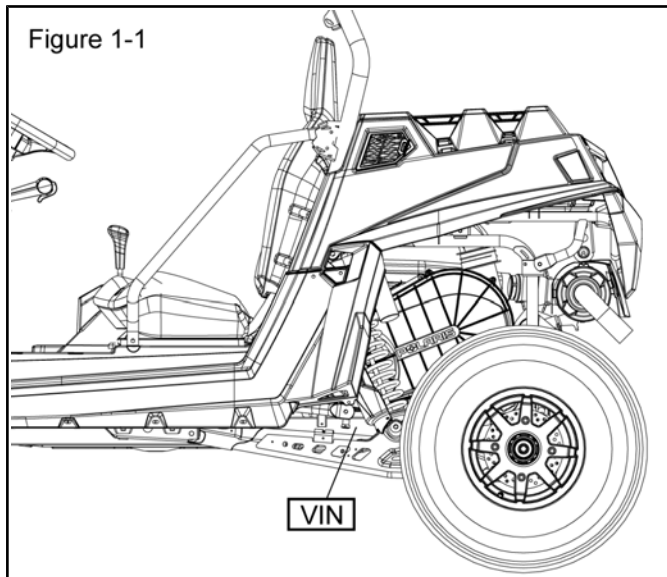

## VEHICLE INFORMATION

### Publication Numbers

MODEL	OWNER'S MANUAL	PARTS MANUAL
2014 RZR XP 1000	9924687	9924688
2014 RZR XP 1000 EPS	9924687	9924688
2014 RZR XP 1000 INT'L	9924687	9924688
2014 RZR XP 4 1000	9924687	9924688

**NOTE:** When ordering service parts be sure to use the correct parts manual.

Polaris factory publications can be found at [www.polaris.com](http://www.polaris.com) or purchased from [www.purepolaris.com](http://www.purepolaris.com).



# GENERAL INFORMATION

---

## Replacement Keys

Replacement keys can be made from the original key. To identify which series the key is, take the first two digits on the original key and refer to the chart to the right for the proper part number.

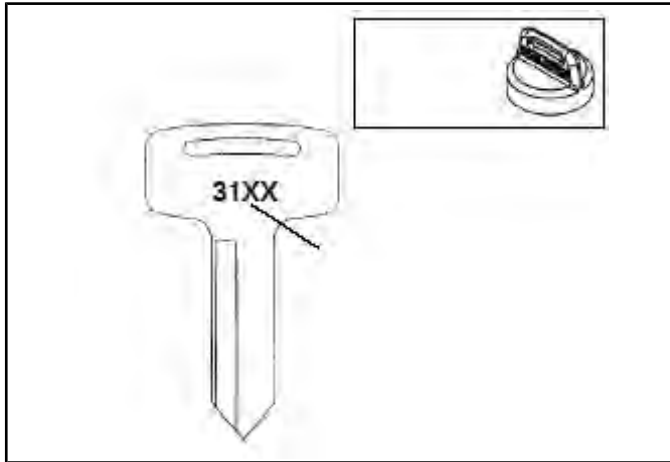

SERIES#	PART NUMBER
20	4010278
21	4010278
22	4010321
23	4010321
27	4010321
28	4010321
31	4110141
32	4110148
67	4010278
68	4010278

## SPECIAL TOOLS

1

Special tools may be required while servicing this vehicle. Some of the tools listed or depicted are mandatory, while other tools may be substituted with a similar tool, if available. Polaris recommends the use of Polaris Special Tools when servicing any Polaris product. Dealers may order special tools through Polaris' official tool supplier, Bosch Automotive Service Solutions, by phone at 1-800-345-2233 or on-line at <http://polaris.service-solutions.com/>

# GENERAL INFORMATION

---

## GENERAL SPECIFICATIONS

MODEL: 2014 RZR XP 1000 / EPS / INT'L

CATEGORY	DIMENSION / CAPACITY
Length	119" / 302.2 cm
Width	64" / 162.5 cm
Height	73.75" / 187.3 cm
Wheel Base	90" / 228.6 cm
Ground Clearance	13.5" / 34.3 cm
Dry Weight	1379 lbs. / 625.5 kg
Gross Vehicle Weight	2168 lbs. / 983 kg
Cargo Box Capacity	300 lbs. / 136 kg
Maximum Weight Capacity (Payload)	740 lbs. / 335.6 kg (Includes riders, cargo and accessories)
Hitch Towing Capacity	This vehicle is not equipped with a hitch for towing loads. Do not use this vehicle for towing. Do not modify the vehicle by adding a hitch.
Hitch Tongue Capacity	



# GENERAL INFORMATION

## 2014 RZR XP 1000 / EPS / INT'L

ENGINE	
Platform	Domestic Twin Cyl., 4-Stroke, DOHC
Engine Displacement	999cc
Number of Cylinders	2
Bore & Stroke	93 x 73.6 mm
Compression Ratio	10.5:1
Engine Idle Speed	1200 +/- 100 RPM
Engine Max Speed	8800 RPM
Valve Clearance (Intake)	0.005-0.007" (0.125-0.175 mm)
Valve Clearance (Exhaust)	0.009-0.011" (0.229-0.275 mm)
Engine Hot Light	Instrument Cluster Indicator
Lubrication	Wet Sump
Oil Requirements	PS4
Oil Capacity	2.5 qts. (2.4 L)
Coolant Capacity	4.9 qt (4.6 L)

FUEL SYSTEM	
Type	Bosch ME17 EFI
Fuel Delivery	Electronic Fuel Pump (in-tank)
Fuel Pressure	58 ± 2 PSI (400 ± 14 kPa)
Fuel Capacity / Requirement	9.5 gal. (36 L) 87 Octane (minimum)

ELECTRICAL	
Alternator Max Output	560 Watts @ 3000 RPM
Lights: Main Headlights	Dual Beam LED cluster
Taillights	0.2 Watt LED cluster
Brake Lights	2.9 Watt LED cluster
Ignition System	ME17 ECU
Spark Plug / Gap	XG4YCX / 0.7-0.8 mm
Battery / Amp Hr	12v Flooded, 575 CCA
DC Outlet	Standard 12 Volt
Relays	Fan, EFI, Fuel Pump, Chassis, EPS (if appl.)
Circuit Breaker	20A Cooling Fan
Fuses	20A EFI 10A Fuel Pump 5A Brake Light 20A Accessory 10A Drive 10A Lights 20A EPS (if appl.)

DRIVETRAIN	
Transmission Type	Polaris Automatic PVT
Shift Type	In Line Shift - P / H / L / N / R
Transmission Gear Ratios:	
High	10.73:1
Low	22.79:1
Reverse	20.41:1
Front Gearcase Lubricant Requirement	Demand Drive 8.5 oz. (250 ml)
Transmission Lubricant Requirement	Full Synthetic AGL 44 oz. (1300 ml)
Drive Belt	3211148

STEERING / SUSPENSION	
Toe Out	1/8 - 3/16" (3.2 - 4.8 mm)
Front Suspension	Independent Dual A-arm Walker Evans™ 2.0"
Front Travel	16" (40.6 cm)
Rear Suspension	Independent Trailing Arm Walker Evans™ 2.5"
Rear Travel	18" (45.7 cm)
Spring Adjustment	Threaded Spanner Wrench Adjustment

WHEELS / BRAKES		
Front Rim / Size	Aluminum 14 x 6	
Rear Rim / Size	Aluminum 14 x 8	
Front Tire Make / Model / Size	Maxxis Bighorn 29 x 9 R14	
Rear Tire Make / Model / Size	Maxxis Bighorn 29 x 11 R14	
Tire Air Pressure	Front	16 psi (110 kPa)
	Rear	16 psi (110 kPa)
Brake System Front & Rear	Foot Actuated 4 Wheel Hydraulic – Dual Bore Caliper	
Brake Fluid	DOT 4	

RZR XP 1000 Clutch Chart, page 1.10

1

# GENERAL INFORMATION

---

## MODEL: 2014 RZR XP 4 1000

CATEGORY	DIMENSION / CAPACITY
Length	146" / 370.8 cm
Width	64" / 162.5 cm
Height	73.75" / 187.3 cm
Wheel Base	117" / 297.2 cm
Ground Clearance	13.5" / 34.3 cm
Dry Weight	1596 lbs. / 724 kg
Gross Vehicle Weight	2560 lbs. / 1161 kg
Cargo Box Capacity	300 lbs. / 136 kg
Maximum Weight Capacity (Payload)	900 lbs. / 408 kg (Includes riders, cargo and accessories)
Hitch Towing Capacity	This vehicle is not equipped with a hitch for towing loads. Do not use this vehicle for towing. Do not modify the vehicle by adding a hitch.
Hitch Tongue Capacity	



# GENERAL INFORMATION

## 2014 RZR XP 4 1000

ENGINE	
Platform	Domestic Twin Cyl., 4-Stroke, DOHC
Engine Displacement	999cc
Number of Cylinders	2
Bore & Stroke	93 x 73.6 mm
Compression Ratio	10.5:1
Engine Idle Speed	1200 +/- 100 RPM
Engine Max Speed	8800 RPM
Valve Clearance (Intake)	0.005-0.007" (0.125-0.175 mm)
Valve Clearance (Exhaust)	0.009-0.011" (0.229-0.275 mm)
Engine Hot Light	Instrument Cluster Indicator
Lubrication	Wet Sump
Oil Requirements	PS4
Oil Capacity	2.5 qts. (2.4 L)
Coolant Capacity	6.0 qt (5.6 L)

FUEL SYSTEM	
Type	Bosch ME17 EFI
Fuel Delivery	Electronic Fuel Pump (in-tank)
Fuel Pressure	58 ± 2 PSI (400 ± 14 kPa)
Fuel Capacity / Requirement	9.5 gal. (36 L) 87 Octane (minimum)

ELECTRICAL	
Alternator Max Output	560 Watts @ 3000 RPM
Lights: Main Headlights	Dual Beam LED cluster
Taillights	0.2 Watt LED cluster
Brake Lights	2.9 Watt LED cluster
Ignition System	ME17 ECU
Spark Plug / Gap	XG4YCX / 0.7-0.8 mm
Battery / Amp Hr	12v Flooded, 575 CCA
DC Outlet	Standard 12 Volt
Relays	Fan, EFI, Fuel Pump, Chassis, EPS (if appl.)
Circuit Breaker	20A Cooling Fan
Fuses	20A EFI 10A Fuel Pump 5A Brake Light 20A Accessory 10A Drive 10A Lights 20A EPS (if appl.)

DRIVETRAIN	
Transmission Type	Polaris Automatic PVT
Shift Type	In Line Shift - P / H / L / N / R
Transmission Gear Ratios:	
High	10.73:1
Low	22.79:1
Reverse	20.41:1
Front Gearcase Lubricant Requirement	Demand Drive 8.5 oz. (250 ml)
Transmission Lubricant Requirement	Full Synthetic AGL 44 oz. (1300 ml)
Drive Belt	3211148

STEERING / SUSPENSION	
Toe Out	1/8 - 3/16" (3.2 - 4.8 mm)
Front Suspension	Independent Dual A-arm Walker Evans™ 2.0"
Front Travel	16" (40.6 cm)
Rear Suspension	Independent Trailing Arm Walker Evans™ 2.5"
Rear Travel	18" (45.7 cm)
Spring Adjustment	Threaded Spanner Wrench Adjustment

WHEELS / BRAKES		
Front Rim / Size	Aluminum 14 x 6	
Rear Rim / Size	Aluminum 14 x 8	
Front Tire Make / Model / Size	Maxxis Bighorn 29 x 9 R14	
Rear Tire Make / Model / Size	Maxxis Bighorn 29 x 11 R14	
Tire Air Pressure	Front	19 psi (131 kPa)
	Rear	20 psi (138 kPa)
Brake System Front & Rear	Foot Actuated 4 Wheel Hydraulic – Dual Bore Caliper	
Brake Fluid	DOT 4	

2014 RZR XP / XP 4 1000 Clutch Charts, page 1.10

1

# GENERAL INFORMATION

---

## 2014 RZR XP / XP 4 1000 CLUTCH CHARTS

### CLUTCH CHART (2014 RZR XP 1000 / EPS / INT'L)

ALTITUDE		SHIFT WEIGHT	DRIVE SPRING	DRIVEN SPRING
Meters (Feet)	0-1500 (0-5000)	26-61 (1323098)	White / Orange (7043924)	Red (3234452)
	1500-3700 (5000 - 12000)	26-55 (1322982)	White / Orange (7043924)	Red (3234452)

### CLUTCH CHART (2014 RZR XP 4 1000)

ALTITUDE		SHIFT WEIGHT	DRIVE SPRING	DRIVEN SPRING
Meters (Feet)	0-1500 (0-5000)	26-67 (1323177)	White / Orange (7043924)	Red (3234452)
	1500-3700 (5000 - 12000)	26-61 (1323098)	White / Orange (7043924)	Red (3234452)

## MISC. SPECIFICATIONS AND CHARTS

### Master Torque Table

ITEM	TORQUE
A-Arm Bolt (front)	42 ft-lb (57 Nm)
Ball Joint Fasteners	42 ft-lbs (57 Nm)
Battery Mount Bracket Fasteners	8 ft-lbs (11 Nm)
Battery Terminal Fasteners	60 in-lbs (7 Nm)
Brake Disc Mounting Bolts	30 ft-lb (41 Nm)
Brake Bleed Screws	48 in-lb (5 Nm)
Brake Caliper Mounting Bolts	40 ft-lbs (54 Nm)
Brake Line Banjo Bolts	15 ft-lbs (20 Nm)
Brake Line Flare Fittings	15 ft-lbs (20 Nm)
Brake Pedal Mount Bracket Bolts	16 ft-lbs (22 Nm)
Brake Switch	15 ft-lbs (20 Nm)
Cab Frame Bolts	40 ft-lb (54 Nm)
Cam Chain Tensioner	29 ft-lb (40 Nm)
Camshaft Carrier Bolts	7 ft-lb (10 Nm)
Camshaft Sprocket Bolts	14 ft-lb (19 Nm)
Clutch Cover (outer) Screws	50 in-lbs (5 Nm)
Connecting Rod Bolts	Step 1: 9 ft-lbs (12 Nm) Step 2: 13 ft-lb (18 Nm) Step 3: Tighten add'n 105°
Coolant Bleed Screw	89 in-lb (10 Nm)
Coolant Temperature Sensor	17 ft-lb (23 Nm)
CPS Retaining Bolt	9 ft-lb (12 Nm)
Crankcase Bolts M10	Step 1: 9 ft-lb (12 Nm) Step 2: 21 ft-lb (28 Nm) Step 3: Tighten add'n 90°
Crankcase Bolts M8	26 ft-lb (35 Nm)
Crankcase Bolts M6	9 ft-lb (12 Nm)
Crankcase Oil Gallery Plug	11 ft-lbs (15 Nm)
Cylinder Head Bolts	Torque in sequence Step 1: 9 ft-lbs (12 Nm) Step 2: 26 ft-lb (35 Nm) Step 3: Additional 180° Step 4: M6 bolts: 7 ft-lb (10 Nm)
Differential Cover Screws (INTL)	22 ft-lb (30 Nm)
Door Fasteners	8 ft-lb (11 Nm)
Drive Clutch Retaining Bolt	96 ft-lb (130 Nm)

ITEM	TORQUE
Drive Clutch Cover Plate Screw	9 ft-lb (12 Nm)
Drive Clutch Shift Weight Fasteners	20 in-lb (2 Nm)
Drive Clutch Spider	290 ft-lb (393 Nm) (Apply 0.4 mL Loctite® 7088 Primer and 0.4 mL Loctite® 620™)
Drive Clutch Spider Jamb Nut	250 ft-lb (339 Nm) (Apply 0.1 mL Loctite® 7088 Primer and 0.1 mL Loctite® 620™)
Driven Clutch Retaining Bolt	55 ft-lb (75 Nm)
Driven Clutch Helix Retaining Screws	48 in-lb (5 Nm)
ECU Mounting Screws	24 in-lb (3 Nm)
Engine Mount (front)	40 ft-lbs (54 Nm)
Engine Oil Plug	12 ft-lbs (16 Nm)
Engine/Transmission Mounting Bolts	Step 1-2: 64 ft-lb (87 Nm) Step 3: 5 ft-lb (7 Nm) Step 4-7: 44 ft-lb (60 Nm) *see procedure for illustration
ETC Mounting Bolts	7 ft-lb (10 Nm)
Exhaust Head Pipe Bolts	18 ft-lb (24 Nm)
Floor Screws	8 ft-lb (11 Nm)
Flywheel Bolt	133 ft-lbs (180 Nm)
Frame Bolts (front to rear)	40 ft-lb (54 Nm)
Front Bumper / Fender Screws	8 ft-lb (11 Nm)
Front Gearcase Cover Plate Screws	11 ft-lbs (15 Nm)
Front Gearcase Drain/Fill Plugs	10 ft-lbs (14 Nm)
Front Gearcase Mounting Bolts	30 ft-lbs (41 Nm)
Fuel Pump PFA Nut	70 ft-lbs (95 Nm)
Fuel Rail Mounting Screws	44 in-lb (5 Nm)
Fuel Tank Block-off Panel	8 ft-lbs (11 Nm)
Fuel Tank Strap Screw	8 ft-lbs (11 Nm)
Hip Bolster Bolts	14 ft-lb (19 Nm)
Hose Clamp	35 in-lb (4 Nm)
Hub Castle Nut (front and rear)	110 ft-lbs (149 Nm)

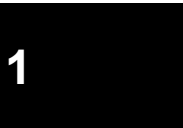



## GENERAL INFORMATION

ITEM	TORQUE
Intake Plenum Mount Screw	22 ft-lb (30 Nm)
Master Cylinder Mount Bolts	23 ft-lbs (31 Nm)
Oil Cooler Bolts	7 ft-lb (10 Nm)
Oil Pump Mounting Bolts	7 ft-lbs (10 Nm)
Oil Pump Pickup Screws	7 ft-lb (10 Nm)
Oil Sump Cover M8 Bolts	26 ft-lb (35 Nm)
Oil Sump Cover M6 Bolts	106 in-lb (12 Nm)
Parking Brake Caliper Assembly Bolts	37 ft-lb (50 Nm)
Parking Brake Disc Mounting Bolts (INTL)	14 ft-lb (20 Nm)
Parking Brake Lever Mounting Bolts	16 ft-lb (22 Nm)
Power Steering Cover Screws	8 ft-lb (11 Nm)
Power Steering Bracket to Frame Nuts	16 ft-lb (22 Nm)
Power Steering Unit to Mount Bracket	30 ft-lb (41 Nm)
Prop Shaft Support Bearing Fasteners	35 ft-lb (47 Nm)
PVT Inner Cover Bolts	12 ft-lb (16 Nm)
PVT Outer Cover Screws	48 in-lb (5 Nm)
Radius Rod Fasteners	40 ft-lb (54 Nm)
Seat Base to Seat Frame Fasteners	8 ft-lbs (11 Nm)
Seat Base to Frame (front)	14 ft-lb (19 Nm)
Seat Base to Frame (rear)	30 ft-lb (41 Nm)
Seat Belt Mounting Fasteners	40 ft-lbs (54 Nm)
Seat Slider Plate Screws	4 ft-lb (5 Nm)
Shift Cable Bracket Bolts	17 ft-lb (23 Nm)
Shock Guard Screws	14 in-lbs (2 Nm)
Shock Mount (front)	44 ft-lb (60 Nm)
Shock Mount (rear)	70 ft-lbs (95 Nm)
Shock Reservoir Mounting Clamps (rear)	35 in-lb (4 Nm)
Skid Plate Fasteners	8 ft-lbs (11 Nm)
Spark Plug	7 ft-lbs (10 Nm)
Speed Sensor Screw	12 ft-lb (16 Nm)
Stabilizer Bar Linkage (rear)	40 ft-lbs (54 Nm)
Stabilizer Bar Mounting Bracket Bolts (rear)	17 ft-lb (23 Nm)

ITEM	TORQUE
Stabilizer Bar Locating Clamp Bolts	10 ft-lb (14 Nm)
Starter Mounting Bolts	7 ft-lb (10 Nm)
Starter One-Way Clutch Screws	9 ft-lb (12 Nm)
Stator Cover Screws	9 ft-lb (12 Nm)
Steering Tilt Shock Fastener	7 ft-lb (10 Nm)
Steering Pivot Tube Fasteners	8 ft-lb (11 Nm)
Steering Rack Mounting Bolts	16 ft-lbs (22 Nm)
Steering Shaft to EPS Unit	15 ft-lbs (20 Nm)
Steering Shaft to Steering Rack	42 ft-lb (57 Nm)
Steering Wheel Nut	65 ft-lbs (88 Nm)
Thermostat Cover Bolts	7 ft-lb (10 Nm)
Throttle Pedal Mounting Fasteners	18 ft-lb (24 Nm)
Tie Rod End to Knuckle	15 ft-lbs (20 Nm) + 90°
Tie Rod Jamb Nuts	14 ft-lbs (19 Nm)
Trailing Arm to Frame	70 ft-lb (95 Nm)
Trailing Arm to Bearing Carrier Fasteners	42 ft-lb (54 Nm)
Transmission Bell Crank Nut	18 ft-lb (24 Nm)
Transmission Case Screws	20 ft-lbs (27 Nm)
Transmission Drain / Fill Plugs	14 ft-lbs (19 Nm)
Transmission Isolator Bolt (rear)	40 ft-lb (54 Nm)
Transmission Rear Mount Bracket Fasteners	17 ft-lb (23 Nm)
Transmission Joint Bracket Bolts	44 ft-lb (60 Nm)
Transmission Park Flange Screws	10 ft-lb (14 Nm)
Transmission Sector Gear Cover	12 ft-lb (16 Nm)
Transmission Shift Fork Screws	10 ft-lb (14 Nm)
Transmission Snorkel Tube Locking Screw	10 ft-lb (14 Nm)
Valve Cover Bolts	7 ft-lbs (10 Nm)
Visor Mounting Screws	8 ft-lb (11 Nm)
Voltage Regulator Fasteners	5 ft-lb (7 Nm)
Water Pump Impeller	7 ft-lb (10 Nm)

## GENERAL INFORMATION

ITEM	TORQUE
	(Apply Loctite® 204™ to bolt threads)
Water Pump Cover Bolts	7 ft-lb (10 Nm) (Apply Loctite® 204™ to bolt threads)
Wheel Lug Nuts	120 ft-lbs (163 Nm)

1

# GENERAL INFORMATION

## Conversion Table

UNIT OF MEASURE	MULTIPLIED BY	CONVERTS TO
ft-lbs	x 12	= in-lbs
in-lbs	x 0.0833	= ft-lbs
ft-lbs	x 1.356	= Nm
in-lbs	x 0.0115	= kg-m
Nm	x 0.7376	= ft-lbs
kg-m	x 7.233	= ft-lbs
kg-m	x 86.796	= in-lbs
kg-m	x 10	= Nm
inch	x 25.4	= mm
mm	x 0.03937	= inch
inch	x 2.54	= cm
mile (mi)	x 1.6	= km
km	x 0.6214	= mile
ounces (oz)	x 28.35	= grams (g)
fluid ounces (fl oz)	x 29.57	= cubic centimeters (cc)
cubic centimeters (cc)	x .03381	= fluid ounces
grams (g)	x 0.035	= ounces
pounds (lb)	x 0.454	= kg
kilogram (kg)	x 2.2046	= lbs
cubic inches (cu in)	x 16.387	= cc
cubic centimeters (cc)	x 0.061	= cubic inches
US quarts	x 0.946	= liters (L)
liters (L)	x 1.057	= US quarts
US gallons	x 3.785	= liters (L)
liters (L)	x 0.264	= US gallons
PSI	x 6.895	= kilopascals (kPa)
kilopascals (kPa)	x 0.145	PSI
$\pi (3.14) \times \text{Radius}^2 \times \text{Height} =$		= cylinder volume
°C to °F:	$9/5 (°C + 32)$	= °F
°F to °C:	$5/9 (°F - 32)$	= °C

# GENERAL INFORMATION

## Standard Bolt Torque Specification

BOLT SIZE	GRADE 2 FT. LBS. (NM)	GRADE 5 FT. LBS. (NM)	GRADE 8 FT. LBS. (NM)
1/4-20	5 (7)	8 (11)	12 (16)
1/4-28	6 (8)	10 (14)	14 (19)
5/16-18	11 (15)	17 (23)	25 (35)
5/16-24	12 (16)	19 (26)	29 (40)
3/8-16	20 (27)	30 (40)	45 (62)
3/8-24	23 (32)	35 (48)	50 (69)
7/16-14	30 (40)	50 (69)	70 (97)
7/16-20	35 (48)	55 (76)	80 (110)
1/2-13	50 (69)	75 (104)	110 (152)
1/2-20	55 (76)	90 (124)	120 (166)

## Metric Bolt Torque Specification

BOLT SIZE	GRADE				
	4.6	4.8	8.8 / 8.9	10.9	12.9
	FT.— LBS. (NM) DRY THREADS				
M3	.3 (.5)	.5 (.7)	1 (1.3)	1.5 (2)	1.5 (2)
M4	.8 (1.1)	1 (1.5)	2 (3)	3 (4.5)	4 (5)
M5	1.5 (2.5)	2 (3)	4.5 (6)	6.5 (9)	7.5 (10)
M6	3 (4)	4 (5.5)	7.5 (10)	11 (15)	13 (18)
M8	7 (9.5)	10 (13)	18 (25)	26 (35)	33 (45)
M10	14 (19)	18 (25)	37 (50)	55 (75)	63 (85)
M12	26 (35)	33 (45)	63 (85)	97 (130)	11 (150)
M14	37 (50)	55 (75)	103 (140)	151 (205)	177 (240)
M16	59 (80)	85 (115)	159 (215)	232 (315)	273 (370)
M18	81 (110)	118 (160)	225 (305)	321 (435)	376 (510)

## GENERAL INFORMATION

### SAE Tap / Drill Sizes

THREAD SIZE	DRILL SIZE	THREAD SIZE	DRILL SIZE
#0-80	3/64	1/2-13	27/64
#1-64	53	1/2-20	29/64
#1-72	53	9/16-12	31/64
#2-56	51	9/16-18	33/64
#2-64	50	5/8-11	17/32
#3-48	5/64	5/8-18	37/64
#3-56	45	3/4-10	21/32
#4-40	43	3/4-16	11/16
#4-48	42	7/8-9	49/64
#5-40	38	7/8-14	13/16
#5-44	37	1-8	7/8
#6-32	36	1-12	59/64
#6-40	33	1 1/8-7	63/64
#8-32	29	1 1/8-12	1 3/64
#8-36	29	1 1/4-7	1 7/64
#10-24	24	1 1/4-12	1 11/64
#10-32	21	1 1/2-6	1 11/32
#12-24	17	1 1/2-12	1 27/64
#12-28	4.6 mm	1 3/4-5	1 9/16
1/4-20	7	1 3/4-12	1 43/64
1/4-28	3	2-4 1/2	1 25/32
5/16-18	F	2-12	1 59/64
5/16-24	I	2 1/4-4 1/2	2 1/32
3/8-16	O	2 1/2-4	2 1/4
3/8-24	Q	2 3/4-4	2 1/2
7/16-14	U	3-4	2 3/4
7/16-20	25/64		

### Metric Tap / Drill Sizes

TAP SIZE	DRILL SIZE	DECIMAL	NEAREST FRACTION
3 x .50	#39	0.0995	3/32
3 x .60	3/32	0.0937	3/32
4 x .70	#30	0.1285	1/8
4 x .75	1/8	0.125	1/8
5 x .80	#19	0.166	11/64
5 x .90	#20	0.161	5/32
6 x 1.00	#9	0.196	13/64
7 x 1.00	16/64	0.234	15/64
8 x 1.00	J	0.277	9/32
8 x 1.25	17/64	0.265	17/64
9 x 1.00	5/16	0.3125	5/16
9 x 1.25	5/16	0.3125	5/16
10 x 1.25	11/32	0.3437	11/32
10 x 1.50	R	0.339	11/32
11 x 1.50	3/8	0.375	3/8
12 x 1.50	13/32	0.406	13/32
12 x 1.75	13/32	0.406	13/32

# GENERAL INFORMATION

## Decimal Equivalents

FRACTION	DECIMAL	MM TO INCHES
1/64	0.0156"	
1/32	0.0312"	1 mm = 0.0394"
3/64	0.0469"	
1/16	0.0625"	
5/64	0.0781"	2 mm = 0.0787"
3/32	0.0938"	
7/64	0.1094"	3 mm = 0.1181"
1/8	0.1250"	
9/64	0.1406"	
5/32	0.1563"	4 mm = 0.1575"
11/64	0.1719"	
3/16	0.1875"	5 mm = 0.1969"
13/64	0.2031"	
7/32	0.2188"	
15/64	0.2344"	6 mm = 0.2362"
1/4	0.25"	
17/64	0.2656"	7 mm = 0.2756"
9/32	0.2813"	
19/64	0.2969"	
5/16	0.3125"	8 mm = 0.3150"
21/64	0.3281"	
11/32	0.3438"	9 mm = 0.3543"
23/64	0.3594"	
3/8	0.375"	
25/64	0.3906"	10 mm = 0.3937"
13/32	0.4063"	
27/64	0.4219"	11 mm = 0.4331"
7/16	0.4375"	
29/64	0.4531"	
15/32	0.4688"	12 mm = 0.4724"
31/64	0.4844"	
1/2	0.500"	13 mm = 0.5118"
33/64	0.5156"	
17/32	0.5313"	
35/64	0.5469"	14 mm = 0.5512"
9/16	0.5625"	
37/64	0.5781"	15 mm = 0.5906"
19/32	0.5938"	
39/64	0.6094"	
5/8	0.625"	16 mm = 0.6299"

FRACTION	DECIMAL	MM TO INCHES
41/64	0.6406"	
21/32	0.6563"	17 mm = 0.6693"
43/64	0.6719"	
11/16	0.6875"	
45/64	0.7031"	18 mm = 0.7087"
23/32	0.7188"	
47/64	0.7344"	19 mm = 0.7480"
3/4	0.750"	
49/64	0.7656"	
25/32	0.7813"	20 mm = 0.7874"
51/64	0.7969"	
13/16	0.8125"	21 mm = 0.8268"
53/64	0.8281"	
27/32	0.8438"	
55/64	0.8594"	22 mm = 0.8661"
7/8	0.875"	
57/64	0.8906"	23 mm = 0.9055"
29/32	0.9063"	
59/64	0.9219"	
15/16	0.9375"	24 mm = 0.9449"
61/64	0.9531"	
31/32	0.9688"	25 mm = 0.9843"
63/64	0.9844"	
1	1.000"	

1



# CHAPTER 2 MAINTENANCE

PERIODIC MAINTENANCE CHART ..... 2.3

- PERIODIC MAINTENANCE OVERVIEW ..... 2.3
- BREAK-IN PERIOD ..... 2.3
- MAINTENANCE CHART KEY ..... 2.3
- PRE-RIDE - 50 HOUR MAINTENANCE INTERVAL ..... 2.4
- 50 - 500 HOUR MAINTENANCE INTERVAL ..... 2.5
- MAINTENANCE QUICK REFERENCE ..... 2.6
- MAINTENANCE QUICK REFERENCE, CONTINUED..... 2.7
- GREASE LUBRICATION POINTS ..... 2.8

LUBRICANTS / SERVICE PRODUCTS..... 2.9

- POLARIS LUBRICANTS, MAINTENANCE AND SERVICE PRODUCTS ..... 2.9

GENERAL VEHICLE INSPECTION AND MAINTENANCE ..... 2.10

- PRE-RIDE / DAILY INSPECTION ..... 2.10
- SHIFT CABLE INSPECTION / ADJUSTMENT ..... 2.10

FUEL SYSTEM AND AIR INTAKE ..... 2.11

- FUEL SYSTEM ..... 2.11
- FUEL TANK VENT LINE ..... 2.11
- FUEL PUMP / FUEL FILTERS ..... 2.11
- FUEL LINES ..... 2.12
- THROTTLE PEDAL INSPECTION ..... 2.12
- ENGINE INTAKE PRE-FILTER SERVICE ..... 2.13
- AIR FILTER SERVICE ..... 2.13
- INTAKE DUCT DRAIN INSPECTION ..... 2.14
- AIR BOX / AIR FILTER ASSEMBLY VIEW ..... 2.15

ENGINE ..... 2.16

- ENGINE OIL LEVEL ..... 2.16
- ENGINE OIL AND FILTER CHANGE ..... 2.17
- ENGINE CRANKCASE BREATHER HOSE INSPECTION ..... 2.18
- ENGINE CYLINDER LEAKDOWN TEST ..... 2.18
- VALVE CLEARANCE INSPECTION ..... 2.19

TRANSMISSION AND FRONT GEARCASE ..... 2.21

- SPECIFICATION CHART ..... 2.21
- TRANSMISSION LUBRICATION ..... 2.21
- FRONT GEARCASE LUBRICATION ..... 2.22

COOLING SYSTEM ..... 2.23

- COOLING SYSTEM OVERVIEW ..... 2.23
- COOLANT STRENGTH ..... 2.23
- COOLANT LEVEL INSPECTION ..... 2.24
- COOLING SYSTEM PRESSURE TEST ..... 2.25
- COOLING SYSTEM HOSES ..... 2.25
- RADIATOR INSPECTION / CLEANING ..... 2.26
- COOLANT DRAIN / FILL ..... 2.26



# MAINTENANCE

---

PVT / FINAL DRIVE / WHEEL AND TIRE.....	2.27
DRIVE CLUTCH / DRIVEN CLUTCH / BELT SERVICE.....	2.27
PVT INTAKE PRE-FILTER SERVICE.....	2.27
PVT DRYING.....	2.27
DRIVE SHAFT BOOT INSPECTION.....	2.28
WHEEL AND HUB TORQUE TABLE.....	2.28
WHEEL REMOVAL.....	2.28
WHEEL INSTALLATION.....	2.28
TIRE INSPECTION.....	2.28
TIRE PRESSURE.....	2.29
ELECTRICAL AND IGNITION SYSTEM.....	2.29
BATTERY MAINTENANCE.....	2.29
BATTERY CHARGING / OFF SEASON STORAGE.....	2.30
BATTERY REMOVAL.....	2.30
BATTERY INSTALLATION.....	2.30
ENGINE / CHASSIS ELECTRICAL GROUND.....	2.31
SPARK PLUG SERVICE.....	2.31
STEERING.....	2.32
STEERING INSPECTION.....	2.32
STEERING WHEEL FREEPLAY.....	2.32
TIE ROD END / WHEEL HUB INSPECTION.....	2.33
WHEEL TOE ALIGNMENT INSPECTION.....	2.33
WHEEL TOE ADJUSTMENT.....	2.34
SUSPENSION (WALKER EVANS™).....	2.35
SPRING ADJUSTMENT.....	2.35
SHOCK COMPRESSION ADJUSTMENT.....	2.36
BRAKE SYSTEM.....	2.37
BRAKE FLUID INSPECTION.....	2.37
BRAKE PAD / DISC INSPECTION.....	2.37
BRAKE HOSE AND FITTING INSPECTION.....	2.37

## PERIODIC MAINTENANCE CHART

### Periodic Maintenance Overview

Inspection, adjustment and lubrication of important components are explained in the periodic maintenance chart.

Inspect, clean, lubricate, adjust and replace parts as necessary. When inspection reveals the need for replacement parts, use genuine Pure Polaris parts available from your Polaris dealer.

2

**NOTE: Service and adjustments are critical. If you're not familiar with safe service and adjustment procedures, have a qualified dealer perform these operations.**

Maintenance intervals in the following chart are based upon average riding conditions and an average vehicle speed of approximately 10 miles per hour. Vehicles subjected to severe use must be inspected and serviced more frequently.

### Severe Use Definition

- Frequent immersion in mud, water or sand
- Racing or race-style high RPM use
- Prolonged low speed, heavy load operation
- Extended idle
- Short trip cold weather operation

Pay special attention to the oil level. A rise in oil level during cold weather can indicate contaminants collecting in the oil sump or crankcase. Change oil immediately if the oil level begins to rise. Monitor the oil level, and if it continues to rise, discontinue use and determine the cause or see your dealer.

### Break-In Period

The break-in period consists of the first 25 hours of operation. Careful treatment of a new engine and drive components will result in more efficient performance and longer life for these components.

- Drive vehicle slowly at first while varying the throttle position. Do not operate at sustained idle.
- Perform regular checks on fluid levels and other areas outlined on the daily pre-ride inspection checklist.
- Change both the engine oil and filter after 25 hours or one month.
- See "Owner's Manual" for additional break-in information.

### Maintenance Chart Key

The following symbols denote potential items to be aware of during maintenance:

■ = **CAUTION: Due to the nature of these adjustments, it is recommended this service be performed by an authorized Polaris dealer.**

► = **SEVERE USE ITEM: See information provided above.**

E = **Emission Control System Service (California).**

**NOTE: Inspection may reveal the need for replacement parts. Always use genuine Polaris parts.**



Improperly performing the procedures marked ■ could result in component failure and lead to serious injury or death. Have an authorized Polaris dealer perform these services.

# MAINTENANCE

## Pre-Ride - 50 Hour Maintenance Interval

ITEM	MAINTENANCE INTERVAL (WHICHEVER COMES FIRST)			REMARKS
	HOURS	CALENDAR	MILES (KM)	
Steering	-	Pre-Ride	-	Inspect or adjust as needed. See Pre-Ride Checklist on Page 2.10.
Front / Rear Suspension	-		-	
Tires	-		-	
Brake Fluid Level	-		-	
Brake Pedal Travel	-		-	
Brake System	-		-	
Wheels / Fasteners	-		-	
Frame Fasteners	-		-	
<b>E</b> Engine Oil Level	-		-	
<b>E</b> Engine Intake Pre-Filter	-	Daily	-	Inspect and clean often
PVT Intake Pre-Filter	-	Daily	-	Inspect and clean often
<b>▶</b> <b>E</b> Intake Baffle Box Drain	-	Daily	-	Inspect drain at the bottom of the air intake baffle box for obstructions
Coolant Level	-	Daily	-	Check level daily
Head Lights / Tail Lights	-	Daily	-	Check operation
<b>▶</b> <b>■</b> Brake Pad Wear / Inspect Parking Brake Pads (INT'L)	10 H	Monthly	100 (160)	Inspect periodically
<b>▶</b> <b>■</b> Parking Brake Cable Adjustment (INT'L)	25 H	-	-	Inspect; adjust tension after first 25 hours
<b>▶</b> <b>E</b> Air Filter	25 H	Monthly	250 (400)	Inspect; replace as needed
Battery	25 H	Monthly	250 (400)	Check terminals; clean; test
<b>▶</b> <b>E</b> Engine Oil & Filter Change (Break-In Period)	25 H	1 M	250 (400)	Perform a break-in oil and filter change at 25 hours or one month; perform every 50 hours or 6 months thereafter
<b>▶</b> Front Gearcase Lubricant (Demand Drive)	25 H	1 M	250 (400)	Initial fluid level inspection; add lubricant if needed
<b>▶</b> Transmission Lubricant (AGL)	25 H	1 M	250 (400)	Initial fluid level inspection; add lubricant if needed
<b>▶</b> General Lubrication	50 H	3 M	500 (800)	Lubricate all fittings, pivots, cables, etc.
<b>■</b> <b>E</b> Throttle Cable / Throttle Pedal	50 H	6 M	500 (800)	Inspect; adjust; replace if necessary
<b>E</b> Throttle Body Intake Boots	50 H	6 M	500 (800)	Inspect ducts for proper sealing / air leaks
Shift Cable / Linkage	50 H	6 M	500 (800)	Inspect; adjust as needed
<b>■</b> Steering	50 H	6 M	500 (800)	Lubricate (if applicable)
<b>▶</b> Front / Rear Suspension	50 H	6 M	500 (800)	Lubricate (if applicable)

▶ Perform these procedures more often for vehicles subjected to severe use.

**E** Emission Control System Service (California)

**■** Have an authorized Polaris dealer perform these services.

## 2.4

## 50 - 500 Hour Maintenance Interval

ITEM	MAINTENANCE INTERVAL (WHICHEVER COMES FIRST)			REMARKS
	HOURS	CALENDAR	MILES (KM)	
■ Cooling System	50 H	6 M	500 (800)	Inspect coolant strength seasonally; pressure test system yearly
▶ Engine Oil/Filter Change	50 H	6 M	1000 (1600)	Perform a break-in oil change at 25 hours or one month
▶ Parking Brake Cable Adjustment (INT'L)	100 H	6 M	1000 (1600)	Inspect; adjust tension as needed
▶ Front Gearcase Lubricant (Demand Drive)	100 H	12 M	1000 (1600)	Change lubricant
▶ Transmission Lubricant (AGL)	100 H	12 M	1000 (1600)	Change lubricant
■ E Fuel System	100 H	12 M	1000 (1600)	Check for leaks at fill cap, fuel line / rail, and fuel pump.
■ E Spark Plug Inspection	100 H	12 M	1000 (1600)	Inspect; replace as needed; torque to specification
▶ Radiator	100 H	12 M	1000 (1600)	Inspect; clean external surfaces
▶ Cooling Hoses	100 H	12 M	1000 (1600)	Inspect for leaks; pressure test system
▶ Engine Mounts	100 H	12 M	1000 (1600)	Inspect, torque to specification
Exhaust Silencer / Pipe	100 H	12 M	1000 (1600)	Inspect
▶ Wiring	100 H	12 M	1000 (1600)	Inspect for wear, routing, security; inspect connectors subjected to water, mud, etc.
■ Clutches (Drive and Driven)	100 H	12 M	1000 (1600)	Inspect; clean; replace worn parts
■ Drive Belt	100 H	12 M	1000 (1600)	Inspect; replace as needed
■ Front Wheel Bearings	100 H	12 M	1000 (1600)	Inspect; replace as needed
▶ Shocks	100 H	-	-	Visually inspect shock seals
■ E Valve Clearance	100 H	-	1000 (1600)	Inspect; adjust as needed
▶ Shocks	-	12 M	1500 (2400)	Change shock oil and inspect seals
▶ Coolant	-	24 M	-	Replace coolant
■ Brake Fluid	200 H	24 M	2000 (3200)	Change every two years (DOT 4)
Spark Arrestor	200 H	24 M	2000 (3200)	Clean out
■ E Valve Clearance	200 H	-	2000 (3200)	Inspect; adjust as needed
■ E Spark Plug Replacement	500 H	36 M	5000 (8000)	Replace; torque to specification
■ Toe Adjustment	-	-	-	Inspect periodically; adjust when parts are replaced
Headlight Aim	-	-	-	Adjust as needed

▶ Perform these procedures more often for vehicles subjected to severe use.

E Emission Control System Service (California)

■ Have an authorized Polaris dealer perform these services.

# MAINTENANCE

## Maintenance Quick Reference

ITEM	LUBE REC.	METHOD	FREQUENCY*
<b>Oil Fill Cap (Item 1):</b> - Under Cargo Box Access Panel <b>Oil Filter (Item 2) / Dipstick (Item 3):</b> - Behind Engine Access Panel	Polaris PS-4 or Polaris PS-4 Extreme Duty	Add oil to proper level on dipstick	Perform a break-in oil and filter change at 25 hrs or one month; perform every 50 hrs thereafter
<b>Engine Coolant</b> - Under Front Hood / Access Panel	Polaris 60/40 Coolant	Maintain coolant level in coolant reservoir bottle (Item 4).	Check level daily; change coolant every two years

\* More often under severe use, such as operation in water or under severe loads.

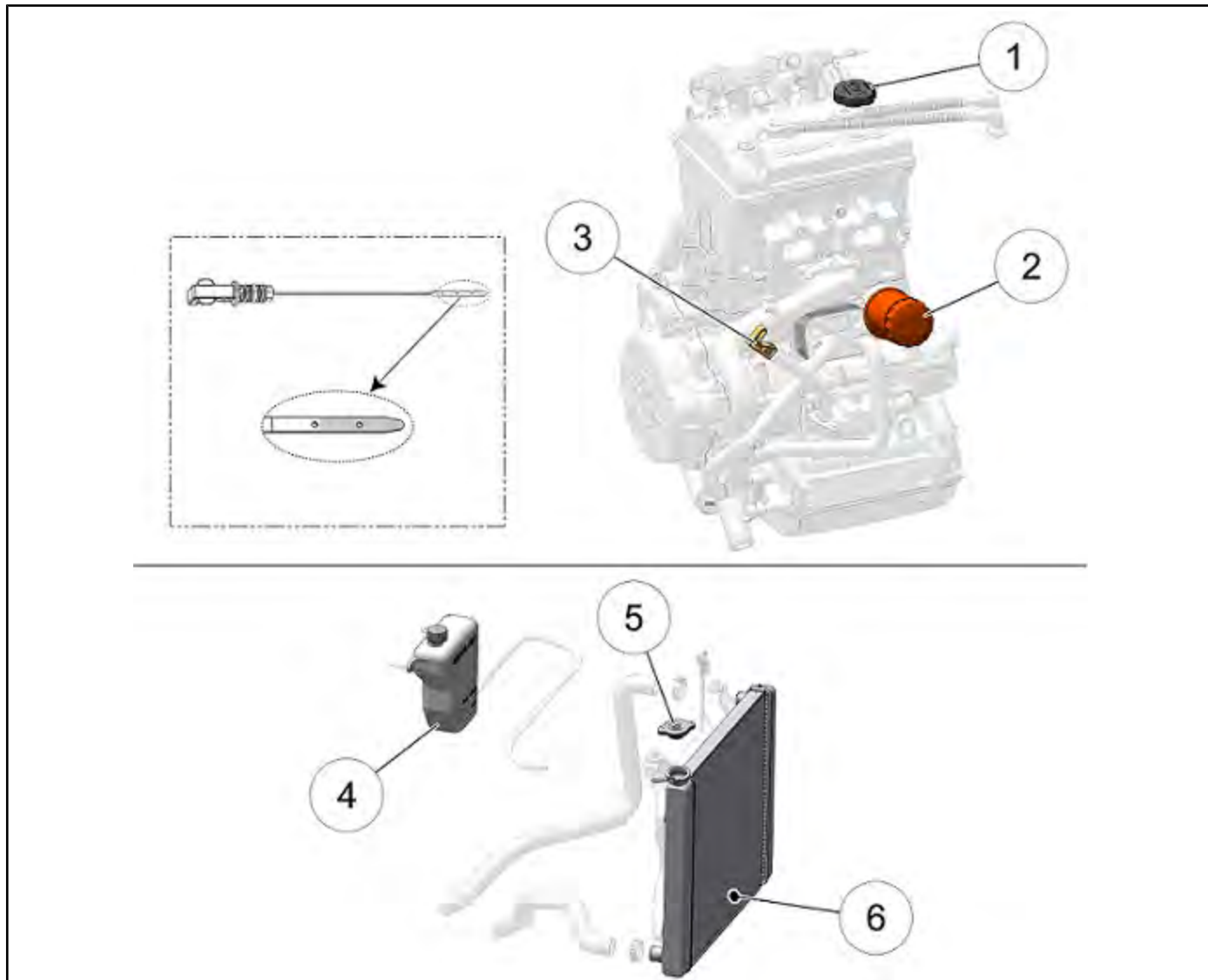

## Maintenance Quick Reference, Continued...

ITEM	LUBE REC.	METHOD	FREQUENCY*
Brake Fluid	Polaris DOT 4 Brake Fluid	Maintain fluid level between "MAX" and "MIN" lines on the master cylinder reservoir (Item 1)	Check level during pre-ride inspection; change fluid every two years
Front Gearcase	Polaris Demand Drive	Add lubricant until it is visible at the fill hole threads (Item 2) (□ 8.5 oz. (250 ml))	Initial level check at 25 hours or 1 month; Change lubricant at 100 hours or every 12 months, whichever comes first
Transmission	Polaris AGL	Add lubricant until it is visible at the fill hole threads (Item 3)	

2

\* More often under severe use, such as operation in water or under severe loads.

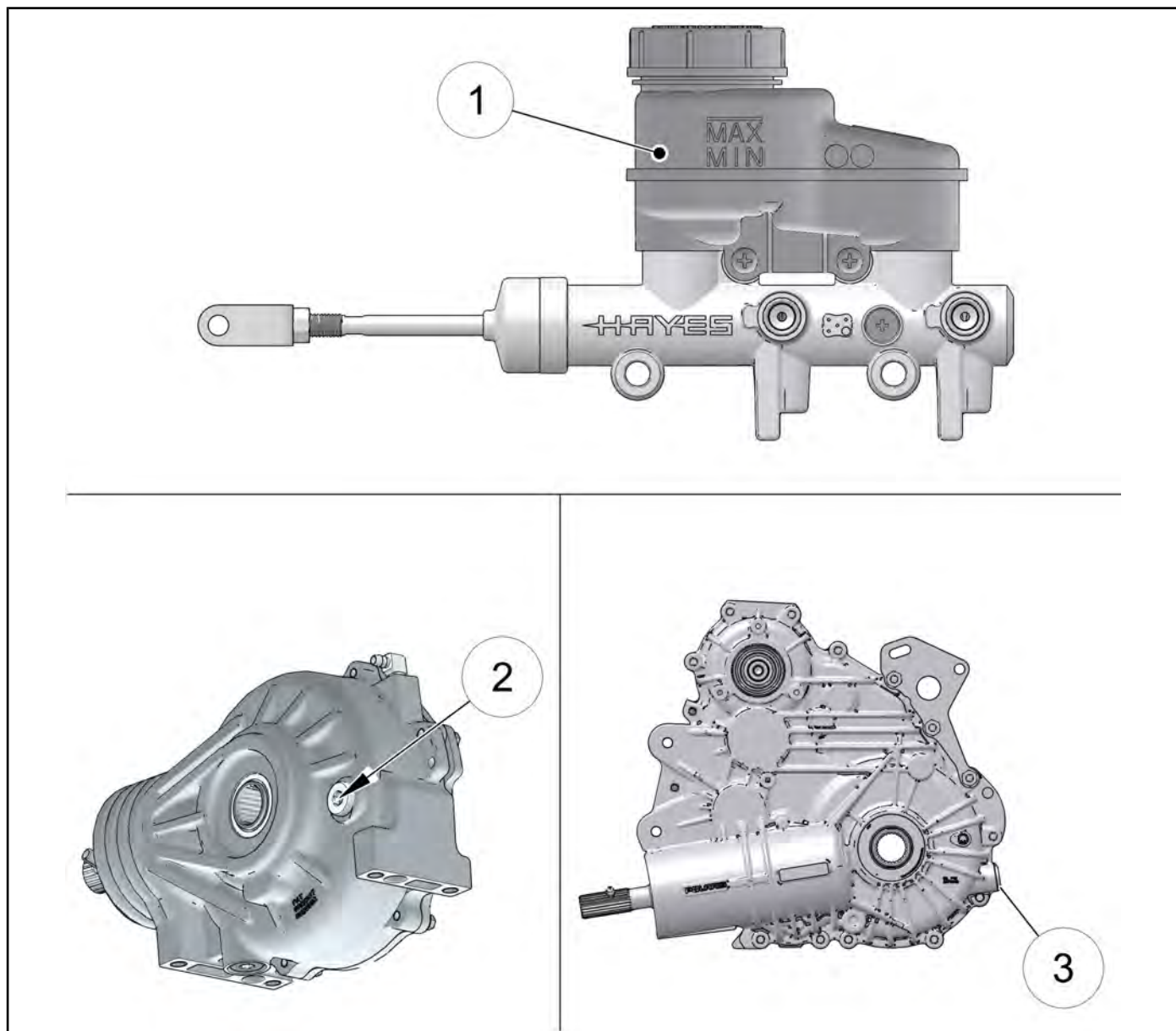

# MAINTENANCE

## Grease Lubrication Points

There are grease fittings at each front A-arm pivot point, each rear torsion bar bushing and on the front propshaft yokes. Apply grease until all traces of water have been purged out at each of these areas.

ITEM	METHOD	RECOMMENDED LUBE	FREQUENCY
Front A-arm Pivot Bushings	Grease 3 fittings on each side of the vehicle (Item 1)	Polaris All Season Grease	Grease fittings every 500 miles (800 km); Grease before long periods of storage, and after thoroughly washing or submerging the vehicle
Propshaft Yokes	Grease middle and rear fittings (Item 2)	Polaris Premium U-Joint Grease	
Front Stabilizer Bar Bushings (INT'L)	Grease the fitting on each side of the vehicle (Item 3)	Polaris All Season Grease	
Rear Torsion Bar Bushings	Grease 2 fittings through the skid plate access holes on each side of the vehicle (Item 4)	Polaris All Season Grease	

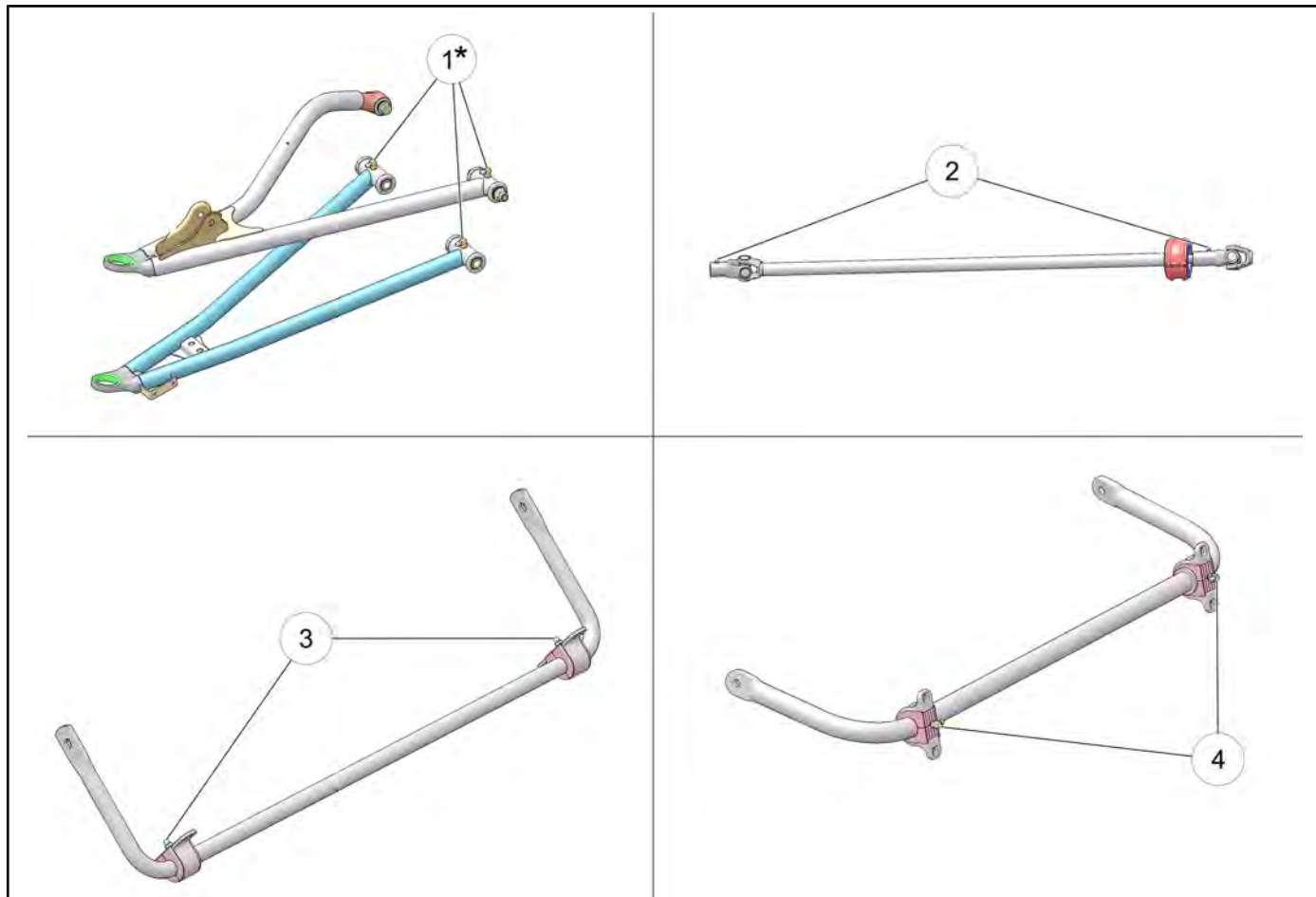

\*There is no grease point on the upper control arm rear mount.

**LUBRICANTS / SERVICE PRODUCTS**

**Polaris Lubricants, Maintenance and Service Products**

PART NO.	DESCRIPTION
<b>Engine Lubricant</b>	
2870791	Fogging Oil (12 oz. Aerosol)
2876244	PS-4 Synthetic 4-Cycle Engine Oil (Quart)
2876245	PS-4 Synthetic 4-Cycle Engine Oil (Gallon)
2878920	PS-4 Extreme Duty Synthetic 4-Cycle Engine Oil (Quart)
2878919	PS-4 Extreme Duty Synthetic 4-Cycle Engine Oil (Gallon)
2540086	Engine Oil Filter
2879723	Engine Oil Change Kit (PS-4)
2879324	Engine Oil Change Kit (PS-4 Extreme Duty)
<b>Gearcase / Transmission Lubricants</b>	
2878068	AGL (1 Qt.) (12 Count)
2878069	AGL (1 Gal.) (4 Count)
2878070	AGL Gearcase Lubricant (2.5 Gal.) (2 Count)
2877922	Demand Drive (Quart)
2877923	Demand Drive (2.5 Gallon)
2870465	Oil Pump for 1 Gallon Jug
<b>Grease / Specialized Lubricants</b>	
2871312	Grease Gun Kit
2871322	Premium All Season Grease (3 oz. cartridge) (24 Count)
2871423	Premium All Season Grease (14 oz. cartridge) (10 Count)
2871460	Starter Drive Grease (12 Count)
2871515	Premium U-Joint Lube (3 oz.) (24 Count)
2871551	Premium U-Joint Lube (14 oz.) (10 Count)
2871329	Dielectric Grease (Nyogel™)
<b>Coolant</b>	
2871323	60/40 Coolant (Gallon) (6 Count)
2871534	60/40 Coolant (Quart) (12 Count)

**NOTE: Each item can be purchased separately at your local Polaris dealer.**

PART NO.	DESCRIPTION
<b>Additives / Sealants / Thread Locking Agents / Misc.</b>	
2871950	Loctite® Threadlock 242 (6 ml.) (12 count)
2871326	Premium Carbon Clean (12 oz.) (12 count)
2870652	Fuel Stabilizer (16 oz.) (12 count)
2872189	DOT 4 Brake Fluid (12 count)
2871557	Crankcase Sealant, 3-Bond 1215 (5 oz.)

**NOTE: The number count indicated by each part number in the table above indicates the number of units that are shipped with each order.**





# MAINTENANCE

## GENERAL VEHICLE INSPECTION AND MAINTENANCE

### Pre-Ride / Daily Inspection

Perform the following pre-ride inspection daily, and when servicing the vehicle at each scheduled maintenance.

- Engine Oil - Check for proper level on dipstick (refer to "Engine Oil Level" procedure)
- Tires - check condition and pressures
- Fuel tank - fill to proper level
- All brakes - check operation and fluid level and adjustment (includes parking brake on INT'L Model)
- Headlights/Taillights/Brakelights - also check operation of all indicator lights, instrument cluster and switches
- Ignition switch - check for proper function
- Wheels - check for tightness of wheel nuts and axle nuts; check to be sure axle nuts are secured by cotter pins
- Engine Intake Pre-Filter - Inspect pre-filter and clean with soapy water and low pressure compressed air if necessary
- PVT Intake Pre-Filter - Inspect pre-filter and clean with soapy water and low pressure compressed air if necessary
- Steering - check for free operation noting any unusual looseness in any area
- Loose parts - visually inspect vehicle for any damaged or loose nuts, bolts or fasteners
- Engine coolant - check for proper level at the recovery bottle
- Drive Shaft Boots - Inspect inner and outer boots for tears or damage on both front and rear drive shafts
- Check all front and rear suspension components for wear or damage.

### Shift Cable Inspection / Adjustment

Shift cable adjustment may be necessary if symptoms include:

- No gear position or AWD display on instrument cluster
  - Ratcheting noise on deceleration
  - Inability to engage into a gear
  - Excessive gear lash (noise)
  - Gear selector moving out of desired range
1. Locate the shift cable (Item 1) attached to the transmission case in the right rear wheel well area.
  2. Inspect shift cable, clevis pin, pivot bushings (Item 4), and dust boot (Item 3). Replace if worn or damaged.

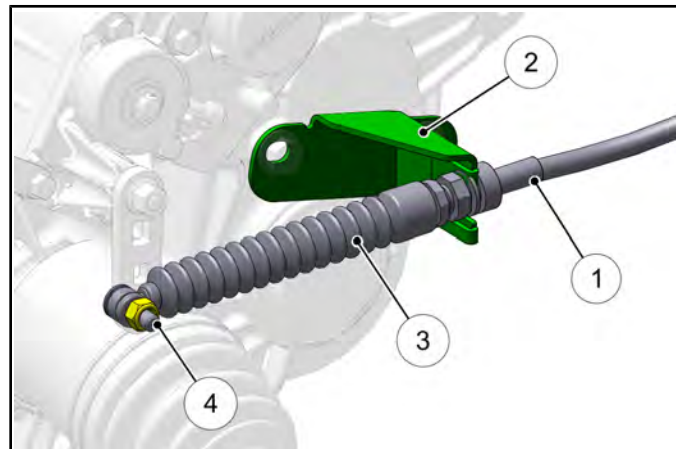

3. If adjustment is required, loosen the lower jam nut (Item 6) and pull the cable out of the mount (Item 2) to move the upper jam nut (Item 5).

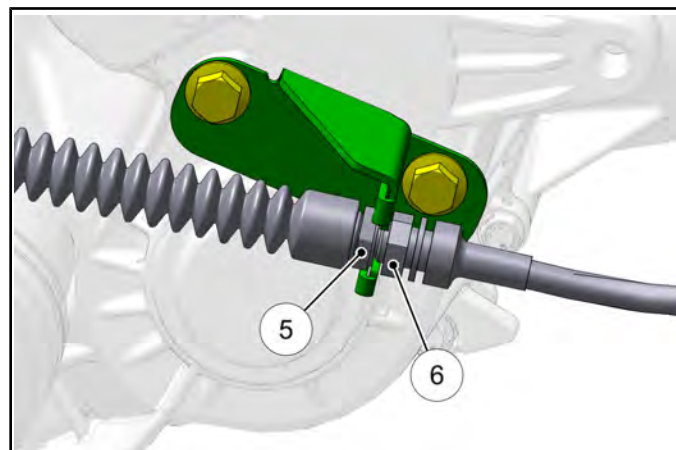

4. Adjust the shift cable so there is the same amount of cable travel when shifting slightly past HIGH gear and PARK.

5. Thread the upper or lower jam nut as required to obtain proper cable adjustment.

**NOTE:** This procedure may require a few attempts to obtain the proper adjustment.

6. Once the proper adjustment is obtained, place the shift cable and upper jam nut into the mount. Tighten the lower jam nut against the mount.
7. Start engine and shift through all gears to ensure the shift cable is properly adjusted. If transmission still ratchets after cable adjustment, the transmission will require service.

## FUEL SYSTEM AND AIR INTAKE

### Fuel System



Gasoline is extremely flammable and explosive under certain conditions.

Always stop the engine and refuel outdoors or in a well ventilated area.

Do not smoke or allow open flames or sparks in or near the area where refueling is performed or where gasoline is stored.

Do not overfill the tank. Do not fill the tank neck.

If you get gasoline in your eyes or if you swallow gasoline, seek medical attention immediately.

If you spill gasoline on your skin or clothing, immediately wash it off with soap and water and change clothing.

Never start the engine or let it run in an enclosed area. Engine exhaust fumes are poisonous and can result in loss of consciousness or death in a short time.

Never drain the fuel when the engine is hot. Severe burns may result.

**2**

### Fuel Tank Vent Line

Symptoms of a restricted fuel tank vent include the following: collapsing fuel tank, engine miss or hesitation, loss of engine performance or high exhaust temperatures.

1. Remove the seats and the engine service panel.
2. Check the fuel tank vent line for signs of wear, deterioration or damage. Replace vent line if necessary.
3. Be sure the vent line is routed properly and secured with cable tie(s).

**NOTE:** Make sure vent line is not kinked or pinched.

### Fuel Pump / Fuel Filters

The fuel pump assembly (Item 1) is located in the fuel tank under the passenger seat.

The RZR XP 1000 EFI engine uses a serviceable, high-volume, high-pressure, fuel pump that includes a preliminary filter (Item 2) and an internal fine filter (Item 3) located before the pump regulator.

**2.11**

## MAINTENANCE

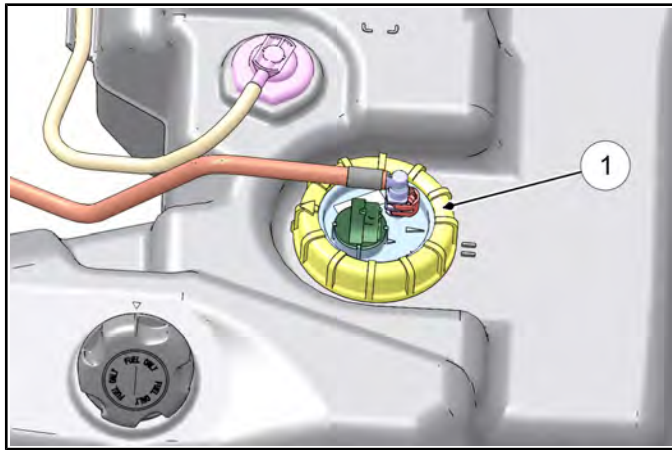

**NOTE:** Neither filter is serviceable individually. Must replace the fuel pump as an assembly.

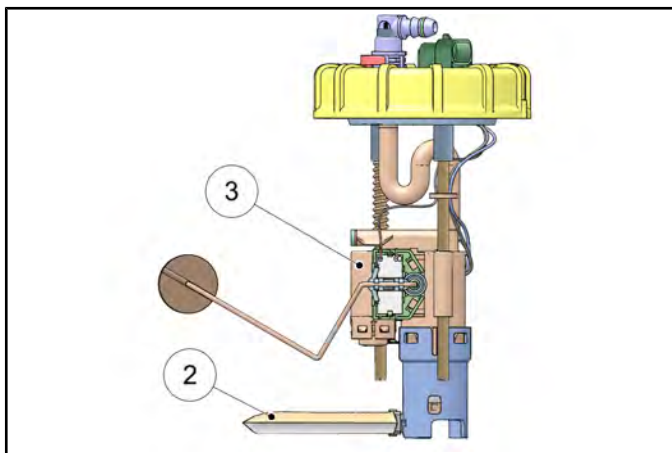

Refer to Chapter 4 for fuel pump replacement and all other information related to the EFI System.

### Fuel Lines

1. Check the quick-connect fuel line (Item 1) at the fuel tank for signs of wear, deterioration, damage or leakage. Replace line(s) if necessary.

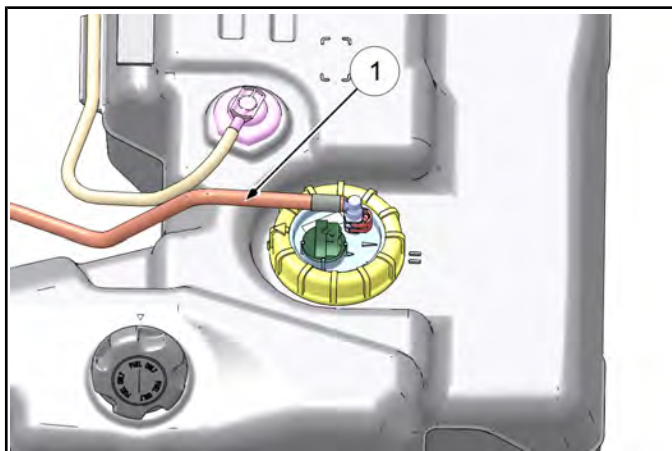

2. Locate the fuel supply fitting (Item 2) through the right rear wheel well on the upper right side of the engine. Check the line and quick-connect fitting for signs of wear, deterioration, damage or leakage. Replace line if necessary.

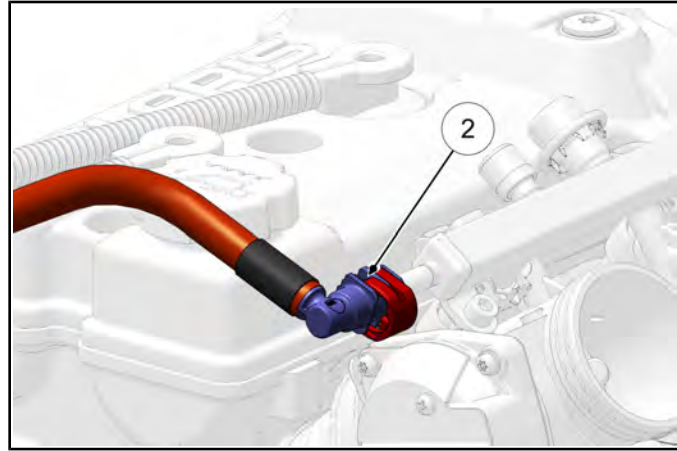

3. Be sure fuel lines are routed and retained properly.

**NOTE:** Make sure lines are not kinked or pinched.

### Throttle Pedal Inspection

This vehicle is equipped with Pedal Position Sensor (Item 1) used to detect when the throttle pedal (Item 2) is pushed or released.

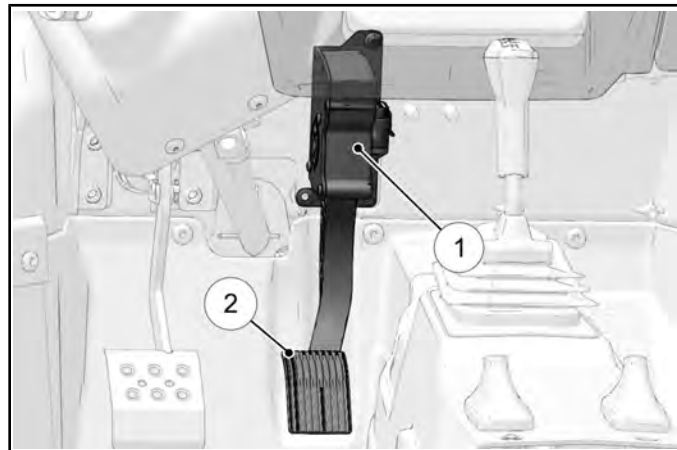

The throttle pedal should move freely and always return back to its idle position when released.

Check throttle pedal periodically.

## Engine Intake Pre-Filter Service

It is recommended that the engine intake pre-filter be inspected daily. The filter should be inspected using the following procedure:

1. The engine intake pre-filter is located just above the right rear wheel fender.
2. Loosen the knob on top of the assembly and lift up to disengage the tab from the cargo box.

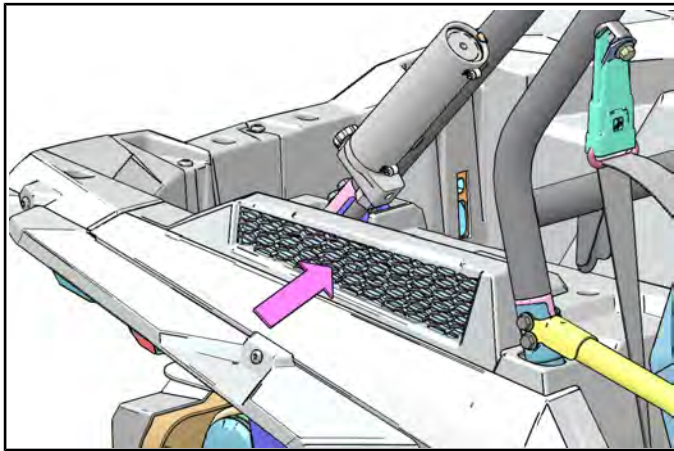

3. Inspect the pre-filter. If necessary, clean with soapy water and dry with low pressure compressed air.

## Air Filter Service

Inspect the air filter at the intervals outlined in the Periodic Maintenance Chart. In extremely dusty conditions, air filter replacement will be required more often.

1. Remove the cargo box access panel (Item 1).

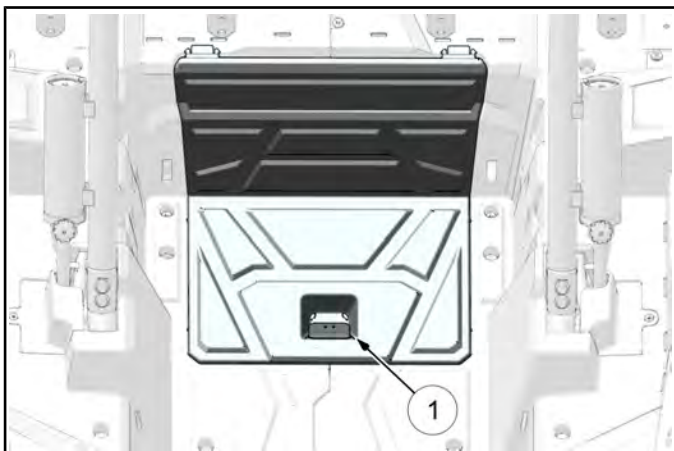

2. Disengage the four cover latches (Item 2).

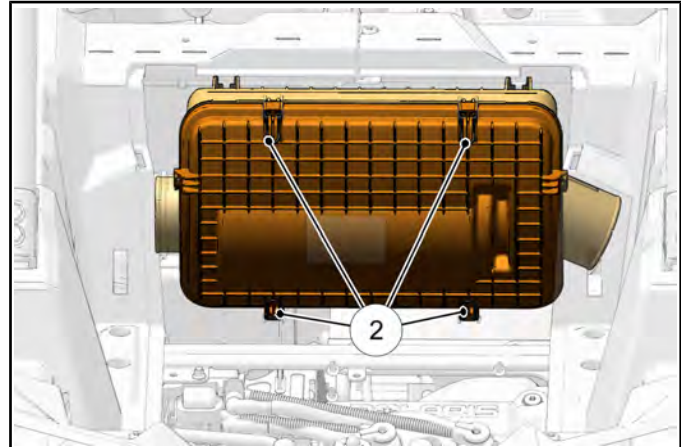

3. Pull cover rearward far enough to remove air filter (Item 3).

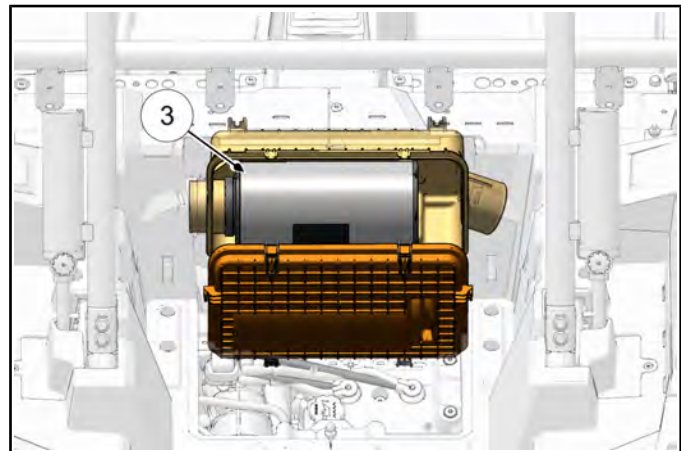

4. Inspect the air box for oil or water deposits. Wipe away any deposits with a clean shop towel.

**NOTE: If the filter has been soaked with fuel or oil it must be replaced.**

5. Inspect the air filter and replace if necessary.

**NOTE: DO NOT attempt to clean the air filter.**

6. Place the air filter into the air box and reinstall the air box cover.

**NOTE: Be sure the lower tabs on the air box cover are properly engaged into the airbox.**

7. Engage the cover latches.

8. Reinstall the cargo box access panel.

# MAINTENANCE

---

## Intake Duct Drain Inspection

It is recommended that the intake drain be inspected daily.

1. Access the intake baffle box drain (Item 1) through the left rear wheel well.

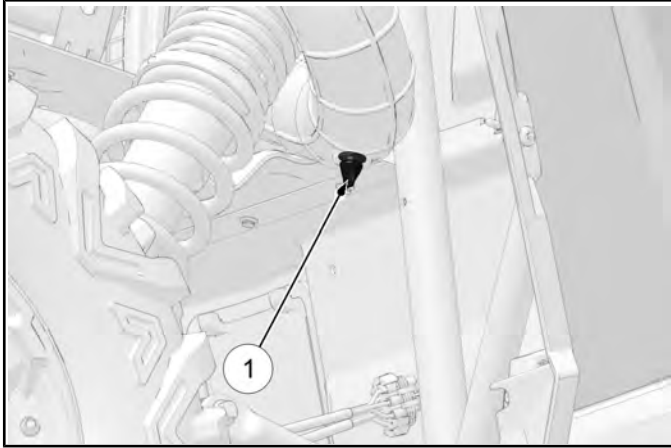

2. Check the drain to ensure it is not plugged with debris so it can drain properly. If needed, remove the drain from the baffle box during inspection.

**Air Box / Air Filter Assembly View**

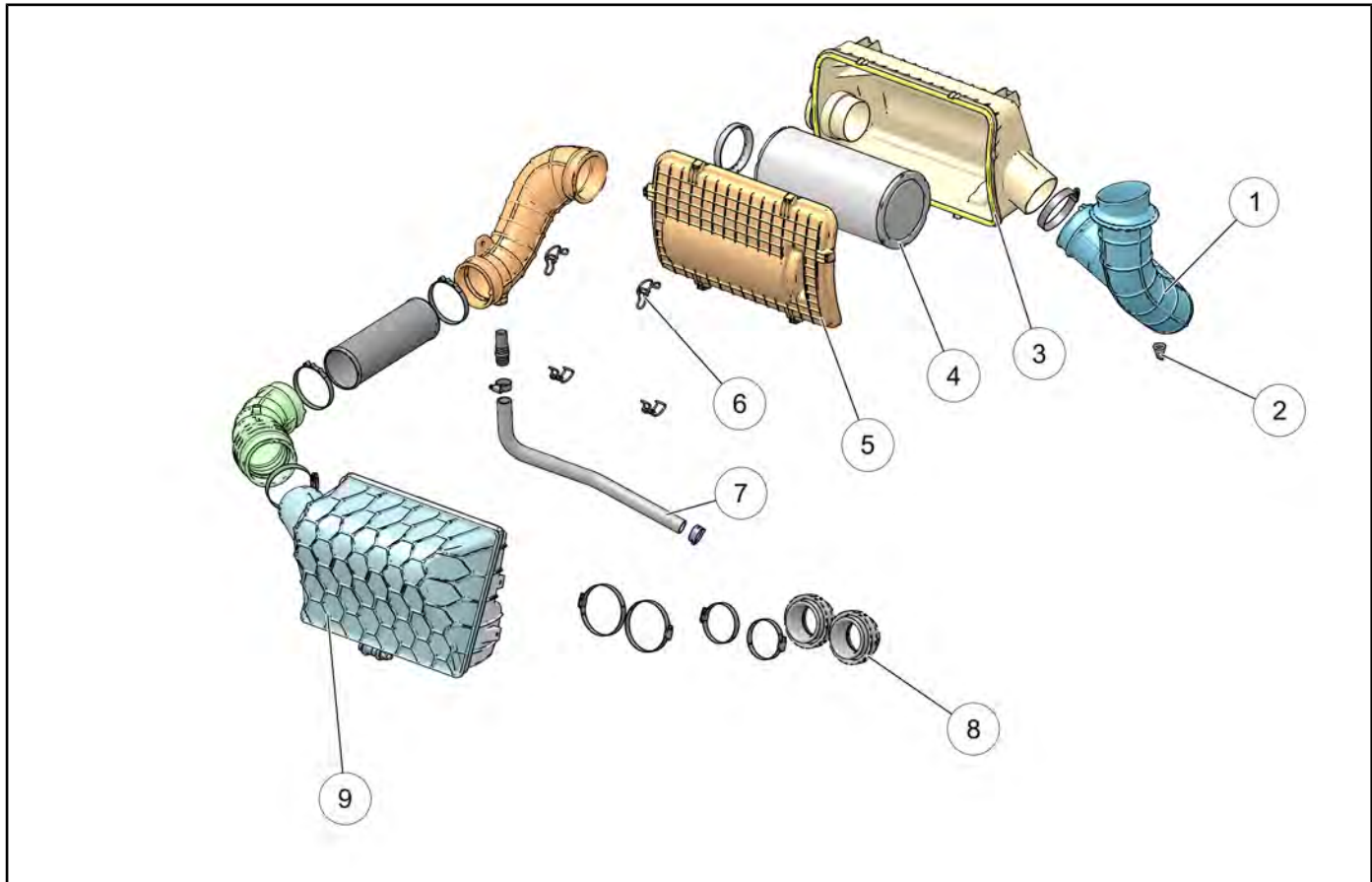

**2**

1. Intake Airbox Hose	6. Airbox Clip (4)
2. Drain Cap	7. Vent Hose
3. Airbox	8. Intake Tubes
4. Air Filter	9. Engine Intake Housing
5. Airbox Cover	

# MAINTENANCE

## ENGINE

### Engine Oil Level

The 2014 RZR XP 1000 engine has a wet-sump design, meaning the engine oil is contained in the bottom of the crankcase. To check the oil level, follow the procedure listed below:

Access the oil dipstick through the opening in front of the passenger rear tire.

Access the oil fill cap through the cargo box access panel.

Polaris recommends the use of PS-4 Synthetic or PS-4 Extreme Duty Synthetic 4-Cycle Engine Oil.

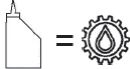
<b>Recommended Engine Oil:</b>
<b>PS-4 (PN 2876244)</b> <i>Ambient Temp Range: -35° F to 100° F</i>
<b>PS-4 Extreme Duty (PN 2878920)</b> <i>Ambient Temp Range: 0° F to 120° F</i>
<b>Capacity: 2.5 Quarts (2.4 L)</b>

1. Position vehicle on a level surface and place the transmission in PARK.
2. Stop the engine and allow it to cool down before removing the dipstick.
3. Unlock the dipstick lever (Item 1). Remove the dipstick and wipe it dry with a clean cloth.

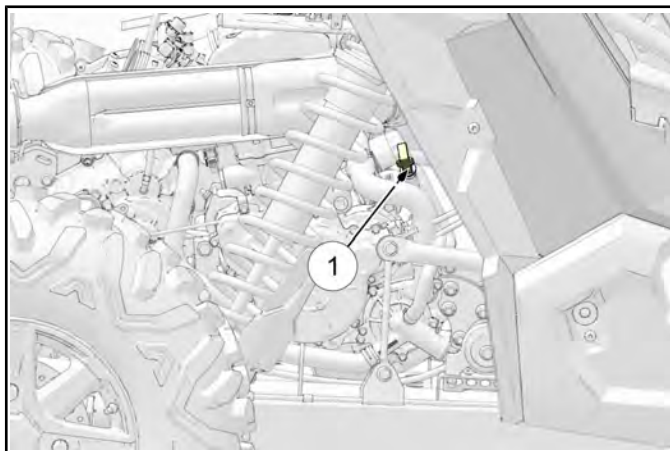

4. Reinstall the dipstick and push it into place. Do not lock the dipstick

**NOTE: Make certain the dipstick is inserted all the way into the dipstick tube to keep the depth of the dipstick consistent.**

5. Remove the dipstick and check the oil level.
6. Add the recommended oil as necessary to bring the oil level within the SAFE range on dipstick. Do not overfill (see NOTE below).

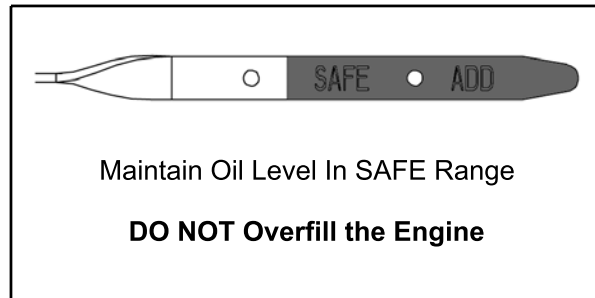

**NOTE: A rising oil level between checks during cold weather operation can indicate contaminants such as gas or moisture collecting in the crankcase. If the oil level is over the upper mark, change the oil immediately.**

7. Add engine oil through the oil fill cap (Item 2) located on top of the valve cover, under the cargo box access panel.

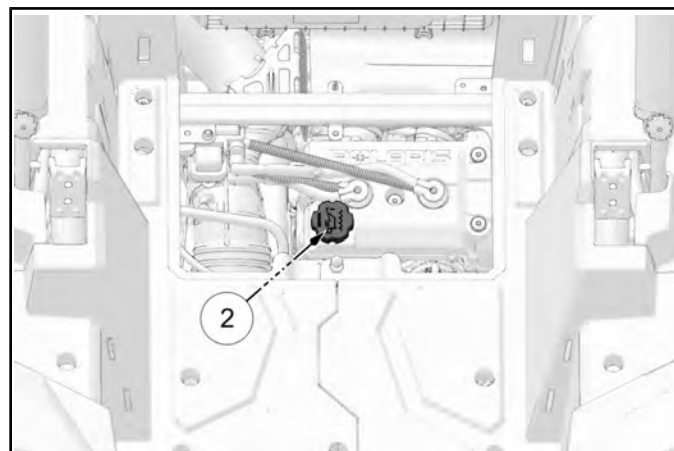

8. When finished, reinstall dipstick and lock the lever.

## Engine Oil and Filter Change

Always change engine oil and filter at the intervals outlined in the Periodic Maintenance Chart. Always change the oil filter whenever changing the engine oil.

The engine oil dipstick is located on the front side of the engine. Access the dipstick through the engine service panel.

The engine oil fill cap is located on top of the valve cover. Access the oil fill cap through the cargo box access panel.

The crankcase drain plug is located on the bottom of the crankcase. Access the drain plug through the skid plate access hole located directly under the crankcase.

1. Position vehicle on a level surface and place the transmission in PARK.
2. Stop the engine and allow it to cool down.
3. Clean the area around the crankcase drain plug.

### CAUTION

Use caution when performing this procedure. Do not allow hot engine oil to come into contact with skin, as serious burns may result.

4. Place a drain pan under the engine crankcase and remove the drain plug (Item 1). Allow the oil to drain completely.

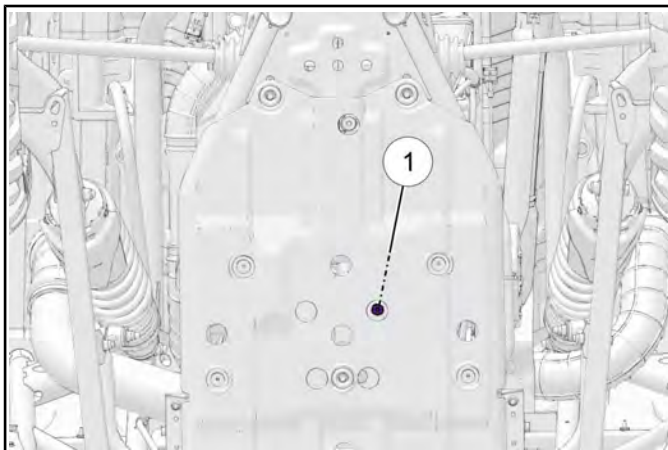

5. Remove the seats and engine service panel to access the oil filter.

6. Using the Oil Filter Wrench (PU-50105), turn the oil filter (Item 2) counter-clockwise to remove it.

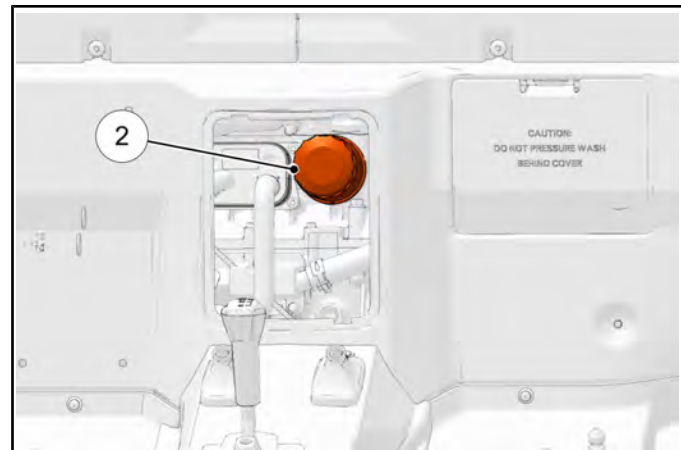

**Oil Filter Wrench:**  
PU-50105: 2.5" (64 mm)

7. Using a clean dry cloth, clean the filter sealing surface on the engine crankcase.
8. Lubricate the O-ring on the new oil filter with a film of fresh engine oil. Check to make sure the O-ring is in good condition. Install it by hand until the O-ring contacts the sealing surface, then turn an additional 1/2 turn.



**Oil Filter Torque:**  
Turn by hand until filter O-ring contacts sealing surface, then turn an additional 1/2 turn.

9. Replace the sealing washer on drain plug.

**NOTE: The sealing surface on the drain plug should be clean and free of burrs, nicks or scratches.**

10. Reinstall the engine crankcase drain plug. Torque drain plug to specification.



**Engine Oil Drain Plug:**  
12 ft-lbs (16 Nm)



# MAINTENANCE

11. Remove oil fill cap (see “Engine Oil Level”). Fill engine with 2.5 quarts (2.4 L) of recommended engine oil.

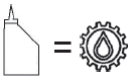
<b>Recommended Engine Oil:</b> <b>PS-4 (PN 2876244)</b> <i>Ambient Temp Range: -35° F to 100° F</i>
<b>PS-4 Extreme Duty (PN 2878920)</b> <i>Ambient Temp Range: 0° F to 120° F</i>
<b>Capacity: 2.5 Quarts (2.4 L)</b>

12. Verify the transmission is still in PARK.
  13. Start the engine and allow it to idle for 30 seconds.
  14. Stop the engine and inspect for oil leaks. Wait at least 15 seconds before removing the dipstick.
  15. Unlock the dipstick lever. Remove the dipstick and wipe it dry with a clean cloth (see “Engine Oil Level”).
  16. Reinstall the dipstick and push it into place. Do not lock the dipstick
- NOTE: Make certain the dipstick is inserted all the way into the dipstick tube to keep the depth of the dipstick consistent.**
17. Remove the dipstick and check the oil level.
  18. Add the recommended oil as necessary to bring the oil level within the SAFE range on dipstick. Do not overfill.



Maintain Oil Level In SAFE Range
<b>DO NOT Overfill the Engine</b>

19. When finished, reinstall the oil fill cap, oil dipstick and lock the lever.
20. Reinstall the cargo box access panel, engine service panel and seats.
21. Dispose of used oil and filter properly.

## Engine Crankcase Breather Hose Inspection

The engine crankcase is equipped with a breather hose. Inspect the breather hose for possible kinks or wear. The hose is form fitted for proper fit.

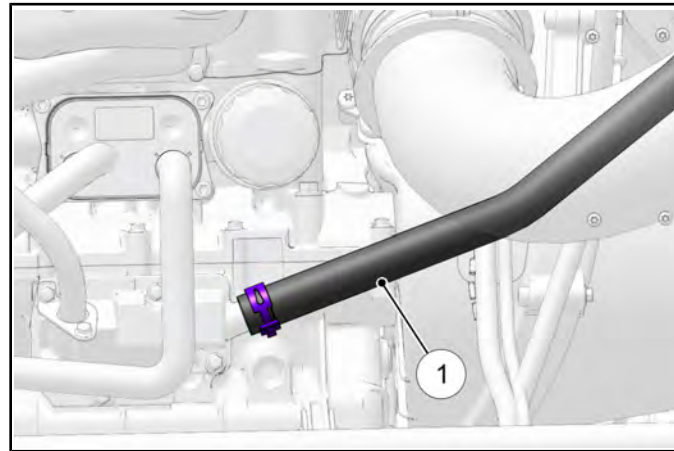
Follow the breather hose (Item 1) from the crankcase to the engine intake duct.



**NOTE: Make sure hoses are not kinked or pinched.**

## Engine Cylinder Leakdown Test

A cylinder leak-down test is the best indication of engine condition. Follow tester manufacturer's instructions to perform a cylinder leak-down test. Never use high pressure leakage testers as crankshaft seals may dislodge and leak.

<b>Cylinder Leakage Service Limit: 20%</b>
<b>If leakage exceeds service limit, inspect the engine for the cause.</b>

## Valve Clearance Inspection

**NOTE:** Valve clearance inspection should be performed on a cold engine, at room temperature.

1. Remove the driver's seat. Disconnect the negative (-) battery cable.
2. Remove the engine access panel.
3. Remove eight screws retaining the outer clutch cover.
4. Maneuver the outer clutch cover to allow access to the drive clutch, in order to rotate the engine.

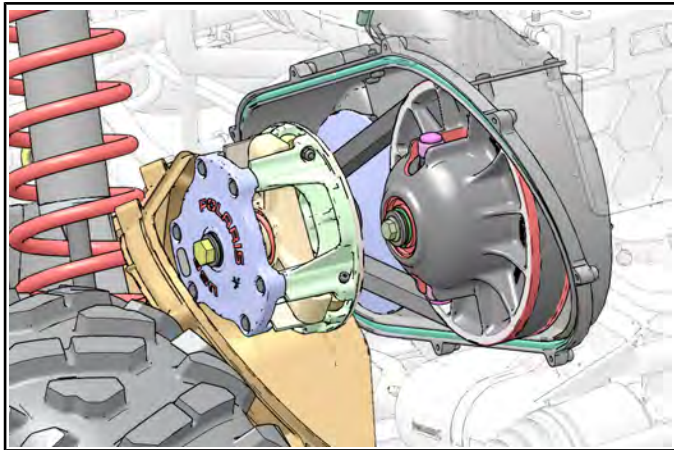

**NOTE:** Removal of left rear wheel or left rear shock is **NOT** necessary to perform this procedure.

5. Remove the spark plug wires to gain access to valve cover as shown below.

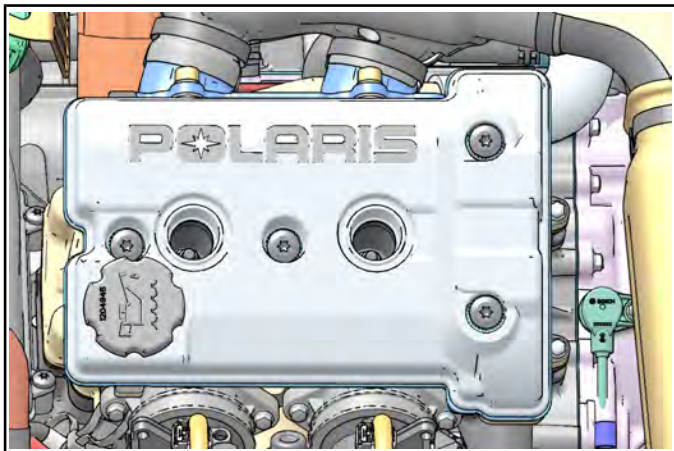

6. Remove the four T40 bolts retaining the valve cover.

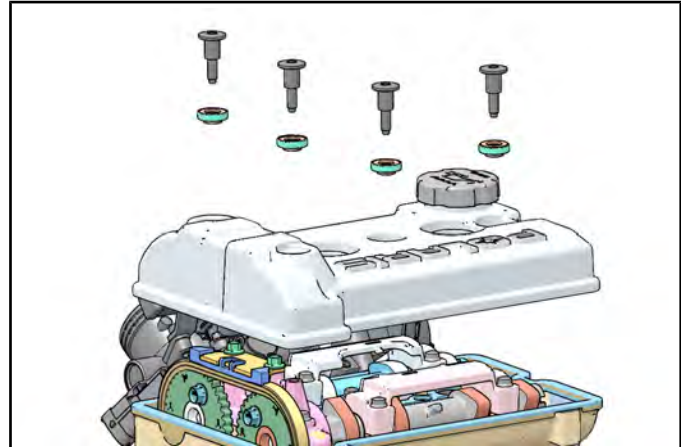

7. The engine will need to be rotated four times to inspect all eight valve clearances (Item 13). Two valves can be measured at each camshaft lobe position.

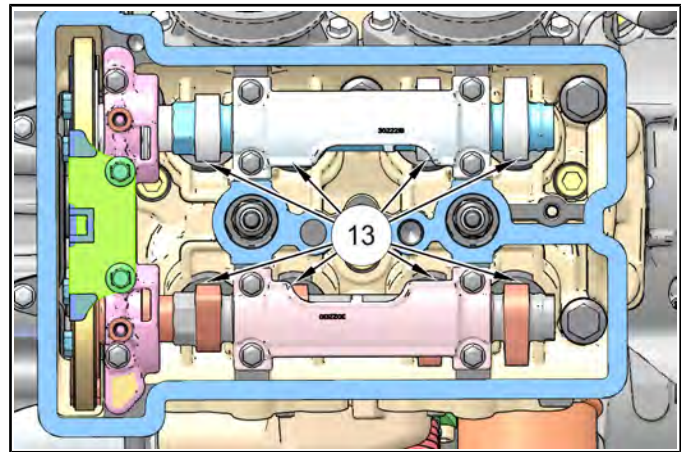

**NOTE:** Remove spark plugs to aid engine rotation.

# MAINTENANCE

8. Rotate the drive clutch counter-clockwise until the cam lobes (Item 14) above the valves you are inspecting are facing up.

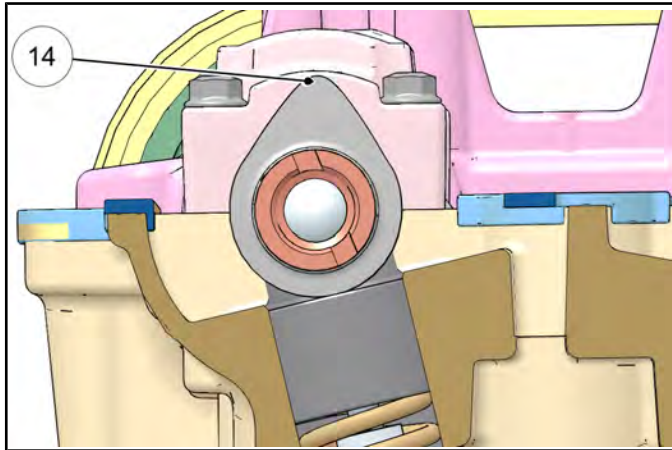

9. Measure the valve clearance using a feeler gauge.

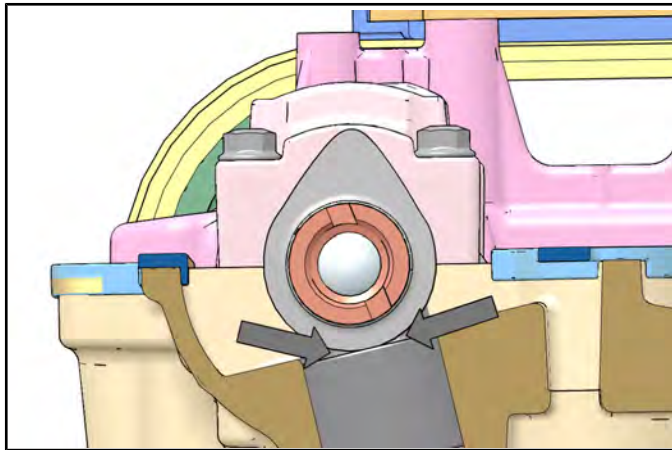

10. If the valve clearance is out of specification, proceed to "Valve Clearance Adjustment" (see Chapter 3).

<p>= In. / mm.</p>
<p>Intake Valve Clearance (cold):  <b>.006 ± .002" (0.15 ± 0.05 mm)</b></p> <p>Exhaust Valve Clearance (cold):  <b>.008 ± .002" (0.20 ± 0.05 mm)</b></p>

11. Repeat steps 18-20 until all eight valves have been inspected.

12. If previously removed, apply anti-seize compound to the spark plug threads and reinstall the spark plugs. Torque spark plugs to specification.

= T
<p>Spark Plug Torque:  <b>7 ft-lbs (10 Nm)</b></p>

13. Inspect the valve cover seal and replace if necessary.

14. Install **NEW** isolators on the valve cover bolts. Install the valve cover and the four T40 bolts. Torque bolts to specification.

= T
<p>Valve Cover Bolts:  <b>7 ft-lbs (10 Nm)</b></p>

15. Install the spark plug wires back into their correct location.

16. Install the push rivet that retains the heat shield to the frame cross member.

17. Install the spark plug wires. Ensure wires are installed on their proper cylinder spark plug and pushed down all the way so they engage onto the spark plugs.

**NOTE: The engine will misfire if the spark plug wires are installed incorrectly. The spark plug wires are marked with PTO and MAG and should be installed to the corresponding cylinder.**

18. Install outer clutch cover and eight retaining screws. Torque screws to specification.

= T
<p>Outer Clutch Cover Screws:  <b>50 in-lbs (5 Nm)</b></p>

19. Connect the negative (-) battery cable to the battery and install the seat.

20. Start the engine to ensure proper operation.

21. Install the engine access panel.

## TRANSMISSION AND FRONT GEARCASE

### Specification Chart

GEARCASE	LUBRICANT	CAPACITY	FILL / DRAIN PLUG TORQUE
Transmission	AGL	44 oz. (1300 ml)	<b>14 ft-lbs (19 Nm)</b>
Front Gearcase	Demand Drive	8.5oz. (250 ml)	<b>10 ft-lbs (14 Nm)</b>

2

### Transmission Lubrication

**NOTE:** It is important to follow the transmission maintenance intervals described in the Periodic Maintenance Chart. Regular lubricant level inspections should be performed as well.

The transmission lubricant level should be checked and changed in accordance with the maintenance schedule.

- Be sure vehicle is positioned on a level surface when checking or changing the lubricant.
- Check vent hose to be sure it is routed properly and unobstructed.

### Transmission Lubricant Level Check

The fill plug is located on the rear portion of the transmission gearcase. Access the fill plug at the rear of the vehicle. Maintain lubricant level even with the bottom of the fill plug hole.

1. Position vehicle on a level surface.
2. Remove the fill plug (Item 1) and check the lubricant level (Item 2).

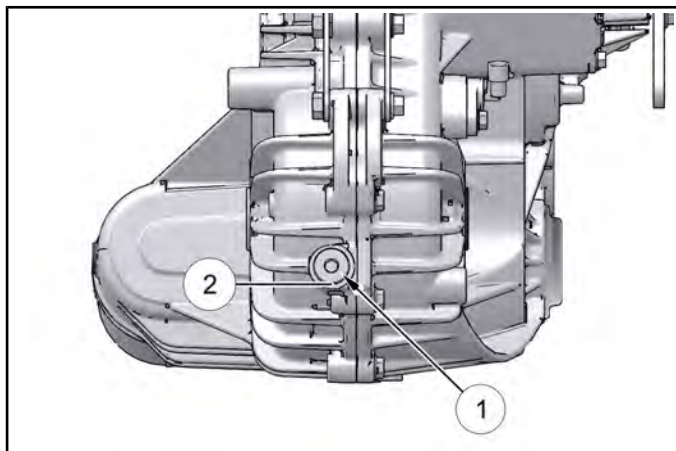

3. If lubricant level is not even with bottom threads, add recommended lubricant as needed. Do not overfill.

4. Reinstall the fill plug and torque to specification.

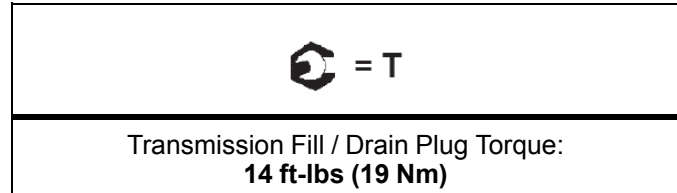

### Transmission Lubricant Change

The drain plug is located on the bottom of the transmission gearcase. Access the drain plug through the drain hole in the skid plate.

5. Remove the fill plug (refer to "Transmission Lubricant Level Check").
6. Place a drain pan under the transmission drain plug.
7. Remove drain plug (Item 3) and allow lubricant to drain completely.

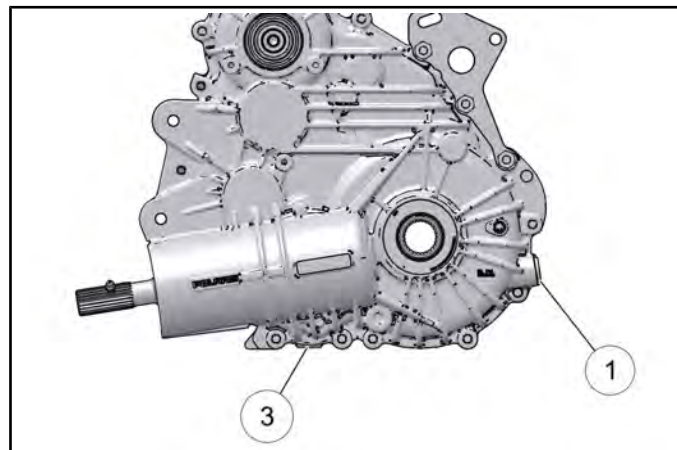

8. Clean the drain plug magnetic surface.
9. Reinstall the drain plug and torque to specification.

# MAINTENANCE

10. Add the recommended amount of lubricant through the fill plug hole. Maintain the lubricant level at the bottom of the fill plug hole when filling the transmission. Do not overfill.

<b>Recommended Transmission Lubricant:</b> AGL (PN 2878068) (Quart) <b>Capacity:</b> 44 oz. (1300 ml) <b>Capacity (INT'L):</b> 41 oz. (1200 ml)

11. Reinstall the fill plug and torque to specification.

Transmission Fill / Drain Plug Torque: <b>14 ft-lbs (19 Nm)</b>

12. Check for leaks. Dispose of used lubricant properly.

## Front Gearcase Lubrication

**NOTE:** It is important to follow the front gearcase maintenance intervals described in the Periodic Maintenance Chart. Regular fluid level inspections should be performed as well.

The front gearcase fluid level should be checked and changed in accordance with the maintenance schedule.

- Be sure vehicle is positioned on a level surface when checking or changing the fluid.
- Check vent hose to be sure it is routed properly and unobstructed.

### Front Gearcase Fluid Level Check

The fill plug is located on the bottom right side of the front gearcase. Access the fill plug through the right front wheel well. Maintain fluid level even with the bottom of the fill plug hole.

1. Position vehicle on a level surface.

2. Remove the fill plug (Item 1) and check the fluid level.

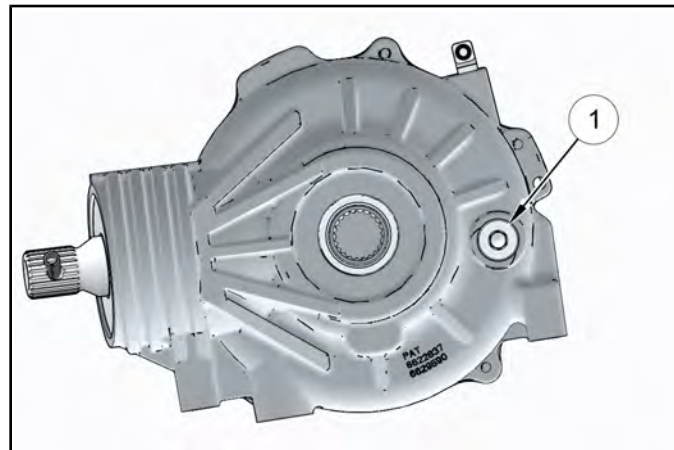

3. If fluid level is not even with the bottom threads, add the recommended fluid as needed. Do not overfill.
4. Reinstall the fill plug and torque to specification.

Front Gearcase Fill / Drain Plug Torque: <b>10 ft-lbs (14 Nm)</b>

### Front Gearcase Fluid Change:

The drain plug is located on the bottom of the front gearcase. Access the drain plug through the access hole in the frame underneath the front gearcase.

5. Remove the fill plug (refer to "Front Gearcase Fluid Level Check").
6. Place a drain pan under the front gearcase drain plug.
7. Remove the drain plug (Item 2) and allow fluid to drain completely.

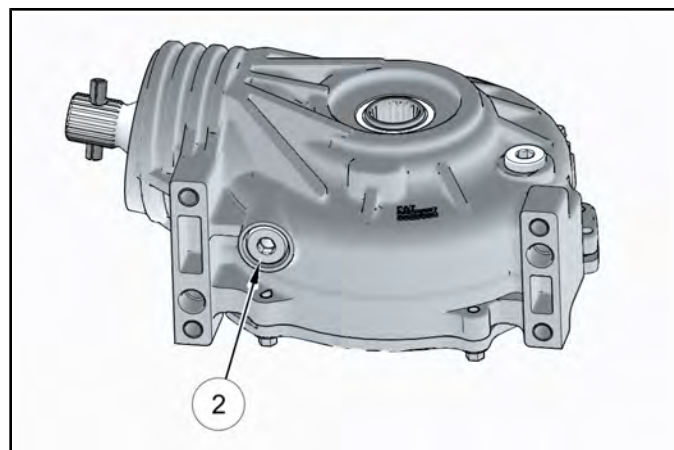

8. Clean the drain plug magnetic surface.
9. Reinstall the drain plug and torque to specification.
10. Add the recommended amount of fluid through the fill hole. Maintain the fluid level even with the bottom threads of the fill plug hole.

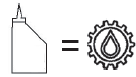
<p><b>Recommended Front Gearcase Fluid:</b> Polaris Demand Drive (PN 2877922) (Quart) <b>Capacity:</b> □ 8.5 oz. (250 mL)</p>

11. Reinstall the fill plug and torque to specification.

<p>Front Gearcase Fill / Drain Plug Torque: <b>10 ft-lbs (14 Nm)</b></p>

12. Check for leaks. Dispose of used fluid properly.

## COOLING SYSTEM

### Cooling System Overview

The engine coolant level is controlled, or maintained, by the recovery system. The recovery system components are the recovery bottle, radiator filler neck, radiator pressure cap and connecting hose.

As coolant operating temperature increases, the expanding (heated) excess coolant is forced out of the radiator past the pressure cap and into the recovery bottle. As engine coolant temperature decreases the contracting (cooled) coolant is drawn back up from the tank past the pressure cap and into the radiator.

**NOTE: Some coolant level drop on new machines is normal as the system is purging itself of trapped air. Observe coolant levels often during break-in period.**

**Overheating of engine could occur if air is not fully purged from system.**

**Polaris Premium 60/40 Antifreeze is premixed and ready to use. Do not dilute with water.**

### Coolant Strength

Test the strength of the coolant using an antifreeze hydrometer.

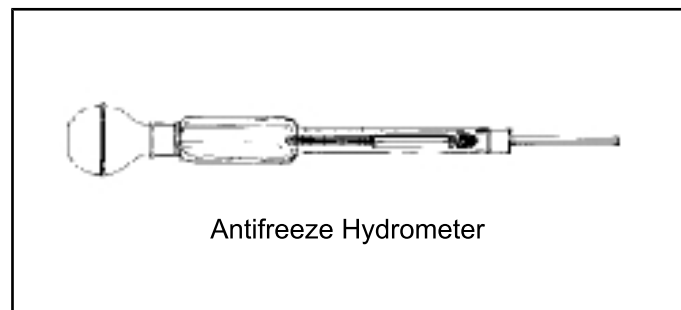

Antifreeze Hydrometer

- A 50/50 or 60/40 mixture of antifreeze and distilled water will provide the optimum cooling, corrosion protection, and antifreeze protection.
- Do not use tap water, straight antifreeze or straight water in the system. Tap water contains minerals and impurities which build up in the system.
- Straight water or antifreeze may cause the system to freeze, corrode, or overheat.

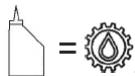
<p><b>Recommended Coolant:</b> Polaris Premium Pre-Mixed Antifreeze (PN 2871534) (Quart) (PN 2871323) (Gallon)</p>

# MAINTENANCE

## Coolant Level Inspection

The pressure cap (Item 1) and recovery bottle (Item 2) are located under the front hood of the vehicle. The coolant level must be maintained between the minimum and maximum levels indicated on the recovery bottle.

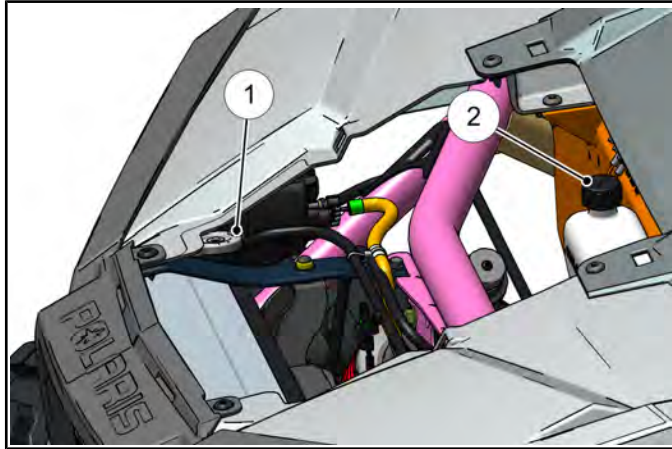

With the engine at operating temperature, the coolant level should be between the upper and lower marks on the coolant recovery bottle. If not, perform the following procedure:

1. Position the vehicle on a level surface.
2. Remove the front hood.
3. View the coolant level in the recovery bottle.
4. If the coolant level is below the MIN line, inspect the coolant level in the radiator.

**NOTE: If overheating is evident, allow system to cool completely and check coolant level in the radiator and inspect for signs of trapped air in system.**

### WARNING

Never remove the pressure cap when the engine is warm or hot. Escaping steam can cause severe burns. The engine must be cool before removing the pressure cap.

5. Remove the pressure cap. Using a funnel, add coolant to the top of the filler neck.
6. Reinstall the pressure cap.

**NOTE: Use of a non-standard pressure cap will not allow the recovery system to function properly.**

7. Remove recovery bottle cap and add coolant using a funnel.

8. Fill recovery bottle to MAX level with recommended coolant or 50/50 or 60/40 mixture of antifreeze and distilled water as required for freeze protection in your area.



**Recommended Coolant:**  
Polaris Premium Pre-Mixed Antifreeze

PN 2871534 (Quart)  
PN 2871323 (Gallon)

9. Reinstall the recovery bottle cap.
10. If coolant was required, start engine and check for leaks. Make sure radiator fins are clean to prevent overheating.

## Cooling System Pressure Test

Refer to ENGINE COOLING SYSTEM, page 3.13.

## Cooling System Hoses

1. Inspect all vehicle hoses for cracks, deterioration, abrasion or leaks. Replace if necessary.

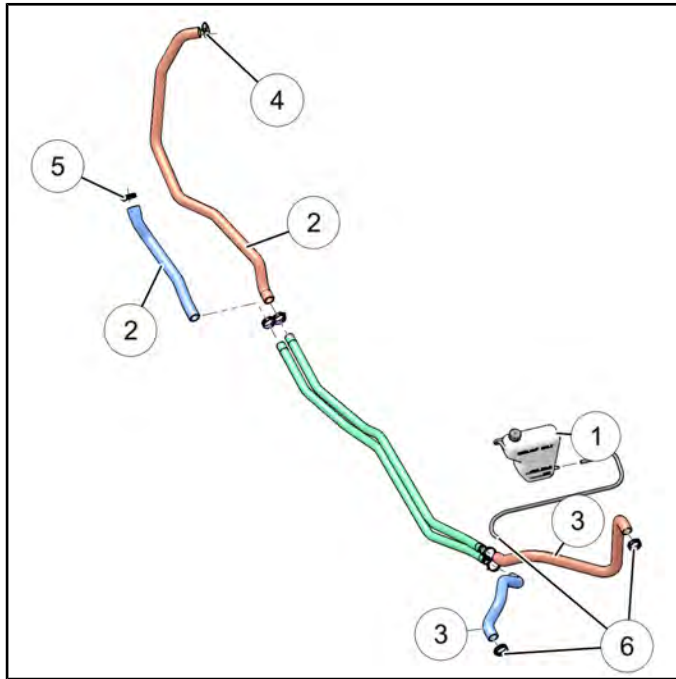

ITEM	DESCRIPTION
1	Recovery Bottle
2	Engine Hoses
3	Radiator Hoses
4	To Thermostat Housing
5	To Waterpump
6	To Radiator

2. Inspect all engine hoses for cracks, deterioration, abrasion or leaks. Replace if necessary.

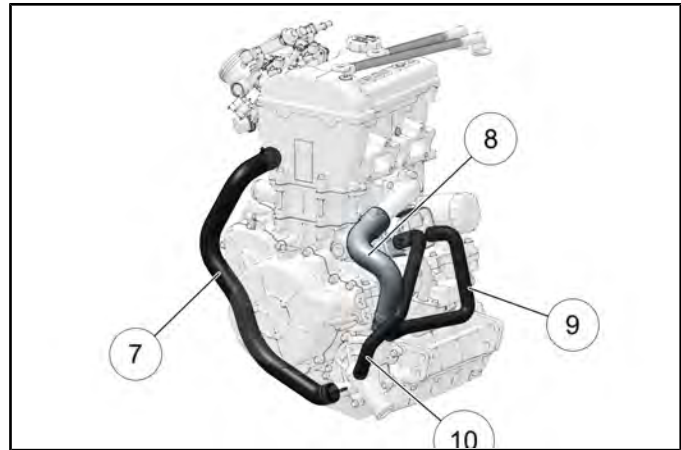

ITEM	DESCRIPTION
7	Bypass Hose
8	Waterpump Outlet Hose
9	Oil Cooler Inlet Hose
10	Oil Cooler Outlet Hose

3. Check tightness and condition of all hose spring clamps. Replace if necessary.

2



# MAINTENANCE

## Radiator Inspection / Cleaning

1. Check radiator air passages for restrictions or damage.

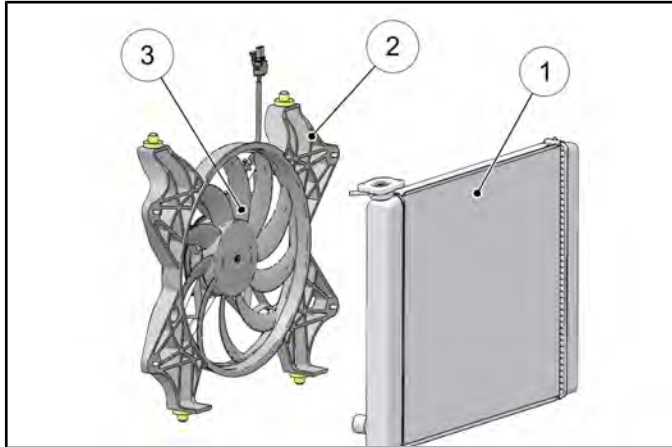

ITEM	DESCRIPTION
1	Radiator
2	Shroud
3	Fan

2. Carefully straighten any bent radiator fins.
3. Remove any obstructions with low pressure compressed air or low pressure water.

### CAUTION

Washing the vehicle with a high-pressure washer could damage the radiator fins and impair the radiators effectiveness. Use of a high-pressure washer is not recommended.

## Coolant Drain / Fill

1. Remove the front hood.

### WARNING

Never drain the coolant when the engine and radiator are warm or hot. Hot coolant can cause severe burns. Allow engine and radiator to cool.

2. Slowly remove the pressure cap to relieve any cooling system pressure.
3. Place a suitable drain pan underneath the radiator fitting on the front right side of the vehicle.
4. Drain the coolant from the radiator by removing the lower coolant hose from the radiator as shown (Item 1).

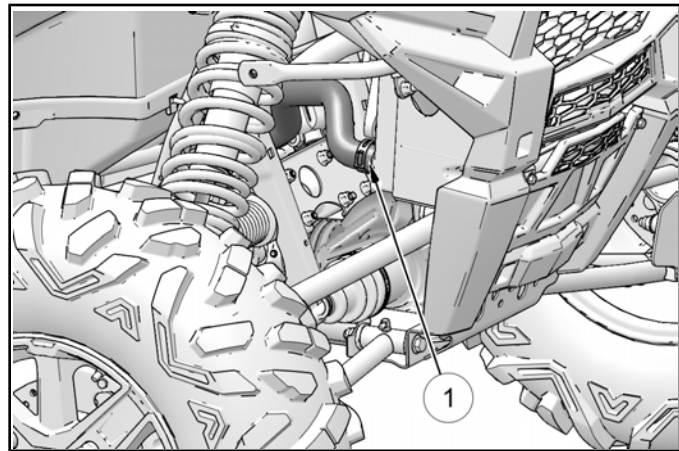

5. Allow coolant to drain completely. Properly dispose of the used coolant.
6. Reinstall coolant hose and reposition the spring clamp.
7. Remove the pressure cap. Using a funnel, add the recommended coolant to the top of the filler neck and fill the recovery bottle to the MAX level.
8. Refer to Cooling System Bleeding Procedure, page 3.18.

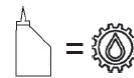

**Recommended Coolant:**  
 Polaris Premium Pre-Mixed Antifreeze  
 (PN 2871534) (Quart)  
 (PN 2871323) (Gallon)

## PVT / FINAL DRIVE / WHEEL AND TIRE

### Drive Clutch / Driven Clutch / Belt Service

Refer to PVT SYSTEM SERVICE, page 6.6 for service and removal procedures.

### PVT Intake Pre-Filter Service

It is recommended that the PVT intake pre-filter be inspected daily. The filter should be inspected using the following procedure:

1. The PVT intake pre-filter is located just above the left rear wheel fender.
2. Loosen the knob on top of the assembly and lift up to disengage the tab from the cargo box.

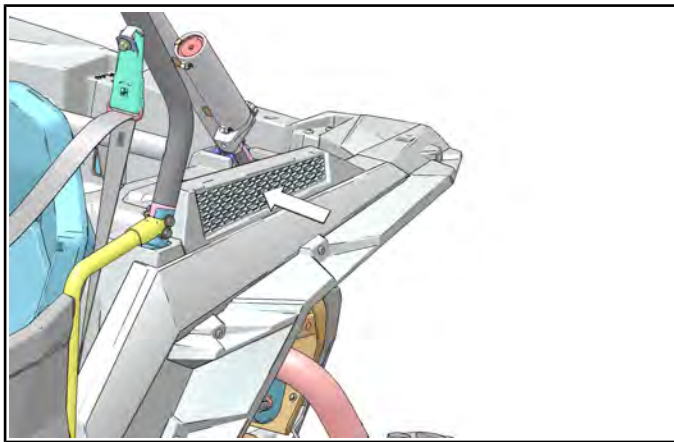

3. Inspect the pre-filter. If necessary, clean with soapy water and dry with low pressure compressed air.

### PVT Drying

**NOTE:** After operating in water, the vehicle's PVT system should be checked immediately. Use the following instructions to dry it out before operating.

The PVT drain plug is located at the bottom of the outer clutch cover. Access the drain plug through the left rear wheel well.

1. Using a flat blade screwdriver, remove the PVT drain plug (Item 1) and O-ring from the outer clutch cover.

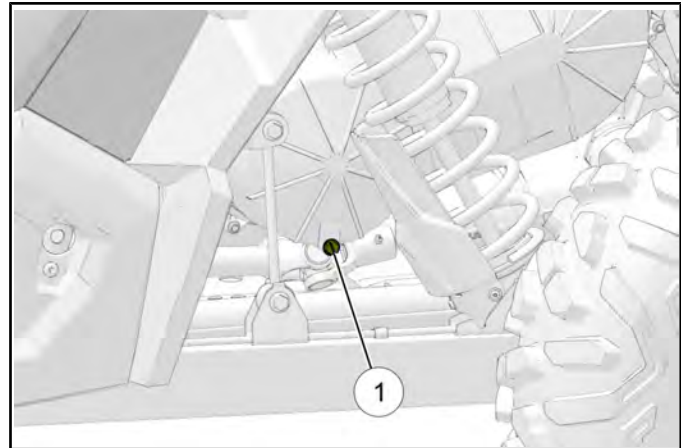

2. Allow the water to drain out completely.
3. Reinstall the drain plug and O-ring.
4. Place the transmission in PARK, apply the brake and start the engine.
5. Apply varying throttle for 10-15 seconds to expel the moisture and air-dry the belt and clutches.

**NOTE:** Do not hold the throttle pedal wide open for more than 5 seconds.

6. Allow the engine RPM to return to idle, then shift the transmission into low gear.
7. Test the PVT system for belt slippage. If the belt slips, repeat the process or remove the outer clutch cover to inspect the PVT system (see PVT SYSTEM SERVICE, page 6.6 for service and removal procedures).

**NOTE:** If the vehicle has ingested a large amount of water into the PVT system and has not been operated for a period of time, be sure to check the PVT system components for water damage.

# MAINTENANCE

## Drive Shaft Boot Inspection

Inspect the front and rear drive shaft boots (Item 1) for damage, tears, wear or leaking grease. If the boots exhibit any of these symptoms, they should be replaced. Check to see the boot clamps (Item 2) are properly positioned. Refer to DRIVE SHAFT CV JOINT / BOOT REPLACEMENT , page 7.33 for drive shaft boot replacement.

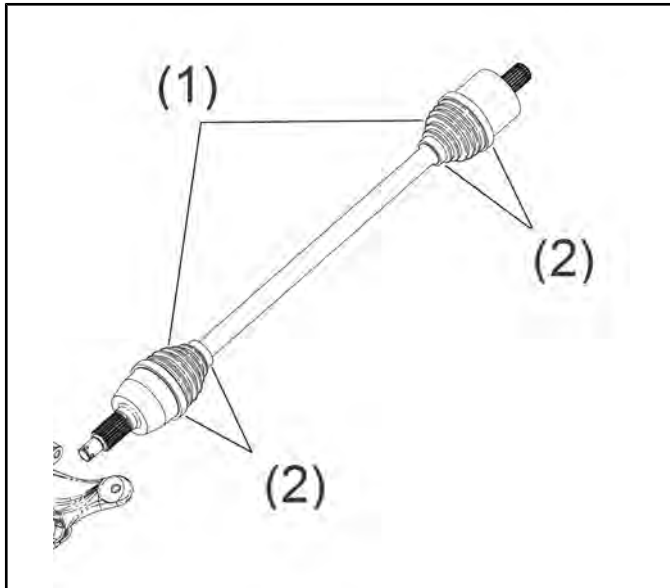

## Wheel and Hub Torque Table

ITEM	SPECIFICATION
Wheel Nuts (Cast Aluminum Wheels)	<b>120 ft-lbs (163 Nm)</b>
Hub Retaining Nuts (Front and Rear)	<b>110 ft-lbs (149 Nm)</b>

**NOTE:** Do not lubricate the stud or the lug nut.

## Wheel Removal

1. Position the vehicle on a level surface.
2. Place the transmission in PARK and stop the engine.
3. Loosen the wheel nuts slightly. If wheel hub removal is required, remove the wheel cap, cotter pin and loosen the hub nut slightly.
4. Elevate the appropriate side of the vehicle by placing a suitable stand under the frame.
5. Remove the wheel nuts and remove the wheel.

## Wheel Installation

1. Verify the transmission is still in PARK.
2. Place the wheel in the correct position on the wheel hub (Item 5). Be sure the valve stem (Item 2) is toward the outside and rotation arrows on the tire point toward forward rotation.
3. Attach the wheel nuts (Item 1) and finger tighten them.
4. Carefully lower the vehicle to the ground.
5. Torque the wheel nuts and/or hub nut (Item 3) to the proper torque specification (see Wheel and Hub Torque Table, page 2.28).
6. If hub nut was removed, install a new cotter pin (Item 4) after the hub nut has been tightened. If the holes do not line up, turn the hub nut counter-clockwise until the cotter pin can be installed.

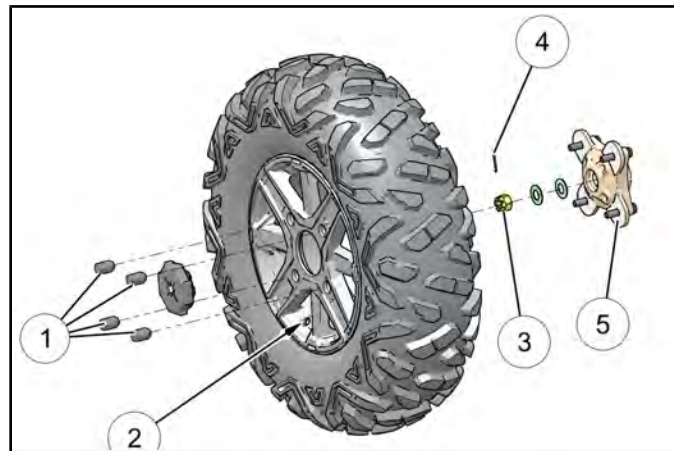

### CAUTION

If wheels are improperly installed it could affect vehicle handling and tire wear. On vehicles with tapered wheel nuts, make sure tapered end of nut goes into taper on wheel.

## Tire Inspection

- Improper tire inflation may affect vehicle maneuverability.
- When replacing a tire always use original equipment size and type.
- The use of non-standard size or type tires may affect vehicle handling.

 **WARNING**

Operating with worn tires will increase the possibility of the vehicle skidding easily with possible loss of control.

Worn tires can cause an accident.

Always replace tires when the usable tread depth has worn out.

## Tire Pressure

Remove the valve stem cap and check tire pressure using the tire pressure gauge included in the vehicle's tool kit.

**CAUTION**

Maintain proper tire pressure.  
Refer to the warning tire pressure decal applied to the vehicle.

**TIRE PRESSURE INSPECTION (COLD)**

Front	Rear
16 psi (110 kPa)	16 psi (110 kPa)

## ELECTRICAL AND IGNITION SYSTEM

### Battery Maintenance

Keep battery terminals and connections free of corrosion. If cleaning is necessary, remove the corrosion with a stiff wire brush. Wash with a solution of one tablespoon baking soda and one cup water. Rinse well with tap water and dry off with clean shop towels. Coat the terminals with dielectric grease or petroleum jelly.

2

 **WARNING**

**CALIFORNIA PROPOSITION 65 WARNING:**

Batteries, battery posts, terminals and related accessories contain lead and lead compounds, and other chemicals known to the State of California to cause cancer and birth defects or other reproductive harm.

WASH HANDS AFTER HANDLING.

 **WARNING**

Battery electrolyte is poisonous. It contains sulfuric acid. Serious burns can result from contact with skin, eyes or clothing. Antidote:

**External:** Flush with water.

**Internal:** Drink large quantities of water or milk. Follow with milk of magnesia, beaten egg, or vegetable oil. Call physician immediately.

**Eyes:** Flush with water for 15 minutes and get prompt medical attention.

Batteries produce explosive gases. Keep sparks, flame, cigarettes, etc. away. Ventilate when charging or using in an enclosed space. Always shield eyes when working near batteries.

KEEP OUT OF REACH OF CHILDREN.

**NOTE:** Batteries must be fully charged before use or battery life will be reduced by 10-30% of full potential. Charge battery according to "Charging Procedure", page 10.36. Do not use the vehicle's stator/alternator to charge a new battery.

# MAINTENANCE

## Battery Charging / Off Season Storage

Refer to Charging Procedure , page 10.36 and Battery Off Season Storage, page 10.35.

## Battery Removal

1. Remove the driver's seat to access the battery (Item 1).

**NOTE: Battery is located under left rear seat on RZR XP 4 1000**

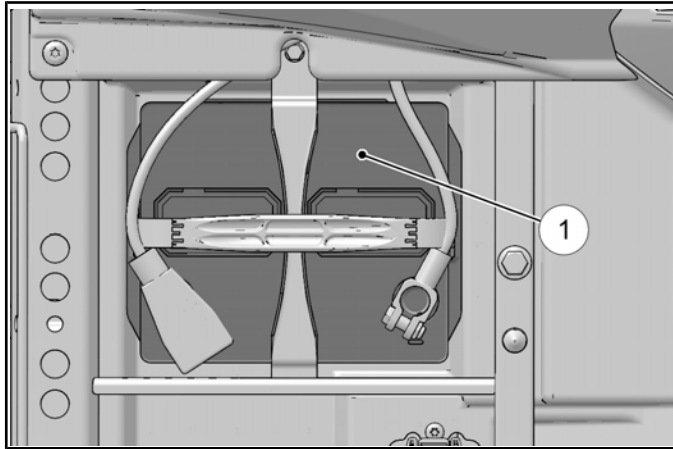

2. Disconnect the black (negative) battery cable(s).
3. Disconnect the red (positive) battery cable(s).

### CAUTION

To reduce the chance of sparks: Whenever removing the battery, disconnect the black (negative) cable first. When reinstalling the battery, install the black (negative) cable last.

4. Remove the battery hold-down bracket (Item 2).

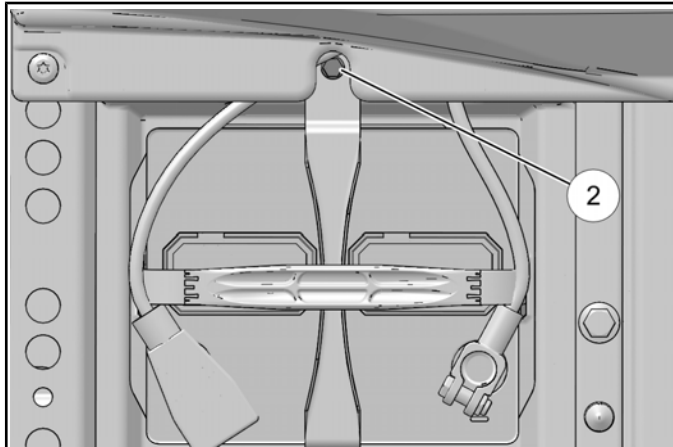

5. Lift the battery out of the vehicle.

## Battery Installation

**NOTE: Using a new battery that has not been fully charged can damage the battery and result in a shorter life. It can also hinder vehicle performance. Refer to Charging Procedure , page 10.36 before installing the battery.**

1. Ensure the battery is fully charged.
2. Place the battery in the battery holder and secure with hold-down strap.
3. Coat the terminals with dielectric grease or petroleum jelly.
4. Connect and tighten the red (positive) cable(s) first.
5. Connect and tighten the black (negative) cable(s) last.

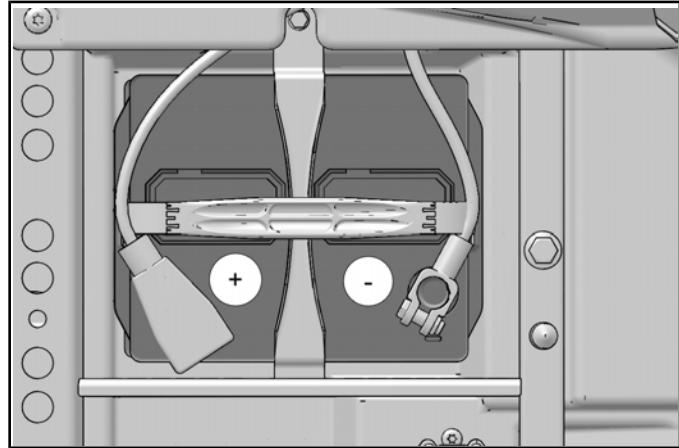

6. Verify that cables are properly routed and reinstall the driver's seat.

## Engine / Chassis Electrical Ground

Inspect the ground cable connections. Remove ground terminals and clean if necessary.

1. The chassis ground connection (Item 1), located below the start solenoid (Item 2), can be accessed through the left rear wheel area.

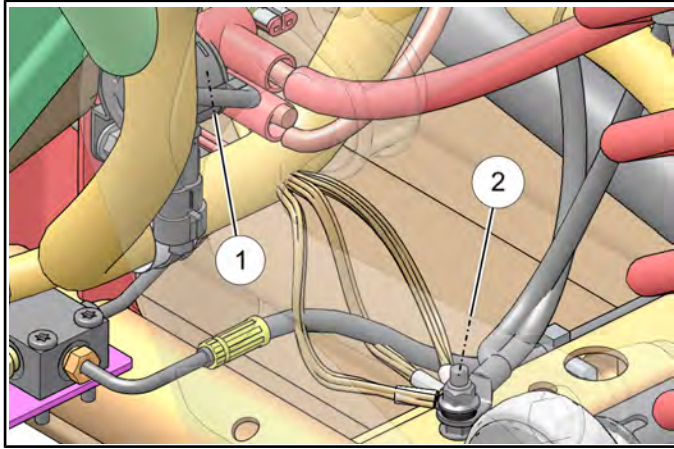

2. Inspect the chassis ground terminals. Be sure the grounds are clean and tight.

## Spark Plug Service

Inspect and replace the spark plugs at the intervals outlined in the Periodic Maintenance Chart.

1. Remove the cargo box access panel (Item 1).

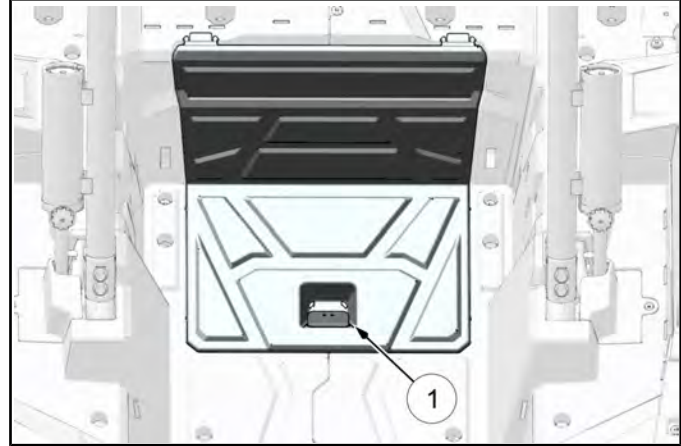

### WARNING

A hot engine can cause serious burns. Allow engine to cool or wear protective gloves when removing the spark plugs.

2. Remove both spark plug caps (Item 2).

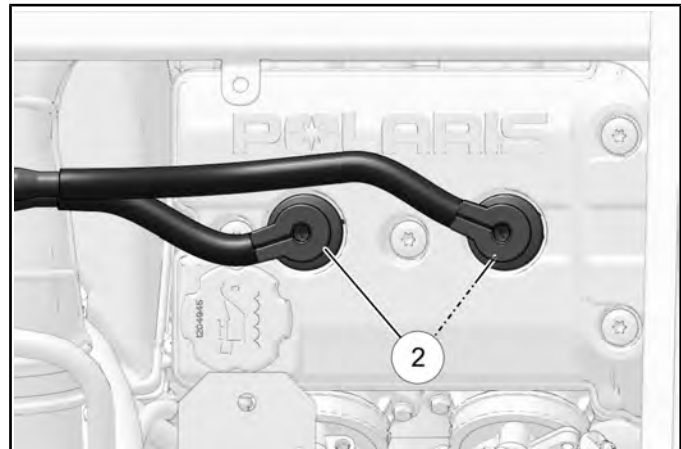

**NOTE:** Note MAG and PTO reference decals on spark plug wires for reassembly.

3. Clean out plug wells with compressed air to remove any loose dirt or debris.
4. Rinse plug wells with water and dry with compressed air.

**NOTE:** Spark plug wells have drain holes built into the cylinder head to allow water to drain out.

## MAINTENANCE

- Remove spark plugs using a 5/8" spark plug socket with an extension.
- Inspect electrodes for wear and carbon buildup. Look for a sharp outer edge with no rounding or erosion of the electrodes.

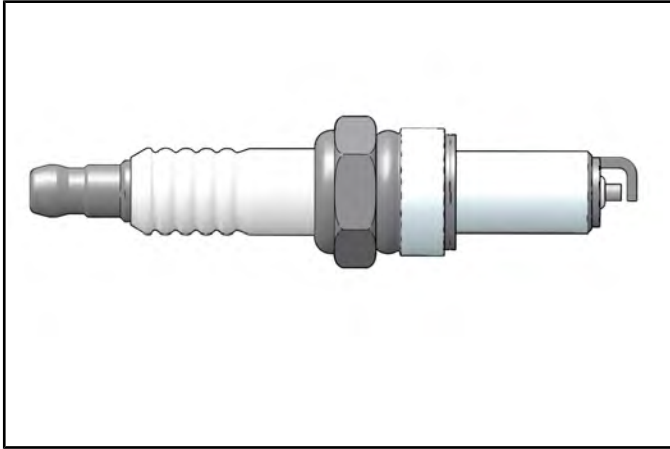

- Clean with electrical contact cleaner or a glass bead spark plug cleaner only. **CAUTION:** A wire brush or coated abrasive should not be used.
- Measure gap with a wire gauge. Adjust gap if necessary by carefully bending the side electrode.
- If necessary, replace spark plug with proper type. **CAUTION:** Severe engine damage may occur if the incorrect spark plug is used.

**Recommended Spark Plug:  
Champion RG4YCX**

- Apply anti-seize compound to the spark plug threads.
- Install spark plugs and torque to specification.



**Spark Plug Torque:  
7 ft-lbs (10 Nm)**

- Install the plug caps to the appropriate cylinder by referencing the MAG and PTO spark plug wire decals. Ensure wires are pushed down all the way so they engage onto the spark plugs.
- Reinstall the cargo box access panel.

## STEERING

### Steering Inspection

The steering components should be checked periodically for loose fasteners, worn tie rod ends, ball joints and damage. Also check to make sure all cotter pins are in place. If cotter pins are removed, they must be replaced.

Replace any worn or damaged steering components. Steering should move freely through the entire range of travel without binding. Check routing of all cables, hoses, and wiring to be sure the steering mechanism is not restricted or limited.

**NOTE:** Check front end alignment whenever steering components are replaced.

### **WARNING**

Due to the critical nature of the procedures outlined in this chapter, Polaris recommends steering component repair and adjustment be performed by an authorized Polaris MSD certified technician.

### Steering Wheel Freeplay

Check steering wheel for specified freeplay and operation.

- Position the vehicle on level ground.
- Lightly turn the steering wheel left and right.
- There should be 0.8-1.0" (20-25 mm) of freeplay.
- If there is excessive freeplay or the steering feels rough, inspect the following components.
  - Tie Rod Ends (Item 1)
  - Steering Shaft U-Joints (Item 2)
  - Steering Gearbox (Item 3)

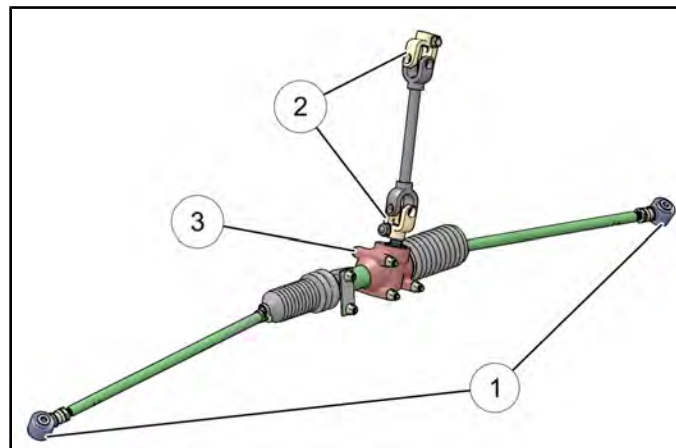

## Tie Rod End / Wheel Hub Inspection

- To check for play in the tie rod end, grasp the steering tie rod, pull in all directions feeling for movement.

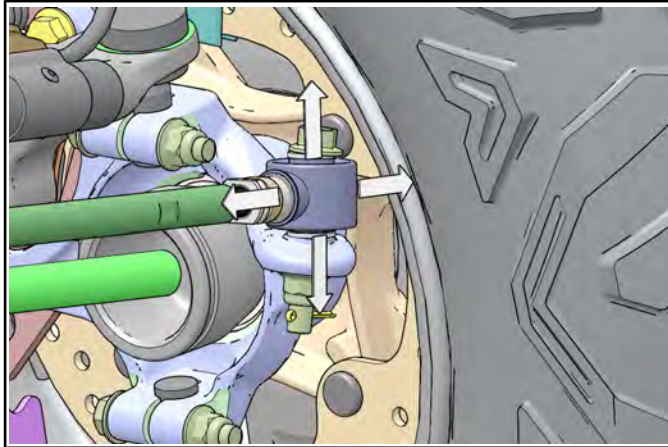

- Replace any worn steering components. Steering should move freely through entire range of travel without binding.
- Elevate front end of machine so front wheels are off the ground. Check for any looseness in front wheel/hub assembly by grasping the tire firmly at top and bottom first, and then at front and rear. Try to move the wheel and hub by pushing inward and pulling outward.

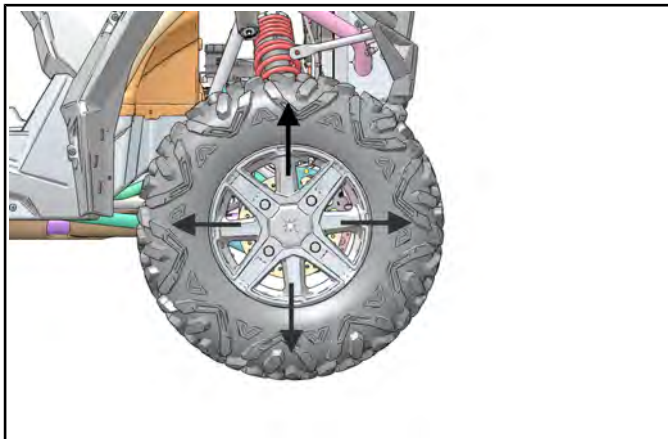

- If abnormal movement is detected, inspect the hub and wheel assembly to determine the cause (loose wheel nuts or loose front hub nut).
- Refer to Chapter 7 "Final Drive" for front hub service procedures.

## Wheel Toe Alignment Inspection

- Place machine on a smooth level surface and set steering wheel in a straight ahead position. Secure the steering wheel in this position.
- Place a chalk mark on the center line of the front tires approximately 10" (25.4 cm) from the floor or as close to the hub/axle center line as possible (1).

2

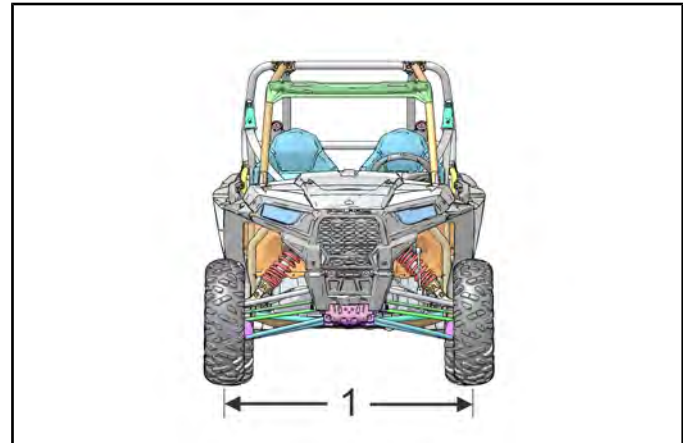

**NOTE:** It is important the height of both marks be equally positioned to get an accurate measurement.

- Measure the distance between the marks and record the measurement. Call this measurement "2".

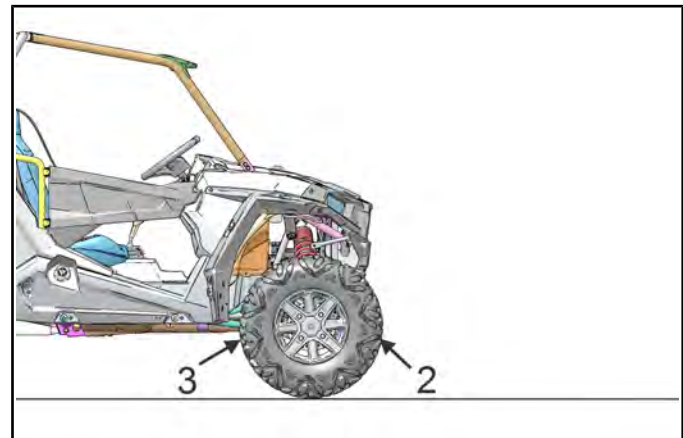

- Rotate the tires 180° by moving the vehicle forward. Position chalk marks facing rearward, even with the hub/axle center line.



# MAINTENANCE

5. Again measure the distance between the marks and record. Call this measurement "3". Subtract measurement "3" from measurement "2". The difference between measurements "2" and "3" is the vehicle toe alignment. The recommended vehicle toe tolerance is 1/8 to 3/16" (3.2 to 4.8 mm) toe out. This means the measurement at the front of the tire (2) is 1/8 to 3/16" (3.2 to 4.8 mm) wider than the measurement at the rear (3).

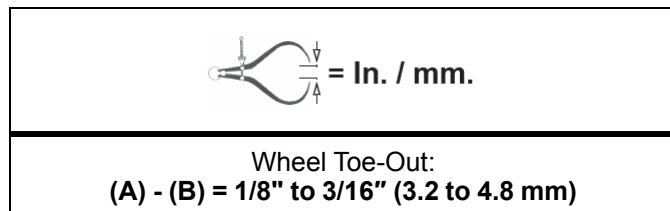

## Wheel Toe Adjustment

If toe alignment is incorrect, repeat steps 3-5 of "Wheel Toe Alignment Inspection", but instead measure the distance between each wheel and the vehicle center. This will tell you which tie rod needs adjusting.

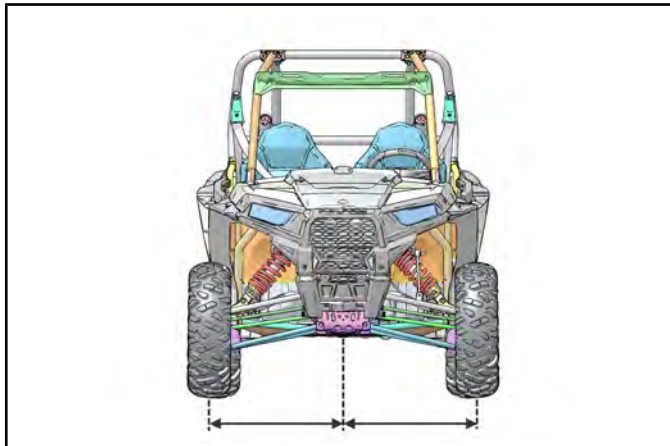

**NOTE:** Be sure steering wheel is straight ahead before determining which tie rod needs adjustment.

### CAUTION

During tie rod adjustment, it is very important that the following precautions be taken when tightening tie rod end jam nuts.

If the rod end is positioned incorrectly it will not pivot, and may break.

#### To adjust toe alignment:

- Hold tie rod end to keep it from rotating.
- Loosen jam nuts at both end of the tie rod.

- Shorten or lengthen the tie rod until alignment is as required to achieve the proper toe setting as specified in "Wheel Toe Alignment".
- **IMPORTANT:** When tightening the tie rod end jam nuts, the rod ends must be held parallel to prevent rod end damage and premature wear. Damage may not be immediately apparent if done incorrectly.
- After alignment is complete, torque jam nuts to specification.



Tie Rod Jamb Nut:  
**14 ft-lbs (19 Nm)**

## SUSPENSION (WALKER EVANS™)

### Spring Adjustment

The front and rear shocks have a ride height adjustment. Suspension springs may be adjusted to suit different riding conditions or vehicle payloads.

#### WARNING

Uneven adjustment may cause poor handling of the vehicle, which could result in an accident and serious injury or death. Always adjust both the left and right spring equally.

### Spring Adjustment - Factory Setting

FRONT	REAR
RZR XP 1000: 18.618" (47.289 cm)	RZR XP 1000: 22.930" (58.242 cm)
RZR XP 4 1000: 17.593" (44.686 cm)	RZR XP 4 1000: 22.418" (56.941 cm)

**NOTE:** Refer to the shock illustrations within this procedure for spring measurement location.

The factory setting is appropriate for nearly all riding conditions. Since this vehicle is equipped with full skid plates, adjustment is not necessary.

If desired, the spring setting may be adjusted to maintain vehicle clearance height when carrying loads.

1. Raise and safely support front or rear of the vehicle off the ground to allow the suspension to fully extend.

2. Using the shock spanner/spreader tool (PN 2878925) included in the vehicle's tool kit, turn the adjustment collar (Item 1) to increase or decrease ride height.

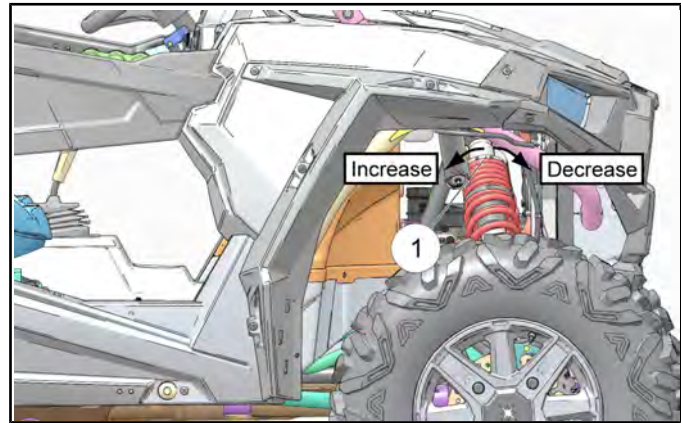

**Shock Spanner / Clutch Spreader Tool:  
PN 2878925**

**NOTE:** DO NOT increase the spring adjustment by more than one inch (25.4 mm) over the factory setting.

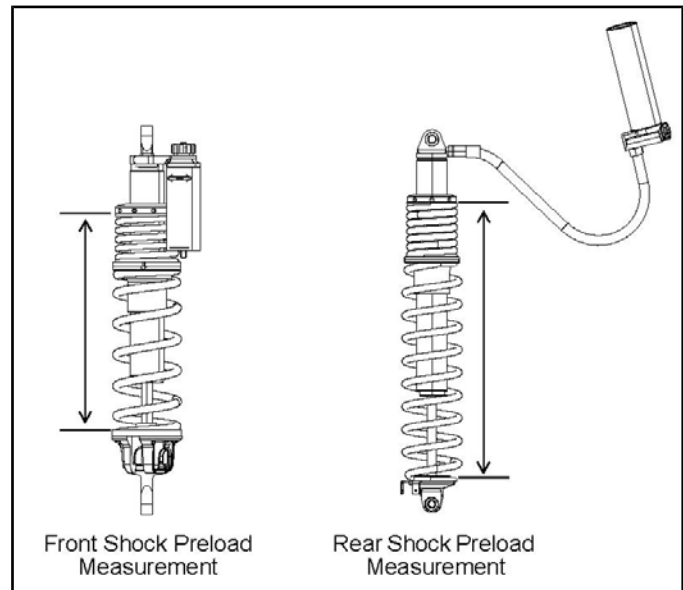

**NOTE:** Always return the spring preload to the factory setting after the load is removed from the vehicle. The increased suspension height will negatively impact vehicle stability when operating without a load.

# MAINTENANCE

## Shock Compression Adjustment

The compression damping adjustment is located on the shock 'Piggyback' reservoir of each shock. Damping adjustments can be made without using any tools.

**NOTE:** When the adjuster knob is turned counter-clockwise until it stops, the damping is in the fully open position (softest).

Turn the adjuster knob clockwise to increase compression damping. Turn the adjuster knob counter-clockwise to decrease compression damping.

**NOTE:** The recommended factory setting for the front and rear shocks are provided in the following compression adjustment tables.

**Walker Evans™ 2.0" Front Shock:  
Compression Adjustment Table**

SETTING	COMPRESSION DAMPING
Softest	Full counter-clockwise position
Factory	6 clicks from softest position
Firmer	Full clockwise position

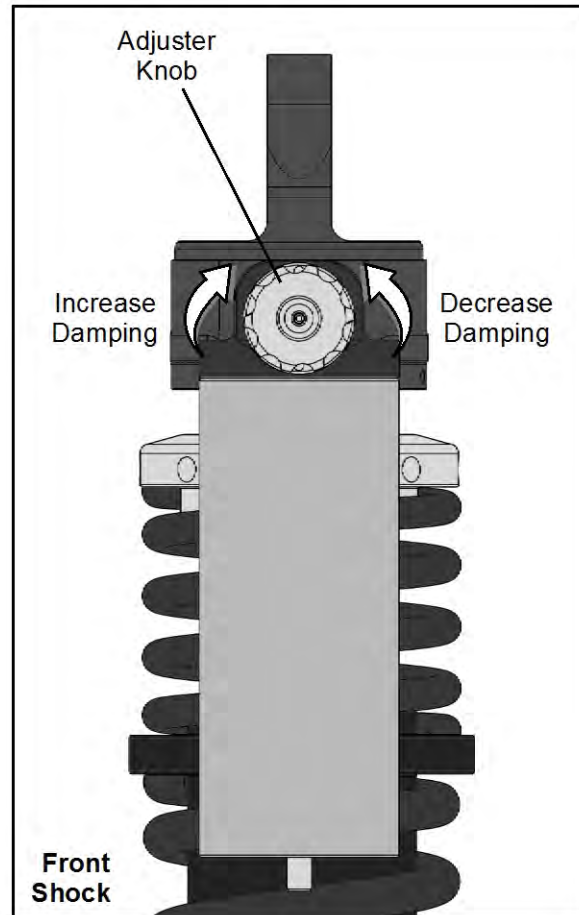

**Walker Evans™ 2.5" Rear Shock:  
Compression Adjustment Table**

SETTING	COMPRESSION DAMPING
Softest	Full counter-clockwise position
Factory	7 clicks from softest position
Firmer	Full clockwise position

The rear shock adjuster can be found on the remote reservoir. Clockwise will increase damping and counter-clockwise will decrease damping.

## **BRAKE SYSTEM**

### **Brake Fluid Inspection**

Always check the brake pedal travel and inspect the brake fluid reservoir level before each operation. If the fluid level is low, add DOT 4 brake fluid only.

Brake fluid should be changed every two years. The fluid should also be changed anytime the fluid becomes contaminated, the fluid level is below the minimum level, or if the type and brand of the fluid in the reservoir is unknown.

The brake fluid master cylinder reservoir can be accessed through the left front wheel well.

1. Position the vehicle on a level surface.
2. Place the transmission in PARK.
3. View the brake fluid level in the reservoir (Item 1). The level should be between the MAX and MIN level lines.

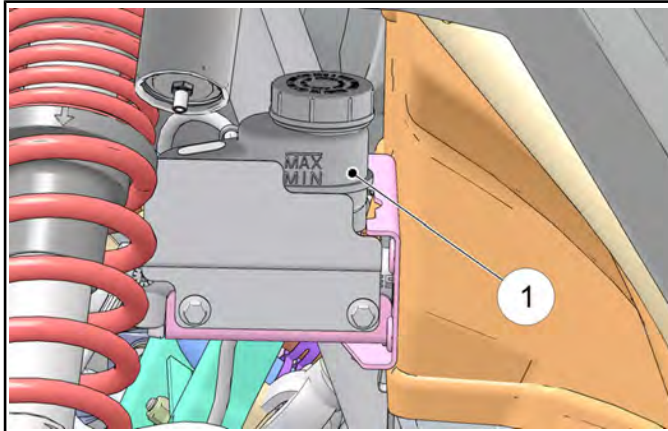

4. If the fluid level is lower than the MIN level line, add brake fluid until it reaches the MAX level line.
5. Install the reservoir cap and apply the brake pedal forcefully for a few seconds and check for fluid leakage around the master cylinder fittings and the brake caliper fittings.

### **Brake Pad / Disc Inspection**

1. Check the brake pads for wear, damage, or looseness.
2. Inspect the brake pad surface for excessive wear.
3. Pads should be changed when the friction material (Item 1) is worn to 0.040" (1 mm).

**2**

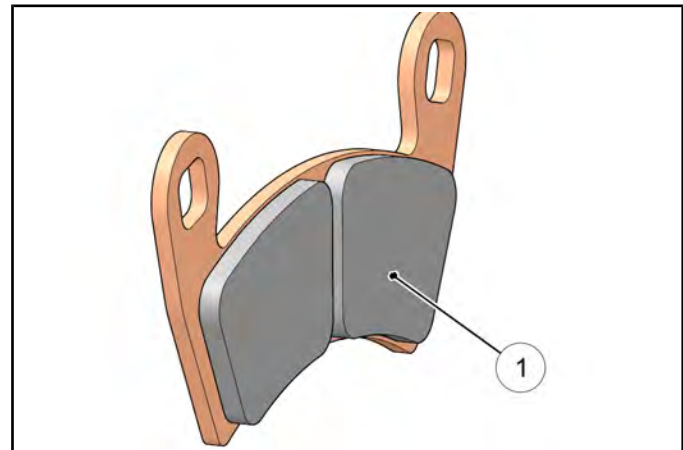

4. Check surface condition of the brake discs.
5. Measure the thickness of the front and rear brake discs.
6. The disc(s) should be replaced if thickness is less than 0.170" (4.32 mm).



### **Brake Hose and Fitting Inspection**

Check brake system hoses and fittings for cracks, deterioration, abrasion, and leaks. Tighten any loose fittings and replace any worn or damaged parts.



# CHAPTER 3

## ENGINE

GENERAL INFORMATION .....	3.3
SPECIAL TOOLS .....	3.3
ENGINE LUBRICATION SPECIFICATIONS.....	3.3
OIL PRESSURE TEST .....	3.4
ENGINE OIL FLOW CHART.....	3.5
ENGINE SERVICE SPECIFICATIONS.....	3.6
ENGINE SPECIFICATIONS .....	3.6
ENGINE DETAIL - TORQUE VALUES / SEQUENCES / ASSEMBLY NOTES .....	3.8
MAIN ENGINE COMPONENTS - TORQUE SPECIFICATION AND SEQUENCE.....	3.8
BALANCE SHAFT / CONNECTING RODS / CRANKCASE / CRANKSHAFT / PISTONS .....	3.9
CYLINDER / OIL COOLER / OIL FILTER / OIL PUMP / OIL SUMP / WATER PUMP .....	3.10
CAMSHAFTS / CYLINDER HEAD / FLYWHEEL / IDLER GEARS / STATOR COVER.....	3.11
SPARK PLUGS / STARTER / THERMOSTAT HOUSING / THROTTLE BODY / VALVE COVER ....	3.12
ENGINE COOLING SYSTEM .....	3.13
COOLING SYSTEM PRESSURE TEST.....	3.13
PRESSURE CAP TEST .....	3.13
RADIATOR REMOVAL / INSTALLATION.....	3.14
THERMOSTAT REPLACEMENT .....	3.15
COOLING SYSTEM ASSEMBLY VIEW .....	3.17
COOLING SYSTEM BLEEDING PROCEDURE .....	3.18
WATER PUMP REMOVAL.....	3.19
WATER PUMP INSTALLATION.....	3.19
WATER PUMP SERVICE.....	3.21
ENGINE SERVICE.....	3.24
ACCESSIBLE ENGINE COMPONENTS .....	3.24
TOP-END SERVICE (ENGINE IN CHASSIS) .....	3.24
ENGINE REMOVAL .....	3.24
ENGINE INSTALLATION .....	3.28
ENGINE MOUNTING AND TORQUE VALUES.....	3.31
ENGINE BREAK-IN PERIOD .....	3.32
ENGINE LUBRICATION SPECIFICATIONS.....	3.32
ENGINE DISASSEMBLY / INSPECTION - TOP END .....	3.33
VALVE COVER REMOVAL .....	3.33
CAMSHAFT REMOVAL .....	3.33
CAMSHAFT SPROCKET INSPECTION .....	3.34
CAMSHAFT / CAMSHAFT BORE INSPECTION .....	3.34
CYLINDER HEAD REMOVAL .....	3.36
CYLINDER HEAD WARP INSPECTION .....	3.37
CYLINDER HEAD DISASSEMBLY .....	3.37
VALVE INSPECTION.....	3.38
COMBUSTION CHAMBER CLEANING.....	3.39
VALVE SEALING TEST .....	3.39

# ENGINE

---

VALVE SEAT RECONDITIONING .....	3.40
ENGINE DISASSEMBLY / INSPECTION - LOWER END .....	3.43
STATOR COVER REMOVAL / INSPECTION .....	3.43
WATER PUMP HOUSING REMOVAL .....	3.44
FLYWHEEL REMOVAL .....	3.44
STARTER ONE-WAY CLUTCH DISASSEMBLY .....	3.45
CRANKCASE DISASSEMBLY / INSPECTION .....	3.46
BALANCE SHAFT REMOVAL / INSPECTION .....	3.49
CRANKSHAFT REMOVAL / INSPECTION .....	3.50
CRANKCASE INSPECTION .....	3.52
CYLINDER INSPECTION .....	3.53
CYLINDER / PISTON REMOVAL .....	3.54
PISTON DISASSEMBLY / INSPECTION .....	3.55
PISTON RING REMOVAL .....	3.56
PISTON RING TO GROOVE CLEARANCE INSPECTION .....	3.57
PISTON RING INSTALLED GAP .....	3.57
PISTON-TO-CYLINDER CLEARANCE .....	3.57
CONNECTING ROD INSPECTION .....	3.58
ENGINE ASSEMBLY - LOWER END .....	3.60
BEARING SELECTION IDENTIFICATION LETTERS AND NUMBERS .....	3.60
CONNECTING ROD BEARING SELECTION .....	3.61
CRANKSHAFT MAIN BEARING SELECTION .....	3.61
UPPER CRANKCASE PREPARATION .....	3.61
PISTON RING INSTALLATION .....	3.62
PISTON / CONNECTING ROD ASSEMBLY .....	3.63
CYLINDER / PISTON INSTALLATION .....	3.64
CRANKSHAFT INSTALLATION .....	3.65
BALANCE SHAFT INSTALLATION .....	3.67
LOWER CRANKCASE PREPARATION .....	3.67
CRANKCASE ASSEMBLY .....	3.68
STARTER ONE-WAY CLUTCH ASSEMBLY .....	3.72
FLYWHEEL INSTALLATION .....	3.73
STATOR COVER INSTALLATION .....	3.73
ENGINE ASSEMBLY - TOP END .....	3.74
CYLINDER HEAD ASSEMBLY .....	3.74
CYLINDER HEAD INSTALLATION .....	3.75
CAMSHAFT INSTALLATION / TIMING .....	3.76
CAMSHAFT TIMING - QUICK REFERENCE .....	3.80
VALVE CLEARANCE ADJUSTMENT .....	3.81
INTAKE VALVE LASH - TAPPET SELECTION MATRIX .....	3.83
EXHAUST VALVE LASH - TAPPET SELECTION MATRIX .....	3.84
VALVE COVER INSTALLATION .....	3.85
TROUBLESHOOTING .....	3.86
ENGINE .....	3.86
COOLING SYSTEM .....	3.87

## GENERAL INFORMATION

### Special Tools

TOOL DESCRIPTION	PART NUMBER
Bench Mount Engine Stand Adapter	PW-47053
Clutch Center Distance Tool	PU-50658
Cylinder Holding & Camshaft Timing Plate	PU-50563
Engine Stand (2" Bore)	PU-50624
Engine Stand Adapter (Mounts To The Engine)	PU-50562
Engine Stand Sleeve Adapter (Use With 2" Bore Stand)	PU-50625
Engine Stand Sleeve Adapter (Use With 2.375" Bore Stand)	PW-47054
Flywheel Puller	PA-49316
Mity Vac™ Pressure Test Tool	2870975
Oil Filter Wrench	PU-50105
Oil Pressure Gauge	PV-43531
Oil Pressure Gauge Adapter	PU-50565
Piston Ring Compressor Pliers	PV-43570-1
Valve Spring Compressor	PV-1253 or PV-4019 (Quick Release)
Valve Spring Compressor Adapter	PV-43513-A
Water Pump Mechanical Seal Installer	PU-50564

**Bosch Automotive Service Solutions:** 1-800-345-2233  
or <http://polaris.service-solutions.com/>

### Engine Lubrication Specifications

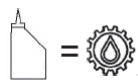

**Oil Capacity \***  
Approx. 2.5 Quarts (2.4 L)

**Oil Filter Wrench**  
PU-50105 or 2.5" (64 mm)

**Oil Filter**  
PN 2540086

**Oil Type**  
PS-4 PSynthetic Engine oil  
(PN 2876244) (Quart)  
(-35° F to 100° F)

PS-4 Extreme Duty  
Synthetic Engine Oil  
(PN 2878920) (Quart)  
(0° F to 120° F)

**Oil Pressure Minimum Specification  
(using Polaris engine oil at operating temperature)**  
10 PSI @ 1200 RPM  
40 PSI @ 7000 RPM

**\*Additional oil may be required after complete engine disassembly. Check level after filling and add oil as needed.**



# ENGINE

## Oil Pressure Test

1. Attach the Oil Pressure Gauge Adapter (PU-50565) to the Oil Pressure Gauge (PV-43531).

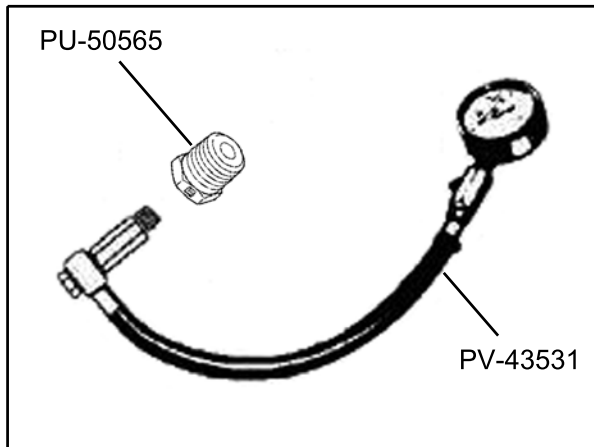

**Oil Pressure Gauge Adapter: PU-50565**  
**Oil Pressure Gauge: PV-43531**

2. Remove the seats, engine service panel, and divider panel heat shield.
3. Clean the area around the main oil gallery plug (A), located in the upper crankcase on the MAG side of the engine.
4. Remove the crankcase gallery plug (Item 1) and insert the oil pressure adapter.

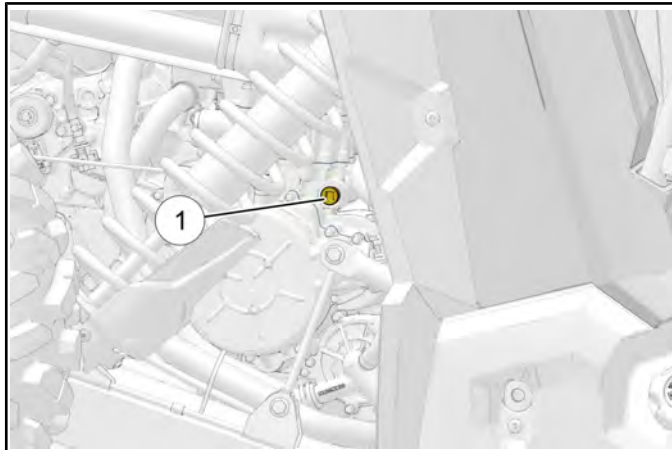

5. Start engine and allow it to reach operating temperature, monitoring gauge indication.

**NOTE: Test results are based on the use of the recommended engine oil (Polaris PS-4 or PS-4 Extreme Duty) at operating temperature, and may vary considerably if any other oil is used or if engine is not up to temperature.**

**Oil Pressure Specification (Engine Hot):**  
**Minimum @ 1200 RPM: 10 PSI**  
**Minimum @ 7000 RPM: 40 PSI**

6. Upon assembly, torque the crankcase gallery plug to specification.



**Crankcase Oil Gallery Plug:**  
**11 ft-lbs (15 Nm)**

Engine Oil Flow Chart

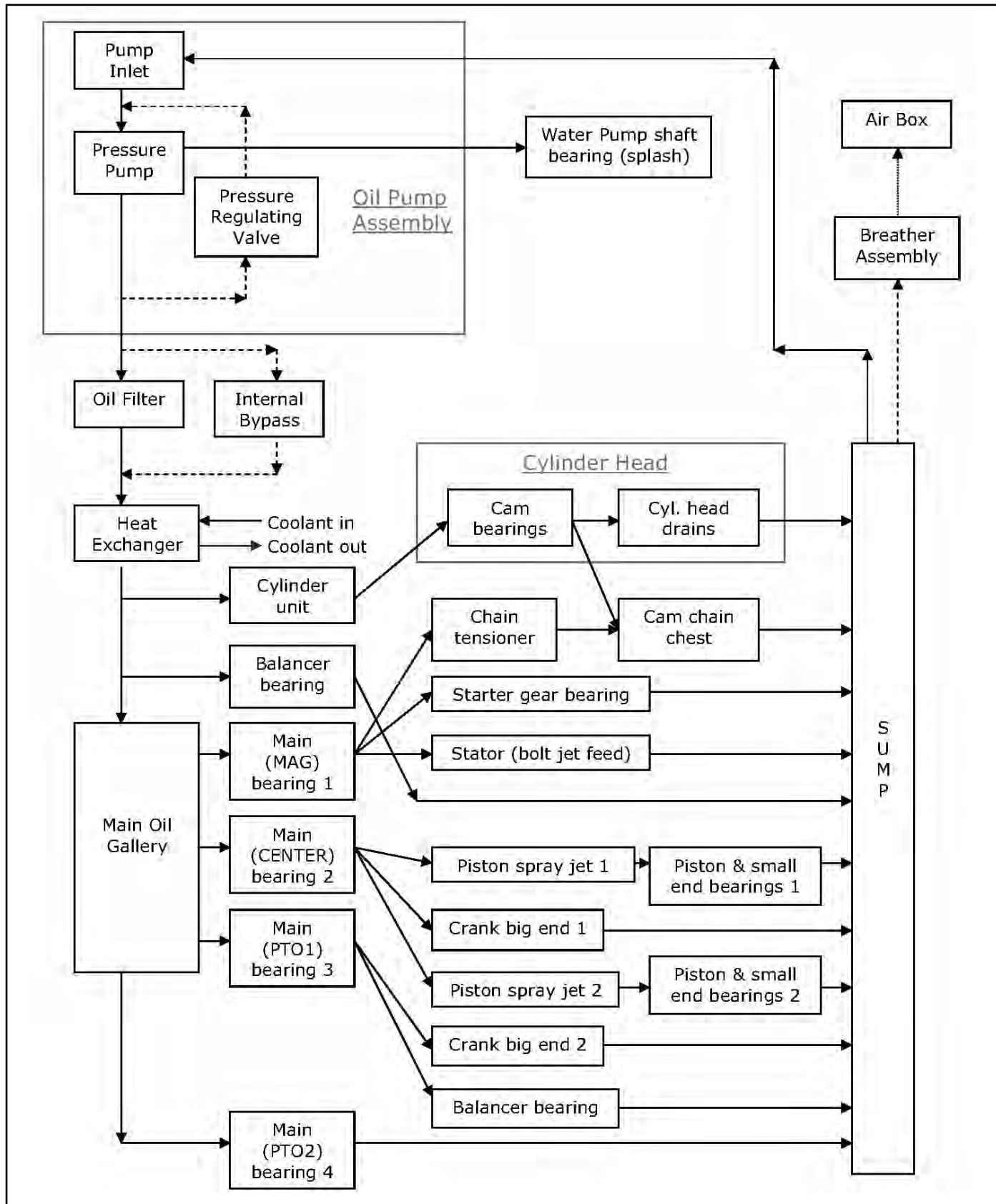

3

# ENGINE

## ENGINE SERVICE SPECIFICATIONS

### Engine Specifications

CAMSHAFT / CYLINDER HEAD / CYLINDER			
ITEM		STANDARD	SERVICE LIMIT
Camshaft	Cam Lobe Height - Intake	1.5390 - 1.5429" (39.09 - 39.19 mm)	1.5370" (39.04 mm)
	Cam Lobe Height - Exhaust	1.5142 - 1.5181" (38.46 - 38.56 mm)	1.5122" (38.41 mm)
	Camshaft Journal O.D. - All	0.9036 - 0.9055" (22.954 - 22.999 mm)	0.9033" (22.944 mm)
	Camshaft Carrier Bore I.D. - All	0.9055 - 0.9063" (23.000 - 23.021 mm)	0.9072" (23.044 mm)
	Camshaft Oil Clearance	0.0000 - 0.0026" (0.001 - 0.067 mm)	0.0039" (0.1 mm)
	Camshaft End Play	0.0040 - 0.0100" (0.101 - 0.254 mm)	0.0157" (0.4 mm)
Cylinder	Cylinder - Surface Warp Limit (cylinder head surface)	-	0.002" (0.05 mm)
	Cylinder Bore - Standard	3.6614 ± 0.0003" (93 mm ± 0.008 mm)	-
	Cylinder Out of Round Limit	-	0.001" (0.025 mm)
	Cylinder Taper Limit	-	0.001" (0.025 mm)
	Cylinder to Piston Clearance	0.0009 - 0.0019" (0.025 - 0.050 mm)	-
Cylinder Head	Cylinder Head - Surface Warp Limit	-	0.0039" (0.1 mm)
	Cylinder Head - Standard Height	4.717 ± 0.0019" (119.82 ± 0.05 mm)	-
Valve	Valve Lash (Cold) - Intake	0.006 ± 0.002" (0.15 ± 0.5 mm)	-
	Valve Lash (Cold) - Exhaust	0.008 ± 0.002" (0.20 ± 0.5 mm)	-
	Valve Stem Diameter - Intake	0.2155 - 0.2161" (5.475 - 5.490 mm)	-
	Valve Stem Diameter - Exhaust	0.2147 - 0.2153" (5.455 - 5.470 mm)	-
	Valve Stem Oil Clearance - Intake	0.0003 - 0.0015" (0.010 - 0.040 mm)	-
	Valve Stem Oil Clearance - Exhaust	0.0011 - 0.0023" (0.030 - 0.060 mm)	-
	Valve Stem Overall Length - Intake	3.7704" (95.77 mm)	-
	Valve Stem Overall Length - Exhaust	3.8023" (96.58 mm)	-
Valve Guide	Valve Guide Inner Diameter	0.2165 - 0.2171" (5.500 - 5.515 mm)	-
Valve Seat	Valve Seat - Contacting Width - Intake	0.0393 ± 0.0039" (1.0 ± 0.10 mm)	0.0551" (1.4 mm)
	Valve Seat - Contacting Width - Exhaust	0.0590 ± 0.0039" (1.5 ± 0.10 mm)	0.0748" (1.9 mm)
	Valve Seat Angles	30.0° ± 1.5° 45.0° ± 0.5° 60.0° ± 1.5°	-

PISTON / RINGS / CONNECTING ROD / CRANKSHAFT / BALANCE SHAFT				
ITEM		STANDARD		SERVICE LIMIT
Piston	Standard O.D. - Measured 90° to pin, 0.39 in. (10 mm) up from piston skirt		3.6597 ± 0.0003" (92.959 ± 0.008 mm)	-
	Piston Pin Bore I.D. (Standard)		0.7877 - 0.7881" (20.009 - 20.018 mm)	0.7893" (20.05 mm)
	Piston Pin O.D.		0.7873 - 0.7875" (20.000 - 20.005 mm)	0.7866" (19.98 mm)
Piston Ring	Installed Gap	Top Ring	0.010 - 0.014" (0.25 - 0.35 mm)	0.0196" (0.5 mm)
		Second Ring	0.015 - 0.025" (0.37 - 0.63 mm)	0.028" (0.70 mm)
		Oil Control Rails	0.008 - 0.028" (0.20 - 0.70 mm)	0.0354" (0.9 mm)
	Ring to Groove Clearance	Top Ring	0.0007 - 0.0023" (0.020 - 0.060 mm)	0.0047" (0.12 mm)
		Second Ring		
Connecting Rod	Connecting Rod Small End I.D.		0.7879 - 0.7885" (20.015 - 20.030 mm)	0.7897" (20.06 mm)
	1 - Marking	Conn. Rod Big End Bore I.D.	1.7318 - 1.7321" (43.989 - 43.996 mm)	-
	2 - Marking	Conn. Rod Big End Bore I.D.	1.7321 - 1.7323" (43.996 - 44.003 mm)	-
	3 - Marking	Conn. Rod Big End Bore I.D.	1.7323 - 1.7326" (44.003 - 44.010 mm)	-
Crankshaft	B - Marking	Main Journal O.D.	1.6140 - 1.6143" (40.996 - 41.004 mm)	1.6129" (40.970 mm)
	G - Marking	Main Journal O.D.	1.6137 - 1.6140" (40.988 - 40.995 mm)	1.6129" (40.970 mm)
	Y - Marking	Main Journal O.D.	1.6134 - 1.6137" (40.980 - 40.987 mm)	1.6129" (40.970 mm)
	B - Marking	Rod Journal O.D.	1.6118 - 1.6122" (40.942 - 40.950 mm)	1.6104" (40.906 mm)
	G - Marking	Rod Journal O.D.	1.6115 - 1.6118" (40.934 - 40.941 mm)	1.6104" (40.906 mm)
	Y - Marking	Rod Journal O.D.	1.6112 - 1.6115" (40.926 - 40.933 mm)	1.6104" (40.906 mm)
	Crankshaft Runout Limit (PTO and MAG)		-	Less than 0.001" (0.025 mm)
Balance Shaft	Bearing Journal O.D. (Standard)		1.4939 - 1.4946" (37.946 - 37.962 mm)	1.4921" (37.900 mm)

3

# ENGINE

## ENGINE DETAIL - TORQUE VALUES / SEQUENCES / ASSEMBLY NOTES

### Main Engine Components - Torque Specification and Sequence

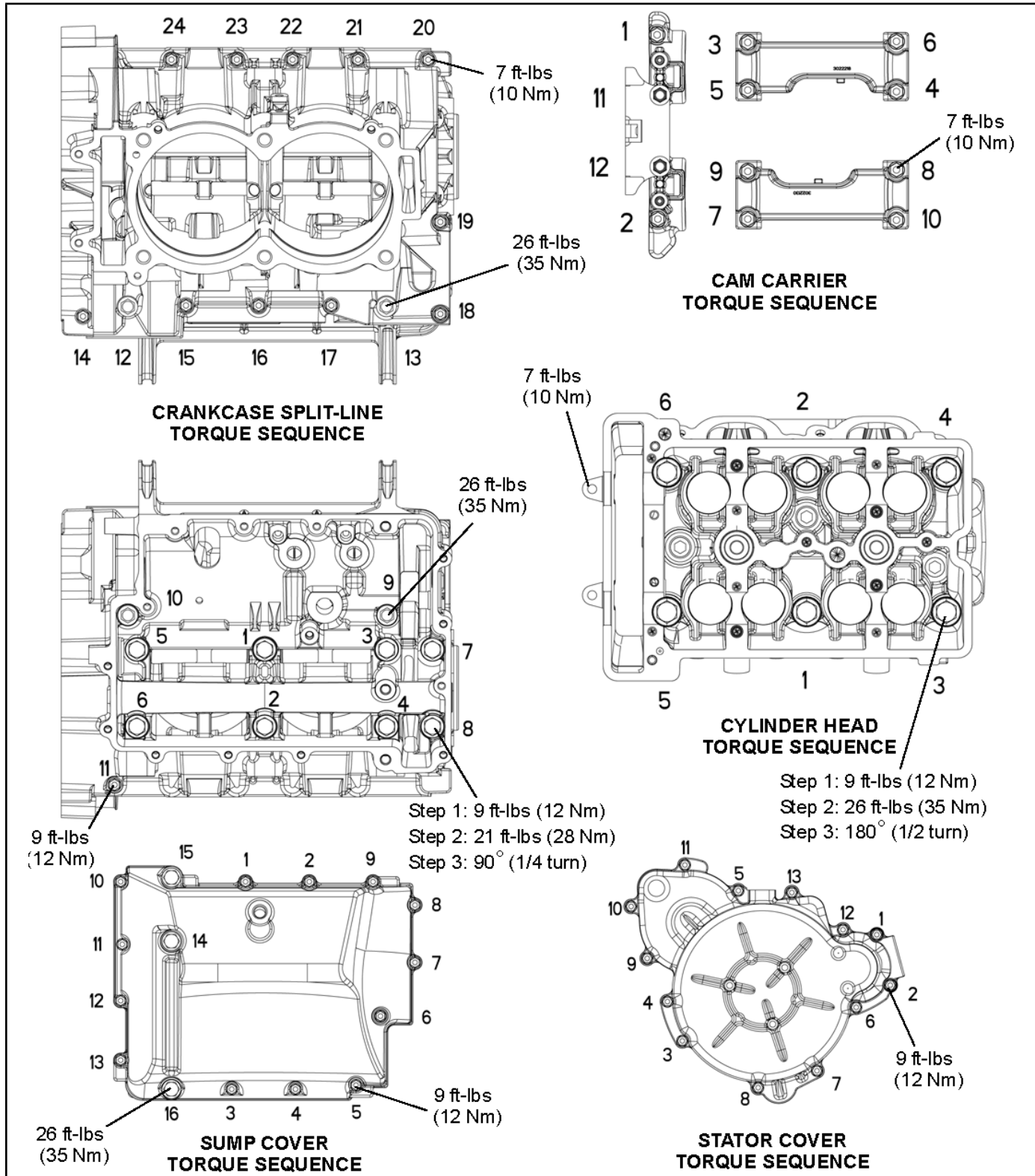

## Balance Shaft / Connecting Rods / Crankcase / Crankshaft / Pistons

FASTENER TORQUE TABLE	
A	6.5 ± 1.0 N·m
B	8.0 ± 1.0 N·m
C	10.0 ± 1.0 N·m
D	12.0 ± 1.0 N·m
E	16.0 ± 1.5 N·m
F	22.5 ± 2.5 N·m
G	24.0 ± 2.5 N·m
H	28.0 ± 3.0 N·m
K	35.0 ± 3.5 N·m
L	40.0 ± 4.0 N·m
M	2.8 ± 0.3 N·m
N	1.0 ± 0.5 N·m

AA	1) TORQUE BOTH FASTENERS TO 12 Nm 2) TORQUE BOTH FASTENERS TO 18 Nm 3) COMPLETE 105° FOR EACH FASTENER
BB	1) TORQUE ALL FASTENERS TO 12 Nm IN SEQUENCE SPECIFIED 2) TORQUE ALL FASTENERS TO 28 Nm IN SEQUENCE SPECIFIED 3) COMPLETE 90° IN SEQUENCE SPECIFIED
CC	1) TORQUE ALL FASTENERS TO 12 Nm IN SEQUENCE SPECIFIED 2) TORQUE ALL FASTENERS TO 35 Nm IN SEQUENCE SPECIFIED 3) COMPLETE 180° IN SEQUENCE SPECIFIED
DD	19.0 ± 1.0 Nm
EE	180.0 ± 12.0 Nm
GG	60.0 ± 6.0 Nm

**NOTES**

- 2) APPLY ENGINE OIL OR WHITE LITHIUM GREASE TO INTERNAL BEARING SURFACE.
- 3) INSTALL CIRCLIP WITH OPEN END WITHIN INDICATED ZONES. CHECK PREVIOUSLY INSTALLED CIRCLIP TO ENSURE THAT THE OPEN END IS THE SAME.
- 4) CLEAN WITH 10% RED OR ALCOHOL. SEAL MATING SURFACES WITH SEALANT. SEE SEALANT PATH VIEW. SEALANT MUST NOT BLOCK OIL PASSAGES.
- 5) SELECT PROPER BEARINGS PER CHART.
- 6) TORQUE IN SEQUENCE PER CRANKCASE SPLIT-LINE VIEW.
- 7) INSURE THAT OIL DEFLECTOR IS PROPERLY POSITIONED IN UPPER CRANKCASE.

# ENGINE

## Cylinder / Oil Cooler / Oil Filter / Oil Pump / Oil Sump / Water Pump

**OIL COOLER TORQUE SEQUENCE**

3 1  
2 4

**FASTENER TORQUE TABLE**

A	6.5±1.0 N-m
B	8.0±1.0 N-m
C	10.0±1.0 N-m
D	12.0±1.0 N-m
E	16.0±1.5 N-m
F	22.5±2.5 N-m
G	24.0±2.5 N-m
H	28.0±3.0 N-m
I	35.0±3.5 N-m
J	40.0±4.0 N-m
M	2.8±0.3 N-m
N	1.0±0.5 N-m
AA	1) TORQUE BOTH FASTENERS TO 12 Nm 2) TORQUE BOTH FASTENERS TO 18 Nm 3) COMPLETE 105° FOR EACH FASTENER
BB	1) TORQUE ALL FASTENERS TO 12 Nm IN SEQUENCE SPECIFIED 2) TORQUE ALL FASTENERS TO 28 Nm IN SEQUENCE SPECIFIED 3) COMPLETE 90° IN SEQUENCE SPECIFIED
CC	1) TORQUE ALL FASTENERS TO 12 Nm IN SEQUENCE SPECIFIED 2) TORQUE ALL FASTENERS TO 35 Nm IN SEQUENCE SPECIFIED 3) COMPLETE 180° IN SEQUENCE SPECIFIED
DD	19.0±1.0 Nm
EE	180.0±12.0 Nm
GG	60.0±5.0 Nm

**NOTES:**

- LUBRICATE SEAL WITH ENGINE OIL PRIOR TO FILTER INSTALLATION.
- ENSURE TAB IS VISIBLE TO VERIFY ASSEMBLY.
- TORQUE IN SEQUENCE SHOWN IN OIL SUMP COVER VIEW.
- ENSURE O-RING SEALS ARE SEATED IN C'BORES BEFORE ASSEMBLY.
- APPLY ENGINE OIL TO CYLINDER BORES PRIOR TO ASSEMBLY.
- CLEAN WITH NON-RESIDUE DEGREASER OR ALCOHOL, SEAL MATING SURFACES WITH SEALANT. SEE SEALANT PATH VIEW.
- APPLY LUBE TO ORING PRIOR TO PUMP ASSEMBLY TO CRANKCASE.
- TORQUE IN SEQUENCE SHOWN IN OIL COOLER VIEW.

## Camshafts / Cylinder Head / Flywheel / Idler Gears / Stator Cover

**FASTENER TORQUE TABLE**

A	6.5 ± 1.0 N·m
B	8.0 ± 1.0 N·m
C	10.0 ± 1.0 N·m
D	12.0 ± 1.0 N·m
E	16.0 ± 1.5 N·m
F	22.5 ± 2.5 N·m
G	24.0 ± 2.5 N·m
H	28.0 ± 3.0 N·m
I	35.0 ± 3.5 N·m
J	40.0 ± 4.0 N·m
M	2.8 ± 0.3 N·m
N	1.0 ± 0.5 N·m

AA	1) TORQUE BOTH FASTENERS TO 12 Nm 2) TORQUE BOTH FASTENERS TO 18 Nm 3) COMPLETE 105° FOR EACH FASTENER
BB	1) TORQUE ALL FASTENERS TO 17 Nm IN SEQUENCE SPECIFIED 2) TORQUE ALL FASTENERS TO 28 Nm IN SEQUENCE SPECIFIED 3) COMPLETE 90° IN SEQUENCE SPECIFIED
CC	1) TORQUE ALL FASTENERS TO 12 Nm IN SEQUENCE SPECIFIED 2) TORQUE ALL FASTENERS TO 35 Nm IN SEQUENCE SPECIFIED 3) COMPLETE 180° IN SEQUENCE SPECIFIED
DD	19.0 ± 1.0 Nm
EE	180.0 ± 12.0 Nm
GG	60.0 ± 6.0 Nm

**NOTES:**

- 1 INSURE TAB IS VISIBLE TO VERIFY ASSEMBLY.
- 2 TORQUE IN SEQUENCE SHOWN IN STATOR COVER VIEW.
- 3 CLEAN THE MOUNTING SURFACE ON BOTH THE CRANKSHAFT AND FLYWHEEL WITH ALCOHOL. SURFACES SHOULD BE FREE FROM OIL OR GREASE.
- 4 TORQUE IN SEQUENCE SHOWN FOR CAM CARRIERS.
- 5 TORQUE LIMITING GEAR SHAFT TO BE COATED WITH WHITE LITHIUM GREASE (SHAFT TO BUSHINGS ON TIG).
- 6 LUBRICATE WITH ENGINE OIL OR GREASE PRIOR TO ASSEMBLY.
- 7 APPLY GREASE TO O-RING.
- 8 CRANK POSITION SENSOR TO BE ROUTED BEHIND BYPASS BRACKET.

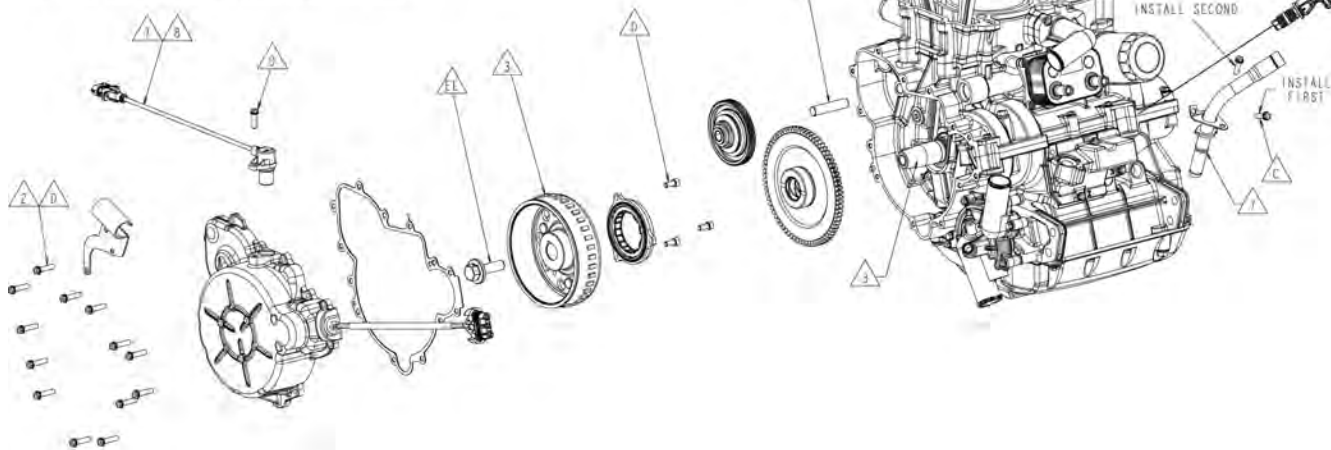



# ENGINE

## Spark Plugs / Starter / Thermostat Housing / Throttle Body / Valve Cover

FASTENER TORQUE TABLE

A	6.5±1.0 N-m
B	8.0±1.0 N-m
C	10.0±1.0 N-m
D	12.0±1.0 N-m
E	16.0±1.5 N-m
F	22.5±2.5 N-m
G	24.0±2.5 N-m
H	28.0±3.0 N-m
K	35.0±3.5 N-m
L	40.0±4.0 N-m
M	2.8±0.3 N-m
N	1.0±0.5 N-m

AA	1) TORQUE BOTH FASTENERS TO 12 Nm IN SEQUENCE SPECIFIED 2) TORQUE BOTH FASTENERS TO 18 Nm IN SEQUENCE SPECIFIED 3) COMPLETE 105° FOR EACH FASTENER
BB	1) TORQUE ALL FASTENERS TO 12 Nm IN SEQUENCE SPECIFIED 2) TORQUE ALL FASTENERS TO 28 Nm IN SEQUENCE SPECIFIED 3) COMPLETE 90° IN SEQUENCE SPECIFIED
CC	1) TORQUE ALL FASTENERS TO 12 Nm IN SEQUENCE SPECIFIED 2) TORQUE ALL FASTENERS TO 35 Nm IN SEQUENCE SPECIFIED 3) COMPLETE 180° IN SEQUENCE SPECIFIED
DD	19.0±1.0 Nm
EE	180.0±12.0 Nm
GG	60.0±6.0 Nm

NOTES:

- 1) APPLY SEALANT TO ALL FOUR INSIDE CORNERS OF VALVE COVER GASKET.
- 2) APPLY LUBE TO SHOULDER OF VALVE COVER FASTENERS PRIOR TO ASSEMBLY.
- 3) INSERT TOP SCREW FIRST AND HAND TIGHTEN; THEN INSERT LOWER SCREW AND TORQUE; THEN TORQUE TOP SCREW.
- 4) APPLY ANTI-SEIZE PASTE TO SPARK PLUG THREADS.
- 5) APPLY STARTER O-RING GREASE TO STARTER O-RING PRIOR TO ASSEMBLY.
- 6) APPLY ENGINE OIL TO FILL CAP THREAD AREA PRIOR TO ASSEMBLY.

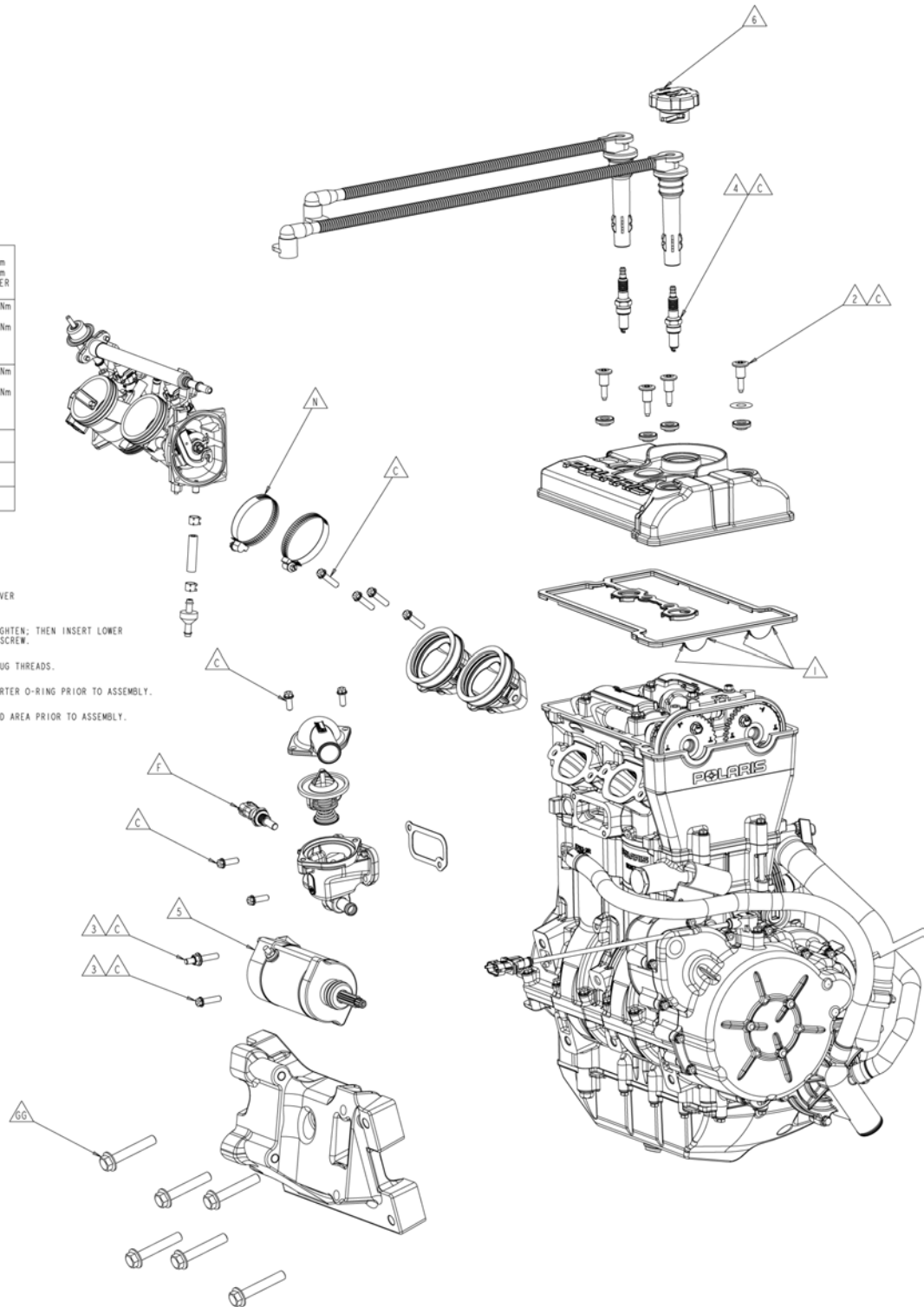

## ENGINE COOLING SYSTEM

### Cooling System Specifications

CONDITION	COOLANT TEMP °F (°C)
Room Temperature	68° F (20° C)
Thermostat Open	180° F (82° C)
Fan Off	192° F (89° C)
Fan On	198° F (92° C)
Thermostat Full Open	203° F (95° C)
Engine Temperature Overheat Indicator	233° F (112° C)
Engine Protection Ignition Misfire	236° F (113° C)
Engine Protection Shutdown	257° F (125° C)

ITEM	SPECIFICATION
Cooling System Capacity	4.9 qts. (4.6 L)
Pressure Cap Relief	13 PSI

**Polaris Premium Antifreeze**  
**2871534 - Quart**  
**2871323 - Gallon**

### Recommended Coolant

Use only high quality antifreeze/coolant mixed with distilled water in a 50/50 or 60/40 ratio, depending on freeze protection required in your area.

**CAUTION:** Using tap water in the cooling system will lead to a buildup of deposits which may restrict coolant flow and reduce heat dissipation, resulting in possible engine damage. Polaris Premium 60/40 Antifreeze/Coolant is recommended for use in all cooling systems and comes pre-mixed, ready to use.

### Cooling System Pressure Test

1. Remove the hood from the front cab.

#### **WARNING**

Never remove pressure cap when engine is warm or hot. The cooling system is under pressure and serious burns may result.  
 Allow the engine to cool before servicing.

2. Remove pressure cap and pressure test the cooling system using a commercially available pressure tester.

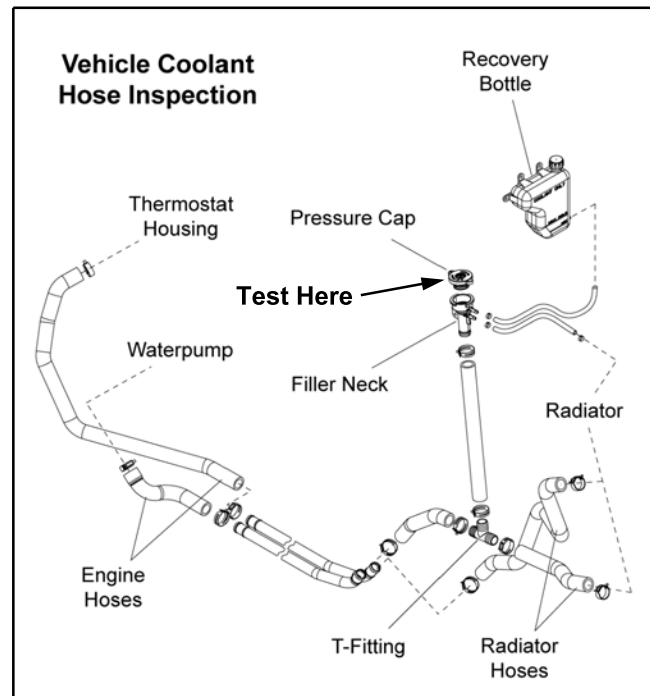

3. The system must maintain 10 psi for five minutes or longer. If pressure loss is evident within five minutes, check the filler neck, radiator, hoses, clamps and water pump weep hole for leakage.

### Pressure Cap Test

1. Remove the hood from the front cab.

#### **WARNING**

Never remove pressure cap when engine is warm or hot. The cooling system is under pressure and serious burns may result. Allow the engine to cool before servicing.

# ENGINE

2. Remove pressure cap (Item 1) and test using a pressure cap tester (commercially available).

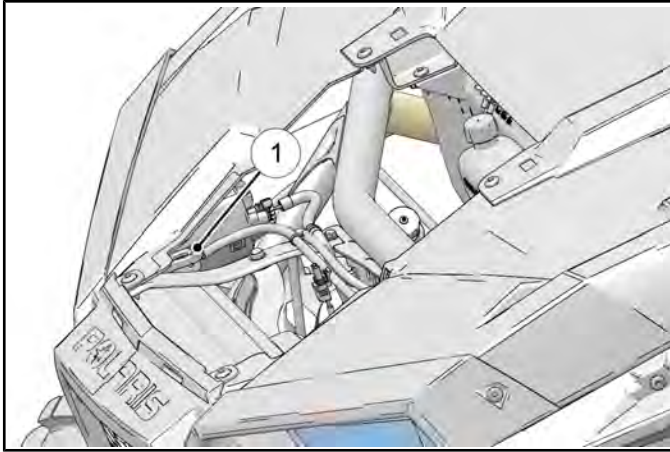

3. Drain radiator by removing lower radiator hose (Item 1). Be sure to catch and dispose of coolant properly.

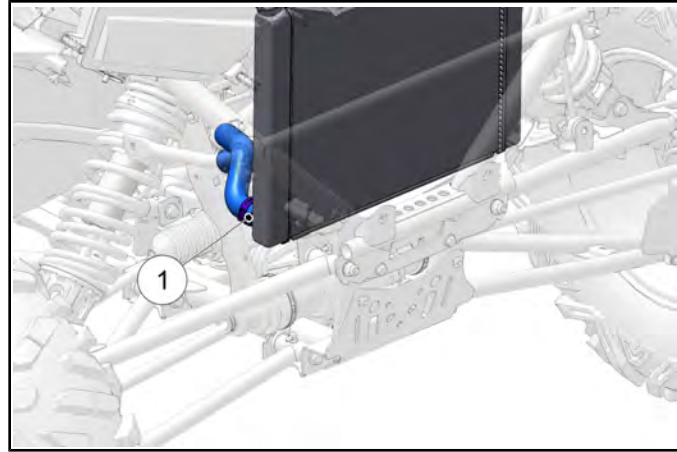

3. The pressure cap relief pressure is 13 psi. Replace cap if it does not meet this specification.

## Radiator Removal / Installation

1. Remove the hood and front bumper (See Hood and Front Body Work, page 5.20 and Front Bumper, page 5.19).
2. Remove the four fasteners that secure the front bumper support to the main frame.

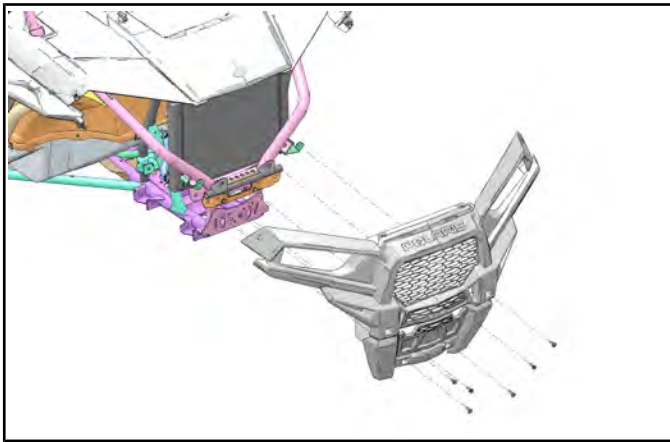

### **WARNING**

The cooling system is under pressure and serious burns may result.  
Allow the engine to cool before servicing.

4. Disconnect cooling fan electrical connector.
5. Remove the upper radiator hose from the radiator.
6. Remove the four upper radiator support fasteners (Item 2) and disconnect the small radiator bypass hose (Item 3).

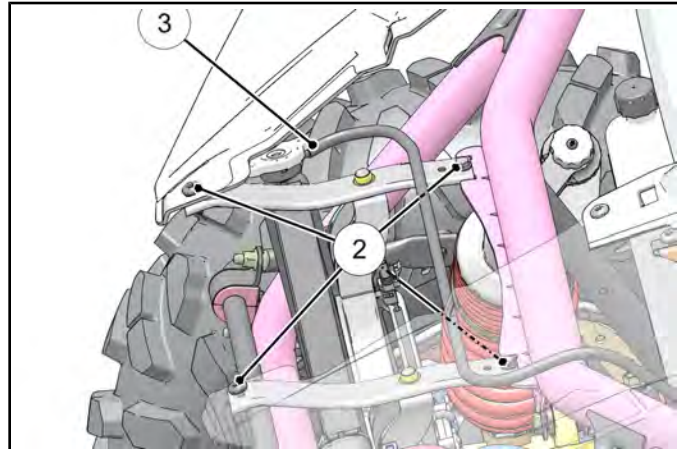

7. Lift radiator up to disengage it from its lower mounting points. Tilt top of radiator outward and remove the radiator from the vehicle.
8. Separate the fan motor assembly from the radiator. Inspect fan blades for damage.

- Reverse this procedure for installation. Be sure to properly fill and bleed cooling system as outlined in this chapter.

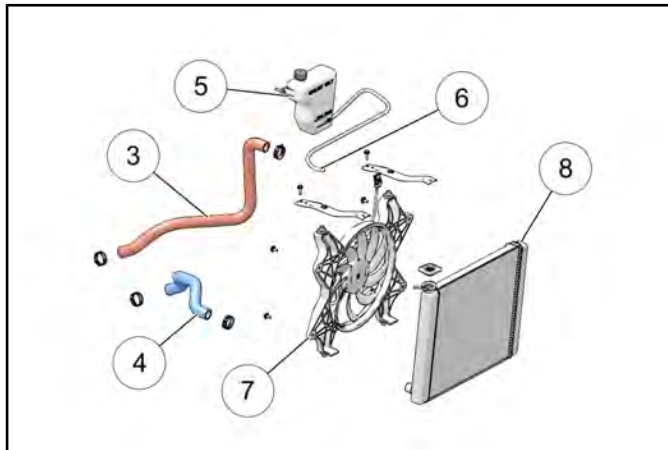

3. Upper Radiator Hose	6. To Radiator Fitting
4. Lower Radiator Hose	7. Fan Motor Assembly
5. Recovery Bottle	8. Radiator

## Thermostat Replacement

- Remove the hood from the front cab.

### WARNING

The cooling system is under pressure and serious burns may result.  
Allow the engine to cool before servicing.

- Remove the pressure cap to relieve any system pressure (see "Pressure Cap Test").
- Drain coolant to a level below the thermostat housing.

- Remove upper coolant hose from thermostat housing (Item 1).

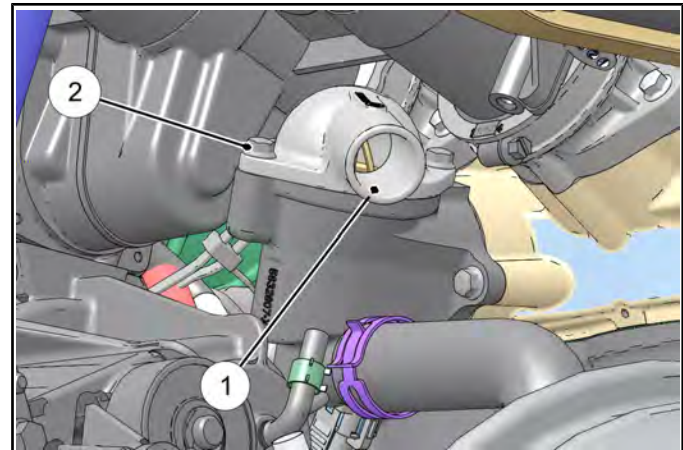

- Remove the rear bolt (Item 2) retaining the thermostat cover.
- Remove the cargo box access panel.
- Using an 8 mm swivel socket and long extension, remove the front bolt (Item 3) retaining the thermostat cover.

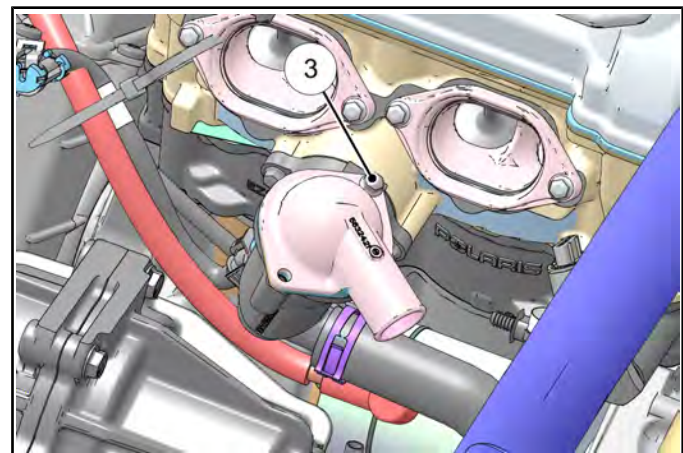

- Lift the cover from the housing and remove the thermostat.

**NOTE:** Thermostat has a pop-off relief to allow the bypass system to operate until thermostat opens.

## ENGINE

---

9. Install a new thermostat with the bleed hole (Item 4) positioned closest to the engine.

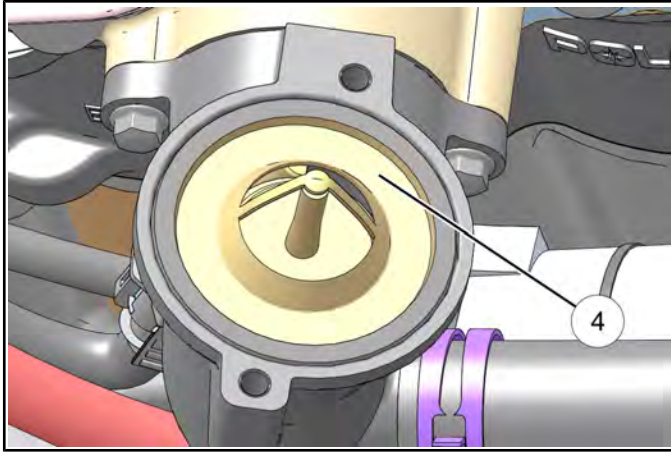

**NOTE:** Image shown above is with engine removed for clarity.

10. Reverse this procedure for installation. Torque thermostat cover bolts to specification.



**Thermostat Cover Bolts:  
7 ft-lb (10 Nm)**

11. Be sure to properly fill and bleed cooling system as outlined in this chapter.

## Cooling System Assembly View

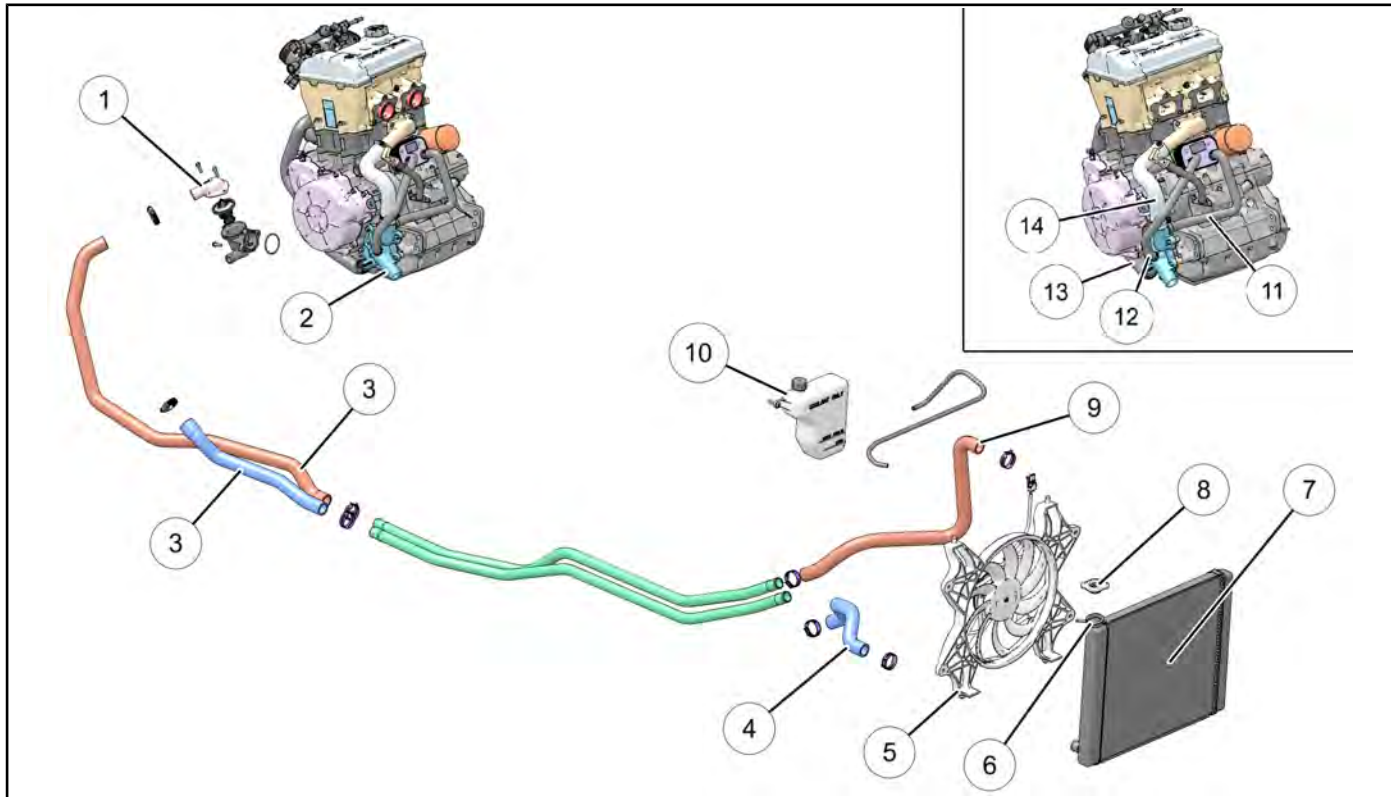

3

1. Thermostat housing	6. Filler Neck	11. Oil Cooler Inlet Hose
2. Water Pump	7. Radiator	12. Oil Cooler Outlet Hose
3. Engine Hoses	8. Pressure Cap	13. Bypass Hose
4. Lower Radiator Hose	9. Upper Radiator Hose	14. Water Pump Outlet Hose
5. Fan Assembly	10. Recovery Bottle	

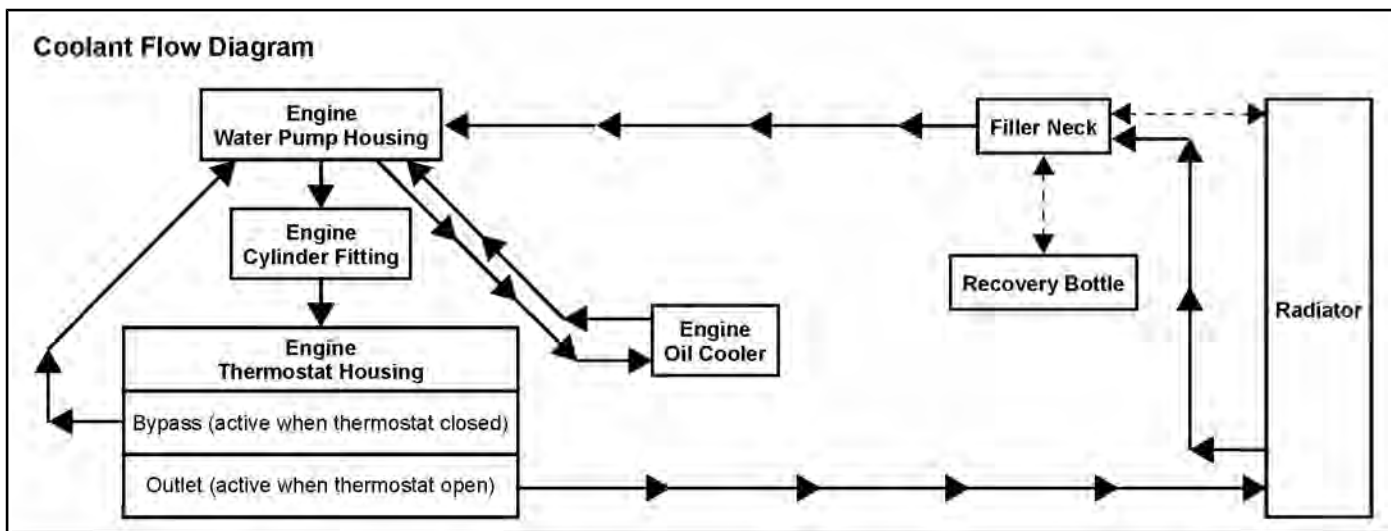

# ENGINE

## Cooling System Bleeding Procedure

### WARNING

Always wear safety glasses and proper shop clothing when performing the procedures in this manual. Failing to do so may lead to possible injury or death.

### CAUTION

Use caution when performing these procedures. Coolant may be hot and may cause severe injury or burns.

**NOTE:** If the coolant level is **LOW** in the radiator, or if there are leaks in the system, the coolant system will not draw coolant from the reservoir tank.

1. Allow engine and cooling system to cool down.

### CAUTION

Be sure the engine has cooled and no pressure is built up in the cooling system before removing the pressure cap. The coolant may be hot and could cause severe injury or burns.

2. Remove the hood.
3. Remove the recovery bottle cap (Item 1) and fill the bottle to the MAX line.

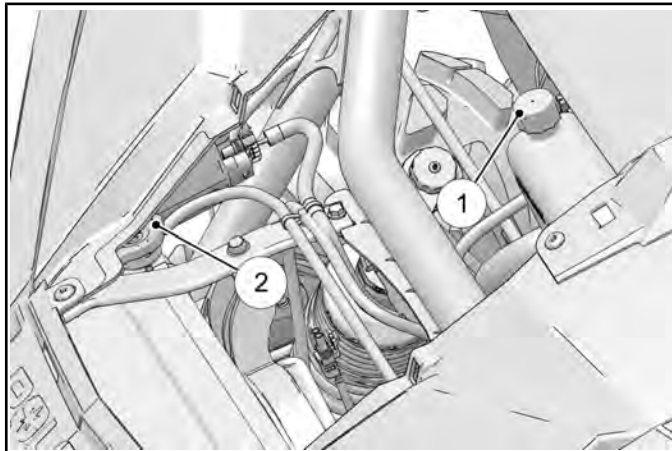

4. Remove the pressure cap (Item 2) and add the necessary amount of Polaris Premium Antifreeze to the radiator filler neck.
5. Remove the seats, engine service panel and divider panel heat shield to access the coolant bleed screw.

6. Open the bleed screw (Item 3) to allow any trapped air to escape. Close the bleed screw once a steady stream of coolant begins to drain out.

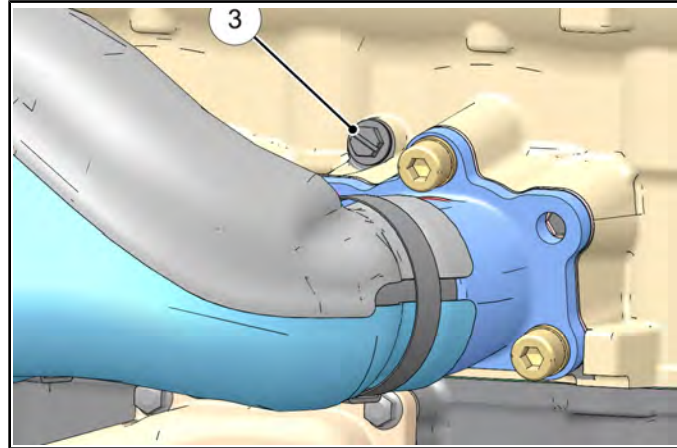

7. Tighten the bleed screw to specification, top off coolant and properly install the pressure cap.



Coolant Bleed Screw:  
**89 in-lb (10 Nm)**

8. Start the engine and allow it to idle until the coolant fan has cycled two times.
9. Allow engine and cooling system to completely cool down (see CAUTION).
10. Remove the pressure cap. Add the necessary amount of Polaris Premium Antifreeze to the radiator filler neck.
11. Open the bleed screw to allow any trapped air to escape. Close the bleed screw once a steady stream of coolant begins to drain out.
12. Tighten the bleed screw to specification, top off coolant and properly install the pressure cap.



Coolant Bleed Screw:  
**89 in-lb (10 Nm)**

13. Fill the recovery bottle to the MAX line.
14. Reinstall the hood.
15. Reinstall the seats and engine service panel.

## Water Pump Removal

1. Allow engine and cooling system to cool down.

### CAUTION

Be sure the engine has cooled and no pressure is built up in the cooling system before removing the pressure cap. The coolant may be hot and could cause severe injury or burns.

2. Remove driver's seat.
3. Disconnect the (-) negative battery cable.
4. Remove all debris and thoroughly clean water pump area and RH side of engine block.
5. Remove the hood.
6. Remove the pressure cap from the filler neck.
7. Drain cooling system as outlined in this chapter.
8. Elevate the rear of the vehicle off the ground using a suitable ATV lift and remove the right rear wheel.
9. Remove the right rear shock lower mounting bolt. Discard the nut. Swing and support right rear shock rearward to gain access to water pump area.
10. Remove the five coolant hoses that are attached to the water pump. Note location and routing for installation. Be sure to catch and dispose of coolant properly.
11. Remove the three bolts (Item 1 & 2) retaining water pump to engine block. Note different bolt lengths for installation.

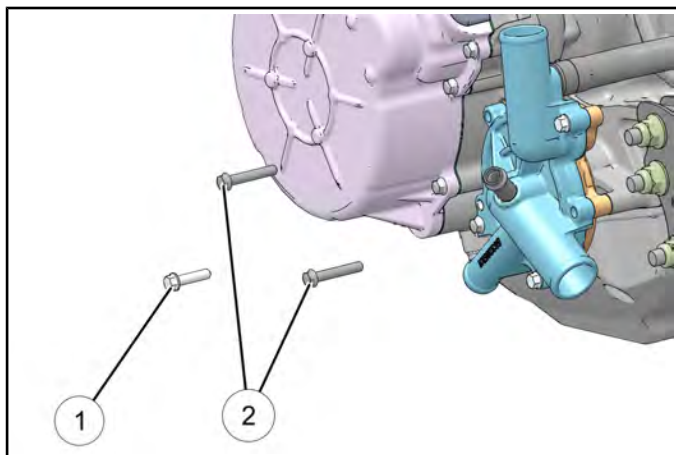

12. Remove water pump from engine by gently twisting and rocking the water pump housing while pulling outward.
13. Maneuver water pump downward and remove it through the access hole in the skid plate.
14. Plug the water pump drive access hole in the engine block with a clean shop towel.

## Water Pump Installation

1. Replace the two sealing O-rings on the water pump housing.

**NOTE:** Do not reuse the water pump O-rings. Always use NEW O-rings each time the water pump is removed.

2. Lubricate new O-rings (Item 1) with fresh engine oil.

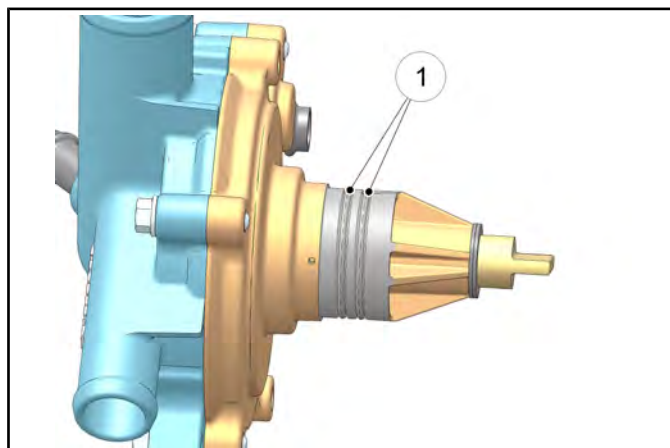

3. Remove the shop towel from the water pump drive access hole in the engine block.
4. Clean the O-ring sealing surface (Item 2) in the engine block using a clean shop towel.

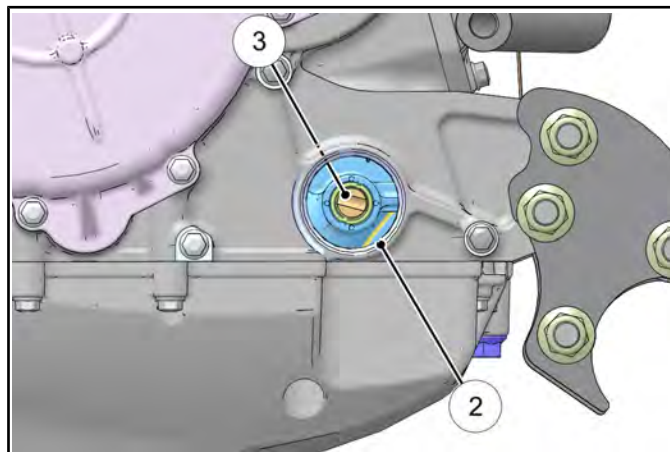

5. Use a shop light to illuminate the water pump drive access hole in engine crankcase and note orientation of the water pump drive slot (Item 3).



# ENGINE

- Rotate water pump drive tab (Item 4) so it matches the angle of the drive slot in the engine.

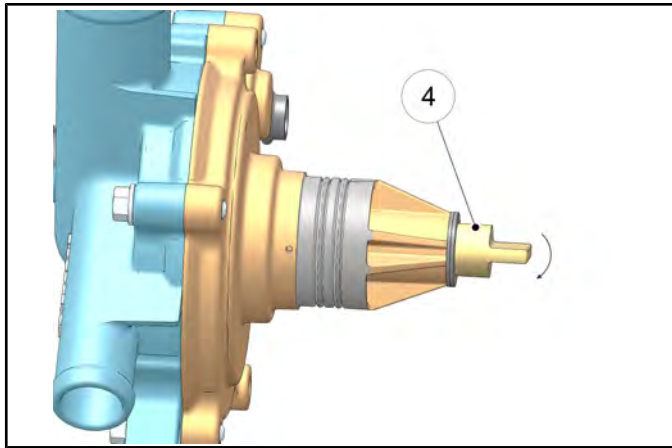

## CAUTION

The water pump drive tab and slot must be aligned properly during installation. Severe engine or water pump damage will occur if the tab and slot are not in alignment during water pump installation.

- Maneuver water pump up through the access hole in the skid plate on the RH side of the vehicle.
- Slide water pump into engine crankcase.
- Be sure water pump is fully seated and the drive tab and slot are properly engaged.

- Install the three water pump mounting bolts (Item 5 & 6) and torque to specification.

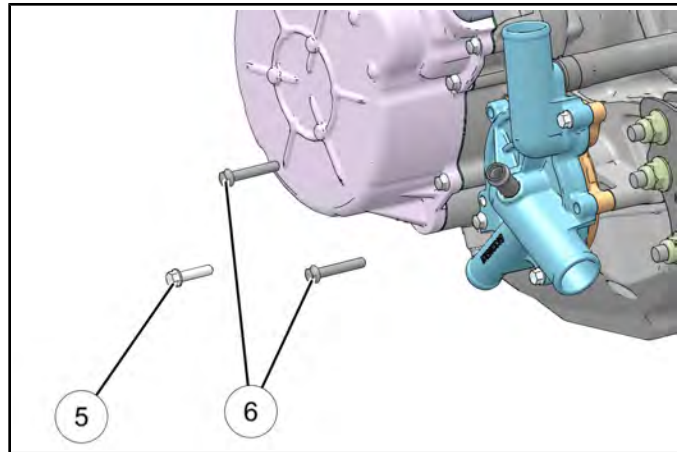

**NOTE:** Install different bolt lengths as shown.



**Water Pump Mounting Bolts:  
7 ft-lb (10 Nm)  
(Apply Loctite® 204™ to bolt threads)**

- Install the four coolant hoses (Item 7–10) that attach to the water pump. Be sure orientation and routing are correct.

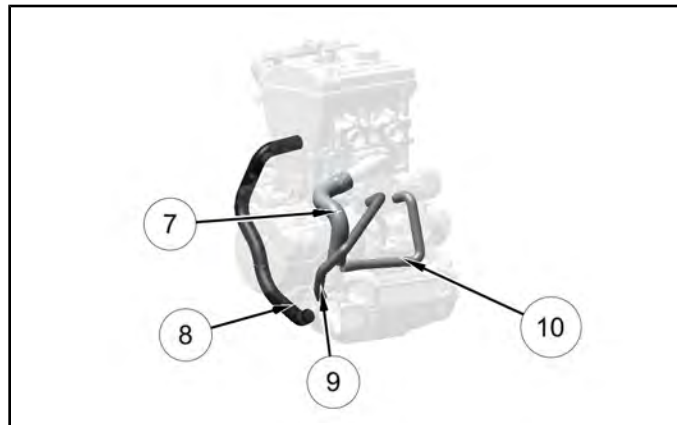

- Install the right rear lower shock bolt and new nut. Torque mounting bolt to specification.



**Rear Shock Mounting Bolt:  
70 ft-lbs (95 Nm)**

13. Install the right rear wheel. Torque wheel nuts to specification.

 = T
<b>Wheel Nuts: 120 ft-lbs (163 Nm)</b>

14. Connect the (-) negative battery cable.
15. Fill and bleed cooling system as outlined in this chapter.
16. Install the hood, engine service panel and seats.

## Water Pump Service

**NOTE:** The water pump cover gasket can be replaced while the water pump housing is still installed in the engine.

1. Remove water pump assembly as outlined in this chapter.
2. Remove the three bolts retaining water pump cover (Item 1) to water pump housing (Item 2). Discard cover gasket (Item 3).

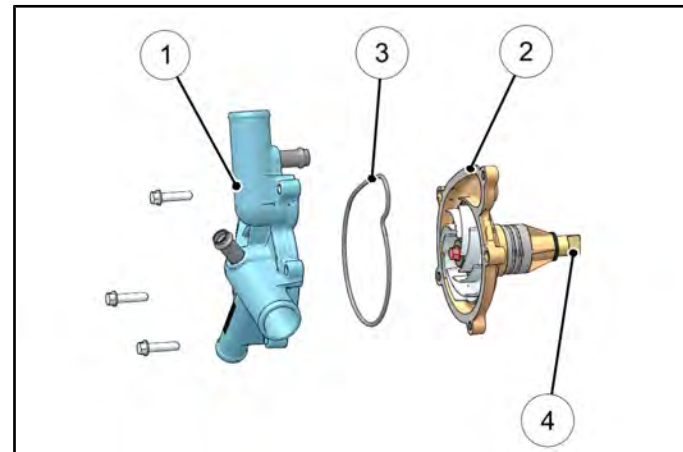

3. Place the water pump drive tab (Item 4) vertically into a soft jaw vice.
4. Remove the bolt and washer retaining the water pump impeller to the shaft. Inspect the impeller veins and water pump housing for damage. Replace if needed.

**NOTE:** The water pump impeller bolt (Item 5) is left hand thread (reverse thread).

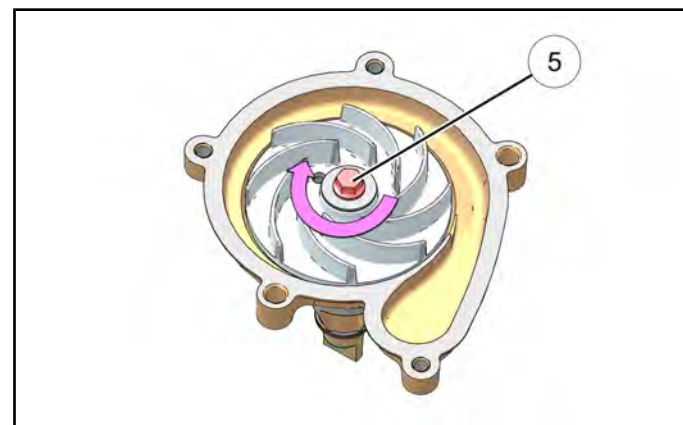

5. Remove impeller from water pump shaft.
6. Using an appropriate arbor press, properly support the water pump housing and press out the water pump shaft from the impeller side.

3

## ENGINE

7. Extract the mechanical seal and the oil seal from the water pump housing.

**NOTE: A 5/32" (4 mm) diameter punch (Item 6) will fit in the lubrication slot to aid in the removal of the oil seal. Be sure not to damage the water pump shaft bearing surface.**

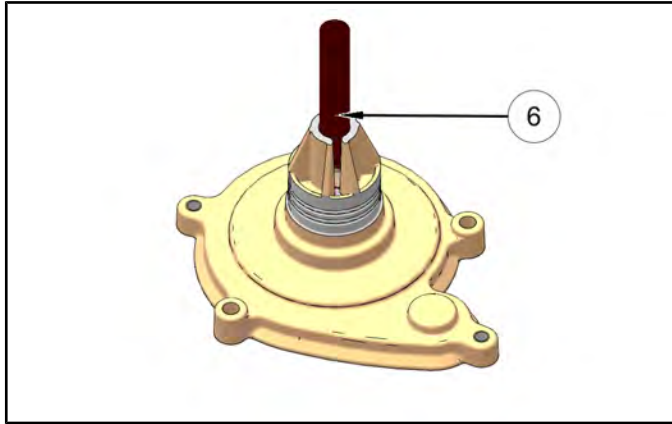

8. Inspect the water pump shaft bore for excessive wear or damage. Replace water pump housing assembly if necessary.
9. Clean and inspect water pump shaft for excessive wear or damage. Replace water pump housing assembly if necessary, as shaft can not be purchased separately.
10. Thoroughly clean mechanical seal and oil seal bores.
11. Install a NEW oil seal into the water pump housing until fully seated.
12. Fully install the water pump shaft and two washers into the housing.
13. Place water pump drive tab vertically into soft jaw vice as previously shown in this procedure.
14. Install a NEW mechanical seal into the water pump housing using special tool PU-50564. Press the new mechanical seal in until it is flush with the water pump housing.

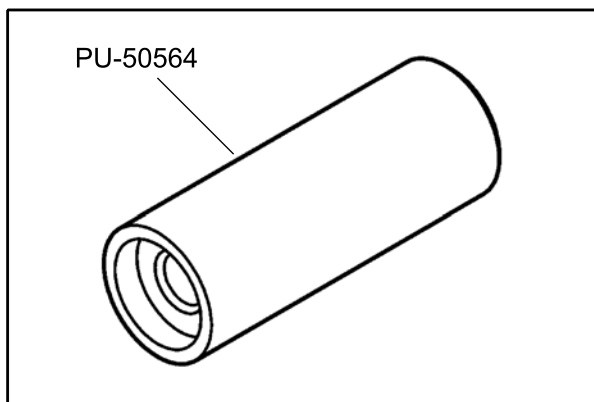

15. Rotate water pump shaft after seal installation to verify free movement.
16. Place impeller onto the water pump shaft.
17. Apply Loctite® 204™ to the threads of the impeller bolt. Install washer and impeller bolt and torque to specification.



Water Pump Impeller Bolt:  
**7 ft-lb (10 Nm)**  
**(Apply Loctite® 204™ to bolt threads)**

18. Clean cover (Item 1) and housing gasket surfaces (Item 2).
19. Install a new water pump cover gasket (Item 3).

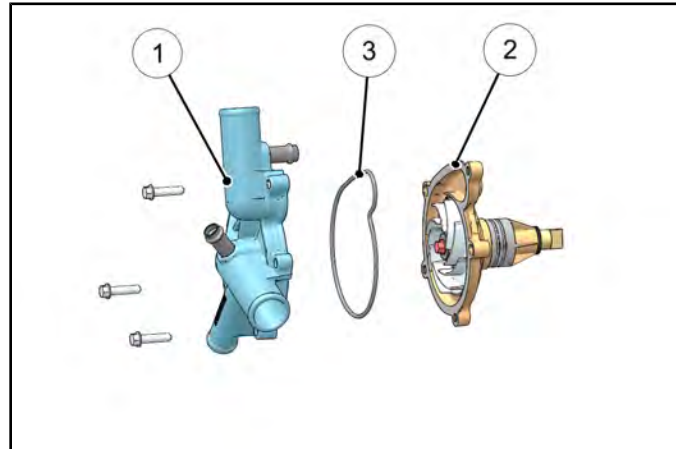

20. Install the water pump cover and three retaining bolts (Item 8). Torque bolts in sequence to specification.

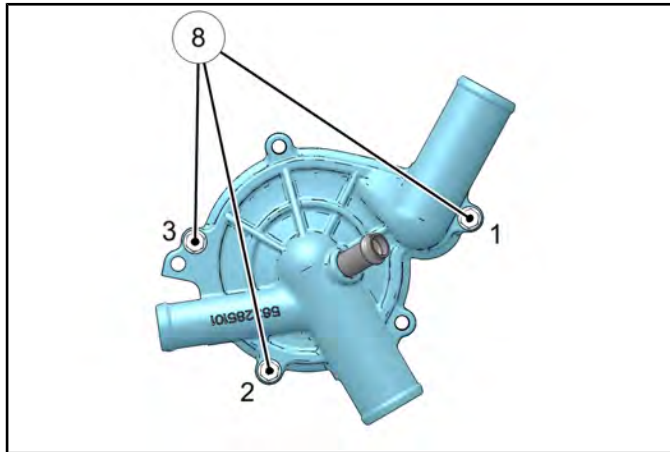

**Water Pump Cover Bolts:  
7 ft-lb (10 Nm)  
(Apply Loctite® 204™ to bolt threads)**

21. Install two new water pump (O-rings) and lubricate them with fresh engine oil.
22. Install water pump assembly into engine as shown in the "Water Pump Installation" procedure.

**3**

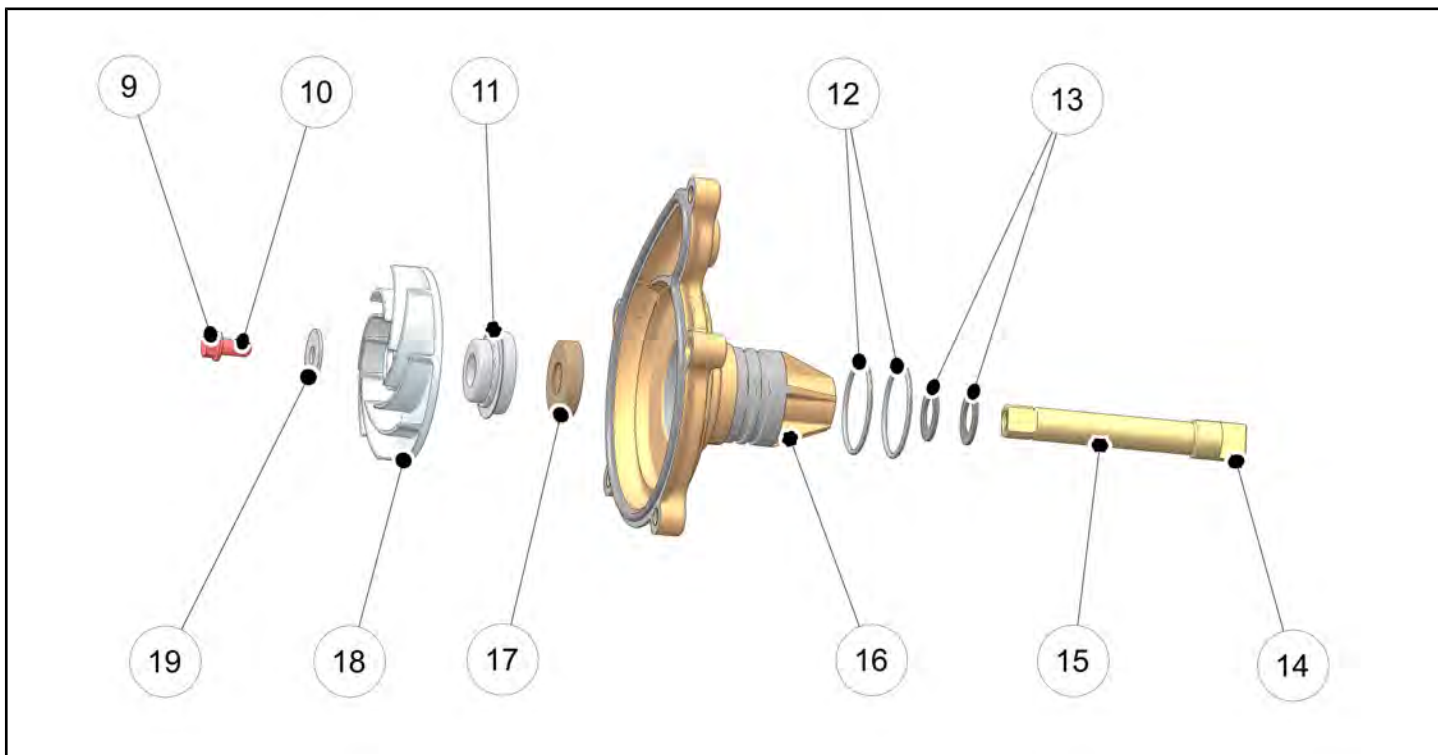

9. Bolt	13. Washers	17. Oil Seal
10. Loctite 204	14. Drive Tab	18. Impeller
11. Mechanical Seal	15. Water Pump Shaft	19. Washer
12. O-Rings	16. Water Pump Housing	

# ENGINE

---

## ENGINE SERVICE

### Accessible Engine Components

The following components can be serviced or removed with the engine installed:

- Camshaft(s)
- Camshaft Sprocket(s)
- Cylinder Head
- Flywheel
- Oil Cooler
- Starter Motor / Idler Gear Asm
- Stator (Alternator)
- Thermostat
- Valve Cover
- Water Pump

The following components require engine removal for service:

- Camshaft Timing Chain
- Connecting Rod(s)
- Counterbalance Shaft / Bearings
- Crankcase
- Crankshaft / Main Bearings
- Crankshaft Seal (PTO)
- Cylinder
- Oil Pump / Oil Pump Sprocket or Chain
- Piston / Rings

### Top-End Service (Engine in Chassis)

Some top-end engine components can be serviced while the engine is mounted in the chassis.

To service the top-end of the engine refer to Valve Clearance Inspection, page 2.19, which provides detailed steps to access the valve cover.

### Engine Removal

**NOTE:** Some engine repair procedures can be performed without removing the engine assembly from the vehicle. Refer to Accessible Engine Components, page 3.24 for further information.

The use of an overhead or portable engine hoist is the only recommended method for removing and installing the engine.

Have an assistant help guide the engine in and out of the vehicle while using an engine hoist to prevent personal injury or damage to vehicle components.

#### **WARNING**

Always wear safety glasses and proper shop clothing when performing the procedures in this Service Manual. Failing to do so may lead to possible injury.

1. If vehicle was recently operated, allow it to cool down before attempting to perform any work.
2. Thoroughly clean the engine and chassis.
3. Drain the engine oil and coolant prior to engine removal (See Coolant Drain / Fill, page 2.26).
4. Remove the seats.
5. Disconnect the (-) negative battery cable from the battery.
6. Remove the rear bumper and cargo box (see Chapter 5).
7. Remove the air box assembly.
8. Elevate the rear of the vehicle off the ground using a suitable lift and remove the left rear wheel.

#### **WARNING**

Use care when supporting vehicle so that it does not tip or fall.  
Serious injury may occur if vehicle tips or falls.

9. Remove lower mounting bolt (Item 1) from the left rear shock and discard the nut. Install a new nut upon assembly.

- Remove the outer clutch cover screws (Item 2) and remove the cover from the vehicle.

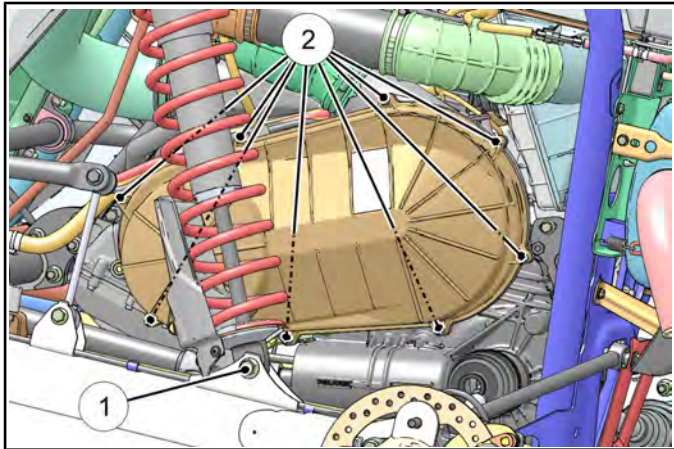

- Remove drive belt, drive clutch, driven clutch, inner clutch cover and clutch outlet duct (see Chapter 6).

## CAUTION

### Correct Drive Clutch Puller P/N 2872085

2872085 - Correct Drive Clutch Puller For RZR XP 900

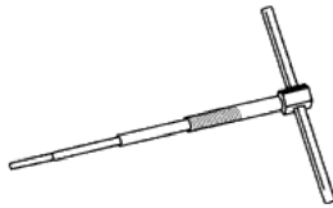

PA-48595 - Incorrect Drive Clutch Puller

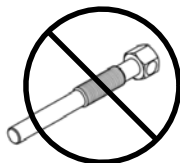

**NOTE:** Be sure to use the correct Drive Clutch Puller (PN 2872085) to prevent damage to crankshaft.

- Disconnect the TMAP sensor (Item 3), fuel injector harness leads (Item 4), CPS (Item 5), ECT sensor (Item 6), and ignition coil harness lead. Remove wire ties retaining harness to the fuel rail and rear cross member.

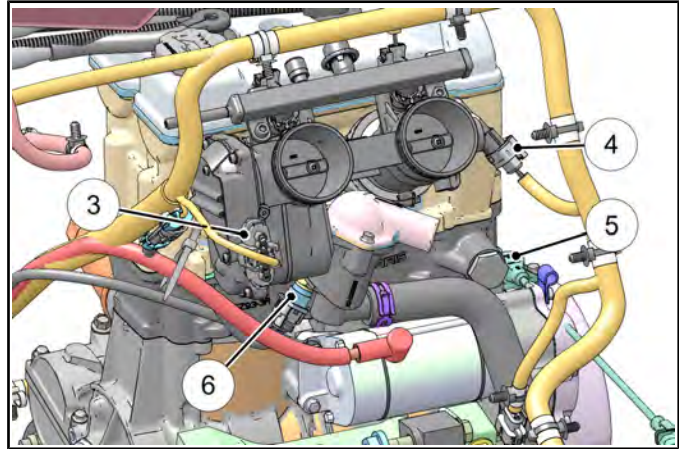

- Disconnect the stator harness.
- Remove (+) positive cable from the starter motor.
- Remove (-) negative cable from the starter mounting bolt.
- Disconnect fuel lines and remove throttle body assembly (See Fuel Line Removal / Installation, page 4.10 Fuel Line Removal / Installation, page 4.10 Throttle Body Removal, page 4.31). Make note of line routing for installation.
- Remove spark plug wires from the engine.

**NOTE:** The spark plug wires are marked with **MAG** and **PTO**. Note during installation procedure.

- Remove the breather hose (Item 7) from the crankcase.

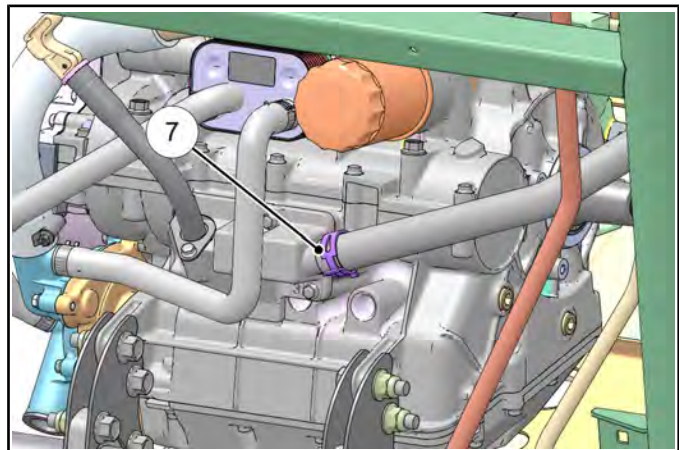

## ENGINE

19. Remove the six fasteners that attach the exhaust head pipe to the engine. Remove the two exhaust springs (Item 8) that attach the head pipe (Item 9) to the muffler. Remove exhaust head pipe towards the front of the vehicle. Discard exhaust gaskets (Item 10).

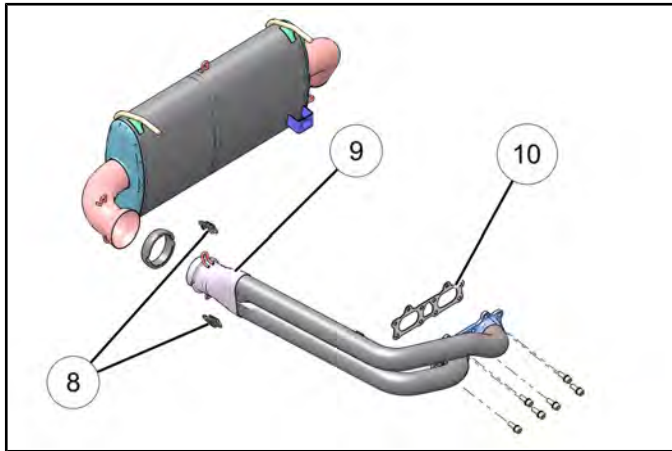

20. Remove the four fasteners retaining the box support (Item 11) and the two fasteners retaining the box support bracket (Item 12). Remove the push rivet that attaches the heat shield (Item 13) to the rear cross member.

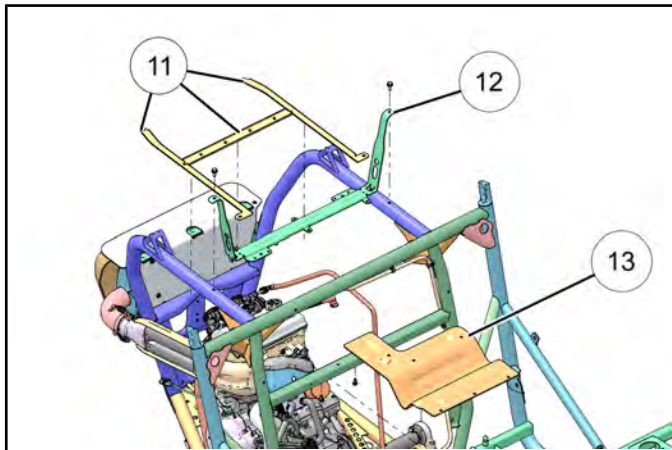

21. Place a suitable drain pan under the vehicle and remove the thermostat housing coolant hose (Item 14) and the water pump coolant hose (Item 15) from the engine. Dispose of engine coolant properly.

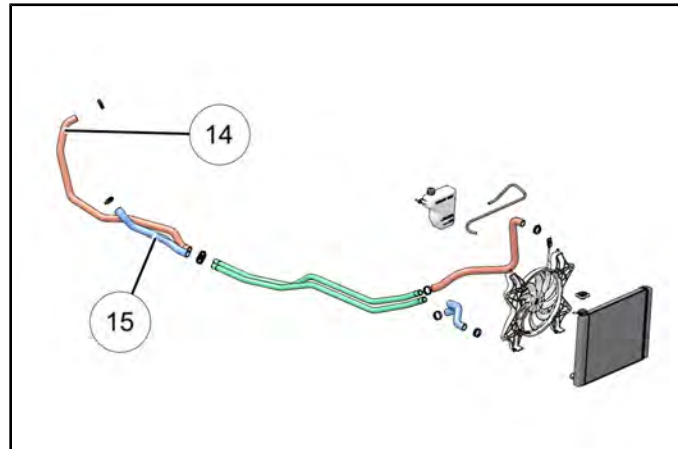

22. Use an overhead or portable engine hoist and suitable engine straps to secure engine in its current position.

23. Remove the four rear mounting bolts (Item 16) that attach the rear of the engine to the transmission.

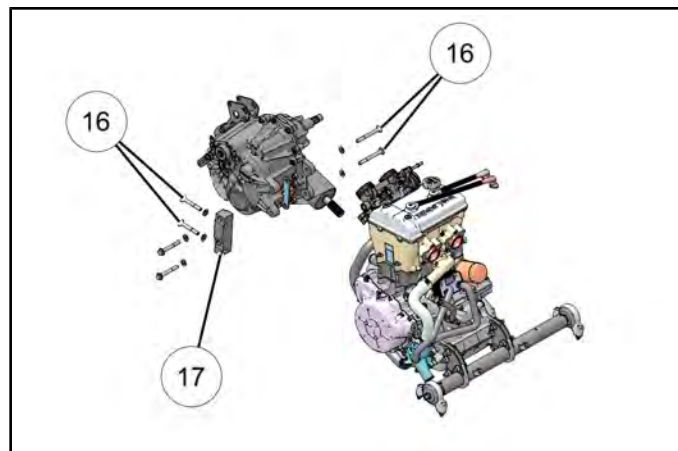

**NOTE:** It is *not necessary* to remove the bolts that retain the bracket (Item 17) to the transmission.

24. Remove the four front engine mounting bolts (Item 18) and nuts (Item 19).

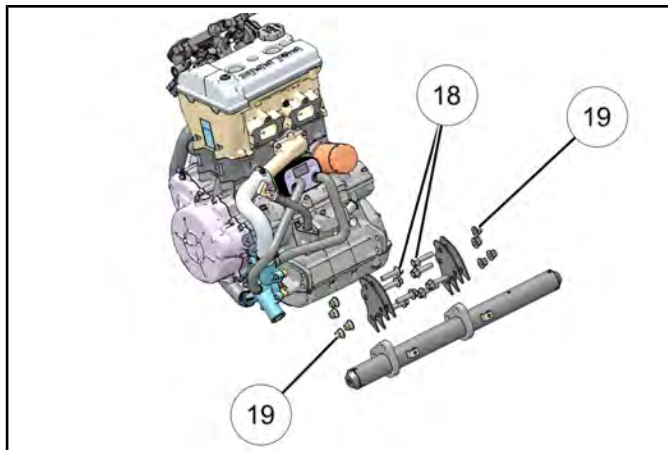

30. Place engine onto the engine stand (PU- 50624) for service.

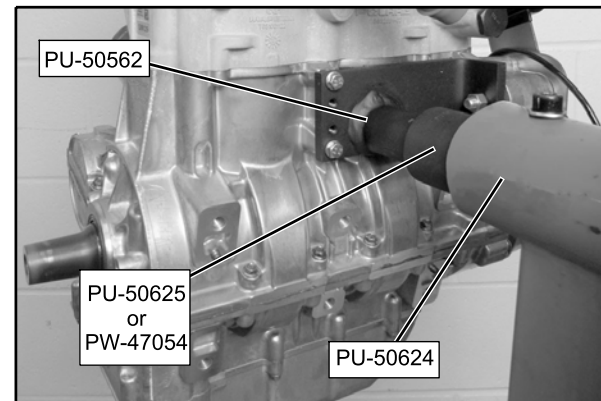

25. With the help of an assistant and the engine hoist, raise the engine vertically out of the vehicle frame.

**NOTE: Have an assistant help guide the engine in and out of the vehicle while using an engine hoist to prevent personal injury or damage to vehicle components.**

26. Remove the starter motor bolts (Item 20) and starter motor from the engine.

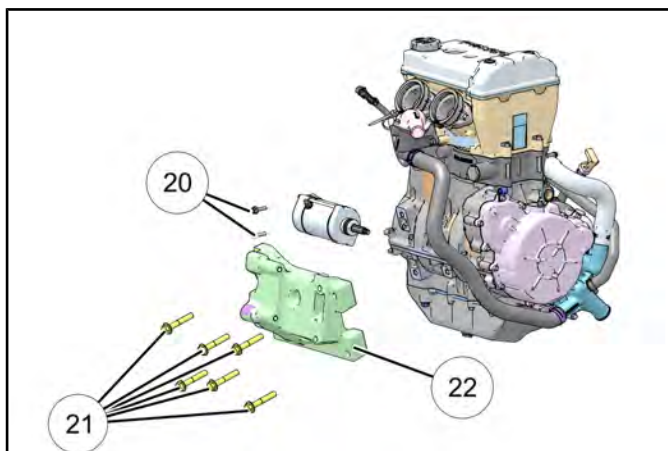

27. Remove the six transmission joint bracket bolts (Item 21) and transmission joint bracket (Item 22) from the engine.

28. Install the engine stand adapter (PU-50562) onto the engine where the starter motor was located.

29. Select the proper engine stand sleeve adapter and install it onto the engine stand adapter.

- Sleeve adapter for a 2" bore engine stand:
  - (PU-50625)
- Sleeve adapter for a 2.375" bore engine stand:
  - (PW-47054)



# ENGINE

## Engine Installation

Use the following procedure to reinstall the engine assembly.

1. Attach engine with suitable lifting straps to an overhead or portable engine hoist.
2. Remove the engine stand adapter plate and install the starter motor back onto engine. Torque starter motor bolts to specification.
3. Install transmission joint bracket onto engine and torque fasteners to specification in sequence.

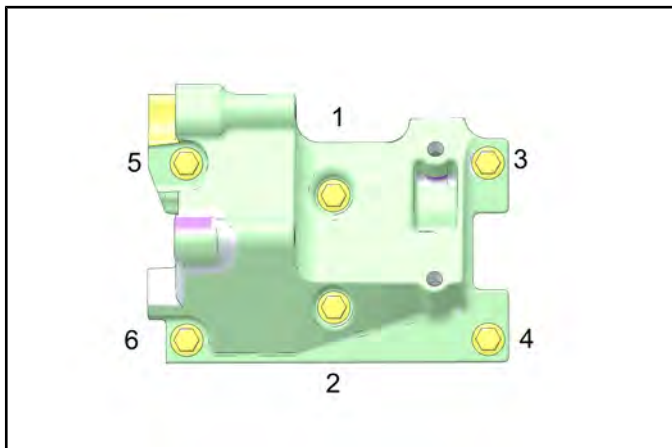
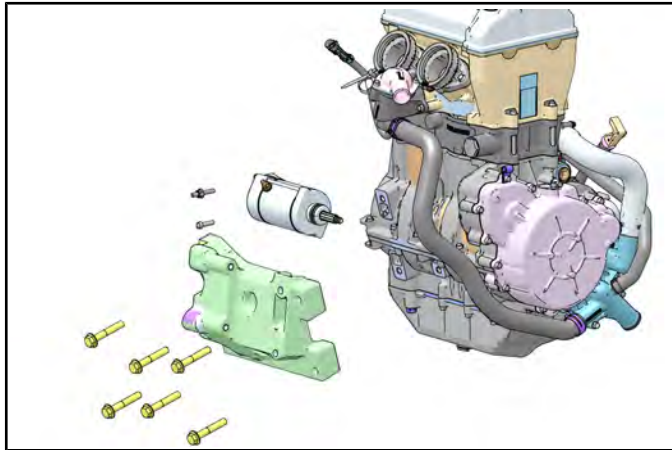

Starter Motor Bolts:  
**7 ft-lb (10 Nm)**

Trans Joint Bracket Bolts:  
**44 ft-lb (60 Nm)**

4. Use the overhead or portable engine hoist and suitable engine straps to lower the engine into the vehicle frame.

**NOTE: Have an assistant help guide the engine in and out of the vehicle while using an engine hoist to prevent personal injury or damage to vehicle components.**

5. Align both the front and rear engine mounting locations. Install and hand tighten the four front engine mounting nuts (Item 1) and bolts (Item 2).

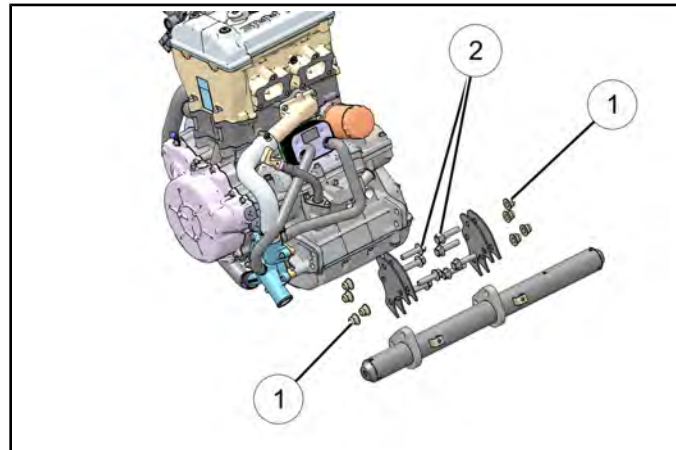

**NOTE: DO NOT torque fasteners at this time.**

6. Align transmission joint mounting holes with the transmission front mounting holes.

7. Install the Clutch Center Distance Tool (PU-50658) onto the crankshaft (Item 3) and transmission input shaft to properly position the clutch center distance. The pictures below show the tool (PU-50658) properly installed (Item 4).

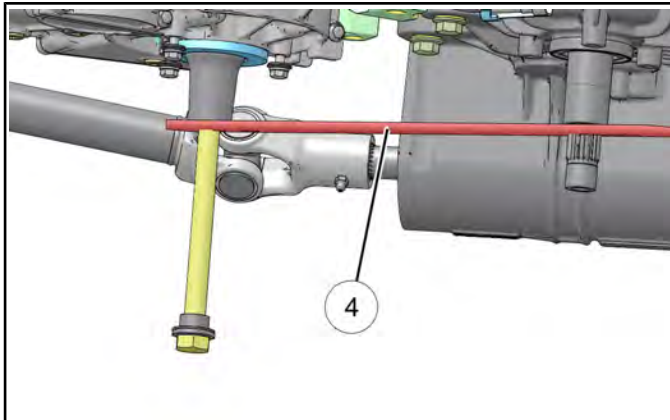
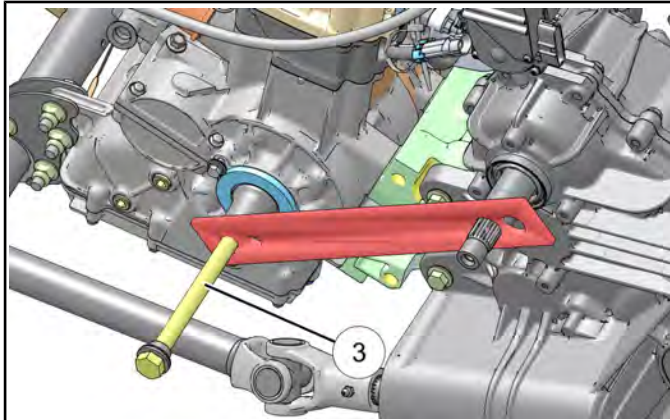

8. Loosen the two bolts (Item 5) retaining transmission joint bracket to the transmission on the right side.

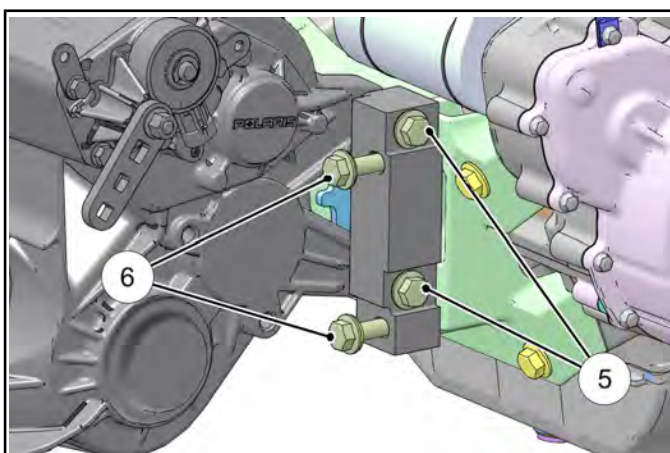

9. Align the front transmission mounting holes with transmission joint bracket mounting holes on engine.

10. Install the two bolts (Item 6) retaining the transmission joint bracket to the engine on the right side. Hand tighten the bolts so they remain loose at this time.

**NOTE: DO NOT torque fasteners at this time.**

11. Install the two longer bolts into left side mounting holes. Torque left side mounting bolts to specification using the numbered sequence shown.

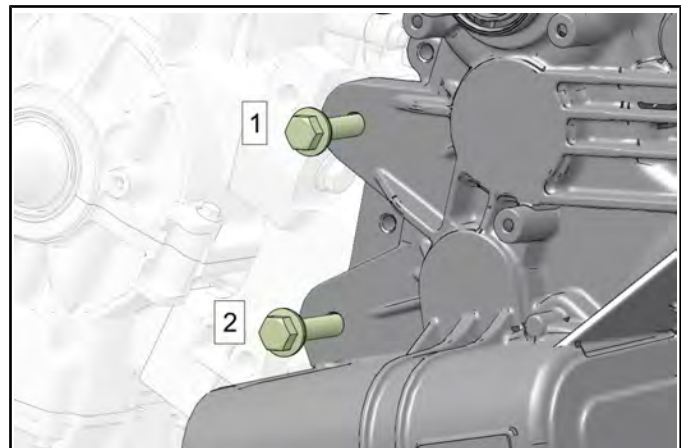

12. Torque right side mounting bolts to specification using the numbered sequence shown.

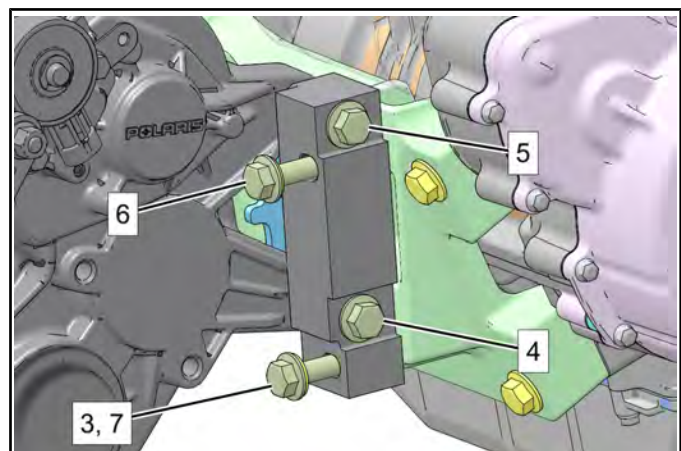

Engine / Transmission Mounting Bolts:  
**Step 1-2: 64 ft-lb (87 Nm)**  
**Step 3: 5 ft-lb (7 Nm)**  
**Step 4-7: 44 ft-lb (60 Nm)**

13. Remove the clutch center distance tool.

# ENGINE

14. Torque the four front engine mount fasteners to specification.

 = T
Front Engine Mount Fasteners: <b>40 ft-lbs (54 Nm)</b>

15. Remove the lifting straps and overhead or portable engine hoist.
16. Install the two coolant hoses onto the engine.
17. Install front support bracket (Item 7) and rear support (Item 8) onto the vehicle frame. Torque fasteners to specification.

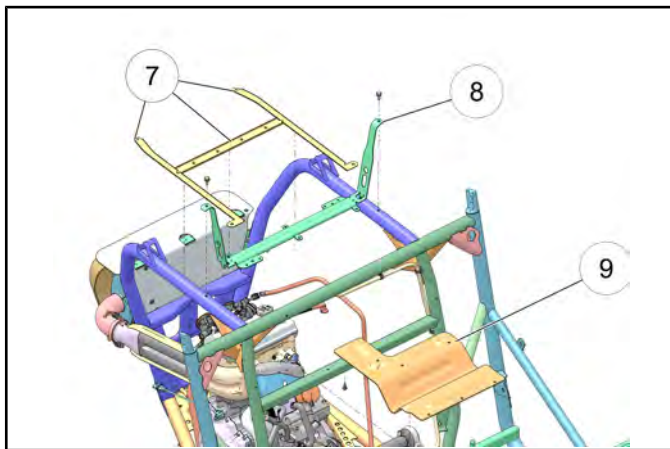

18. Install push rivet through heat shield (Item 9) into rear cross member.
19. Install the exhaust heat shield and push rivets.
20. Replace exhaust gaskets (seals). Install exhaust head pipe. Install the six fasteners that attach the exhaust head pipe to the engine and torque to specification.

 = T
Exhaust Head Pipe Bolts: <b>18 ft-lb (24 Nm)</b>

21. Install the two exhaust springs that attach the head pipe to the muffler.
22. Install the breather hose to the crankcase.
23. Install the spark plug wires to the appropriate cylinder by referencing the MAG and PTO spark plug wire decals.

**NOTE: Ensure plug wires caps are pushed down all the way so they engage onto the spark plugs.**

24. Install the throttle body assembly and connect fuel lines. Install throttle cable retaining clip.
25. Secure wire harness in the routing clip on the rear cross member.
26. Install (+) positive cable to the starter motor.
27. Install (-) negative cable to the starter motor mounting bolt.
28. Properly route and connect the harness leads for the stator, CPS, TMAP sensor, ECT sensor, fuel injectors and ignition coil.
29. Install the air box assembly as outlined in the EFI Chapter (See ETC Replacement, page 4.33).
30. Install the inner clutch cover, drive clutch, driven clutch, drive belt, outer clutch cover and clutch outlet duct (see Chapter 6).
31. Install the left rear shock lower mounting bolt and new nut. Torque to specification.

 = T
Rear Shock Mounting Bolt: <b>70 ft-lbs (95 Nm)</b>

32. Install the left rear wheel and torque wheel nuts to specification.

 = T
Wheel Nuts: <b>120 ft-lbs (163 Nm)</b>

33. Install the rear bumper and cargo box as an assembly.

**NOTE: Be sure to connect the engine intake hose and clutch air intake hose to the rear cargo box asm upon installation.**

34. Connect the (-) negative battery cable.
35. Remove the pressure cap and fill the cooling system through the filler neck with properly mixed anti-freeze / coolant.
36. Install a new oil filter. Lubricate the seal with engine oil prior to installation (see Chapter 2 "Maintenance").
37. Add approximately 2.5 quarts (3.3 L) of Polaris PS-4 or PS-4 Extreme Duty Synthetic Engine Oil to the engine. Additional oil may be required after complete engine disassembly. Check level after filling and add oil as needed.

38. Follow the Cooling System Bleeding Procedure, page 3.18 as outlined in this chapter.
39. Install the seats.
40. Start engine and check for any oil or coolant leaks.

41. Check the engine oil level.
42. Refer customer to "Engine Break-In Period" upon returning vehicle to customer.

## Engine Mounting and Torque Values

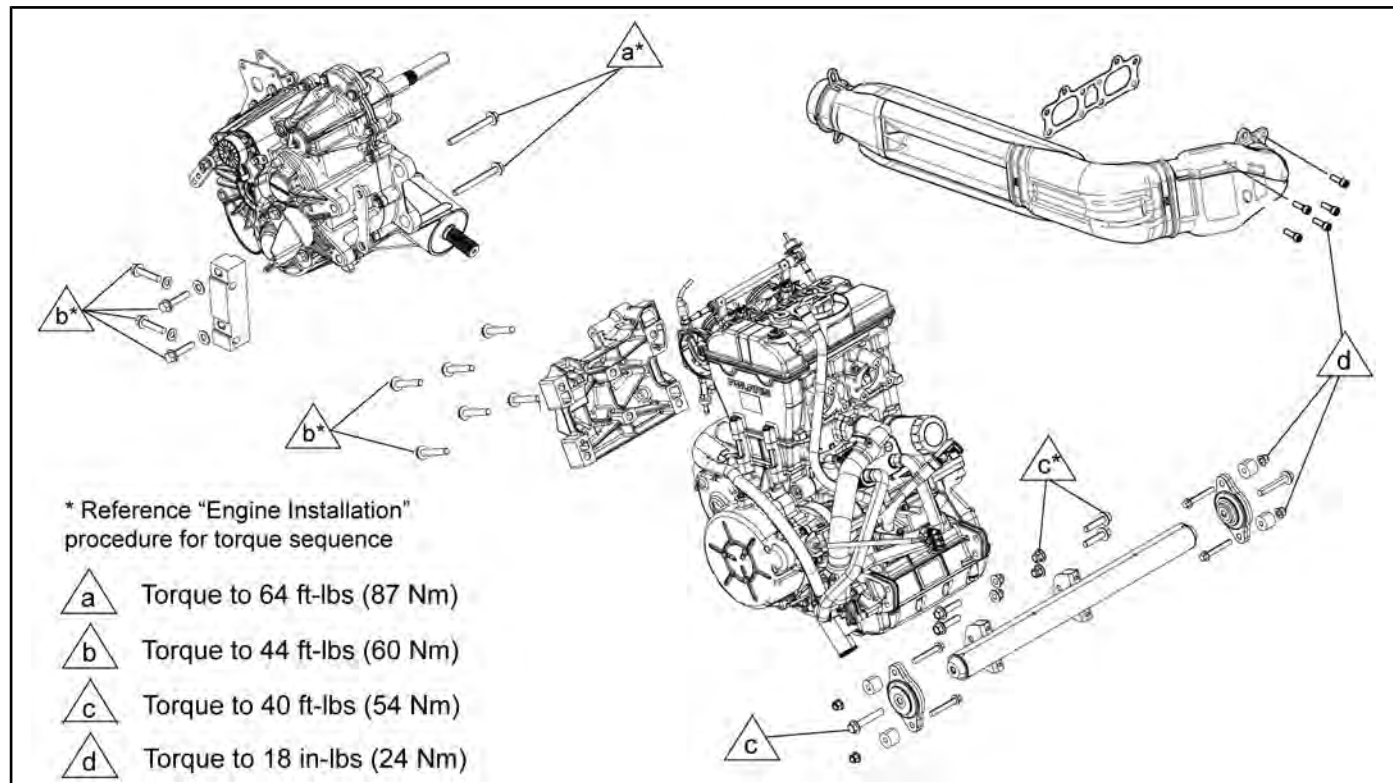

# ENGINE

## Engine Break-In Period

The break-in period consists of the first 25 hours of operation, or the time it takes to use 15 gallons (57 liters) of fuel. Careful treatment of a new engine and drive components will result in more efficient performance and longer life for these components.



### CAUTION

Use only Polaris PS-4 or PS-4 Extreme Duty Synthetic 4-Cycle Engine Oil.

Never substitute or mix oil brands. Serious engine damage and voiding of warranty can result.

Do not operate at full throttle or high speeds for extended periods during the first three hours of use. Excessive heat can build up and cause damage to close fitted engine parts.

1. Fill fuel tank with unleaded fuel which has a minimum pump octane number of  $87 = (R + M)/2$ .
2. Refer to Engine Oil Level, page 2.16. Check oil level indicated on dipstick. Add oil if necessary.
3. Drive slowly at first to gradually bring engine up to operating temperature.
4. Vary throttle positions. Do not operate at sustained idle or sustained high speed.
5. Perform regular checks on fluid levels, controls and all important bolt torques.
6. Change oil and oil filter after 25 hour break-in period.

## Engine Lubrication Specifications



### Oil Capacity \*

Approx. 2.5 Quarts (2.4 L)

### Oil Filter Wrench

PU-50105 or 2.5" (64 mm)

### Oil Filter

PN 2540086

### Oil Type

*Ambient Temp Range:*

*-35° F to 100° F*

PS-4 Synthetic Engine oil  
(PN 2876244) (Quart)

*Ambient Temp Range:*

*0° F to 120° F*

PS-4 Extreme Duty  
Synthetic Engine Oil  
(PN 2878920) (Quart)

### Oil Pressure

#### Minimum Specification

(using Polaris engine oil at operating temperature)

10 PSI @ 1200 RPM

40 PSI @ 7000 RPM

\* Additional oil may be required after complete engine disassembly. Check level after filling and add oil as needed.

## ENGINE DISASSEMBLY / INSPECTION - TOP END

### Valve Cover Removal

**NOTE:** The valve cover can be removed with the engine installed in the chassis.

1. Remove the four valve cover shoulder bolts (Item 1) and isolators (Item 2) using a T40 driver.

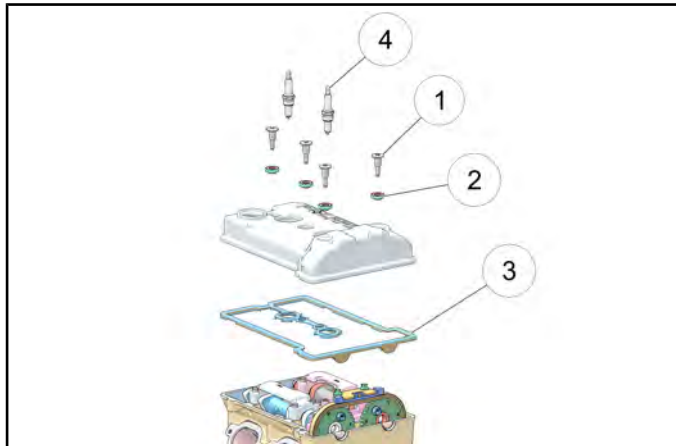

2. Replace isolators (Item 2) when they are removed and replace valve cover seal (Item 3) if oil leaks are evident.
3. Remove the spark plugs (Item 4). Stuff spark plug holes with shop towels to prevent anything from falling into the combustion chamber.

### Camshaft Removal

**NOTE:** The camshafts can be removed with the engine installed in the chassis.

1. Rotate the engine so the PTO cylinder is at Top Dead Center (TDC) to relieve most of the valve spring pressure. The camshaft lobes should face out (Item 1) and the slots on the end of the camshafts should line up.

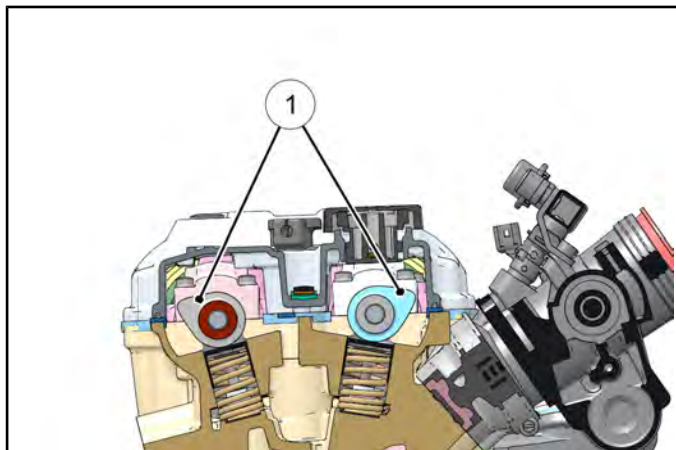

2. Remove the hydraulic cam chain tensioner (Item 2) from the cylinder. Replace the sealing washer (Item 3) upon reassembly.

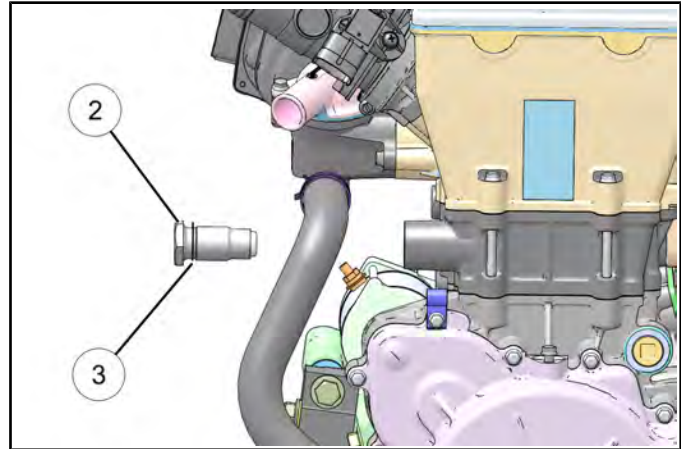

3. Remove the two bolts retaining the fixed cam chain guide (Item 4) and remove the assembly from the engine.

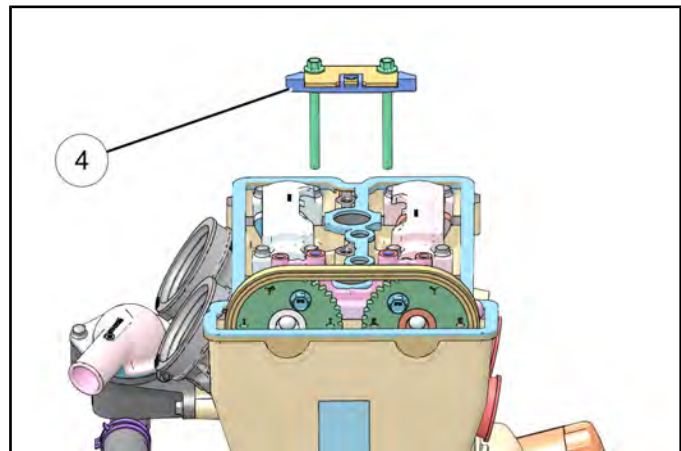

4. Remove the remaining two bolts that retain the front camshaft carrier (Item 5) and carefully lift the carrier off the camshafts.

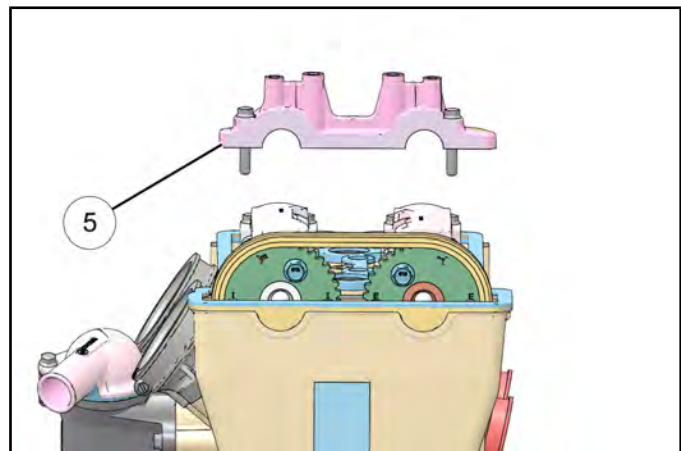

## ENGINE

5. Hold camshafts (Item 6) with an open-end wrench, and remove the top bolt (Item 7) from the camshaft sprockets (Item 8).

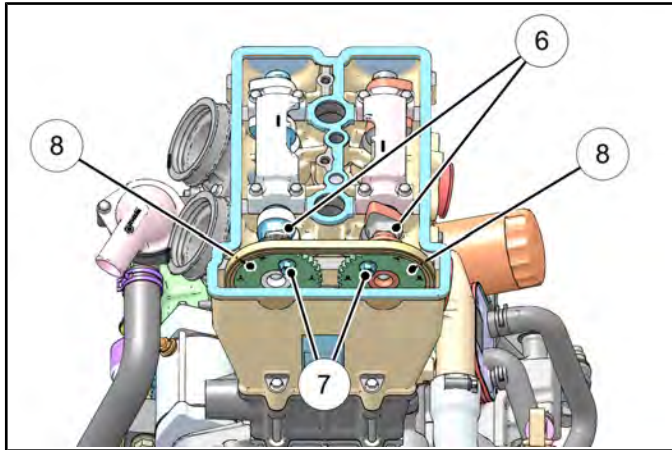

6. Rotate the engine using the flywheel and remove the remaining bolt from each camshaft sprocket.
7. Lift the chain and sprockets off the camshafts to allow each sprocket to be removed.
8. Using a paperclip or other tool, hold cam chain up to keep it from falling down into the crankcase.

**NOTE: The crankcase has a built-in lower guide to prevent the chain from falling off the crankshaft.**

9. Evenly loosen the four bolts retaining each rear camshaft carrier (Item 10) and carefully lift the carriers off the camshafts.

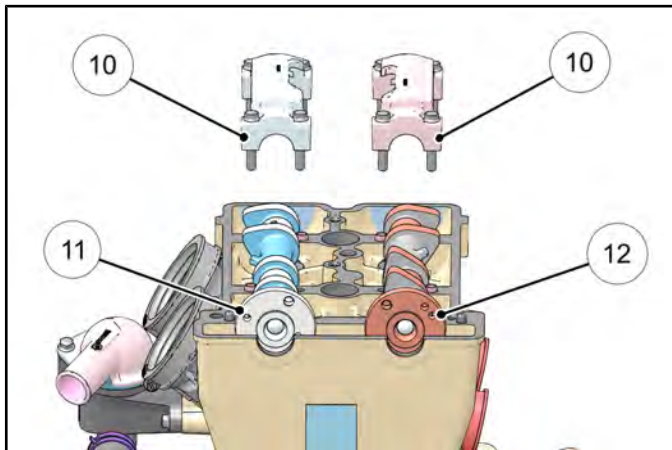

10. Mark the intake (Item 11) and exhaust (Item 12) camshafts to ensure proper assembly.
11. Carefully remove camshafts from the cylinder head.

### Camshaft Sprocket Inspection

Inspect cam sprocket teeth (Item 1) for wear or damage. Replace timing chain and sprockets if worn or damaged.

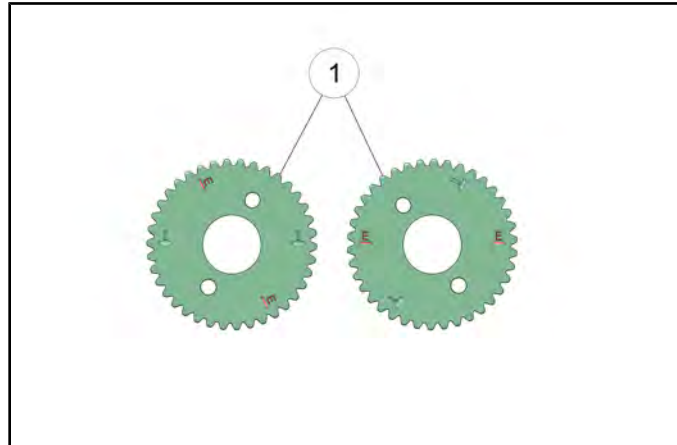

### Camshaft / Camshaft Bore Inspection

Inspect all main journals and cam lobes as described below and compare to specifications. Replace camshaft (s) or cylinder head if worn beyond service limit or if any surface is pitted or damaged.

1. Visually inspect each cam lobe for wear or damage.

2. Measure the height of each cam lobe from the base circle to highest point on the lobe using a micrometer. Compare to specification.

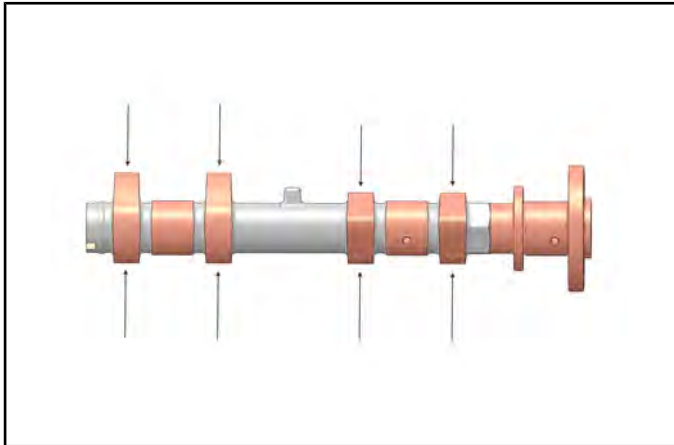

**NOTE: Replace camshafts if damaged or if any part is worn past the service limit.**

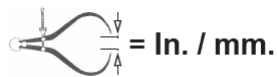

Camshaft Lobe Height:  
 Intake: **1.5390 - 1.5429" (39.09 - 39.19 mm)**  
 Service Limit: **1.5370" (39.04 mm)**  
 Exhaust: **1.5142 - 1.5181" (38.46 - 38.56 mm)**  
 Service Limit: **1.5122" (38.41 mm)**

3. Visually inspect each camshaft journal for scoring, wear or damage.

4. Measure the diameter of the camshaft journals using a micrometer. Compare to specification.

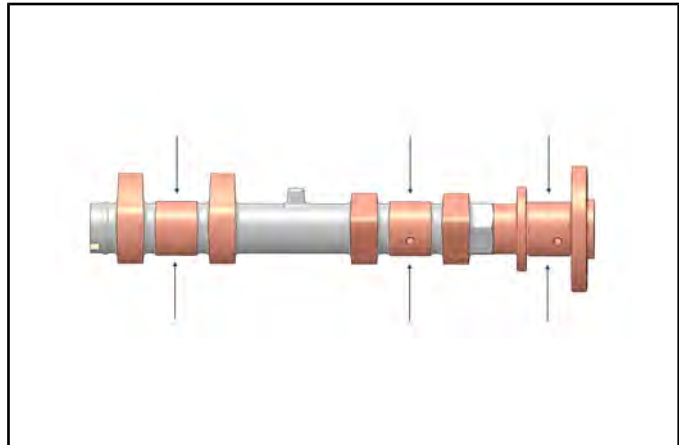

**NOTE: Replace camshafts if damaged or if any part is worn past the service limit.**

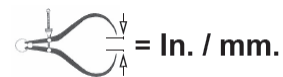

Camshaft Journal O.D.:  
**0.9036 - 0.9055" (22.954 - 22.999 mm)**  
**0.9033" (22.944 mm)**

5. Temporarily install the camshaft carriers to measure the camshaft bore. Torque bolts in sequence to specification. Replace cylinder head if worn.

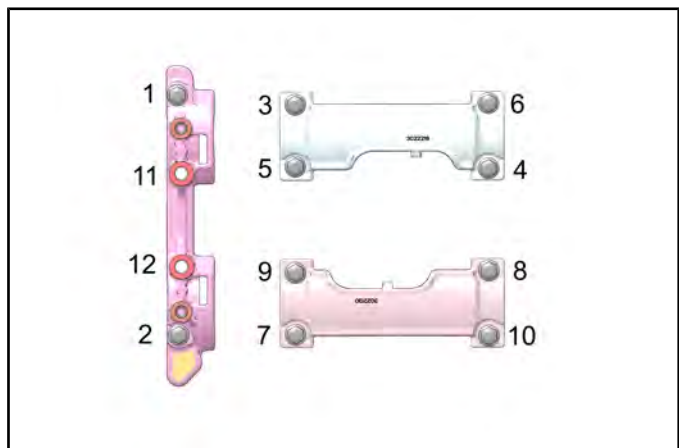

Camshaft Carrier Bolts:  
**89 in-lbs (10 Nm)**



# ENGINE

6. Measure camshaft bore and compare to specifications.

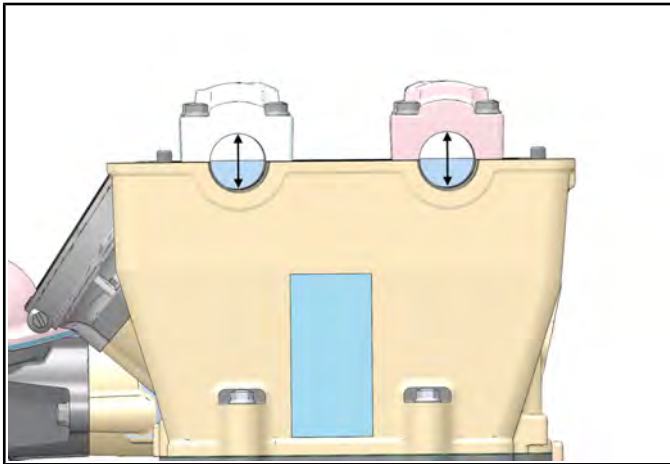

**NOTE:** Replace cylinder head if camshaft journal bores are damaged or if worn past the service limit.

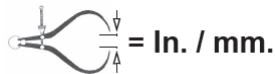

Camshaft Carrier Bore I.D.:  
**0.9055 - 0.9063" (23.000 - 23.021 mm)**

**0.9072" (23.044 mm)**

7. Calculate oil clearance by subtracting camshaft journal O. D. s from camshaft carrier bore I. D. s. Compare to specification.

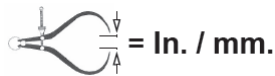

Calculated Camshaft Oil Clearance:  
**0.0000 - 0.0026" (0.001 - 0.067 mm)**  
**0.0039" (0.1 mm)**

## Cylinder Head Removal

**NOTE:** The cylinder head can be serviced with the engine installed in the chassis.

1. Remove the two outer M6 bolts (Item 1) that retain the cylinder head (Item 2) to the cylinder.

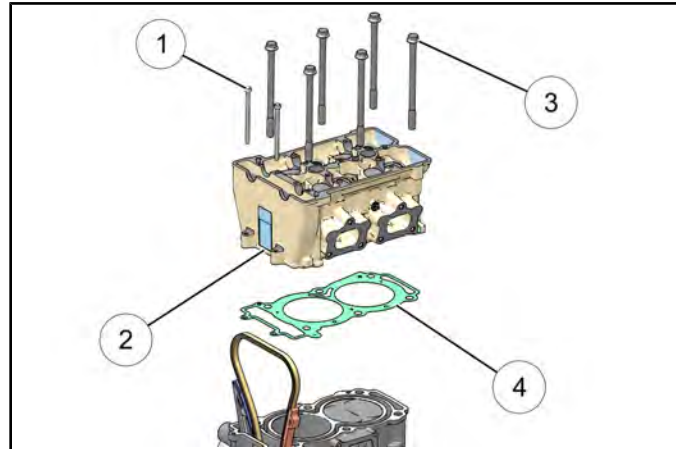

2. Loosen the six cylinder head bolts (Item 3) evenly 1/8 turn at a time until all are loose.
3. Remove and discard the cylinder head bolts.
4. Tap cylinder head lightly with a soft faced hammer until loose.
5. Tap only in reinforced areas or on thick parts of the cylinder head casting.
6. Remove the cylinder head and head gasket (Item 4).

**NOTE:** Once the cylinder head is removed, nothing retains the cylinder to the engine. **DO NOT** rotate the engine without using the Cylinder Holding & Camshaft Timing Plate (PU-50563). Refer to Cylinder / Piston Removal, page 3.54.

## Cylinder Head Warp Inspection

Thoroughly clean cylinder head surface to remove all traces of gasket material and carbon.

### CAUTION

Use care not to damage gasket sealing surface. All gasket surfaces must be clean, dry and free of any oil or grease upon assembly. Clean sealing surfaces with rubbing alcohol or electrical contact cleaner. Do not touch sealing surfaces of the new head gasket.

1. Lay a straight edge (Item 1) across the surface of the cylinder head at several different points and measure warp by inserting a feeler gauge between the straight edge and the cylinder head surface. If warp exceeds the service limit, replace the cylinder head.

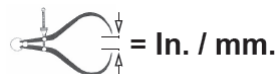
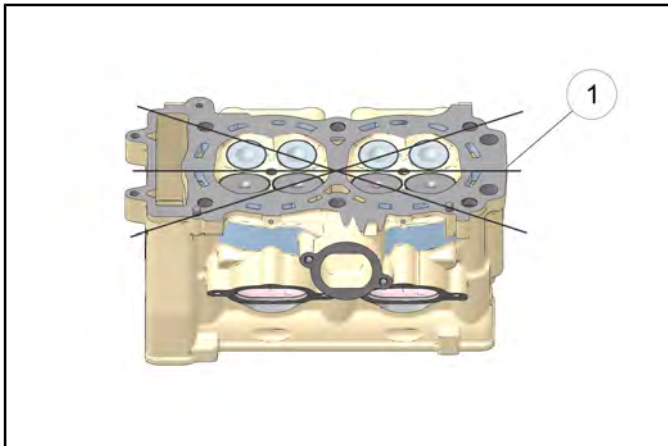

Cylinder Head Warp Limit:  
**0.0039" (0.1 mm)**

**NOTE:** Keep mated parts together and in order with respect to their location in the cylinder head for assembly purposes. It is important to install cylinder head components back in the same location. Mark each component or place them in an organized rack as you remove them.

1. Remove the valve tappet (Item 1) from the cylinder head. Note the tappet size (Item 2) engraved on the underside of the bucket.

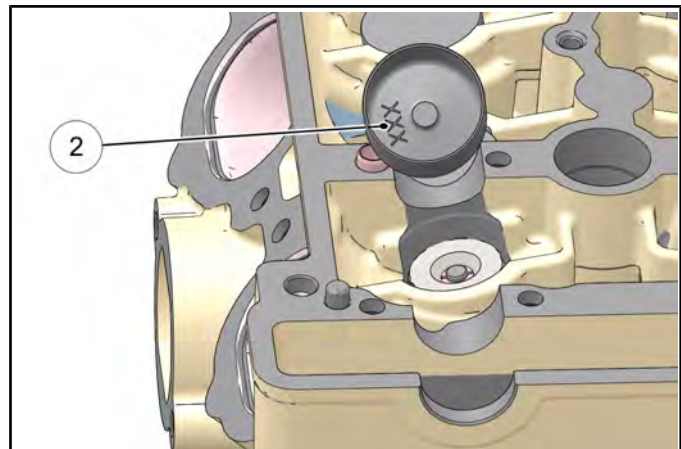
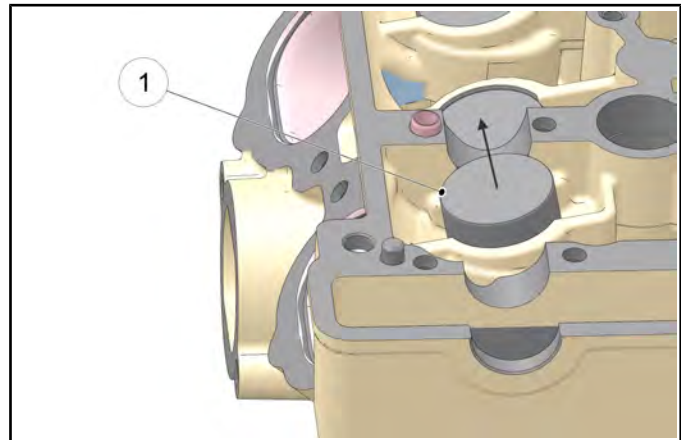

3

## Cylinder Head Disassembly

### WARNING

Wear eye protection during cylinder head disassembly and reassembly or when working with the valve springs.

# ENGINE

2. Compress the valve spring by hand using valve spring compressor adapter (PV-43513-A).

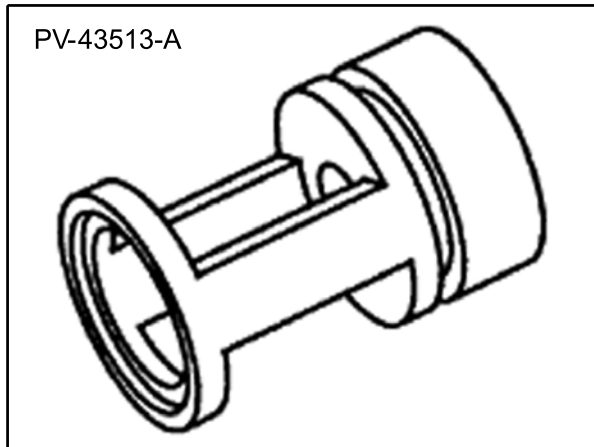

3. Push down on spring and remove split keepers (Item 3).

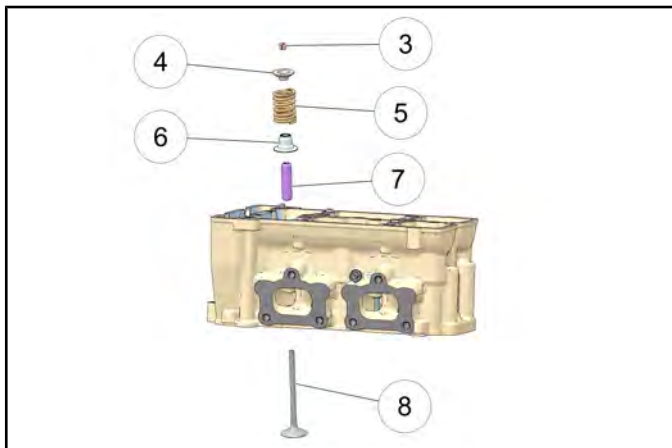

4. Slowly release valve spring pressure and remove the compressor adapter.
5. Remove the valve retainer (Item 4), valve spring (Item 5), valve stem seal (Item 6) and valve spring seat (Item 7). Discard the valve seal.

**NOTE: Replace valve seals whenever cylinder head is disassembled. Hardened, cracked or worn seals will cause excessive oil consumption.**

6. Lift up the cylinder head and push the valve (Item 8) out, keeping it in order for reassembly in the same valve guide.
7. Repeat the previous steps to remove the remaining valves.
8. Clean the combustion chamber and head gasket surface.
9. Check the condition of each valve spring. Replace if wear or cracking is present on the spring.

## Valve Inspection

1. Remove all carbon from valves with a soft wire wheel or brush.
2. Check valve face for runout, pitting, and burnt spots. To check for bent valve stems, mount valve in a drill or use "V" blocks and a dial indicator.

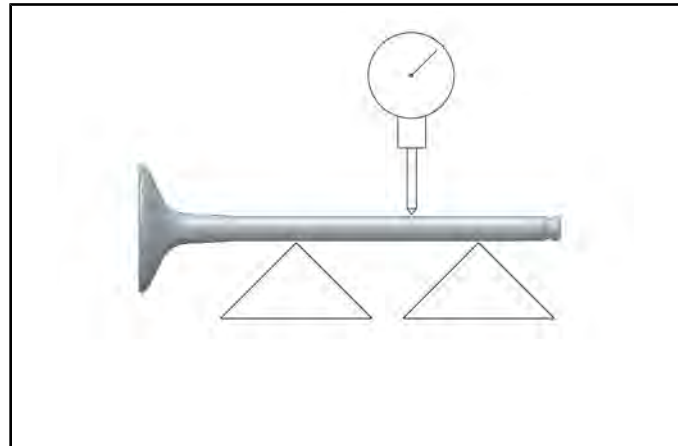

3. Check the end of the valve stem for flaring, pitting, wear or damage.



4. Inspect split keeper groove for wear or flaring in the keeper seat area.

**NOTE: The valves can be re-faced or end ground, if necessary. They must be replaced if extensively worn, burnt, bent or damaged.**

5. Measure diameter of valve stem with a micrometer in three places, then rotate 90° and measure again (take six measurements total). Compare to specifications.

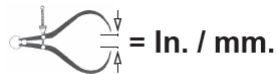
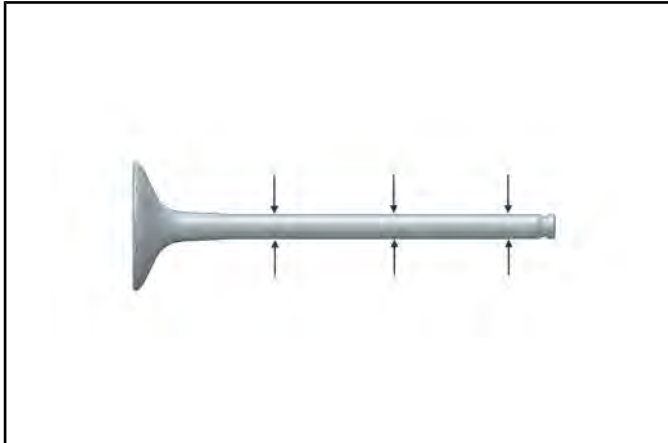

Valve Stem Diameter:  
**Intake: 0.2155 - 0.2161" (5.475 - 5.490 mm)**  
**Exhaust: 0.2147 - 0.2153" (5.455 - 5.470 mm)**

6. Measure valve guide inside diameter at the top, middle and end of the guide using a small hole gauge and a micrometer. Measure in two directions.

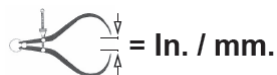
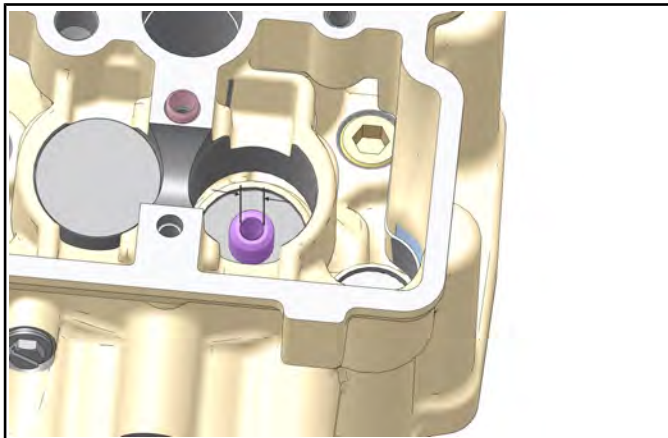

Valve Guide I.D.:  
**0.2165 - 0.2171" (5.500 - 5.515 mm)**

7. Be sure to measure each guide and valve combination individually.

**NOTE: The valve guides cannot be replaced.**

## Combustion Chamber Cleaning

### WARNING

Wear eye protection during combustion chamber cleaning.

1. Clean all accumulated carbon deposits from combustion chambers and valve seat area (Item 1).

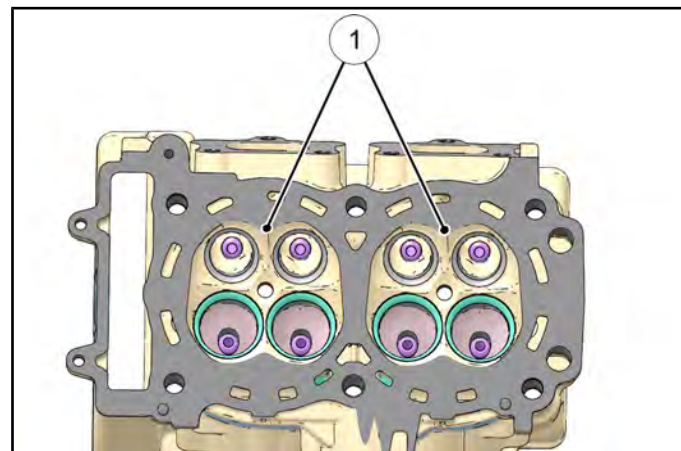

**NOTE: Carbon Clean Fuel Treatment (2871326) can be used to help remove carbon deposits.**

**Do not use a metal scraper, a coarse wire brush or abrasive cleaners to clean the cylinder head. Damage may result.**

2. Visually inspect cylinder head gasket surface and combustion chamber for cracks or damage. Pay close attention to areas around spark plug and valve seats.

## Valve Sealing Test

1. Clean and dry the combustion chamber area (Item 1).

# ENGINE

2. Pour a small amount of clean solvent into each intake port (Item 2) and check for leakage around the valves. The valve seats should hold fluid with no seepage.

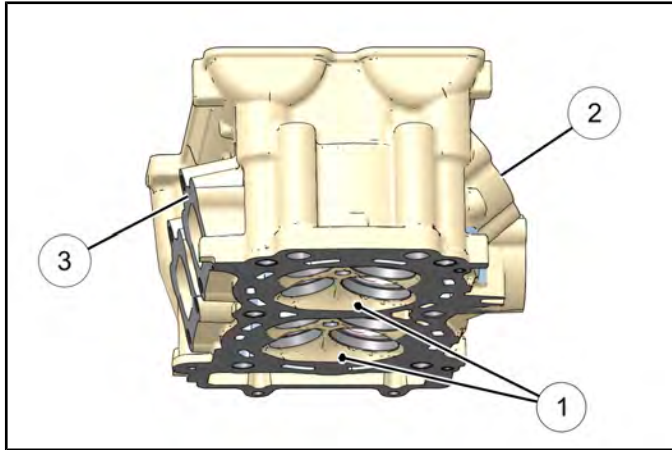

3. Repeat for exhaust valves by pouring fluid into each exhaust port (Item 3).

## Valve Seat Reconditioning

Valve seat reconditioning should be performed by a technician proficient in cylinder head reconditioning techniques. Reconditioning techniques vary, so follow the instructions provided by the valve reconditioning equipment manufacturer. Do not grind seats more than necessary to provide proper seat surface, width, and contact point on valve face.

### WARNING

Wear eye protection or a face shield during cylinder head disassembly and reassembly.

## Valve Seat Inspection

Inspect valve seat in cylinder head for pitting, burnt spots, roughness, and uneven surface. If any of the above conditions exist, the valve seat must be reconditioned. *If the valve seat is cracked the cylinder head must be replaced.*

Valve seat width and point of contact on the valve face is very important for proper sealing. The valve must contact the valve seat over the entire circumference of the seat, and the seat must be the proper width all the way around. If seat is uneven, compression leakage will result. If seat is too wide, seat pressure is reduced, causing carbon accumulation and possible compression loss. If seat is too narrow, heat transfer from valve to seat is reduced. The valve may overheat and warp, resulting in burnt valves.

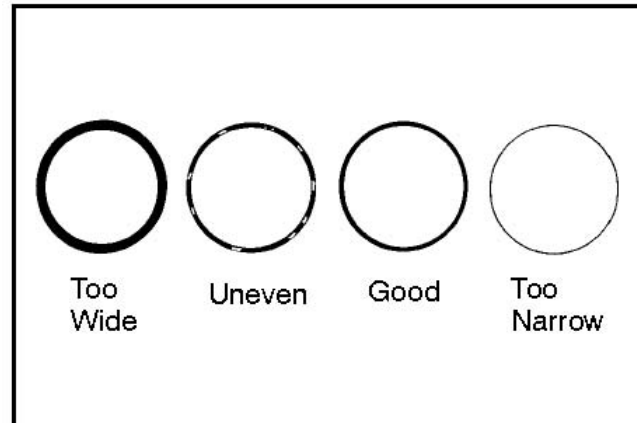

## Renewing Valve Seats

1. Install pilot into valve guide.
2. Apply cutting oil to valve seat and cutter.
3. Place 46° cutter on the pilot and make a light cut.
4. Inspect the cut area of the seat:

\* If the contact area is less than 75% of the circumference of the seat, rotate the pilot 180° and make another light cut.

\* If the cutter now contacts the uncut portion of the seat, check the pilot. Look for burrs, nicks, or runout. If the pilot is bent it must be replaced.

\* If the contact area of the cutter is in the same place, the valve guide is distorted from improper installation.

\* If the contact area of the initial cut is greater than 75%, continue to cut the seat until all pits are removed and a new seat surface is evident.

**NOTE: Remove only the amount of material necessary to repair the seat surface.**

5. To check contact area of the seat on the valve face, apply a thin coating of Prussian Blue™ paste to the valve seat. If using an interference angle (46°) apply black permanent marker to the entire valve face (Item 1).

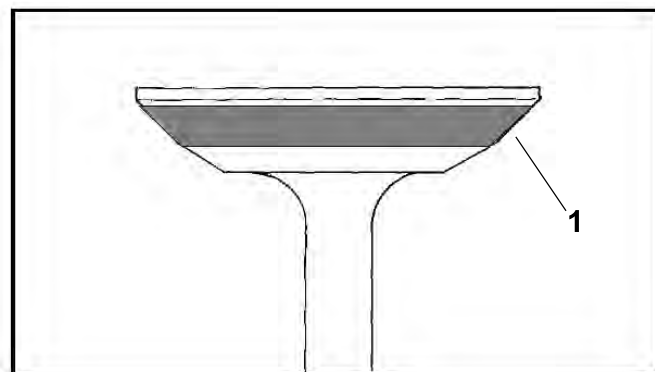

6. Insert valve into guide and tap valve lightly into place a few times.

7. Remove valve and check where the Prussian Blue™ indicates seat contact on the valve face. The valve seat should contact the middle of the valve face or slightly above, and must be the proper width.

\* If the indicated seat contact is at the top edge of the valve face and contacts the margin area (Item 2) it is too high on the valve face. Use the 30° cutter to lower the valve seat.

\* If too low, use the 60° cutter to raise the seat. When contact area is centered on the valve face, measure seat width.

\* If the seat is too wide or uneven, use both top and bottom cutters to narrow the seat.

\* If the seat is too narrow, widen using the 45° cutter and re-check contact point on the valve face and seat width after each cut.

**NOTE:** When using an interference angle, the seat contact point on the valve will be very narrow, and is a normal condition. Look for an even and continuous contact point all the way around the valve face (Item 3).

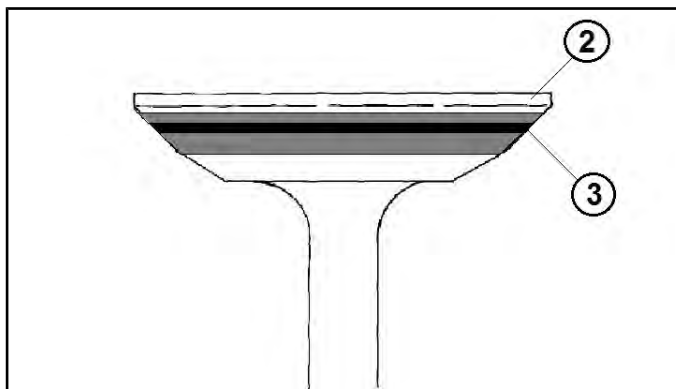

**Intake Seat Cutter Diameter: 1.567" (39.80 mm)**

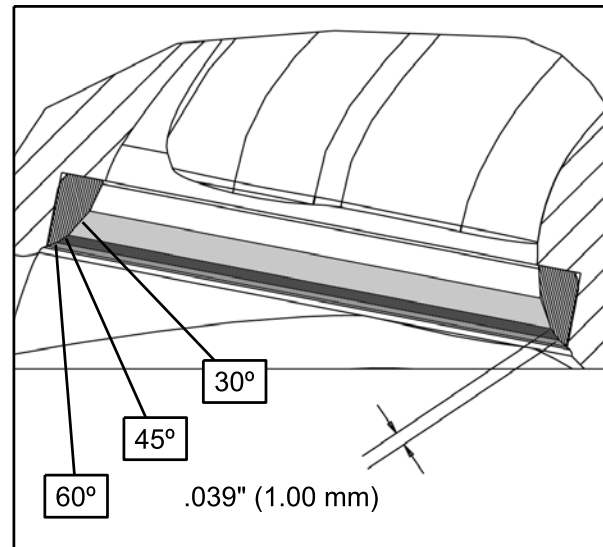

**Exhaust Seat Cutter Diameter: 1.364" (34.65 mm)**

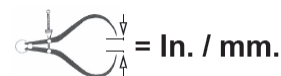
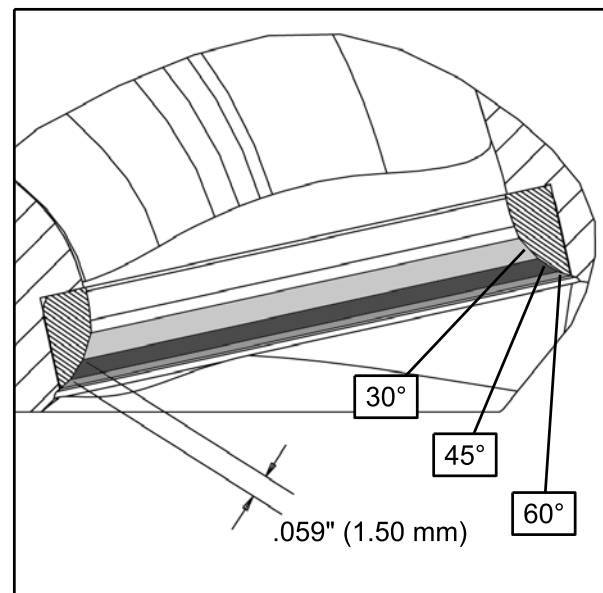

Valve Seat Width:  
**Intake: 0.0393 ± 0.0039" (1.0 ± 0.10 mm)**  
**Service Limit: 0.0551" (1.4 mm)**  
**Exhaust: 0.0590 ± 0.0039" (1.5 ± 0.10 mm)**  
**Service Limit: 0.0748" (1.9 mm)**

3

## ENGINE

---

8. Clean all filings from the area with hot soapy water. Rinse and dry with compressed air.
9. Lubricate valve guides with clean engine oil and apply oil or water based lapping compound to the face of the valve.

**NOTE: Lapping is not required if an interference angle reconditioning method is used.**

10. Insert the valve into its respective guide and lap using a lapping tool or a section of fuel line connected to the valve stem.
11. Rotate the valve rapidly back and forth until the cut sounds smooth. Lift the valve slightly off of the seat, rotate 1/4 turn, and repeat the lapping process. Do this four to five times until the valve is fully seated, and repeat process for the other valve(s).
12. Thoroughly clean cylinder head and valves.

**ENGINE DISASSEMBLY / INSPECTION - LOWER END**

**Stator Cover Removal / Inspection**

**NOTE:** The stator cover can be removed with the engine installed in the chassis.

1. Remove the thirteen screws retaining the stator cover.

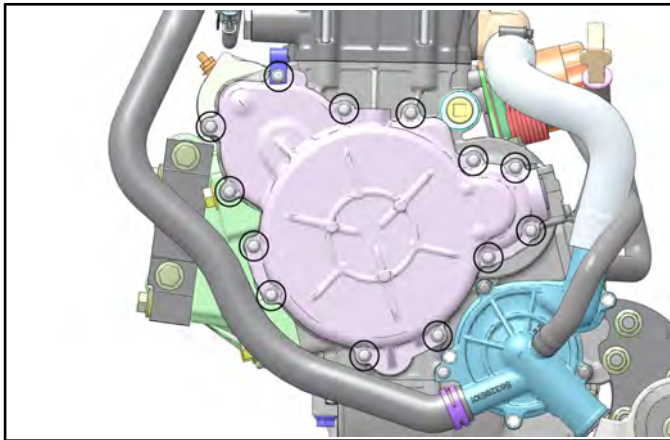

**CAUTION**

The flywheel contains powerful magnets. Use caution when removing and installing the stator cover. DO NOT place fingers between cover and crankcase at any time during the removal / installation process or injury could result.

2. Carefully pry the stator cover off the engine using the two pry areas as shown.

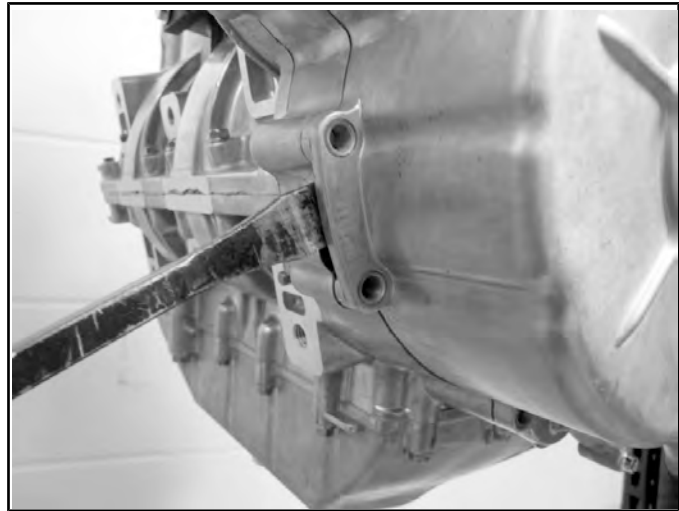

3. Inspect the condition of the stator windings (Item 1) and output wires (Item 2). If replacement is required, refer to Chapter 10.

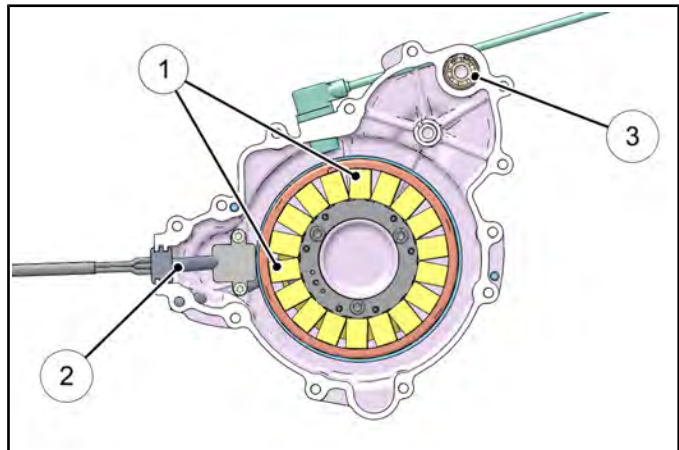



# ENGINE

4. Inspect the ball bearing (Item 3) that supports the starter motor shaft.
5. If bearing replacement is required, remove the retaining ring and heat the stator cover around the bearing evenly with a heat gun. Tap cover on a soft work surface to remove the bearing from the housing. A blind bearing puller can also be used. Replace bearing if removed.

## Water Pump Housing Removal

**NOTE:** The water pump housing can be serviced with the engine installed in the chassis (see Water Pump Removal, page 3.19).

1. Remove the coolant lines from the thermostat housing, cylinder inlet and oil cooler. Leave them all attached to the water pump housing.

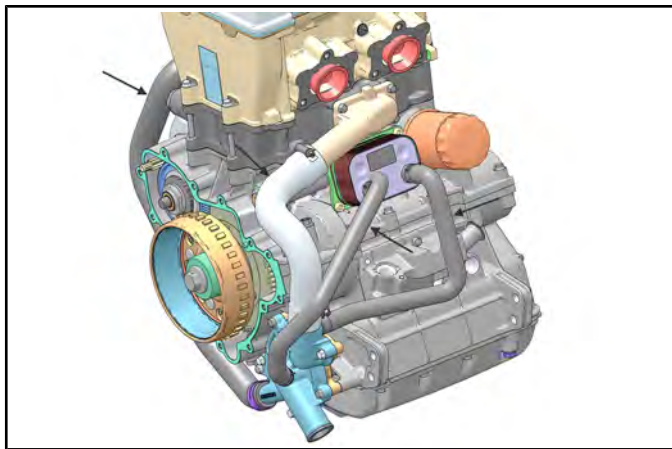

2. Remove the three long gold colored bolts retaining the water pump housing to the engine.

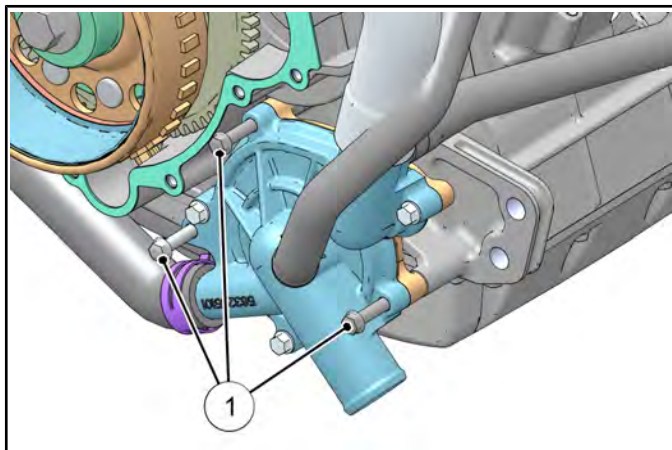

3. Remove the water pump assembly from the engine by using a twisting motion as you pull out on the housing.

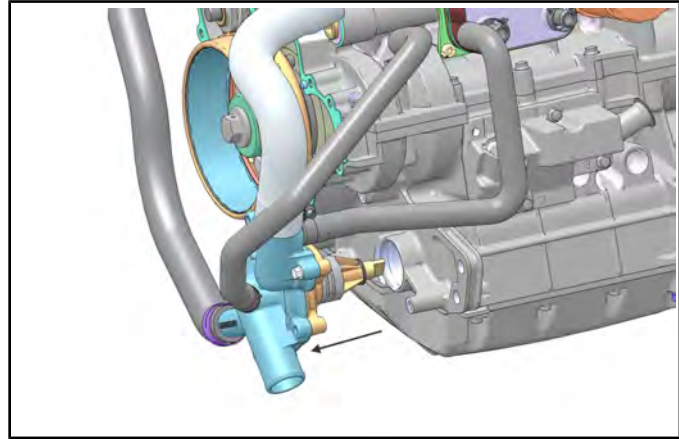

4. If water pump service is required (impeller or mechanical seal), refer to Water Pump Service, page 3.21.

## Flywheel Removal

**NOTE:** The flywheel can be serviced with the engine installed in the chassis.

1. Remove the stator cover assembly.
2. Remove the starter torque limit gear as an assembly.

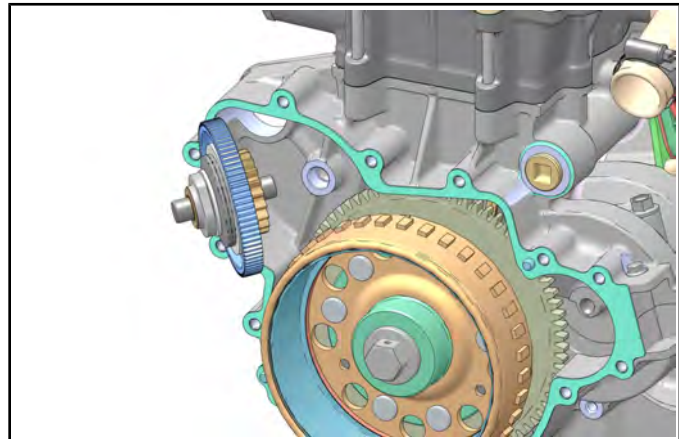

3. Inspect gear teeth for damage. Inspect fit of shaft inside gear and replace gear assembly if clearance is excessive. Inspect the shaft and bearing surfaces in the crankcase and stator cover for excessive wear.

- Using a commercially available strap wrench (Item 1), hold the flywheel and remove the flywheel retaining bolt (Item 2).

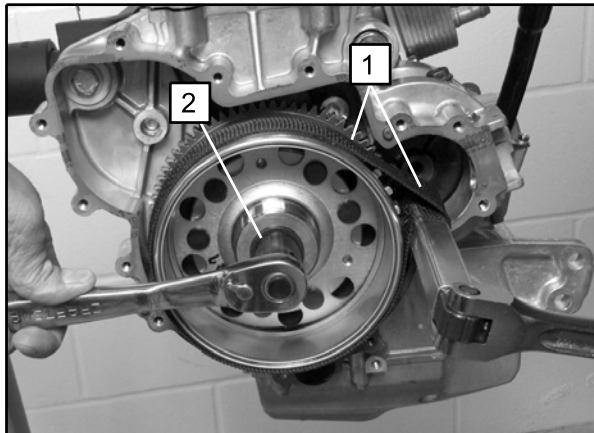

- Inspect the one-way gear bushing (Item 4) for wear or galling. If service is required, refer to “Starter One-Way Clutch Disassembly”.

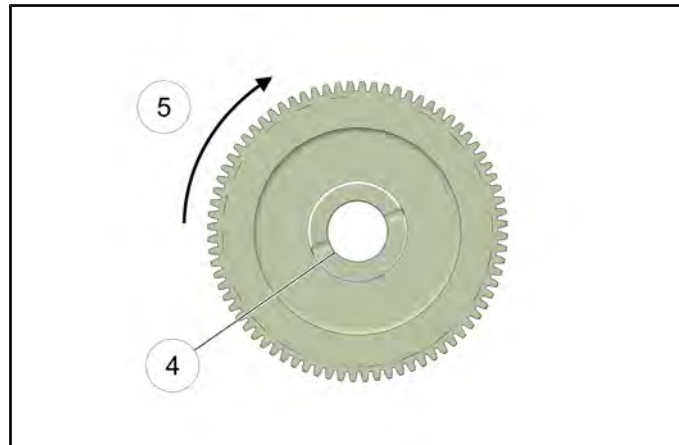

- Fully install Flywheel Puller (PA-49316) (Item 3) on the threads of the flywheel (left hand thread - turn flywheel puller counterclockwise to install).
- Hold puller body and tighten the center bolt to remove the flywheel.

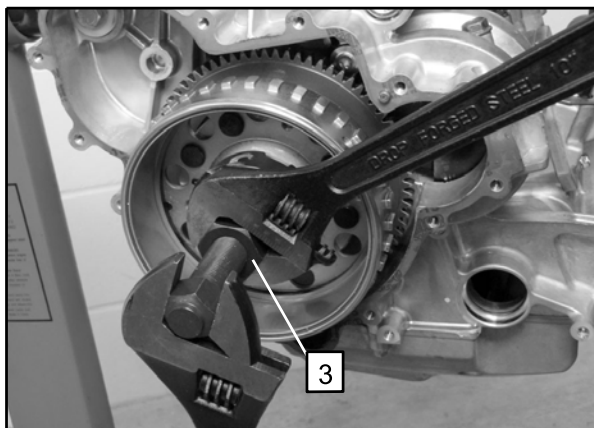

## Starter One-Way Clutch Disassembly

- Lift up to remove starter one-way gear.

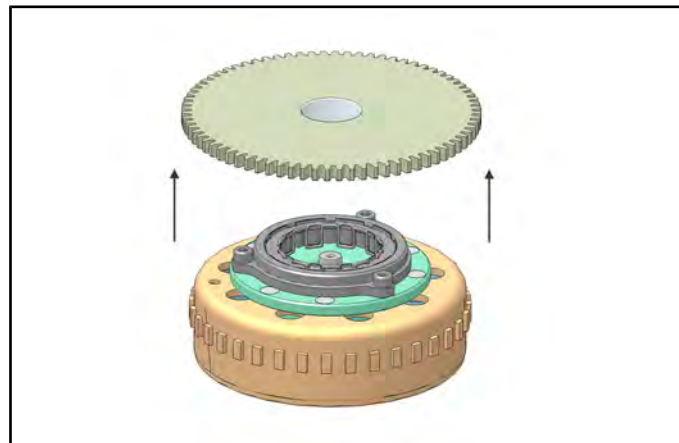

- Remove the three one-way clutch retaining screws.

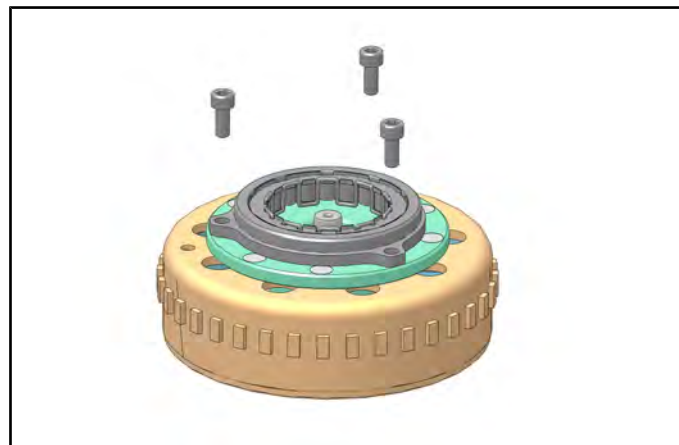

### Starter One-Way Clutch Inspection

**NOTE:** The starter one-way clutch can be serviced with the engine installed in the chassis.

- Remove the stator cover and flywheel (see “Stator Cover Removal / Inspection” and “Flywheel Removal”).
- Place flywheel on a work bench with the one-way clutch facing up. Grasp clutch gear and rotate clockwise. It should turn smoothly without binding.
- Rotate one-way gear counterclockwise (Item 5). The gear should immediately lock in position and not slip.

3

## ENGINE

3. Remove the one-way clutch and inspect both sides of drive rollers (Item 1). Inspect the roller contact surface (Item 2) inside the hub for wear, damage or uneven surface.

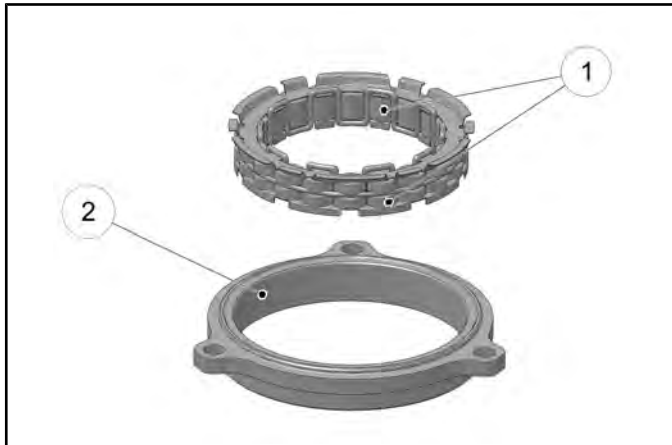

4. Inspect drive surface of starter gear (Item 3) and bushing (Item 4) for wear, damage or uneven surface. If any starter one-way clutch component is worn or damaged, replace the clutch and starter gear as an assembly.

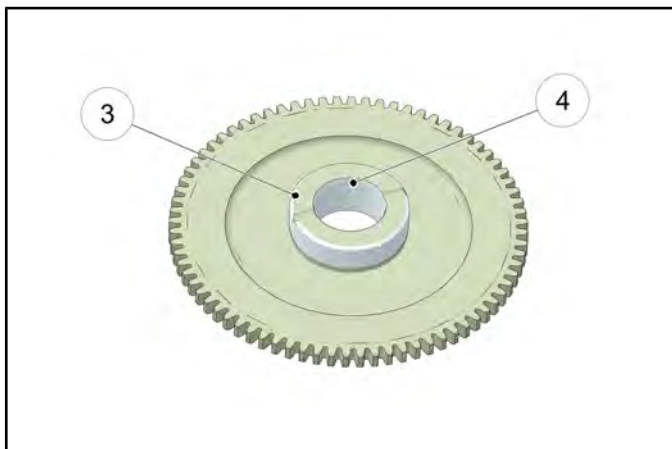

### Crankcase Disassembly / Inspection

1. Remove the oil cooler (Item 1) from the crankcase.

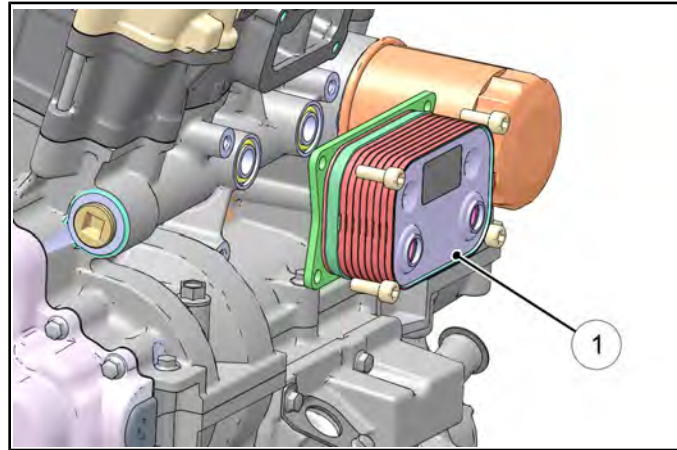

2. Remove the crankcase drain plug (Item 2). Drain any oil remaining in the engine.

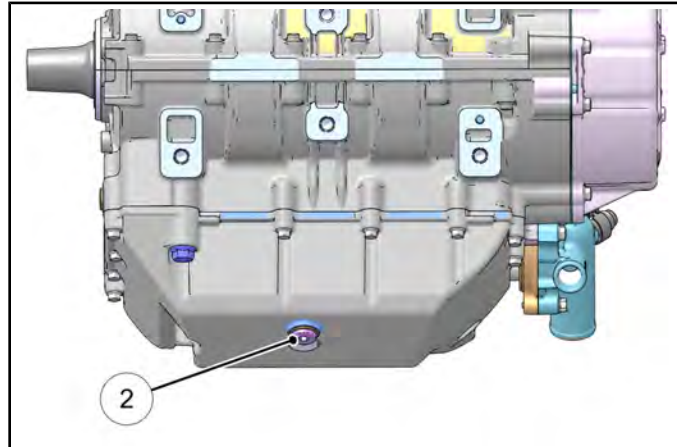

3. Remove the oil filter.

4. Install the Cylinder Holding & Camshaft Timing Plate (PU-50563) (Item 3) onto the cylinder. The cylinder holding tool retains the cylinder and pistons when the engine is rotated.

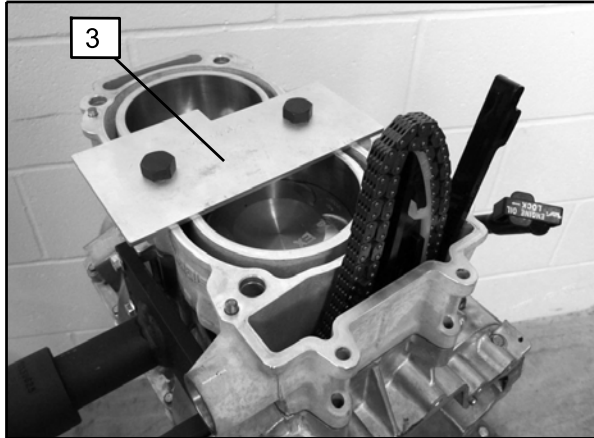

5. Rotate engine to access the crankcase sump cover.
6. Remove the thirteen M6 (Item 5) and three M8 bolts (Item 6) retaining the sump cover (Item 4) to the crankcase.

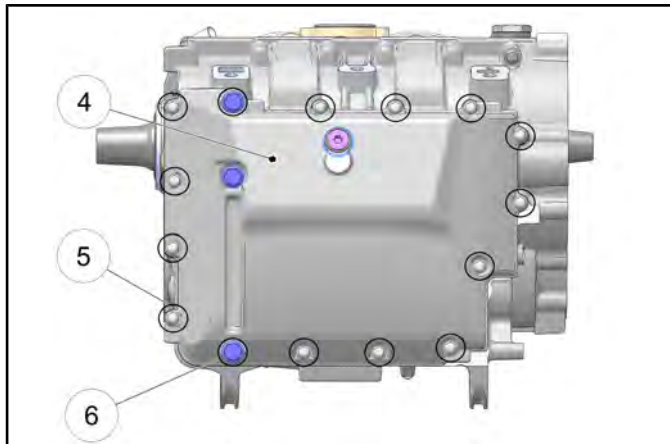

7. Remove the sump cover (Item 7) from the crankcase.

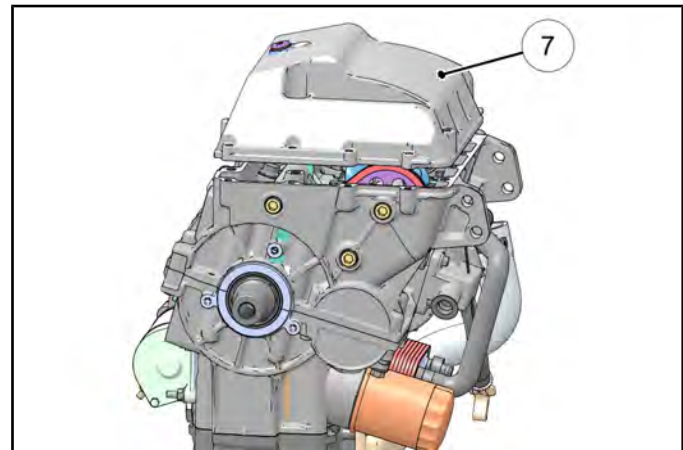

8. Remove and clean oil pump pick-up (Item 8).
9. Remove the three bolts (Item 9) that retain the oil pump (Item 10) to the crankcase.

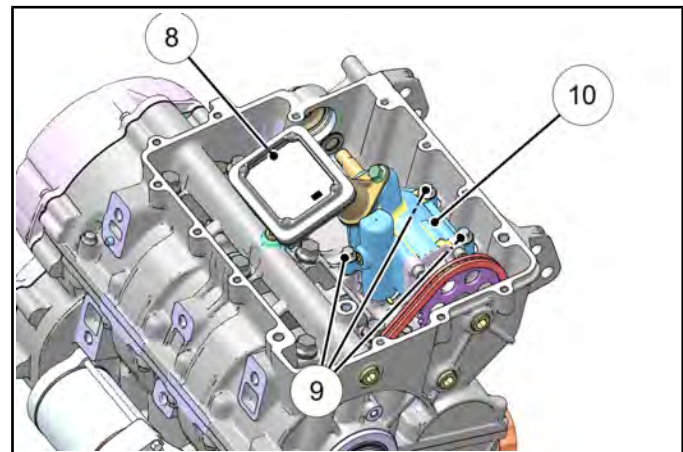

## ENGINE

10. Use one of the oil pump retaining bolts or a pen magnet to extract the dowel pins (Item 11) from the oil pump. Doing so allows for oil pump removal without having to remove the pump drive sprocket.

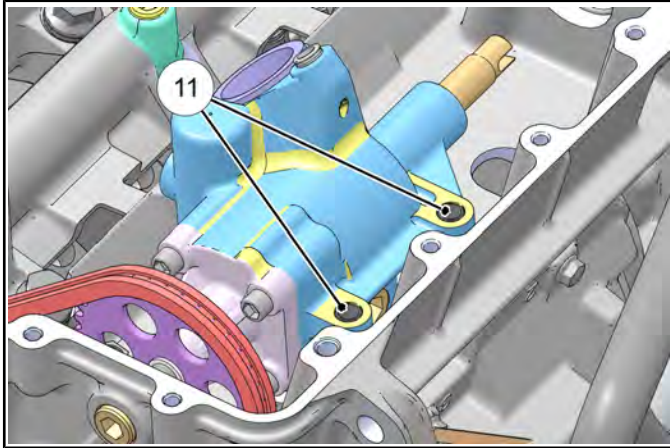

**NOTE:** If unable to extract the dowel pins from the oil pump, the oil pump sprocket must be removed. Access the sprocket bolt by removing the case plug.

11. Lift the oil pump drive chain and remove the oil pump.

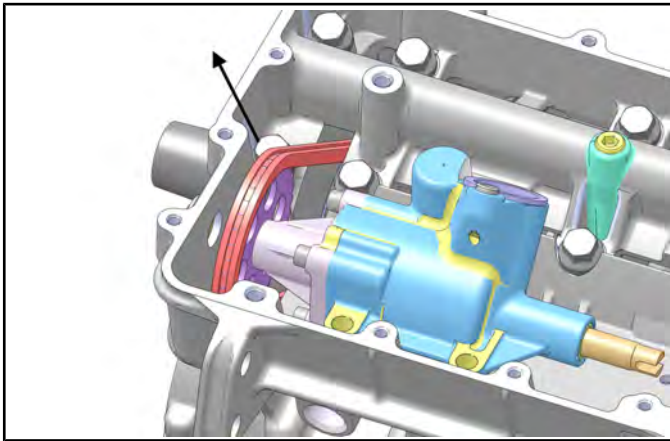

12. Visually inspect the oil pump and drive sprocket (Item 12) for wear or damage. Replace oil pump drive chain and sprocket if worn or damaged. If any part of the oil pump is damaged, the entire assembly must be replaced. Replace the oil pump seal (Item 13) during crankcase assembly.

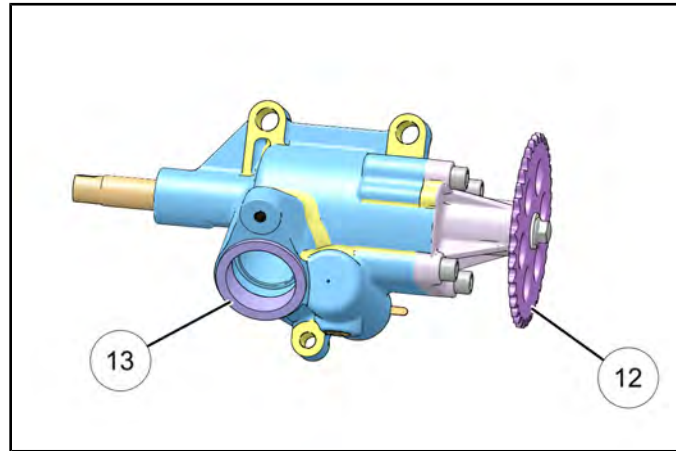

**NOTE:** Oil pump assembly is non-serviceable

13. Rotate the engine so the cylinder is facing up.
14. Remove the eleven M6 (Item 14) and two M8 (Item 15) upper crankcase bolts.

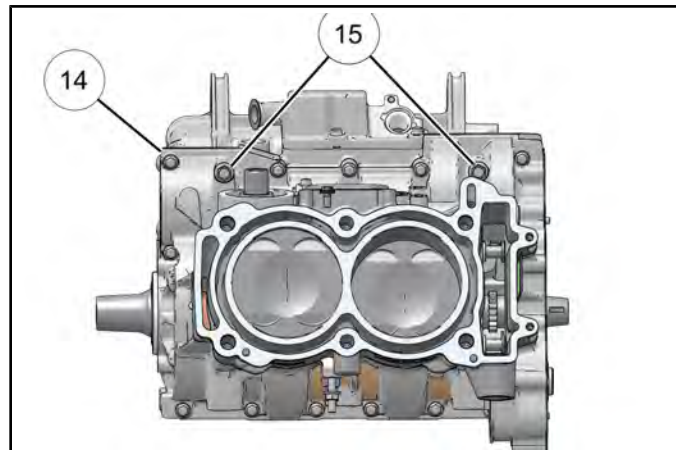

15. Rotate the engine so the cylinder is facing down.

16. Remove the eight M10 (Item 17) , two M8 (Item 18) and one M6 (Item 16) lower crankcase bolts. Discard the eight M10 bolts.

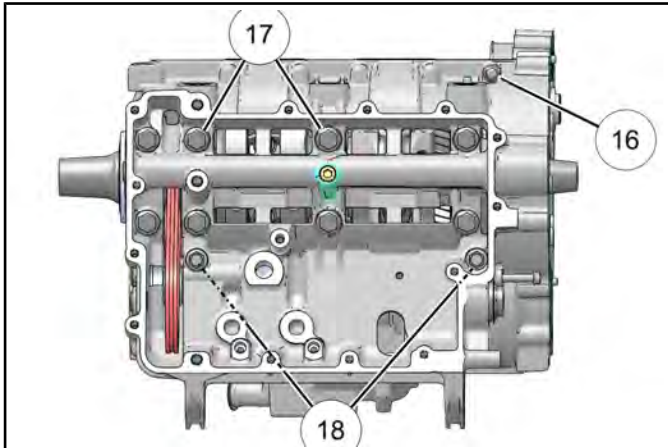

2. Note timing marks on balance shaft and crankshaft drive gears. Shafts must be properly timed upon assembly.

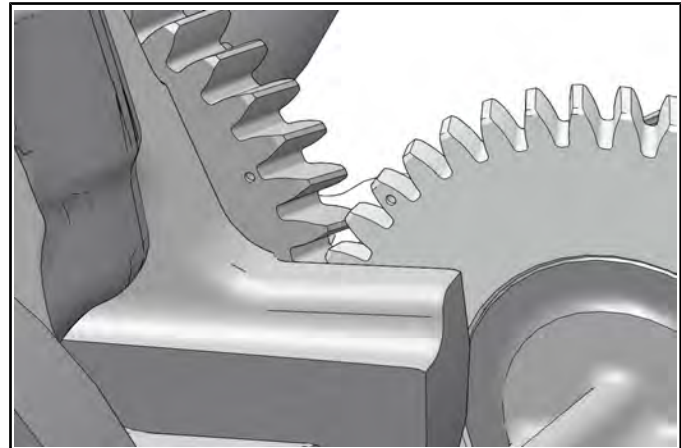

17. Tap on the lower crankcase in reinforced areas with a soft faced hammer to loosen. Carefully lift up and remove the lower crankcase half.

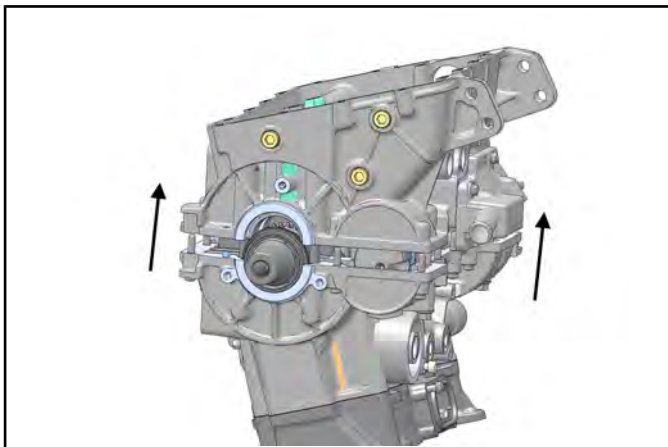

3. Carefully rotate the balance shaft (Item 2) and remove it from the crankcase.

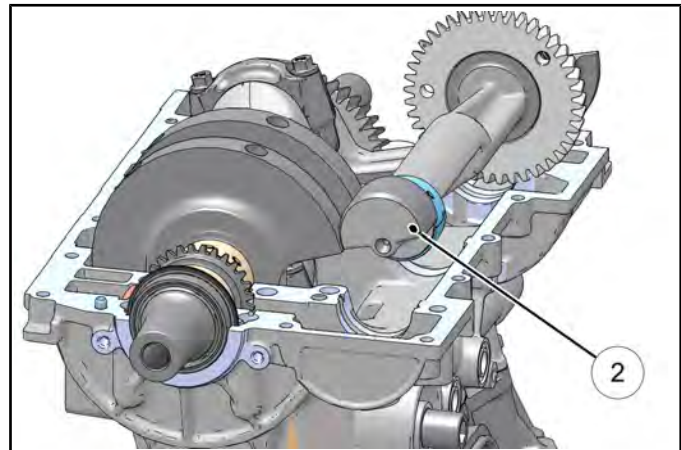

4. Inspect the balance shaft gear teeth for damage.

## Balance Shaft Removal / Inspection

1. Perform Crankcase Disassembly / Inspection, page 3.46 procedure.

# ENGINE

5. Measure each bearing journal in two locations, 90 degrees apart. Replace balance shaft if either journal is worn below the service limit specification. If worn past the service limit, replace the balance shaft assembly.

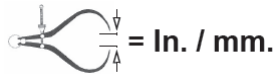
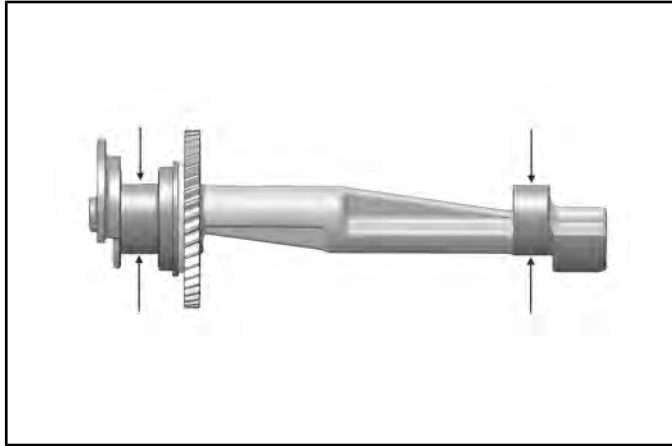

Balance Shaft Diameter (MAG & PTO)  
**1.4939 - 1.4946" (37.946 - 37.962 mm)**  
**Service Limit: 1.4921" (37.900 mm)**

## Crankshaft Removal / Inspection

1. Perform Crankcase Disassembly / Inspection, page 3.46 procedure.
2. Perform Balance Shaft Removal / Inspection, page 3.49 procedure.
3. For ease of assembly, mark each connecting rod and end cap.
4. Loosen, remove and discard the four connecting rod bolts (Item 1). Remove the end caps from the crankshaft.

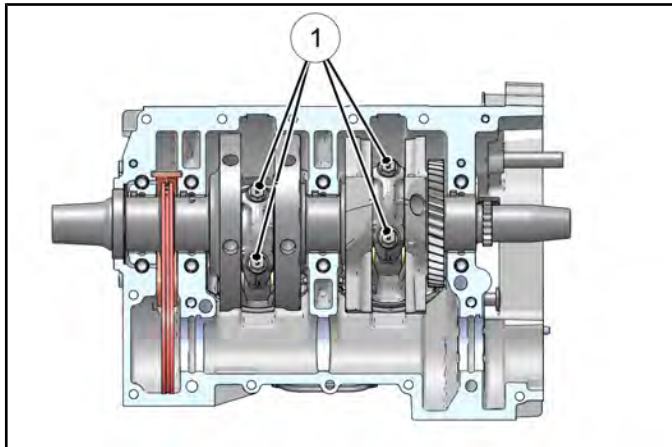

5. Carefully lift the crankshaft (Item 2) out of the crankcase.

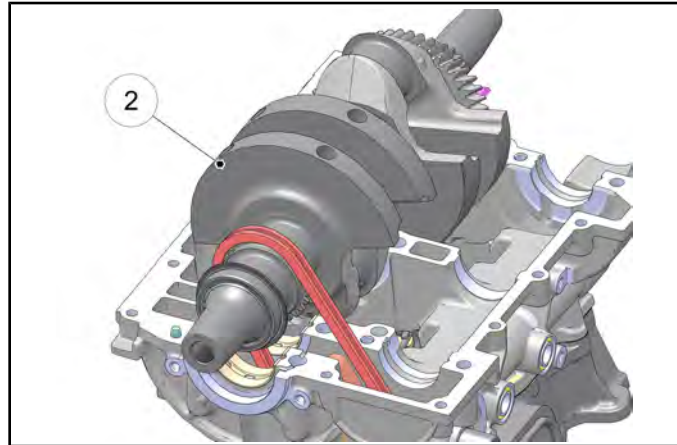

6. Remove the cam chain (Item 3), oil pump drive chain (Item 5) and PTO main seal (Item 4) from the crankshaft.

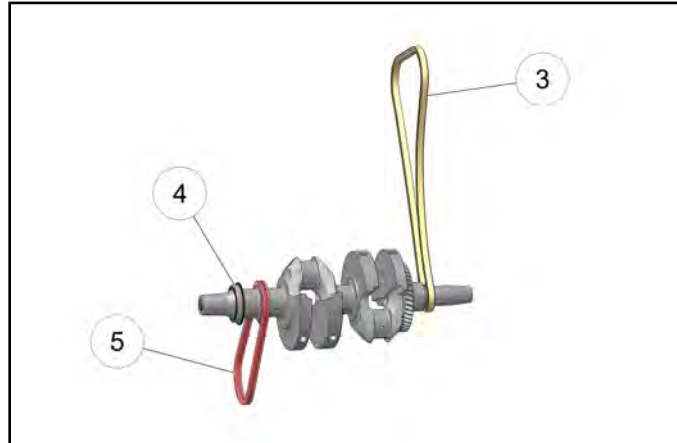

7. Inspect the crankshaft gear (Item 7) and auxiliary sprocket (Item 6) for broken or worn teeth.

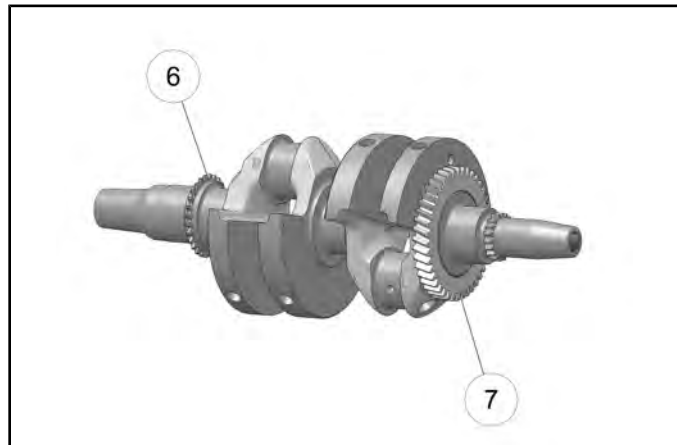

8. If the crankshaft gear or sprocket is damaged, the crankshaft assembly must be replaced.

9. Support crankshaft on V-blocks or on-centers in a crankshaft stand or lathe. Measure crankshaft run-out and replace if run-out exceeds maximum listed below.

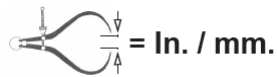
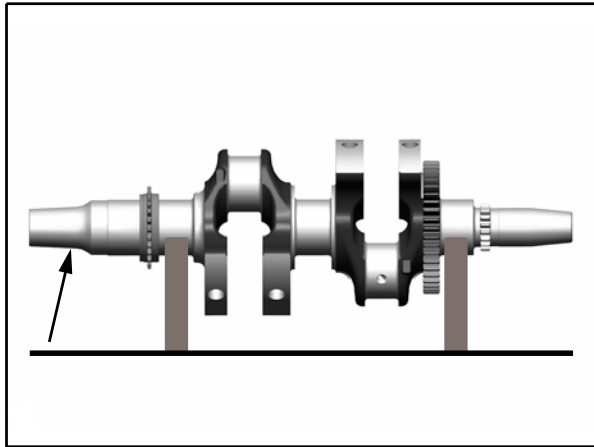

Crankshaft Maximum Runout:  
**Less than 0.001" (0.025 mm)**

10. Visually inspect surface of crankshaft main and connecting rod journals. Replace crankshaft if any journal is scratched or pitted.

11. Measure each main journal and connecting rod journal in two locations, 90 degrees apart. Replace crankshaft if any journal is worn below the service limit specification.

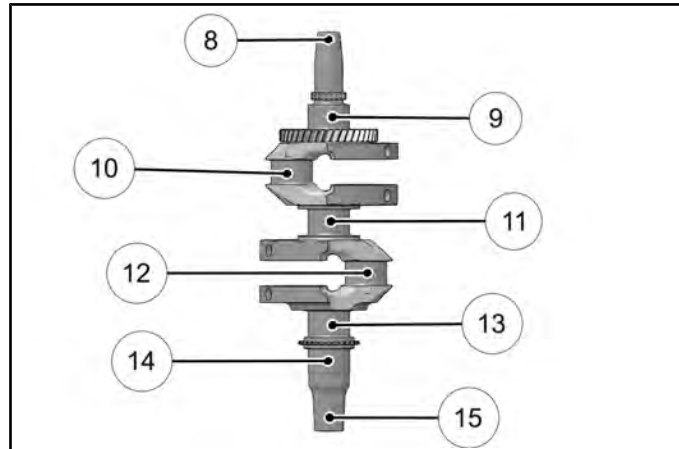

8. MAG End	12. Journal 4 (Rod Bearing)
9. Journal 1 (Main Bearing)	13. Journal 5 (Main Bearing)
10. Journal 2 (Rod Bearing)	14. Journal 6 (Main Bearing)
11. Journal 3 (Main Bearing)	15. PTO End

12. Refer to the six letters stamped onto the PTO end of the crankshaft.

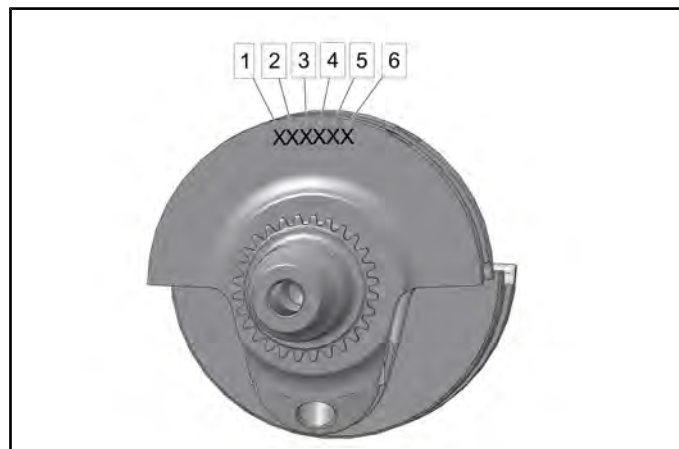



# ENGINE

13. Use the table below to see if the crankshaft bearing journals are within specification. If worn past the service limit, replace the crankshaft assembly.

<b>CRANKSHAFT BEARING JOURNAL DIAMETERS</b>		
<b>B</b>		
Main Bearing	Standard	<b>1.6140 - 1.6143"</b> <b>(40.996 - 41.004 mm)</b>
	Service Limit	<b>1.6129" (40.970 mm)</b>
Conn Rod Bearing	Standard	<b>1.6118 - 1.6122"</b> <b>(40.942 - 40.950 mm)</b>
	Service Limit	<b>1.6104" (40.906 mm)</b>
<b>G</b>		
Main Bearing	Standard	<b>1.6137 - 1.6140"</b> <b>(40.988 - 40.995 mm)</b>
	Service Limit	<b>1.6129" (40.970 mm)</b>
Conn Rod Bearing	Standard	<b>1.6115 - 1.6118"</b> <b>(40.934 - 40.941 mm)</b>
	Service Limit	<b>1.6104" (40.906 mm)</b>
<b>Y</b>		
Main Bearing	Standard	<b>1.6134 - 1.6137"</b> <b>(40.980 - 40.987 mm)</b>
	Service Limit	<b>1.6129" (40.970 mm)</b>
Conn Rod Bearing	Standard	<b>1.6112 - 1.6115"</b> <b>(40.926 - 40.933 mm)</b>
	Service Limit	<b>1.6104" (40.906 mm)</b>

14. Whether installing a new crankshaft or re-installing the original, refer to the bearing selection chart provided in the "Crankshaft Main Bearing Selection" and "Connecting Rod Bearing Selection" procedures.

## Crankcase Inspection

1. Remove the oil drain diverter (Item 1) from the upper crankcase.

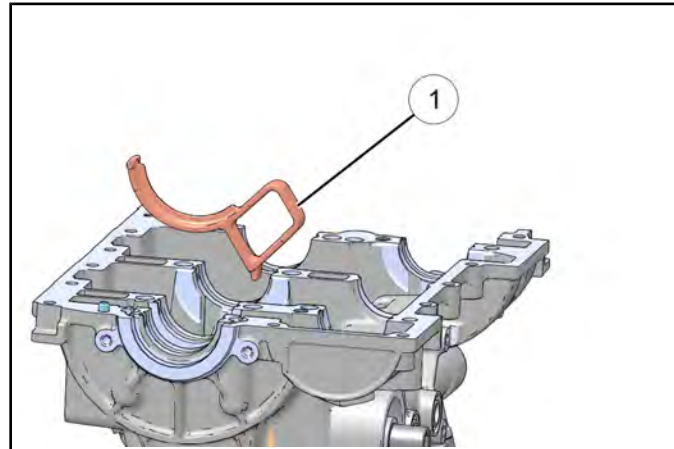

2. Remove all traces of crankcase sealer from the crankcase mating surfaces. Inspect the surfaces closely for nicks, burrs or damage.
3. Be sure alignment pins are in place where used.
4. Be sure oil passages are clean and free of any cleaning solvent (see "Engine Oil Flow Chart").

- Remove and discard the plain bearings located in the upper crankcase (Item 2), lower crankcase (Item 3) and connecting rods (Item 4). Replace the crankcase assembly if a bearing bore is galled or if bearing inserts have rotated in the case. Refer to bearing selection procedures upon assembly.

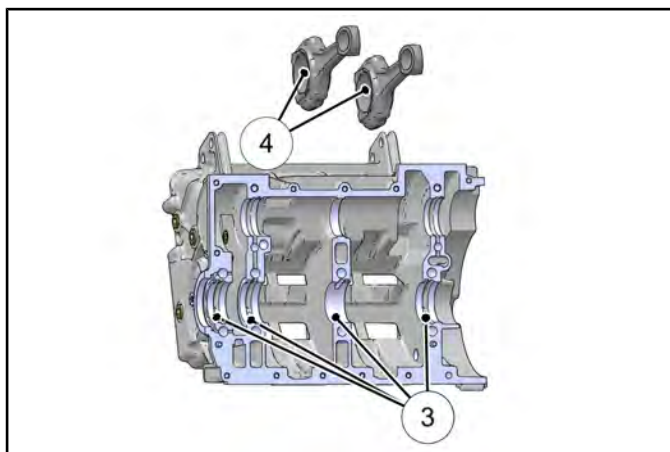
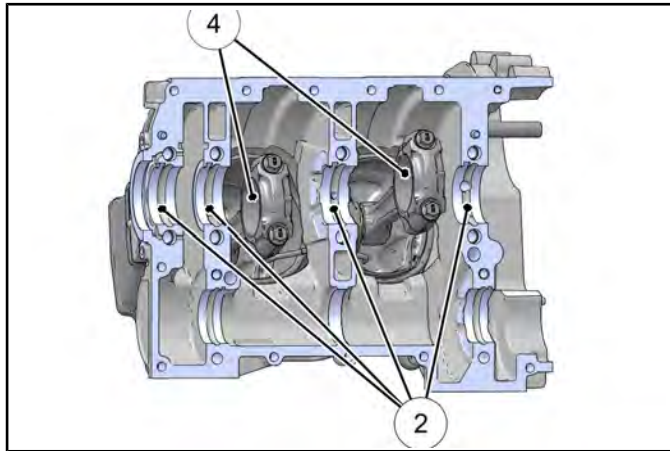

**NOTE:** Always replace plain bearings when the crankcase or connecting rods have been disassembled. Refer to Bearing Selection Identification Letters and Numbers, page 3.60.

## Cylinder Inspection

- Lay a straight edge (Item 1) across the top surface of the cylinder at several different points and measure warp by inserting a feeler gauge between the straight edge and the cylinder surface. If warp exceeds the service limit, replace the cylinder.

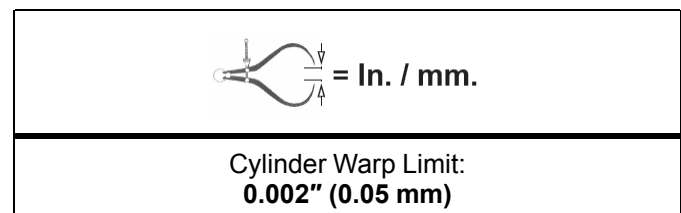
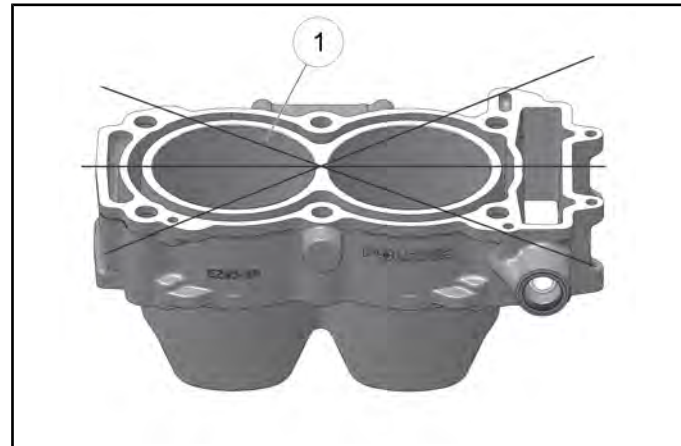

- Inspect cylinder for wear, scratches, or damage.

**NOTE:** DO NOT hone the cylinders or attempt to repair a damaged cylinder by honing.

3

# ENGINE

- Inspect cylinder for taper and out of round with a dial bore gauge. Measure in two different directions (front to back and side to side), on three levels (0.59 in. down from top, the middle, and 1.54 in. up from bottom). Record measurements. If cylinder is tapered or out of round beyond 0.001", the cylinder must be replaced.

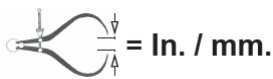
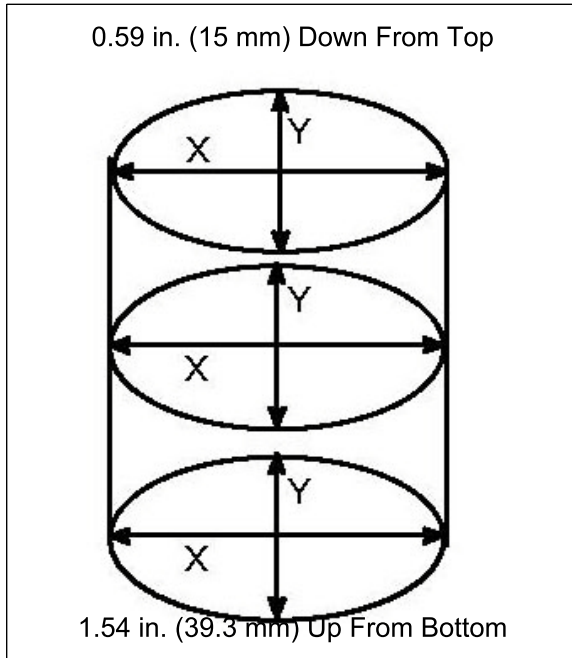

Cylinder Taper:  
**0.001" (0.025 mm)**

Cylinder Out of Round:  
**0.001" (0.025 mm)**

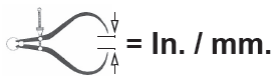

Standard Bore Size:  
**3.6614 ± 0.0003" (93 mm ± 0.008 mm)**

## Cylinder / Piston Removal

### CAUTION

Pistons must be removed from the cylinders with the connecting rods attached.  
DO NOT attempt to service the cylinder or pistons without disassembling the crankcase. Although you can remove the cylinder and pistons without disassembly, you will not be able to reassemble the engine because of the unique cylinder skirt and crankcase design.

- Perform ENGINE DISASSEMBLY / INSPECTION - TOP END, page 3.33 and the ENGINE DISASSEMBLY / INSPECTION - LOWER END, page 3.43 procedures.
- Rotate the engine so the cylinder is facing up.
- Remove the Cylinder Holding & Camshaft Timing Plate (PU-50563) (Item 1) from the cylinder.

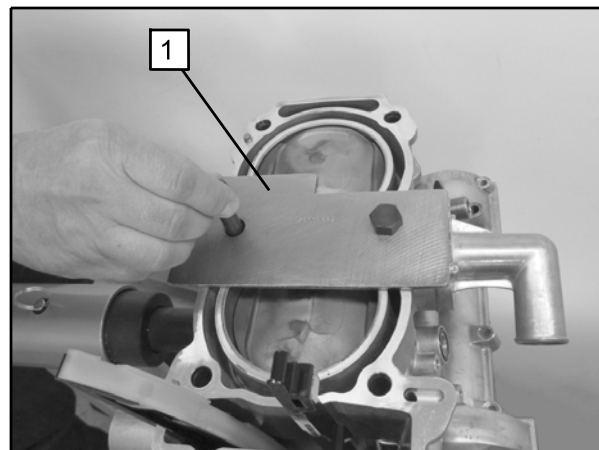

- Carefully lift the cylinder and pistons from the upper crankcase.

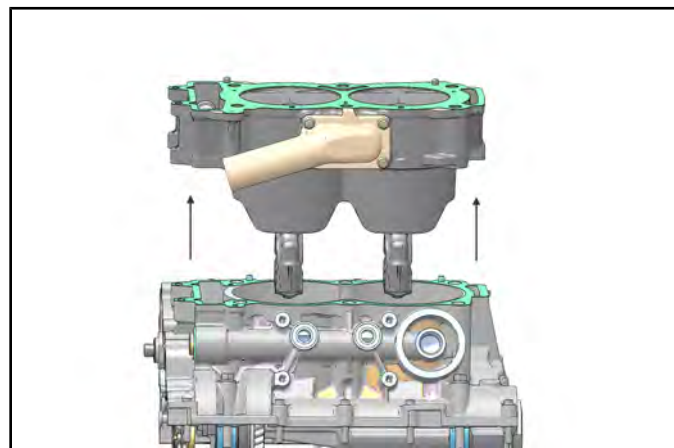

- Remove the piston / connecting rod assemblies from the cylinder.



**NOTE:** If the pistons are to be reused, mark the pistons so they are reassembled in the same cylinder bore and direction from which they were removed (MAG / PTO).

## Piston Disassembly / Inspection

**NOTE:** New pistons are directional (intake vs. exhaust), but can be placed in either cylinder.

- Note location of the piston circlip gap (Item 1) at the top (12:00 position) or bottom (6:00 position).

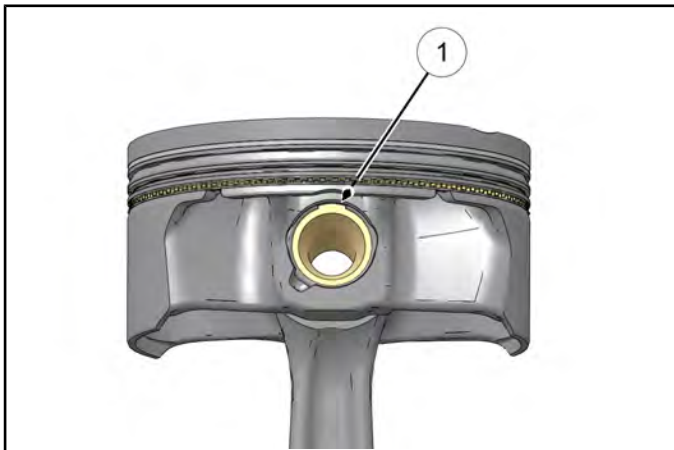

- Remove piston circlip and push piston pin out of piston. If necessary, heat the crown of the piston slightly with a heat gun if pin cannot be removed by hand. Discard circlips.

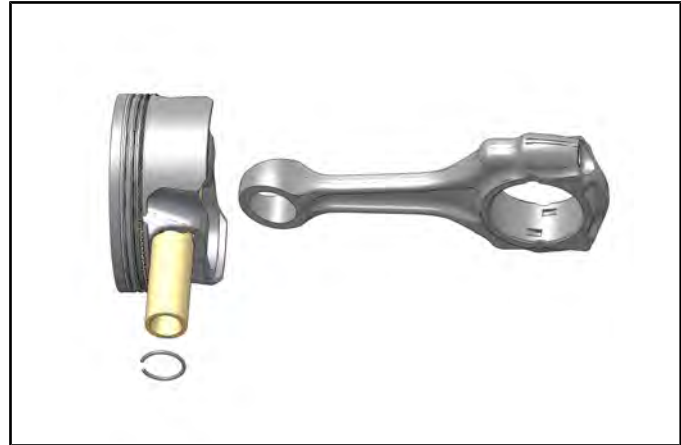

**CAUTION**

DO NOT apply heat to piston rings or a loss of radial tension could result.

- Measure piston pin bore I.D. in two directions (90° apart). Replace piston and piston pin if out of specification.

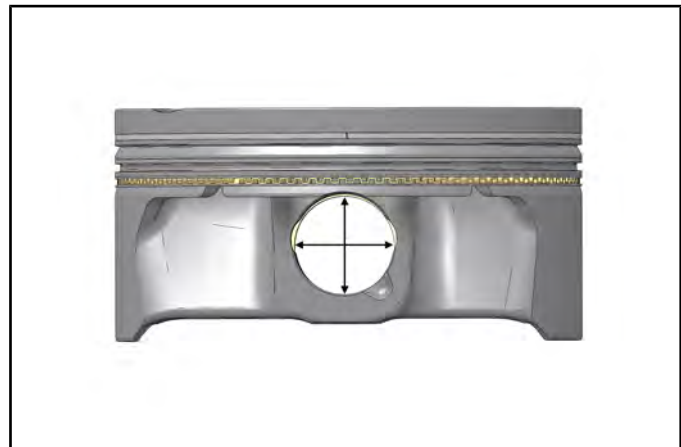

= In. / mm.

Piston Pin Bore I.D.:  
**0.7877 - 0.7881" (20.009 - 20.018 mm)**  
**Service Limit: 0.7893" (20.05 mm)**

# ENGINE

4. Measure piston pin O.D. in two directions (90° apart) at three locations on the length. Replace piston and piston pin if out of specification.

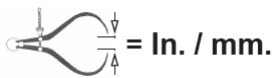
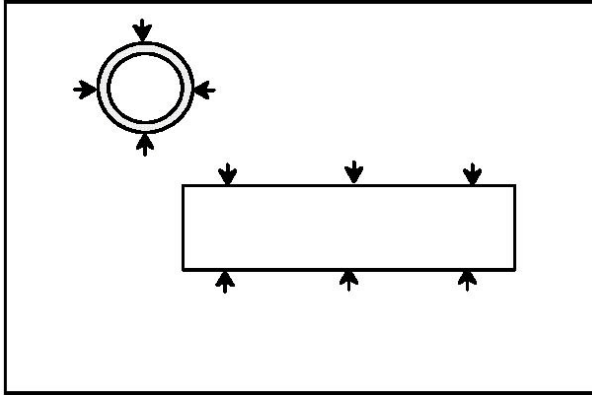

Piston Pin O.D.:  
**0.7873 - 0.7875" (20.000 - 20.005 mm)**  
**Service Limit: 0.7866" (19.98 mm)**

## Piston Ring Removal

1. Carefully remove top compression ring (Item 1) by hand or using a ring removal pliers.

### CAUTION

DO NOT expand the ring more than necessary to remove it from the piston or the ring may break or lose radial tension.

- **Piston ring pliers:** Carefully expand ring and lift it off the piston.
- **By hand:** Placing both thumbs on the ring ends, spread the ring open and push up on opposite side. Do not scratch ring lands.

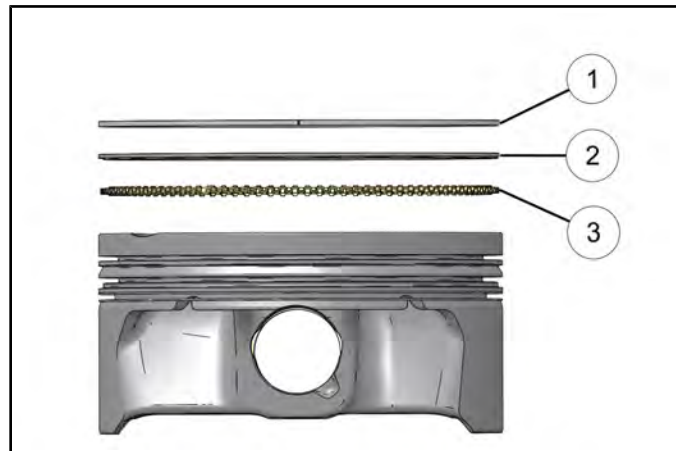

2. Repeat procedure for second compression ring (Item 2).
3. The oil control ring (Item 3) is a three piece design consisting of a top and bottom steel rail and a center expander section. Remove top rail first, then bottom rail, then the expander.

## Piston Ring to Groove Clearance Inspection

1. Measure piston ring to groove clearance (Item 1) by placing the ring in the ring land and measuring with a thickness (feeler) gauge. Replace piston and rings if ring-to-groove clearance exceeds service limits.

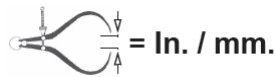
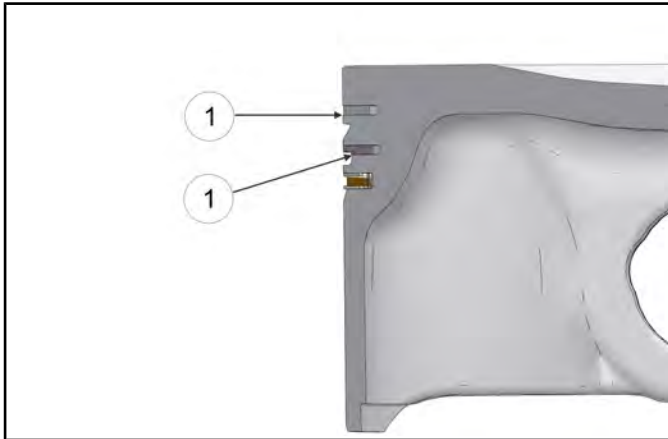

Piston Ring to Groove Clearance:  
Top / Second Ring:  
**0.0007 - 0.0023" (0.020 - 0.060 mm)**  
Service Limit: **0.0047" (0.12 mm)**

## Piston Ring Installed Gap

1. Place each piston ring (Item 1) inside the cylinder (Item 2). Use the piston to push the ring squarely into the cylinder, as shown below.
2. Measure installed gap with a feeler gauge (Item 3) at both the top and bottom of the cylinder.

**NOTE: A difference between top and bottom end gap measurements is a general indication of cylinder taper (wear). The cylinder should be measured for taper and out of round.**

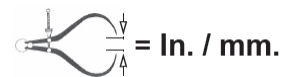
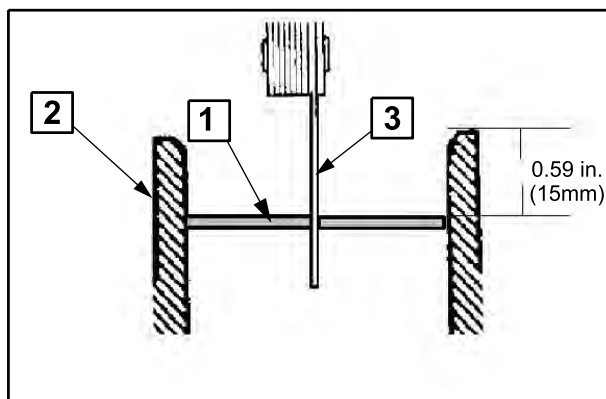

Piston O.D. (Standard):  
**3.6597 ± 0.0003" (92.959 ± 0.008 mm)**

3. If the installed gap measurement exceeds the service limit, replace the rings.

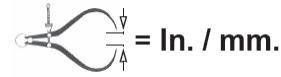

Piston Ring Installed Gap:  
**Top Ring: 0.010 - 0.014" (0.25 - 0.35 mm)**  
Service Limit: **1.6118 - 1.6122" (40.942 - 40.950 mm)**  
**Second Ring: 1.6118 - 1.6122" (40.942 - 40.950 mm)**  
Service Limit: **0.028" (0.70 mm)**  
**Oil Control Rails: 0.008 - 0.028" (0.20 - 0.70 mm)**  
Service Limit: **0.0354" (0.9 mm)**

**NOTE: Always check piston ring installed gap when installing new rings and/or a new cylinder.**

## Piston-to-Cylinder Clearance

Measure piston outside diameter at a point 10 mm (Item 1) up from the bottom of the piston, at a right angle to piston pin bore.

Subtract measurement from maximum measurement obtained in Step 4 of Cylinder Inspection, page 3.53 "Cylinder Inspection" procedure.

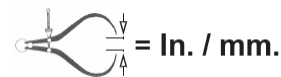
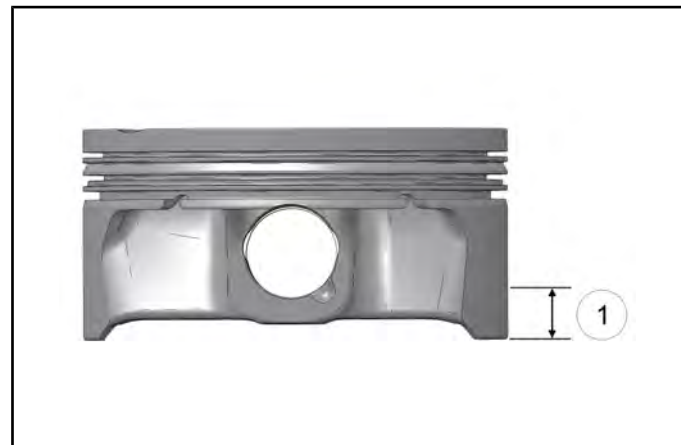

Piston O.D. (Standard):  
**3.6597 ± 0.0003" (92.959 ± 0.008 mm)**

# ENGINE

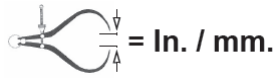

Piston to Cylinder Clearance:  
**0.0009 - 0.0019" (0.025 - 0.050 mm)**

## Connecting Rod Inspection

1. The 5 digit numbers stamped onto the intake side of the connecting rod are serial numbers used to match the rod stem with the rod cap.

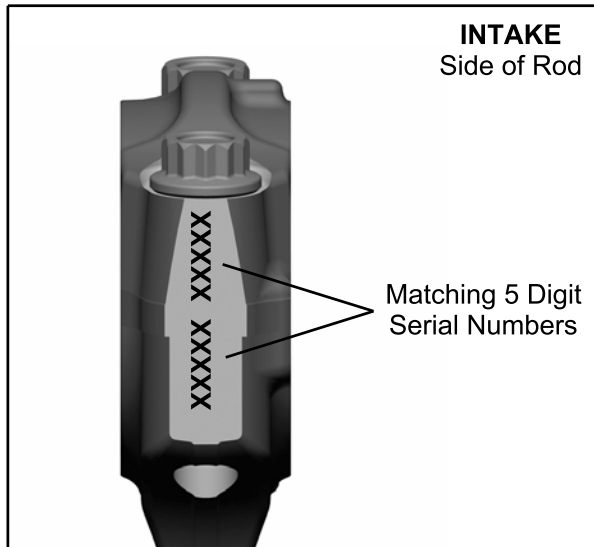

2. The number and letter stamped onto the exhaust side of the connecting rod represent the bore diameter and weight grading of the connecting rod.

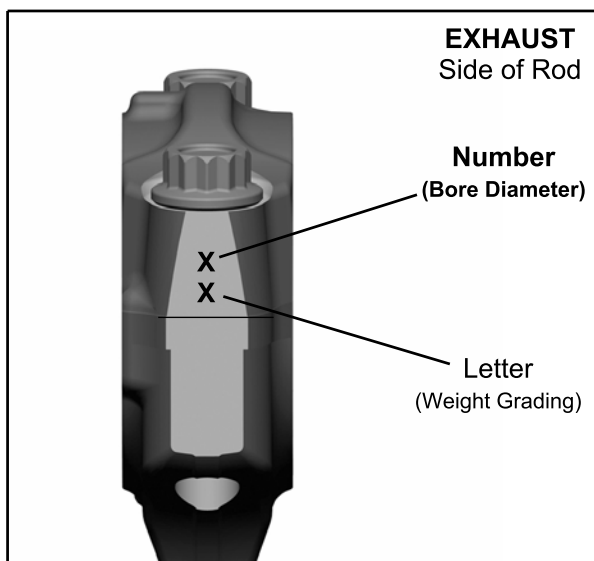

3. Inspect the small end and big end of connecting rod (and matching rod cap) for damage, galling of surface or pitting.
4. Measure small end I.D. in two directions as shown. Record measurements and compare to specifications. Replace connecting rod if worn past the service limit specification.

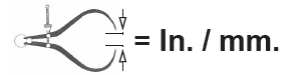
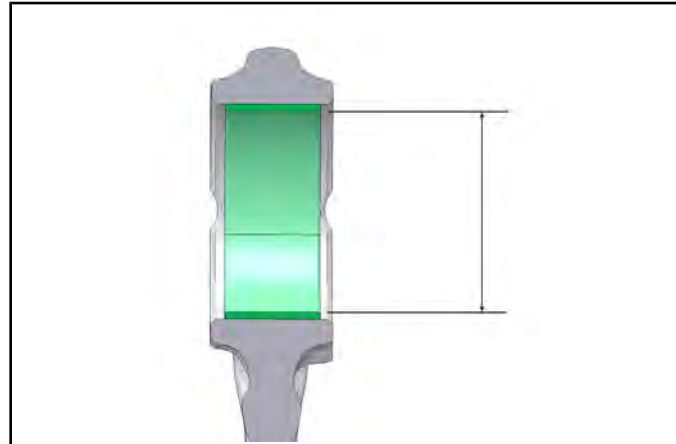

Connecting Rod Small End I.D.:  
**0.7879 - 0.7885" (20.015 - 20.030 mm)**  
**Service Limit: 0.7897" (20.06 mm)**

5. Install matching rod cap on connecting rod (**without bearings**) and install the bolts.
6. Tighten bolts snug, then torque to 13 ft-lbs (18 Nm).
7. Using a dial bore gauge, measure big end I.D. in two directions shown. Record measurements and compare to specifications.

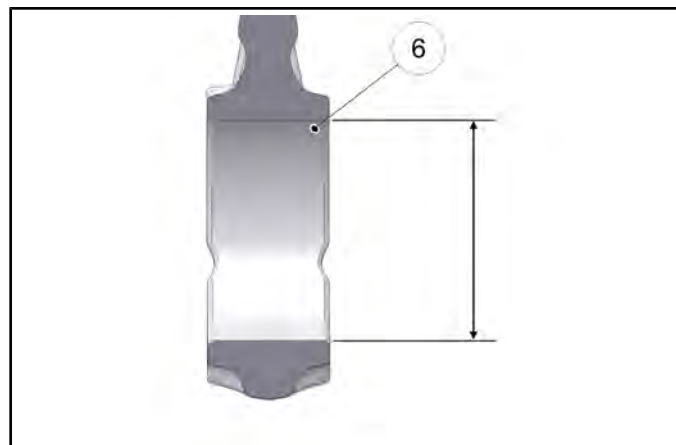

- Refer to the number stamped onto the exhaust side of the connecting rod. This number represents the bore diameter.

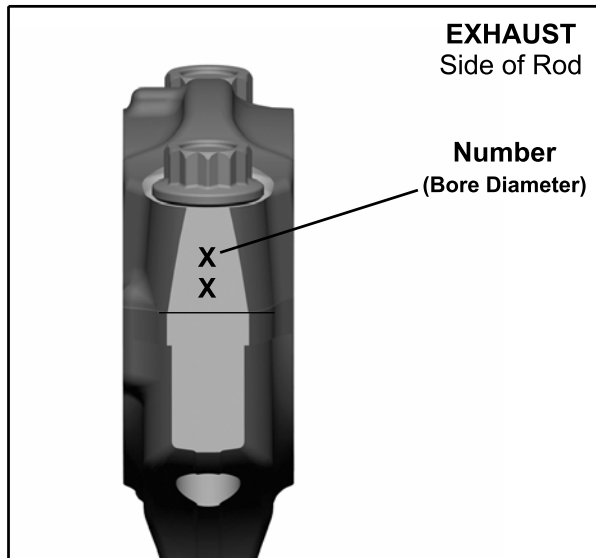

**3**

- The table below lists the big end bore diameter specifications.

**Bearing Selection Chart — Rod Bearings**

CONNECTING ROD BIG END BORE DIAMETERS		
1	2	3
1.7318 - 1.7321" (43.989 - 43.996 mm)	1.7321 - 1.7323" (43.996 - 44.003 mm)	1.7323 - 1.7326" (44.003 - 44.010 mm)

- Whether using new connecting rods or re-installing the original ones, refer to the bearing selection chart provided in the Connecting Rod Bearing Selection, page 3.61 procedure.



# ENGINE

## ENGINE ASSEMBLY - LOWER END

### Bearing Selection Identification Letters and Numbers

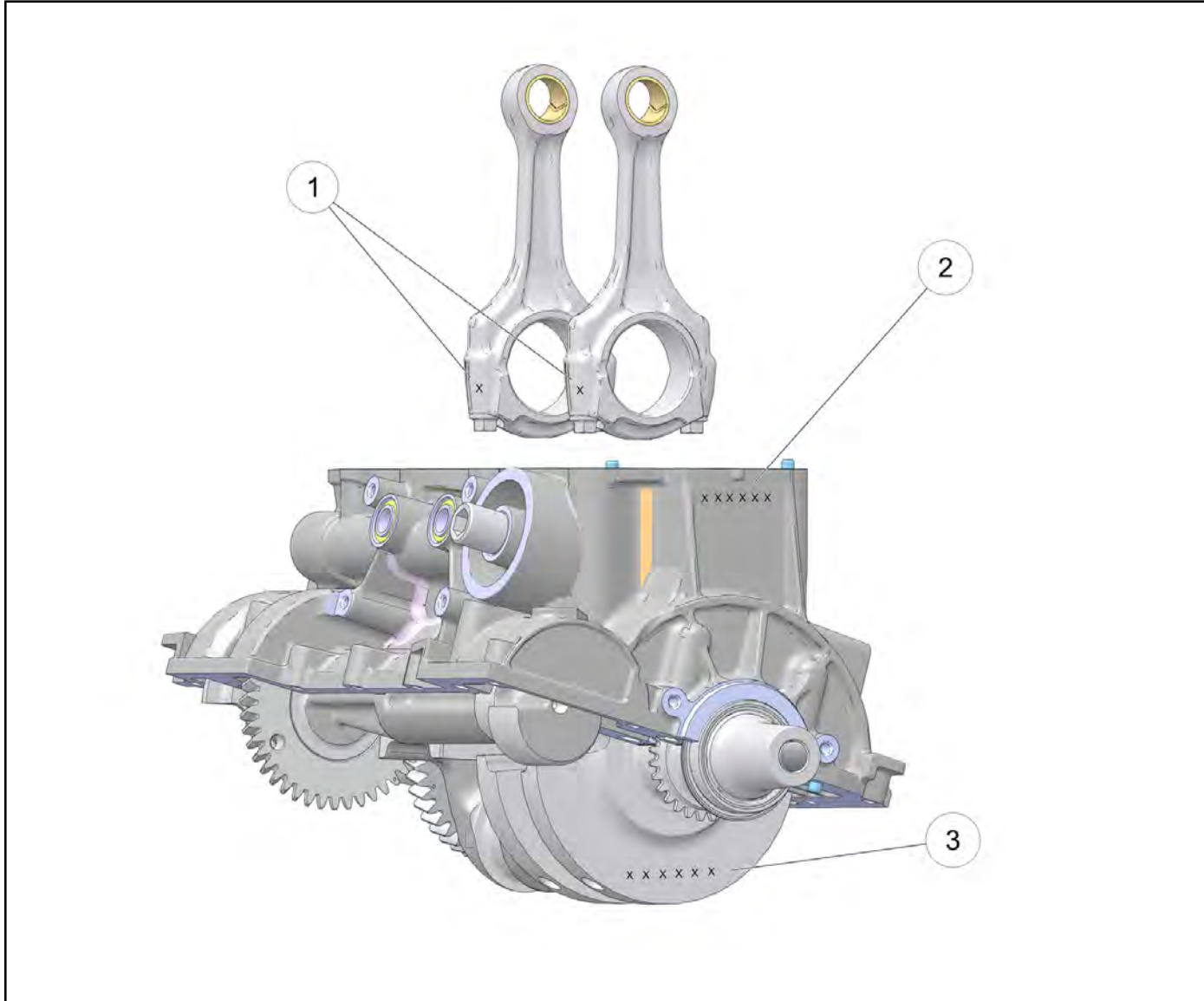

1. Connecting Rod Bearing Identification Number (1-number)	2. Crankcase Bearing Identification Number (6-numbers)	3. Crankshaft Bearing Identification Letters (6-Letters)
--	--	--

## Connecting Rod Bearing Selection

In order to select the proper bearing for the connecting rods, you must reference the number on each connecting rod (Item 7 & 8) and match that up with the rod journal letters on the crankshaft (Item 9).

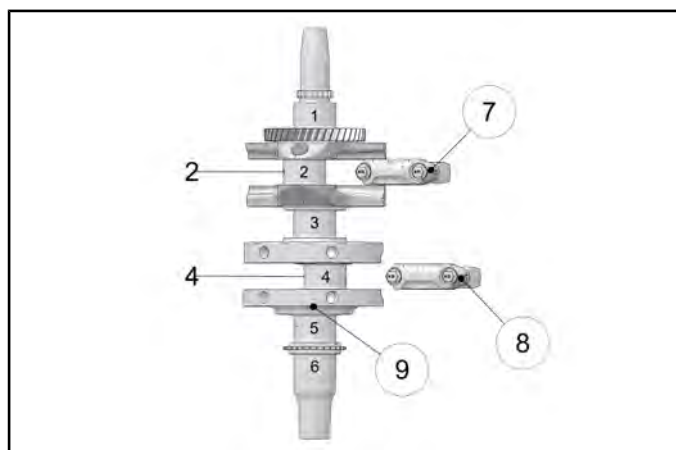

In this example, you would use the number 2 as the connecting rod code. You would use letters G and G as the crankshaft codes (crank journals 2 and 4). Based off the bearing selection chart, you would use a *Green* bearing for each connecting rod

**Bearing Selection Chart — Rod**

	Crankshaft			
	Code	B	G	Y
Rod	1	Blue	Blue	Green
	2	Blue	Green	Yellow
	3	Green	Yellow	Yellow

## Crankshaft Main Bearing Selection

In order to select the proper main bearings for the crankshaft, you must reference the six numbers on the crankcase (Item 8) and match that up with the main journal letters on the crankshaft (Item 7).

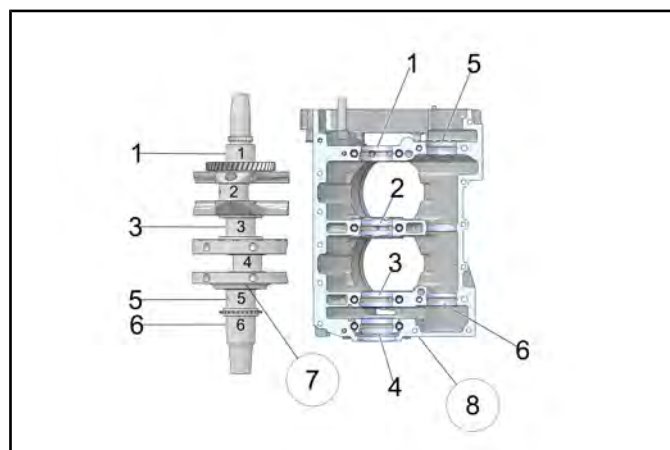

In this example, you would use the number 2 as the crankcase codes (case journals 1, 2, 3, 4). You would use letters G, Y, G, Y as the crankshaft codes (crank journals 1, 3, 5 and 6). Based off the bearing selection chart, you would use:

*Green* bearing for Main #1

*Yellow* bearing for Main #2

*Green* bearing for Main #3

*Yellow* bearing for Main #4

**Bearing Selection Chart — Main Bearings**

	Crankshaft			
	Code	B	G	Y
Case	1	Blue	Blue	Green
	2	Blue	Green	Yellow
	3	Green	Yellow	Yellow

## Upper Crankcase Preparation

**NOTE:** Always replace plain bearings when the crankcase or connecting rods have been disassembled. Refer to bearing selection procedures.

1. Remove all traces of crankcase sealer from the crankcase mating surfaces. Inspect the surfaces closely for nicks, burrs or damage.
2. Clean bolt hole threads to remove any oil or crankcase sealant.

# ENGINE

3. Inspect crankcase bearing bores. Replace the crankcase assembly if a bearing bore is galled or if bearing inserts have rotated in the case.
4. Be sure alignment pins are in place where used.
5. Refer to "Oil Flow Chart" at the beginning of this chapter and trace the oil paths through the crankcase and cylinder.
6. Flush all oil passages with solvent and then warm soapy water. Rinse with clear, warm water and dry with compressed air.
7. Be sure passages are clean and dry before assembling the upper crankcase.

## Piston Ring Installation

**NOTE: Apply clean engine oil to all ring surfaces and ring lands upon installation. Always check piston ring installed gap before rings are installed on piston (see "Piston Ring Installed Gap"). Clean accumulated carbon from piston ring grooves and oil ring lube holes if piston has been in service.**

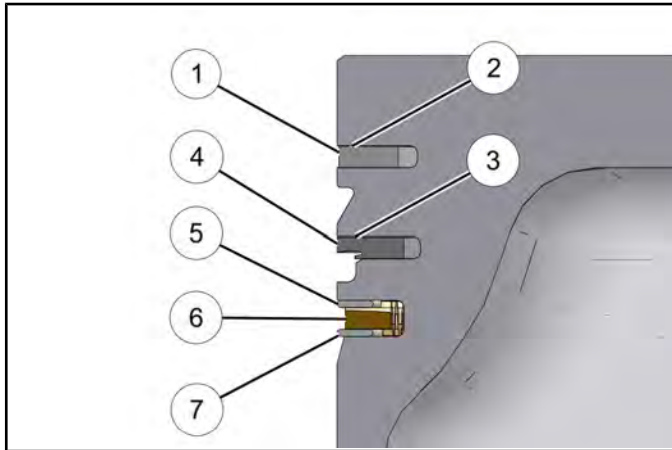

1. Top Ring	5. Upper Rail
2. Marking Up	6. Spring Expander
3. Marking Up	7. Lower Rail
4. Second Ring	

1. Place oil control ring expander in oil ring groove. Rotate expander in groove until butt ends are on PTO side of piston (see illustration below).

**NOTE: Ends must butt squarely together and must not overlap.**

2. Install lower rail with end gap positioned on the intake side of piston.

3. Install upper rail with end gap positioned on the exhaust side of piston.

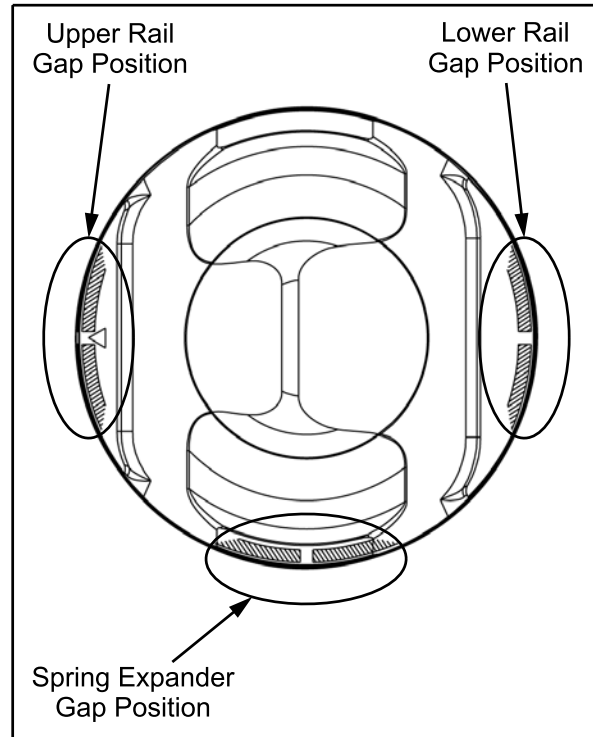

4. Install second ring with marking facing top of piston. Rotate ring to position the end gap toward intake side of piston as shown below.

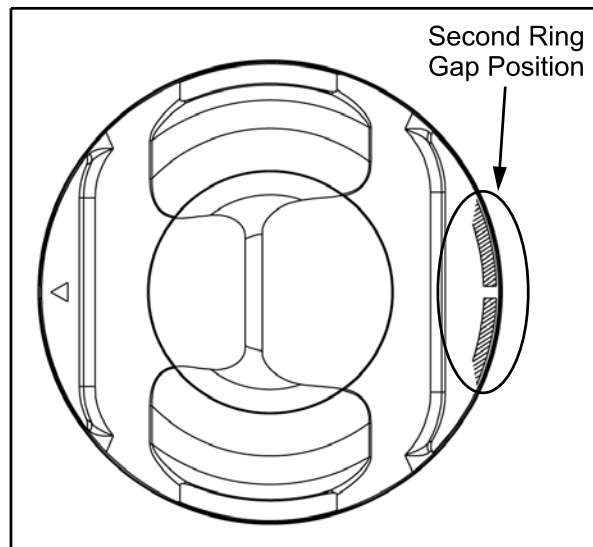

5. Install top ring with mark facing top of piston. Rotate ring to position the end gap toward exhaust side of piston as shown below.

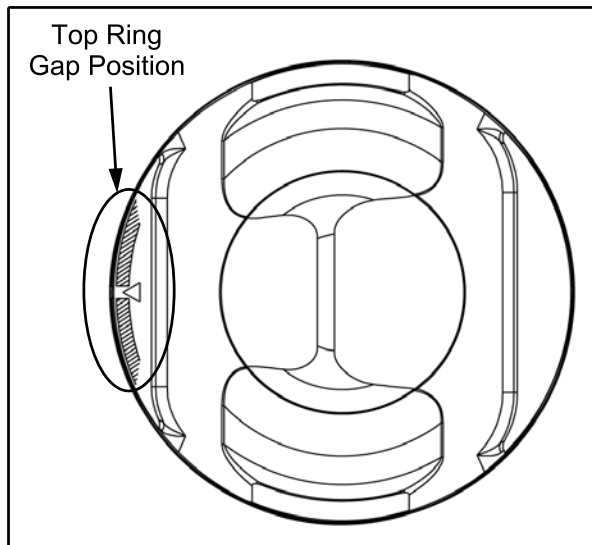

6. Be sure top and second rings rotate freely in their grooves and do not bind when compressed by hand.

### Piston / Connecting Rod Assembly

1. Lubricate connecting rod small end, piston pin bore and piston pin with engine oil.

#### CAUTION

Do not re-use circlips. Circlips become deformed during the removal process.  
Do not compress the new clip more than necessary to prevent loss of radial tension. Severe engine damage may result if circlips are re-used or deformed during installation.

2. Install a new circlip on one side of piston with gap at the top (12:00 position) or bottom (6:00 position).



**NOTE:** Never re-use a piston pin circlip.

If reinstalling the original connecting rods, orientate the rods the same as when removed. If new connecting rods are being installed, they can be installed either way (there is no piston pin offset in the rod), however it is recommended they be installed with rods facing the same direction.

3. Place piston (Item 1) on connecting rod (Item 2). Push piston pin (Item 3) through rod and piston until it seats against the installed circlip.

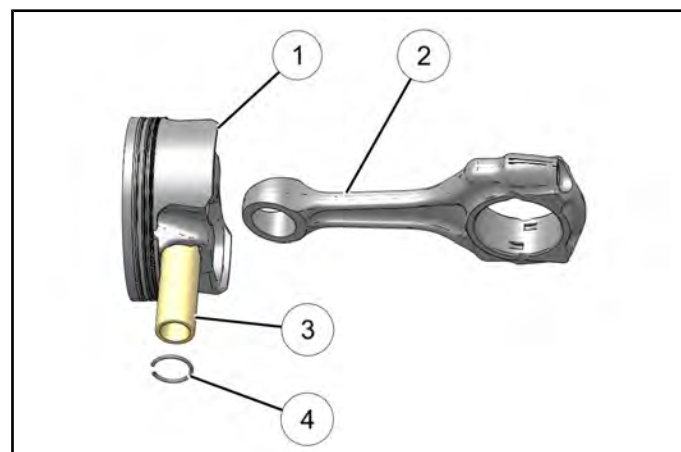

**NOTE:** Do not tap on pin or cause any sideways force to connecting rod. Warm piston crown with a heat gun if pin cannot be installed by hand, or use a piston pin installation tool.

#### CAUTION

DO NOT apply heat to piston rings or a loss of radial tension could result.

# ENGINE

4. Install the remaining circlip (Item 4) with gap at the top (12:00 position) or bottom (6:00 position). Push the piston pin in both directions to make sure the clips are properly seated in the groove.

## Cylinder / Piston Installation

### CAUTION

Pistons must be installed into the cylinders with the connecting rods attached.  
DO NOT attempt to service the cylinder or pistons without disassembling the crankcase. Although you can remove the cylinder and pistons without disassembly, you will not be able to reassemble the engine because of the unique cylinder skirt and crankcase design.

**NOTE: If the pistons are being reused, reassemble in the same cylinder bore and direction from which they were removed (MAG / PTO).**

**New pistons are directional (intake vs. exhaust), but can be placed in either cylinder.**

1. Apply clean engine oil to each piston assembly, cylinder bore and bottom tapered portion of each cylinder sleeve.
2. Verify that all ring end gaps are correctly located on each piston (see "Piston Ring Installation").

3. Note the piston orientation mark (arrow) located on top of the piston. Arrow should point toward the exhaust side.

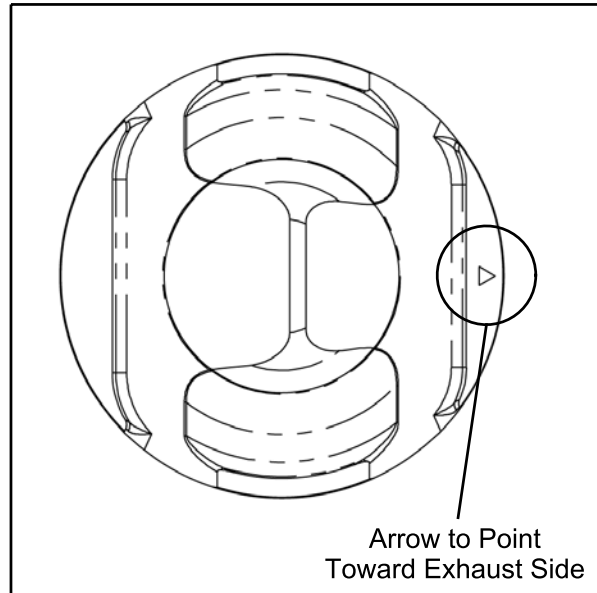

**NOTE: Orientation arrow is also located on the bottom side of piston as an additional reference.**

4. Carefully compress the piston rings with your fingers and install the piston / connecting rod assemblies into the cylinder from the bottom side.

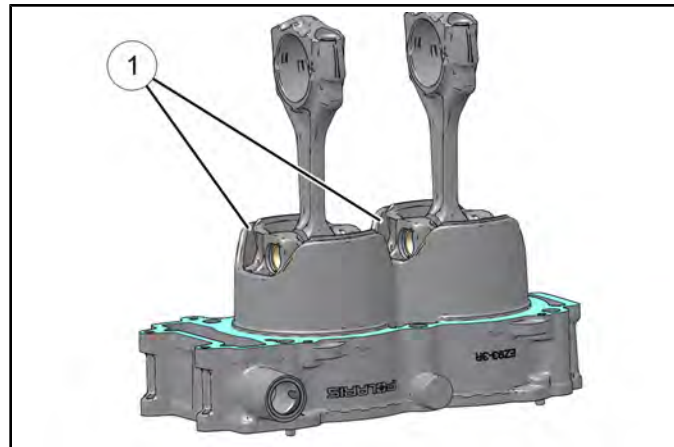

**NOTE: Use a slight front to back rocking motion until all rings are captive in cylinder and past the cylinder sleeve opening (Item 1).**

5. Rotate the engine so the crankcase to cylinder mounting surface is facing up.

6. Clean base gasket sealing surface on cylinder and crankcase to remove all oil and grease.

**NOTE: Base gasket and surfaces must be DRY and oil free. Use care upon assembly to keep oil away.**

7. Reinstall dowel pins in crankcase if previously removed.
8. Install a new cylinder base gasket.
9. Verify piston orientation (arrow pointing toward exhaust) one last time prior to installation.

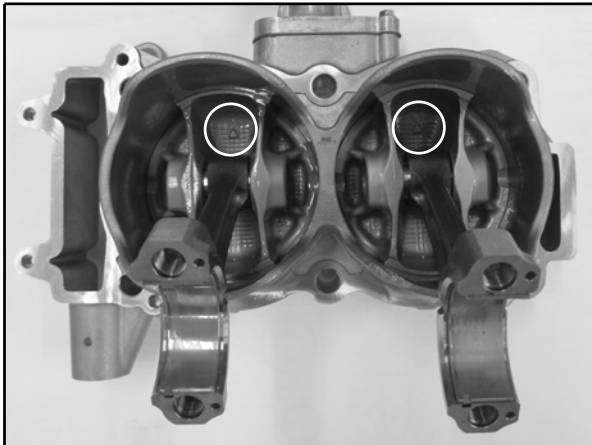

10. Carefully place the cylinder and pistons into the upper crankcase.

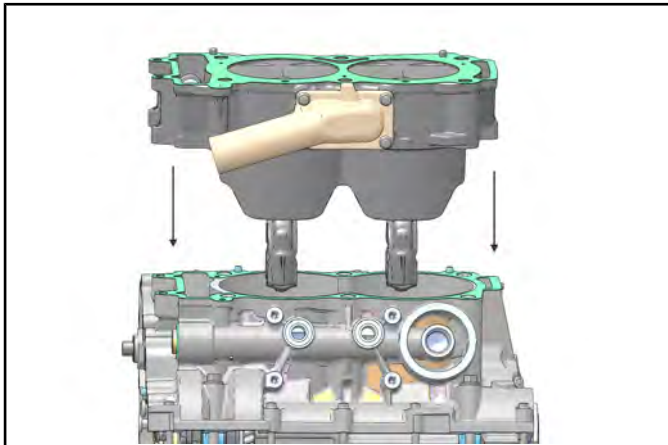

11. Install the Cylinder Holding & Camshaft Timing Plate (PU-50563) onto the cylinder. The cylinder holding tool retains the cylinder and pistons when the engine is rotated.

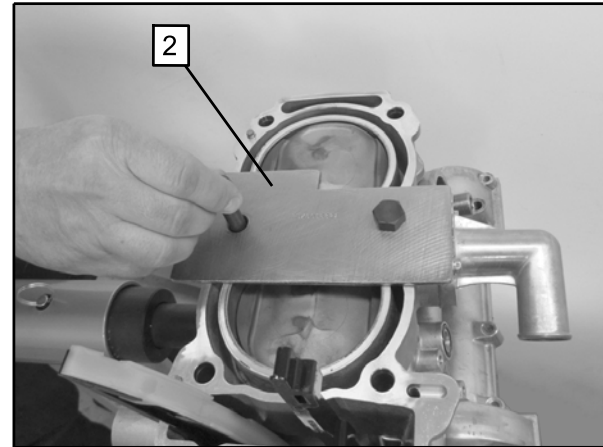

3

## Crankshaft Installation

**NOTE: Whether installing a new crankshaft or re-installing the original, refer to the bearing selection charts (see Crankshaft Main Bearing Selection, page 3.61 and Connecting Rod Bearing Selection, page 3.61 procedures in this chapter).**

1. Rotate the engine so the cylinder is facing down.
2. Clean the bearing bore surfaces of upper crankcase (main bearings), connecting rods and connecting rod caps.
3. Align tab of new main bearing (Item 1) with the slot in main bearing bore of crankcase. Press bearing insert firmly into place. Repeat for all main bearings.
4. Align tab of new connecting rod bearings (Item 2) with the slot in the connecting rod stem and connecting rod end cap. Press bearing insert firmly into place. Repeat for the other connecting rod.

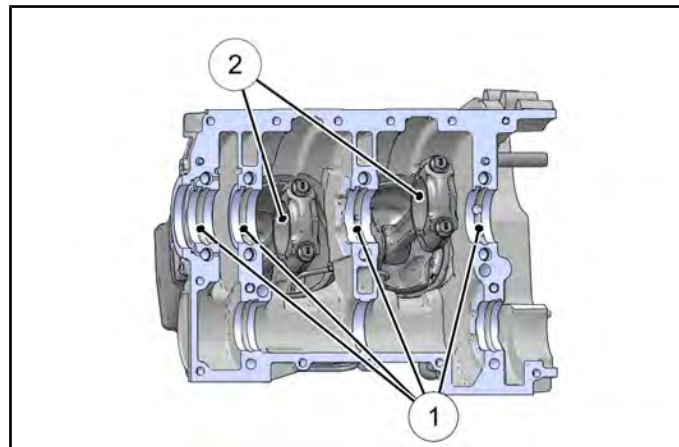

# ENGINE

5. Install oil drain diverter (Item 3) into the upper crankcase.

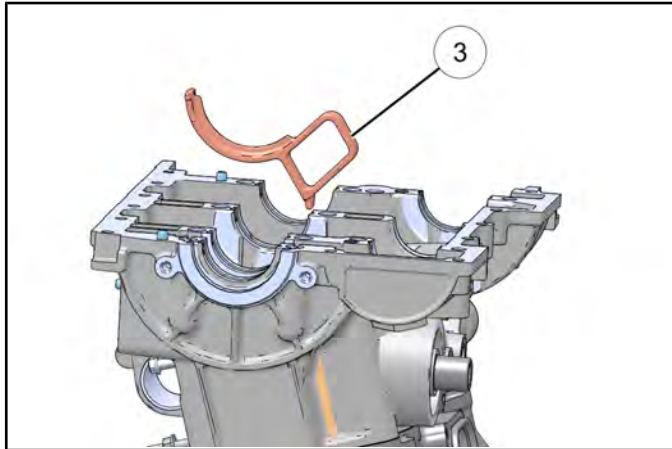

6. Apply Polaris PS-4 engine oil to each rod bearing journal (Item 4) and main bearing journal (Item 5) of crankshaft.

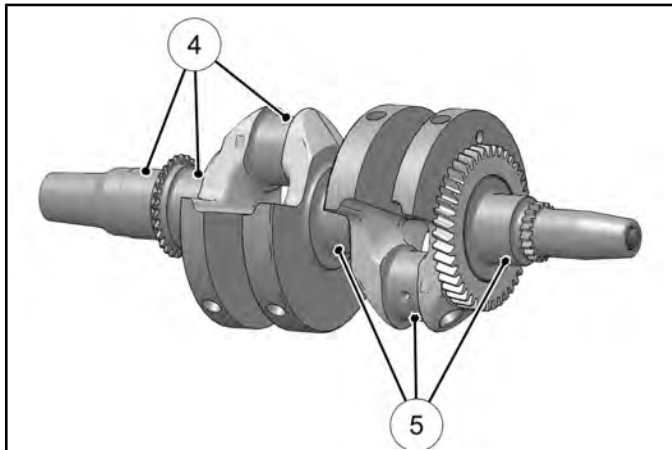

7. Loop cam chain (Item 6) and oil pump drive chain (Item 8) over crankshaft sprockets.
8. Apply Polaris PS-4 engine oil to the new crankshaft oil seal (Item 7) and install the seal on the PTO end of the crankshaft.

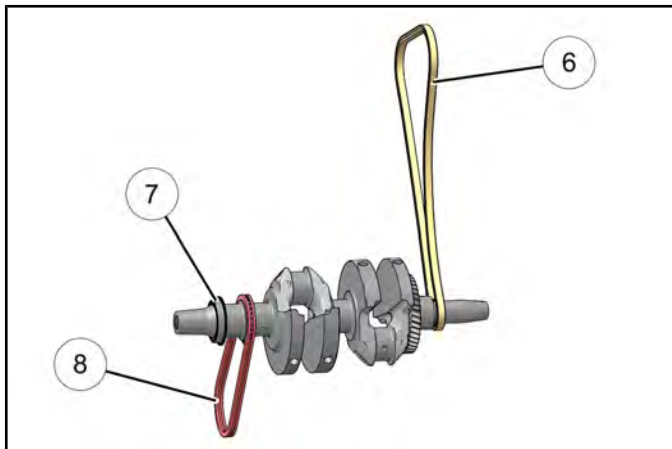

9. Carefully lower the crankshaft into upper crankcase. Guide connecting rods onto the rod journals of crankshaft as necessary.

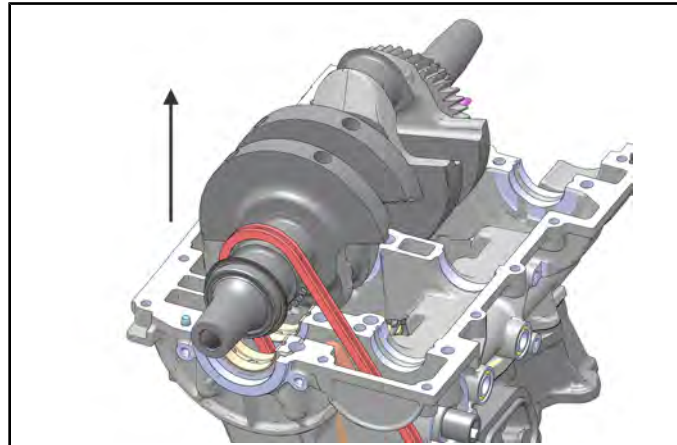

10. Adjust the PTO crankshaft seal so it rests properly in the upper crankcase.
11. Clean bolt hole threads in connecting rod to remove all oil.
12. Install matching rod cap on connecting rod with 5 digit serial number stampings aligned.

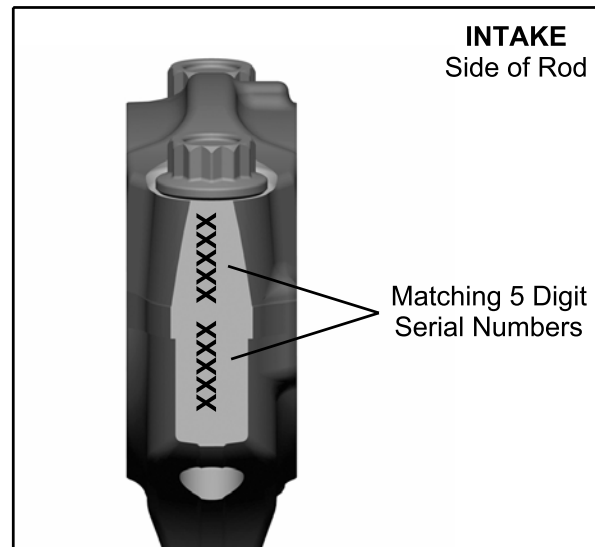

13. Install *new bolts* (Item 11) and tighten evenly until snug.

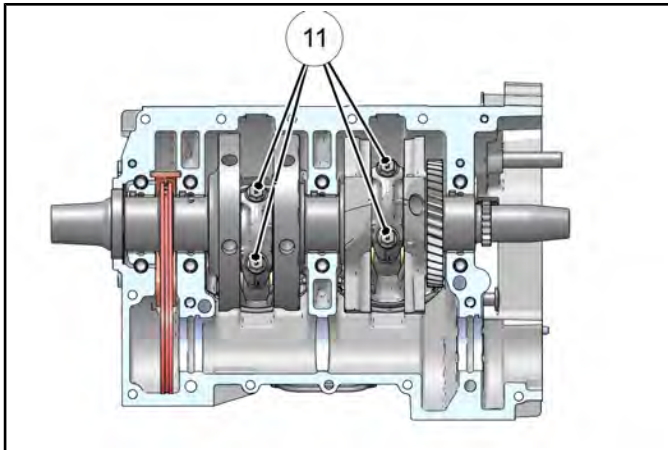

14. Torque connecting rod bolts to specification.



Connecting Rod Bolts:  
**Step 1: 9 ft-lbs (12 Nm)**  
**Step 2: 13 ft-lb (18 Nm)**  
**Step 3: Tighten add'n 105°**

## Balance Shaft Installation

1. Clean the upper crankcase balance shaft bearing bore surfaces.
2. Align tab of new balance shaft bearings (Item 1) with the slot in each bearing bore of crankcase. Press bearing insert firmly into place.

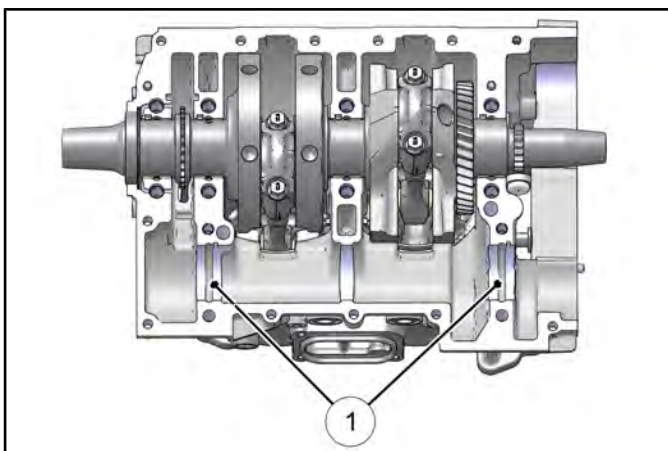

3. Rotate the crankshaft until the alignment dot (Item 3) on the crankshaft MAG end gear is visible.

4. Apply Polaris PS-4 engine oil to both balance shaft journals (Item 2).

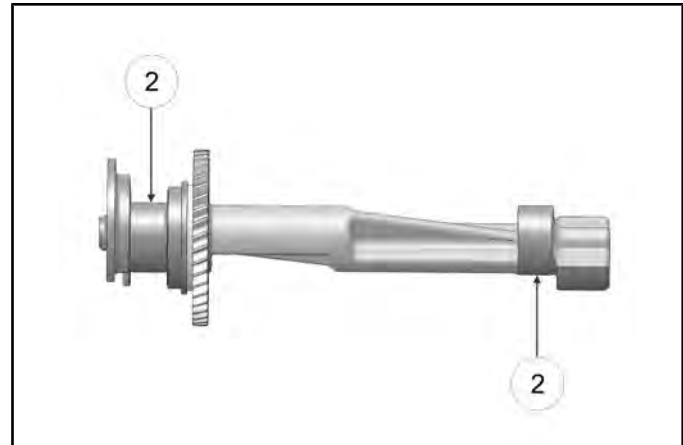

5. Install the balance shaft, placing the tooth with the alignment dot (Item 3) in-line with the dot (Item 4) on the crankshaft gear (see reference images below).

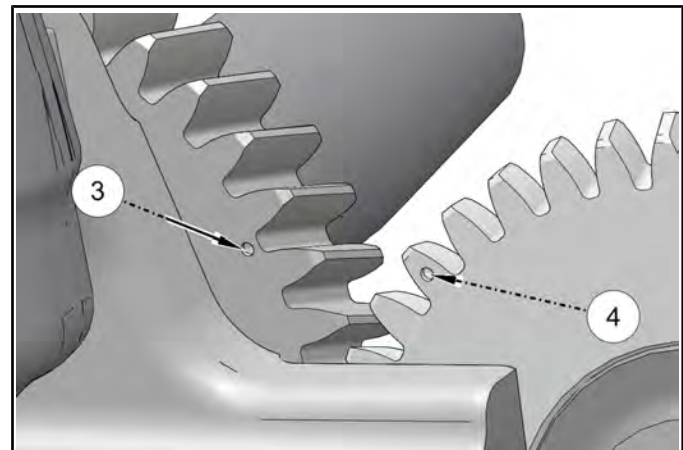

## Lower Crankcase Preparation

**NOTE:** Always replace plain bearings when the crankcase or connecting rods have been disassembled. Refer to bearing selection procedures.

1. Remove all traces of crankcase sealant from the crankcase mating surfaces. Inspect the surfaces closely for nicks, burrs or damage.
2. Clean bolt hole threads to remove any oil or crankcase sealant.
3. Inspect crankcase bearing bores. Replace the crankcase assembly if a bearing bore is galled or if bearing inserts have rotated in the case.
4. Be sure alignment pins are in place where used.



## ENGINE

5. Refer to "Oil Flow Chart" at the beginning of this chapter and trace the oil paths through the crankcase and cylinder.
6. Flush all oil passages with solvent and then warm soapy water. Rinse with clear, warm water and dry with compressed air.
7. Be sure passages are clean and dry before assembling the crankcase.

### Crankcase Assembly

1. Check to be sure the PTO crankshaft seal is resting properly in the upper crankcase.
2. Align tab of new main bearings (Item 1) and new balance shaft bearings (Item 2) with the slot in each bearing bore of the lower crankcase. Press bearing inserts firmly into place.

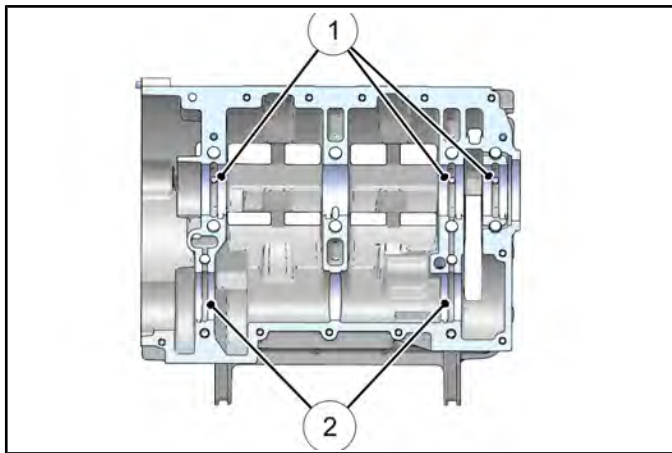

3. Apply Polaris PS-4 engine oil to the new bearings installed in the lower crankcase half.
4. Clean crankcase mating surfaces to remove any oil.

5. Apply a thin, continuous film of Crankcase Sealant (PN 2871557) to upper crankcase mating surface (Item 3) as shown. Do not allow sealant to dry before assembly.

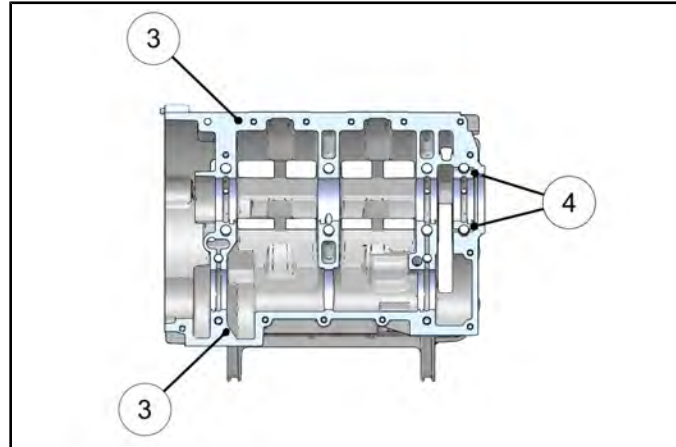

**NOTE: DO NOT block oil passages (Item 4) with crankcase sealant.**

6. Carefully place lower crankcase on upper case, making sure the oil pump drive chain is fed through the lower crankcase.

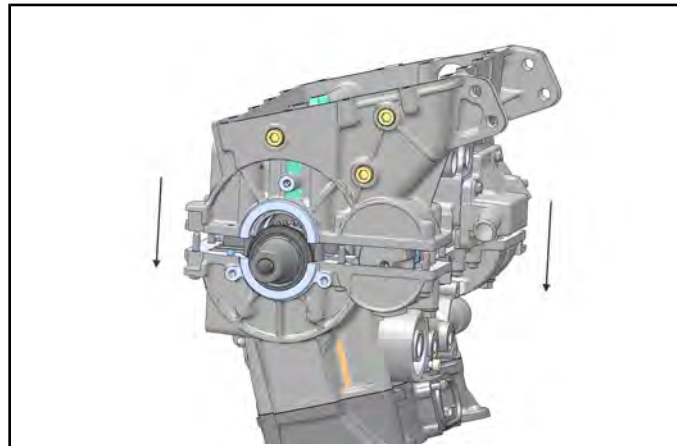

7. Tap lower crankcase with a rubber hammer to seat the case halves together.
8. Inspect crankcase mating surfaces to be sure they are joined properly. Investigate the cause of any gaps.

9. Install the eight M10 (Item 5), two M8 (Item 7) and one M6 (Item 6) lower crankcase bolts. Tighten all bolts lightly by hand.

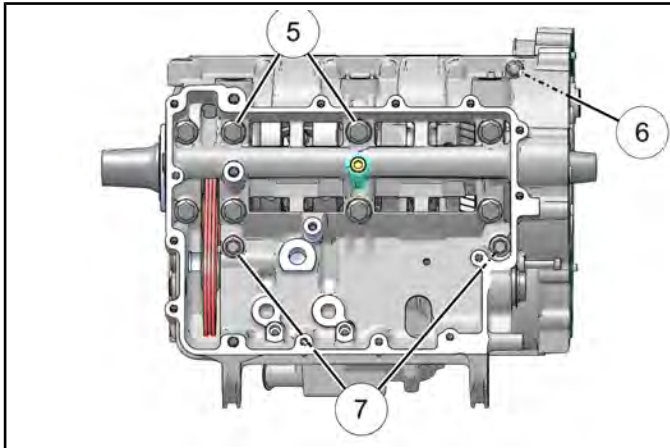

**NOTE: Install new M10 lower crankcase bolts.**

10. Torque lower crankcase bolts in sequence to specification. Repeat sequence to verify final torque.

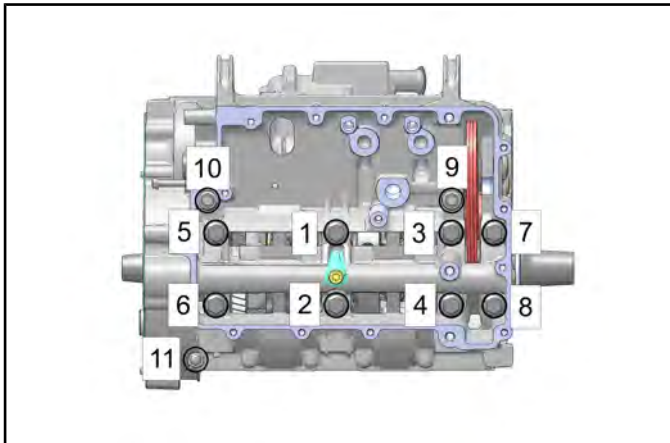

Lower Crankcase Bolts:  
 M10 Bolts:  
**Step 1: 9 ft-lb (12 Nm)**  
**Step 2: 21 ft-lb (28 Nm)**  
**Step 3: Tighten add'n 90°**

M8 Bolts: **26 ft-lb (35 Nm)**  
 M6 Bolts: **9 ft-lb (12 Nm)**

11. Rotate the engine so the cylinder is facing up.

12. Install the eleven M6 (Item 9) and two M8 (Item 8) upper crankcase bolts. Tighten all bolts lightly by hand.

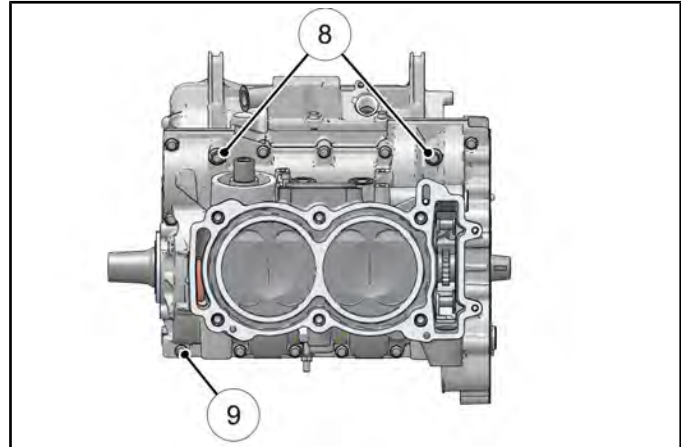

13. Torque the upper crankcase bolts in sequence to specification (start with #12). Repeat the sequence to verify final torque.

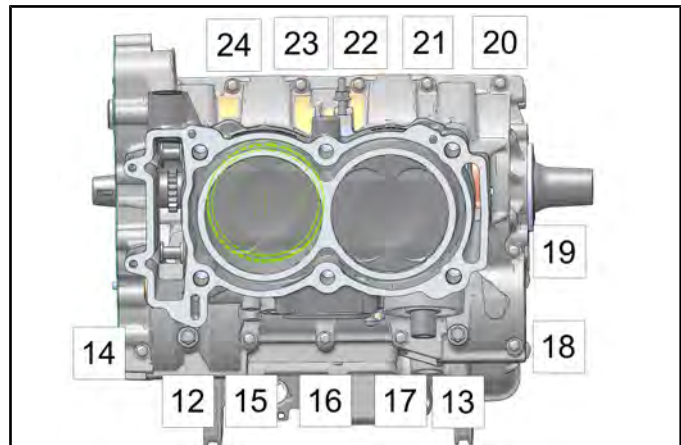

Upper Crankcase Bolts:  
 M8 Bolts: **26 ft-lb (35 Nm)**  
 M6 Bolts: **9 ft-lb (12 Nm)**

14. Rotate the engine so the cylinder is facing down.  
 15. Install a new seal on the oil pump.

# ENGINE

16. Lift the oil pump drive chain and install the oil pump.

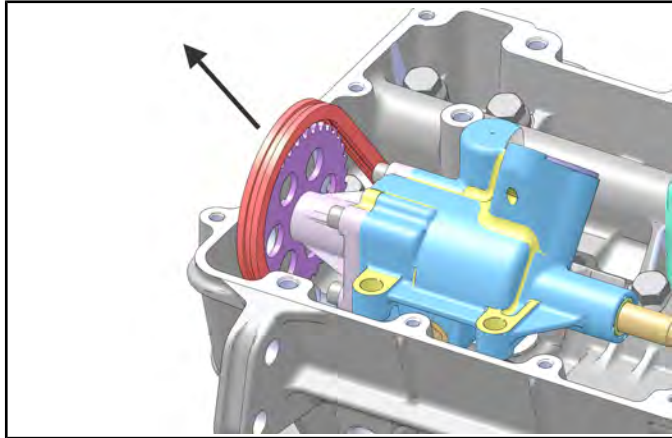

17. Install dowel pins (Item 10) into oil pump mounting holes.

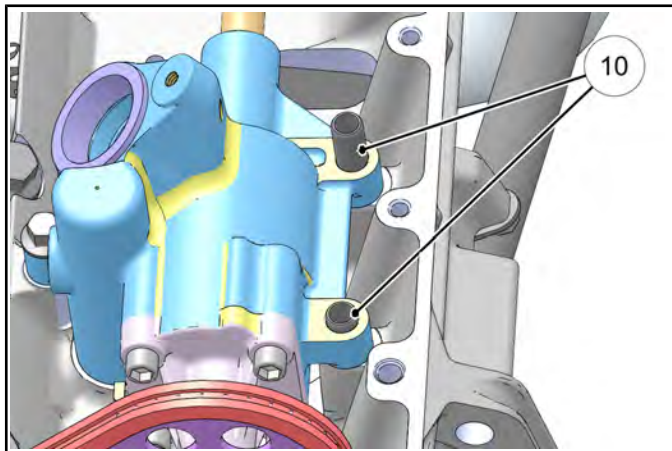

18. Install the three bolts (Item 13) that retain oil pump (Item 12) to the crankcase. Torque mounting bolts to specification.

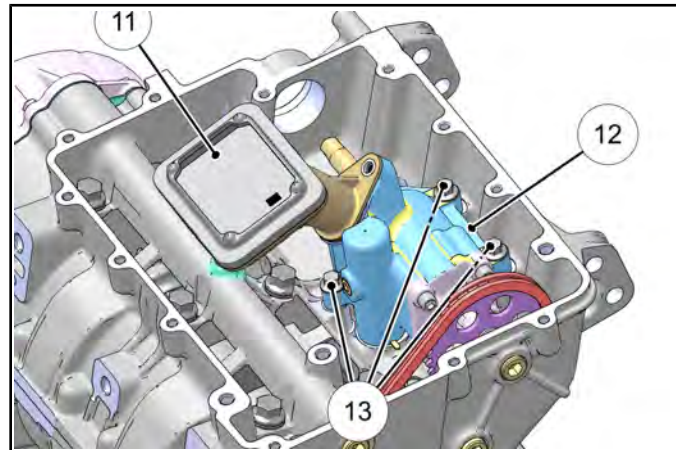

Oil Pump Mounting Bolts:  
**7 ft-lbs (10 Nm)**

19. Reinstall oil pump pick-up (Item 11). Torque mounting screws to specification.



Oil Pump Pick-Up Retaining Screws:  
**7 ft-lb (10 Nm)**

20. Clean the gasket sealing surfaces on oil sump cover and crankcase to remove old gasket material and any oil.

**NOTE: Gasket surfaces must be DRY and oil free. Use care upon assembly to keep oil away.**

21. Apply a thin, continuous film of Crankcase Sealant (PN 2871557) to sump cover mating surface (Item 14) as shown. Do not allow sealant to dry before assembly.

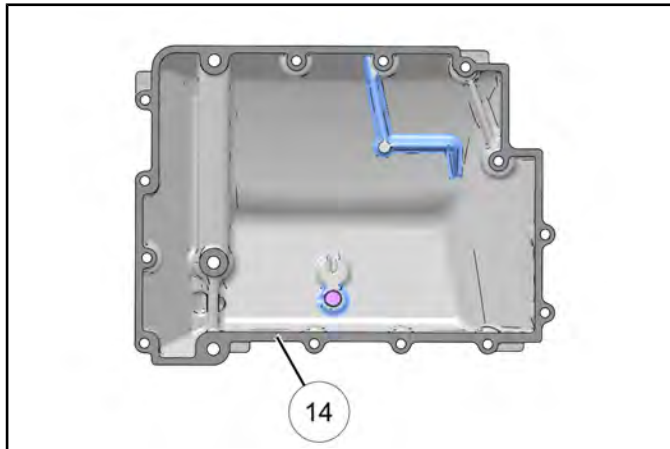

22. Install the oil sump cover (Item 15) onto the crankcase.

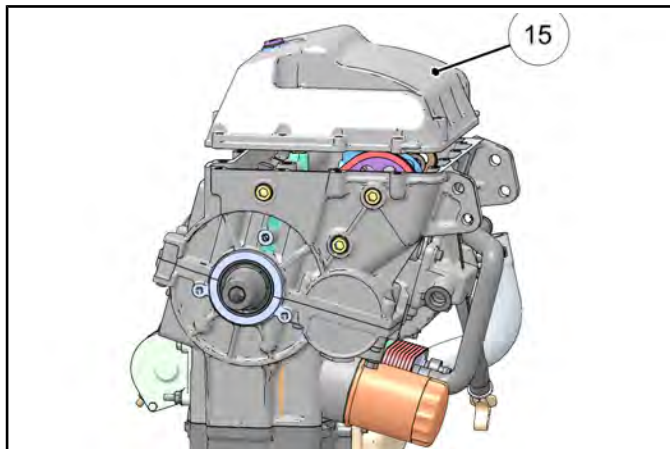

23. Install the thirteen M6 (Item 16) and three M8 bolts that retain the oil sump cover (Item 17) to the crankcase.

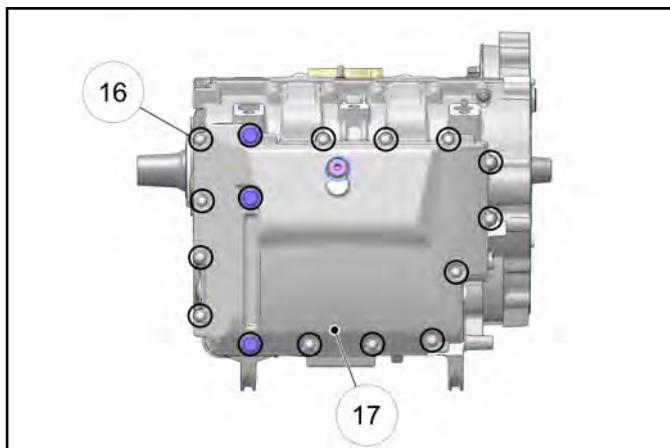

24. Torque the oil sump cover bolts in sequence to specification. Repeat the sequence to verify final torque.

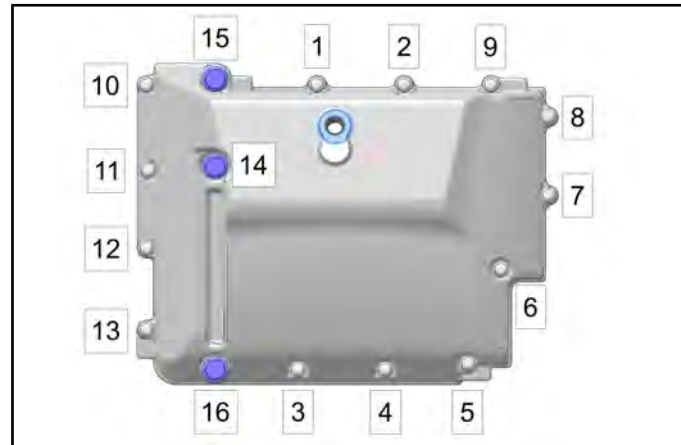

Oil Sump Cover Bolts:

*M8 Bolts:*  
**26 ft-lb (35 Nm)**

*M6 Bolts:*  
**106 in-lb (12 Nm)**

25. Reinstall the crankcase drain plug if previously removed. Torque drain plug to specification.



Crankcase Drain Plug:  
**12 ft-lbs (16 Nm)**

# ENGINE

26. Reinstall the oil cooler (Item 18), if previously removed. Use *new O-rings* (Item 19) upon installation. Torque fasteners to specification

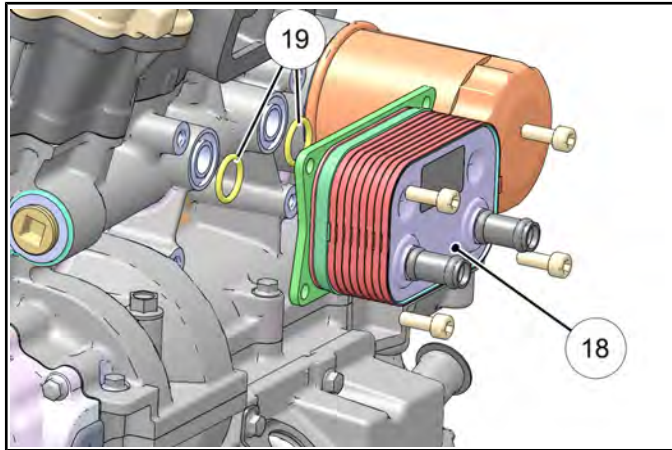

**T** = T  
 Oil Cooler bolts:  
**7 ft-lbs (10 Nm)**

27. Proceed to Flywheel Installation, page 3.73 and then Cylinder Head Installation, page 3.75.

## Starter One-Way Clutch Assembly

1. Install one-way clutch in clutch hub with flange of clutch (Item 1) engaged in recess.

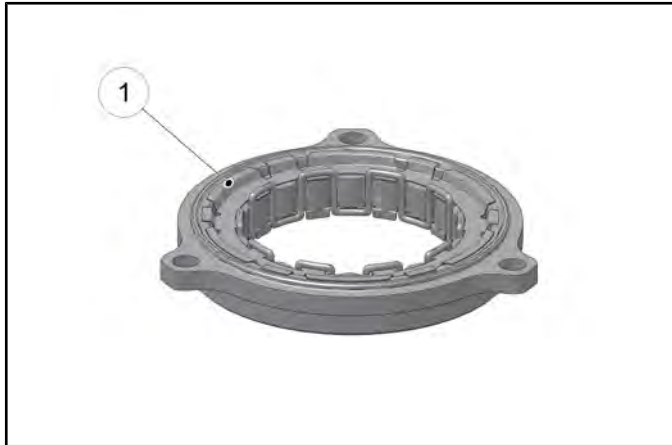

2. Clean screw threads in flywheel to remove all oil or grease.

3. Place one-way clutch on flywheel and install the three screws. Torque screws to specification.

**T** = T  
 One-Way Clutch Retaining Screws:  
**9 ft-lb (12 Nm)**

4. Reassemble starter one-way clutch and gear using the following illustration.

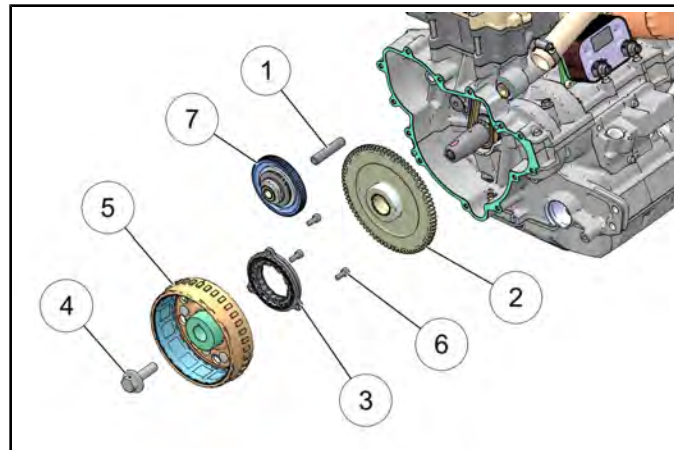

1. Torque Limit Gear Pin	5. Flywheel
2. Starter Gear	6. Screws <b>9 ft-lb (12 Nm)</b>
3. One Way Clutch Asm.	7. Torque Limit Gear Asm.
4. Bolt <b>133 ft-lbs (180 Nm)</b>	

5. If starter gear was replaced, inspect the torque limit gear.

6. After assembly, be sure the starter gear rotates in the clockwise direction only.

## Flywheel Installation

1. If previously removed, reinstall the flywheel key.
2. Clean taper of crankshaft to remove all oil or grease.
3. Clean flywheel taper to remove all oil or grease.
4. Align flywheel key-way with key and install the flywheel, seating it fully on taper.
5. Install flywheel retaining bolt. Using a commercially available strap wrench (Item 2), hold flywheel and torque the retaining bolt (Item 1) to specification.

**NOTE:** If the **Cylinder Holding & Camshaft Timing Plate (PU-50563)** is installed, remove it before tightening the flywheel.

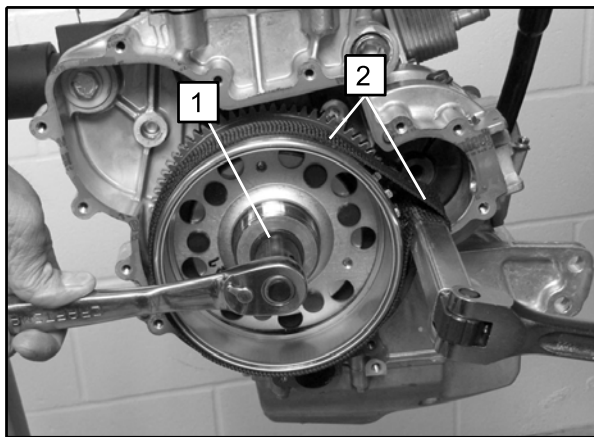

Flywheel Retaining Bolt:  
133 ft-lbs (180 Nm)

## Stator Cover Installation

1. Apply gasket tack adhesive to help hold gasket in place during assembly.
2. Install a new stator cover gasket over alignment pins.

### CAUTION

The flywheel contains powerful magnets. Use caution when removing and installing the stator cover. **DO NOT** place fingers between cover and crankcase at any time during the removal / installation process or injury could result.

3. Install stator cover and thirteenscrews. Torque screws in sequence to specification.

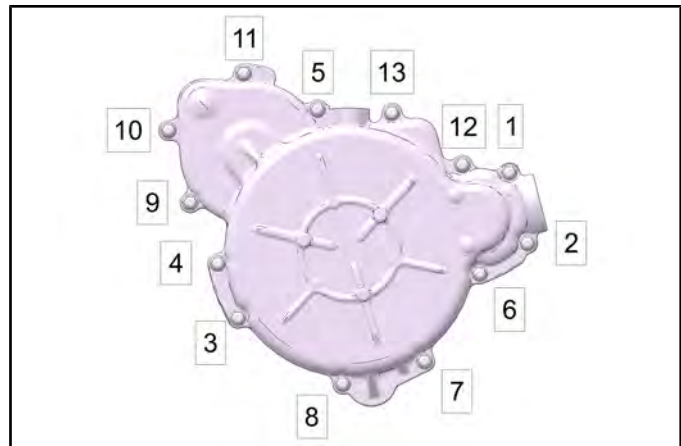

Stator Cover Screws:  
9 ft-lb (12 Nm)

6. Install the starter torque limit gear as an assembly.

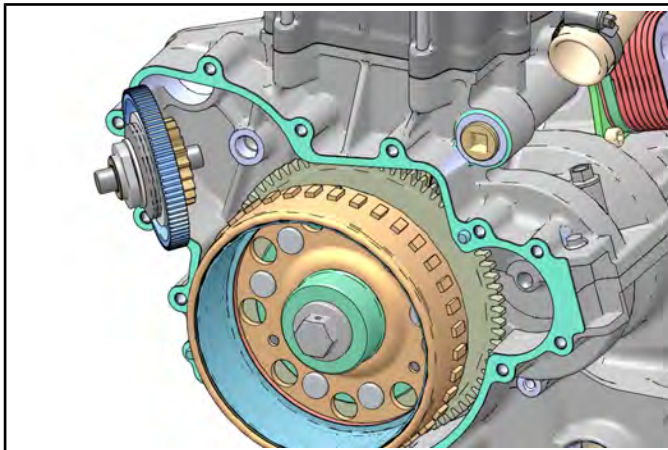

# ENGINE

## ENGINE ASSEMBLY - TOP END

### Cylinder Head Assembly

**NOTE:** Assemble the valves one at a time to maintain proper order.

 **WARNING**

Wear eye protection during cylinder head disassembly and reassembly or when working with the valve springs.

1. Apply engine oil to valve guides and seats.
2. Coat valve stem with Premium Starter Grease (2871460).
3. Install the valve (Item 1) in the cylinder head, through the guide.

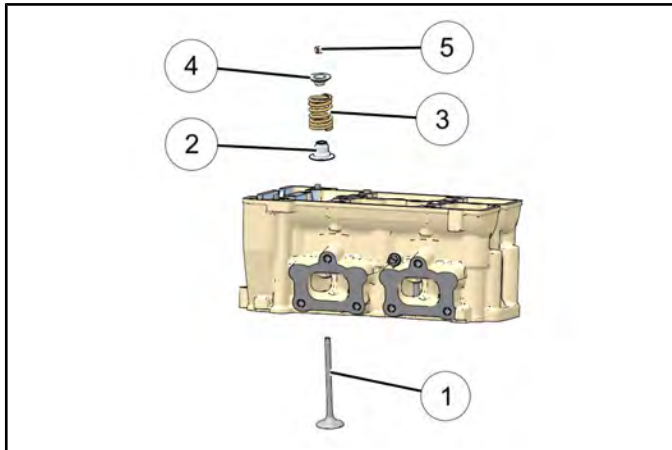

4. Dip the new valve seat/seal (Item 2) in clean engine oil and carefully install the valve seat/seal on the valve guide with a rotating motion. Push firmly until seated in retaining groove and square with the guide

**NOTE:** Valve seals should be installed **AFTER** the valves are in the head to avoid valve seal damage.

5. Dip the valve spring (Item 3) and retainer (Item 4) in clean engine oil.

6. Install the valve spring with widely spaced coils (Item 6) on the top and tightly spaced coils (Item 7) facing down toward the cylinder head.

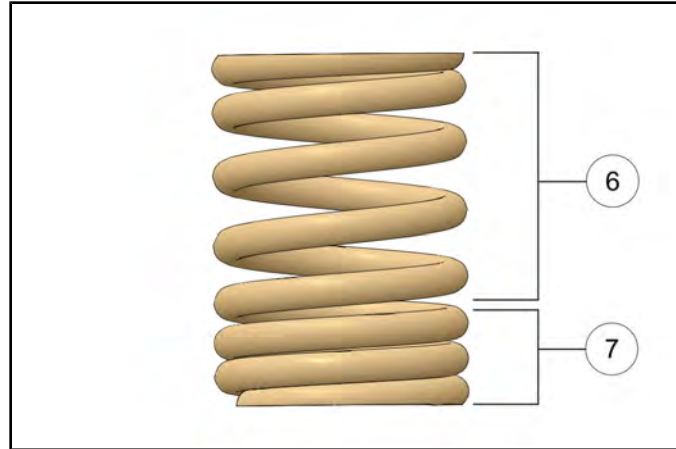

**NOTE:** Valve springs to be installed with paint mark facing up (Item 8).

7. Place the valve retainer on the spring.
8. Compress the valve spring by hand using valve spring compressor adapter (PV-43513-A). Compress spring only enough to allow split keeper installation.

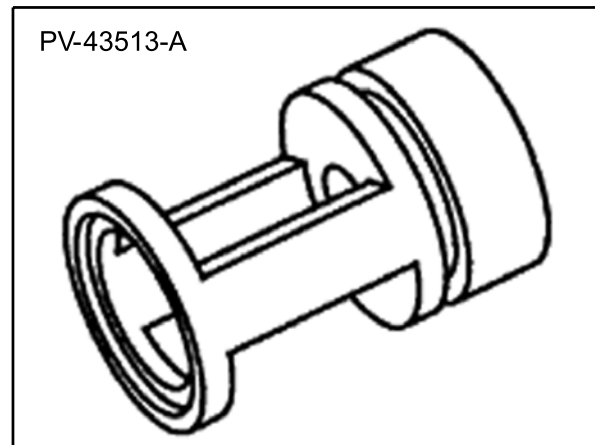

**NOTE:** To prevent damage to the valve seals, do not compress the valve spring more than necessary to install the keepers.

9. Install split keepers (Item 5) with gap even on both sides.
10. Repeat this procedure for remaining valves.

11. Install the valve adjustment tappet (Item 8) for each valve in the order they were removed.

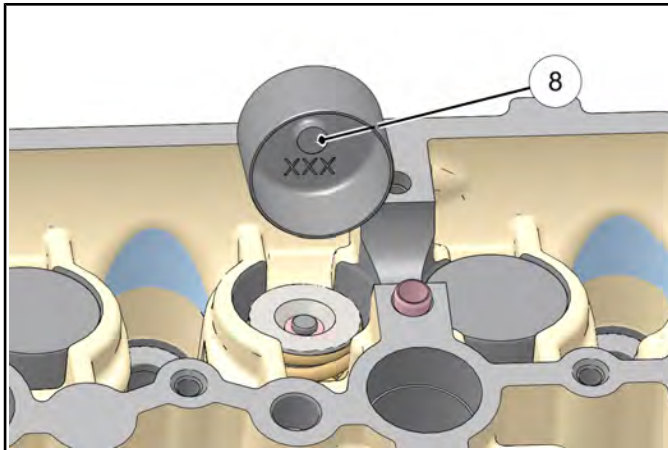

**NOTE:** Refer to **Valve Clearance Adjustment**, page 3.81 procedure for proper tappet selection.

**NOTE:** If any valve train components were replaced, refer to “Valve Clearance Adjustment”, page 3.81 procedure prior to **Camshaft Installation / Timing**, page 3.76 procedure.

## Cylinder Head Installation

1. Rotate the engine so the cylinder is facing up.
2. Remove the Cylinder Holding & Camshaft Timing Plate (PU-50563) (Item 1) from the cylinder.

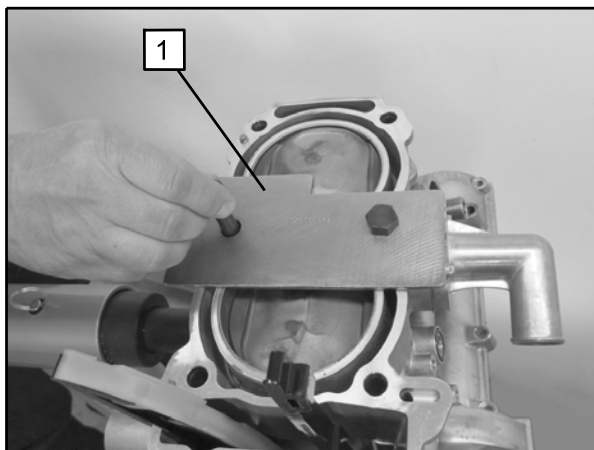

**NOTE:** Once the cylinder head is removed, nothing retains the cylinder to the engine. **DO NOT** rotate the engine without using the **Cylinder Holding & Camshaft Timing Plate (PU-50563)**.

3. Prepare cylinder head gasket sealing surfaces by cleaning thoroughly to remove all residue. The head gasket must be installed clean and dry, free from oil or grease.

**NOTE:** Do not touch sealing surfaces of gasket.

4. Guide cam chain (Item 2) through a new head gasket (Item 3) and install the gasket on the cylinder, locating it on the alignment pins.

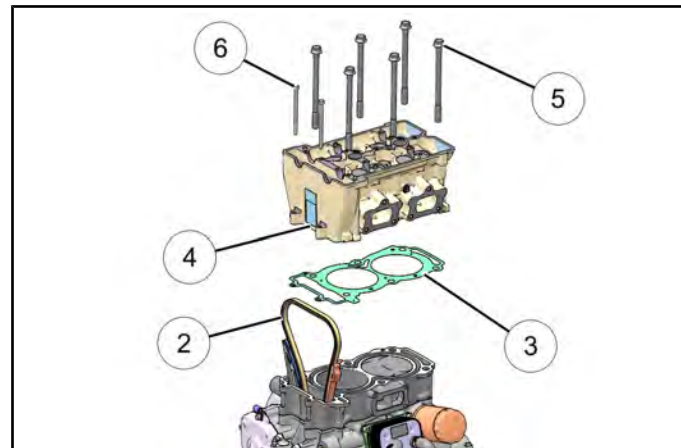

5. Carefully set the cylinder head (Item 4) in place on alignment pins.
6. Install *new bolts* and finger tighten the six cylinder head bolts (Item 5) evenly.
7. Install and finger tighten the two outer M6 bolts (Item 6) evenly.

**NOTE:** Install new cylinder head bolts.



# ENGINE

8. Torque cylinder head bolts in sequence to specification.

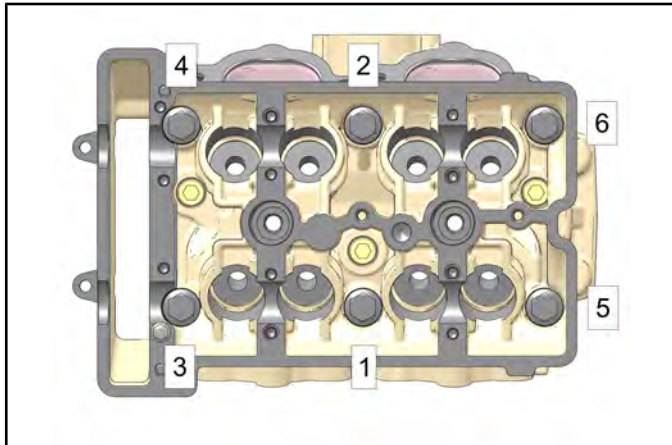

Cylinder Head Torque Procedure:  
**Torque in sequence**  
**Step 1: 9 ft-lbs (12 Nm)**  
**Step 2: 26 ft-lb (35 Nm)**  
**Step 3: Additional 180°**  
**Step 4: M6 bolts: 7 ft-lb (10 Nm)**

## Camshaft Installation / Timing

**NOTE:** If any valve train components were replaced, refer to **Valve Clearance Adjustment**, page 3.81 procedure prior to **Camshaft Installation / Timing**, page 3.76.

1. Rotate the engine until the flywheel Top Dead Center (TDC) mark (Item 1) is aligned or centered in the Crankshaft Position Sensor (CPS) mounting hole (Item 2). This places the PTO cylinder at TDC for camshaft installation.

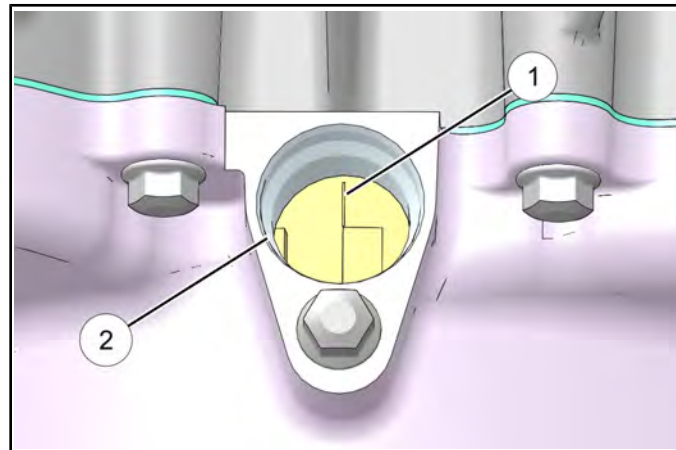

**NOTE:** DO NOT use the “V” mark located on the flywheel opposite of the “I” mark. Only the “I” mark should be used as a TDC reference.

2. Reference the intake and exhaust markings made during disassembly. If installing new camshafts or if camshafts were not marked, you can reference the part number stamped on the end of the shafts.

**Intake Camshaft - PN 1204784**  
**Exhaust Camshaft - PN 1204786**

3. Lubricate all camshaft lobes and bearing journal surfaces with Polaris PS-4 engine oil prior to installation.

- Carefully install the camshafts into the cylinder head. The PTO camshaft lobes (Item 5) should face out as shown.

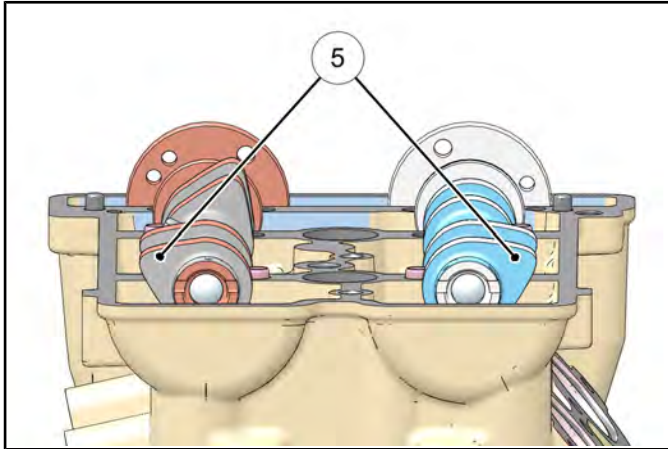

- Carefully install the rear camshaft carriers onto the camshafts. Carrier openings should face each other when installed properly.
- Install the four bolts that retain each rear camshaft carrier (Item 6) and tighten the bolts evenly until snug.

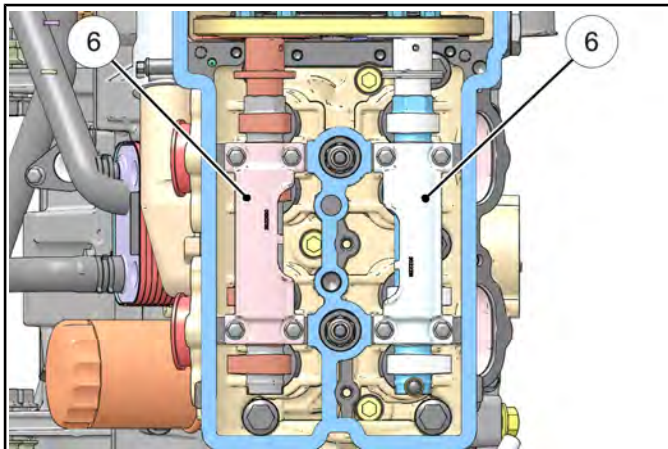

- Install the Cylinder Holding & Camshaft Timing Plate (PU-50563) into the end of camshafts as shown. Use a 13/16" open-end wrench to rotate camshafts slightly if needed.

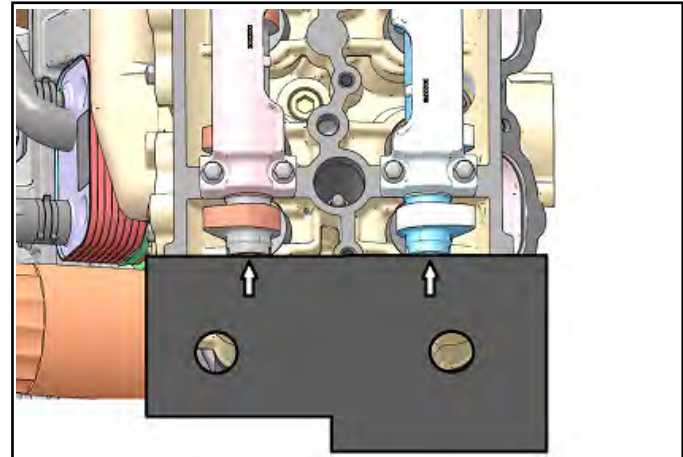

- Verify the TDC mark on the flywheel is still properly aligned (see Step 1).
- Pull cam chain upward, making sure it is engaged with the drive sprocket on the crankshaft.
- While lifting the cam chain up, engage the cam sprockets into the chain with the "I" and "E" marks facing out.
- Install the sprockets onto the camshafts and align the sprocket marks with the valve cover gasket surface (see Camshaft Timing - Quick Reference, page 3.80).

**NOTE:** Intake cam sprocket should have "I" marks aligned with gasket surface and the exhaust cam sprocket should have "E" marks aligned with gasket surface. Install the exhaust cam sprocket first (opposite the cam chain tensioner) to ensure proper cam timing.

## ENGINE

12. Use *new* camshaft sprocket retaining bolts upon assembly. Install the top bolt (Item 8) in each camshaft sprocket (Item 7). Do not torque the bolts at this time.

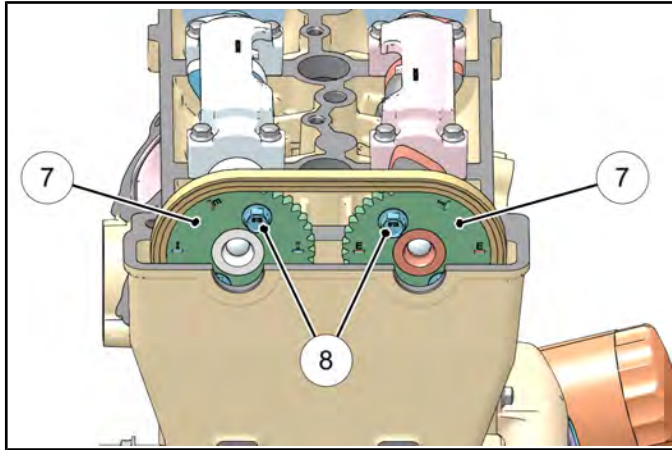

**NOTE:** Use new sprocket retaining bolts upon assembly.

13. Verify cam timing is correct. Flywheel TDC mark should still be aligned (see Step 1) and cam sprocket markings should line up as shown.

### TIMING VIEW FOR SPROCKETS

FOR CORRECT SPROCKET ORIENTATION, INSURE THE "I" FOR INTAKE ON CAM 1204052 AND THE "E" FOR EXHAUST ON CAM 1204053 ARE POSITIONED AS SHOWN. VIEWED FROM MAG SIDE.

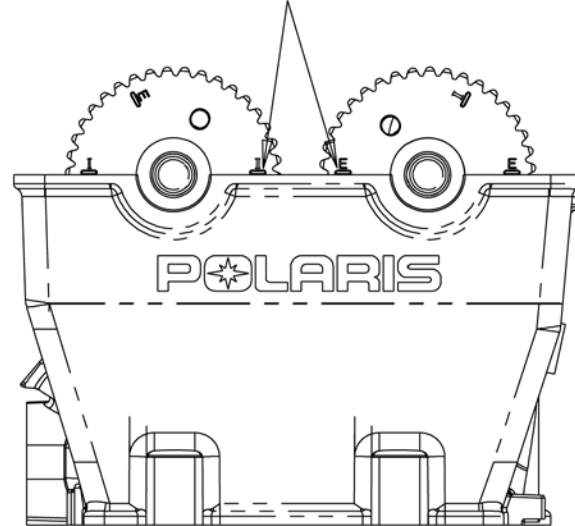

### TIMING VIEW FOR CAMSHAFTS

1. ALIGN SLOT OF BOTH CAMS WITH THE TOP DECK OF THE HEAD.
2. POSITION 4MM THICK FLAT BAR THROUGH SLOTS TO LOCK CAMS IN CORRECT POSITION.

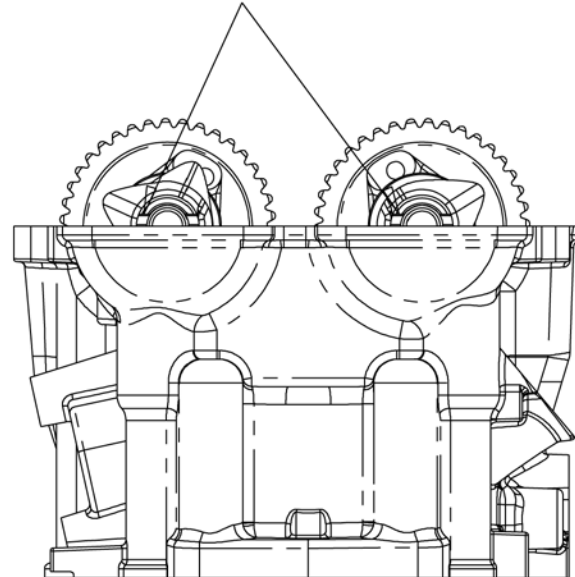

14. If timing marks are not aligned, remove sprockets and correct alignment.
15. Remove the Cylinder Holding & Camshaft Timing Plate (PU-50563) from the end of the camshafts.
16. Rotate the engine using the flywheel and install the remaining bolt in each camshaft sprocket. Torque the sprocket bolts to specification.

 = T

---

**Camshaft Sprocket Bolts:  
14 ft-lb (19 Nm)**

17. Rotate the engine using the flywheel and torque the remaining sprocket bolts to specification.
18. Install the front camshaft carrier (Item 9) and two outer retaining bolts.

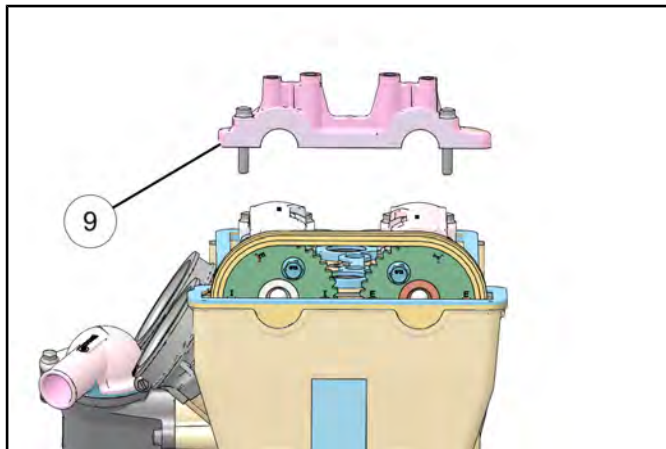

19. Install the fixed cam chain guide (Item 10) and two retaining bolts.

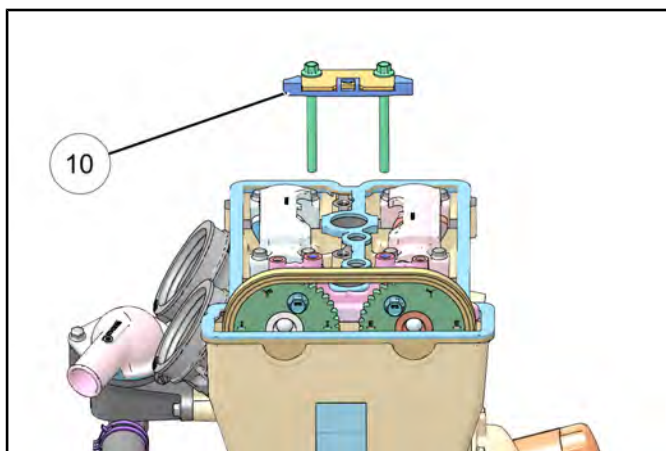

20. Torque the camshaft carriers bolts in sequence to specification.

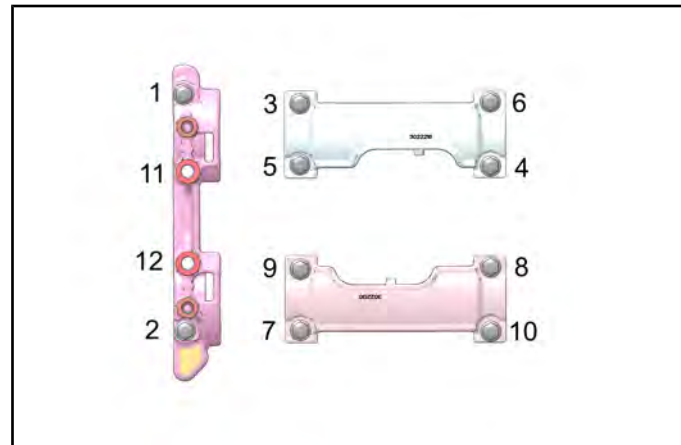



 = T

---

**Camshaft Carrier Bolts:  
7 ft-lb (10 Nm)**

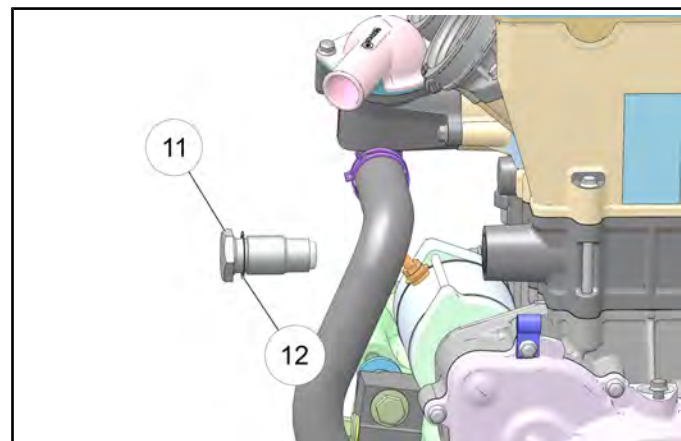
21. Apply Polaris PS-4 engine oil to the cam chain tensioner bore prior to assembly. Use a *new* tensioner sealing washer (Item 12).
22. Install the hydraulic cam chain tensioner (Item 11) into the cylinder and torque to specification.



 = T

---

**Cam Chain Tensioner:  
29 ft-lb (40 Nm)**

23. Rotate crankshaft through two revolutions and verify camshaft timing is correct.

# ENGINE

## Camshaft Timing - Quick Reference

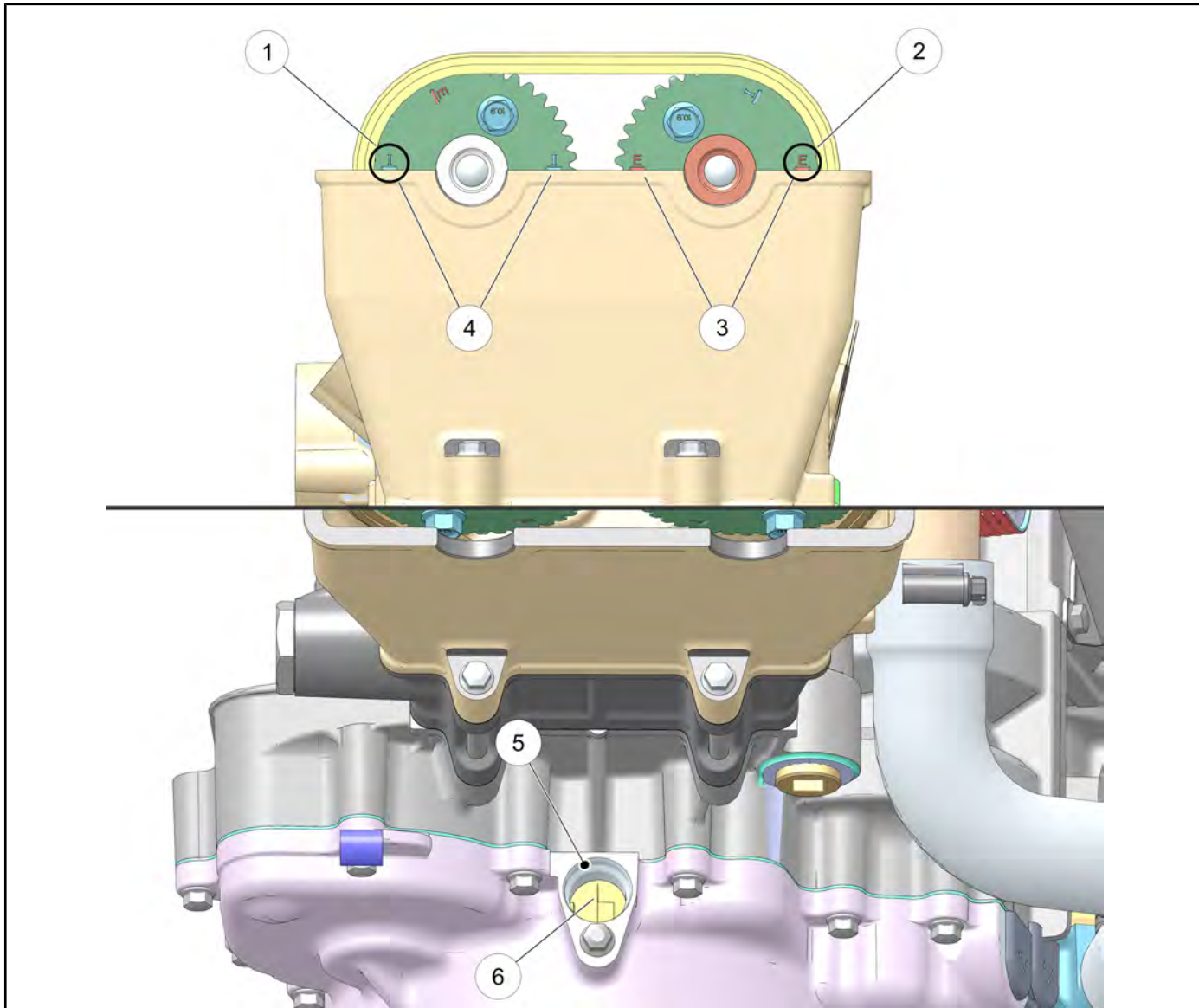

1. Intake Cam	4. Align marks with surface
2. Exhaust Cam	5. CPS Mounting Hole
3. Align marks with surface	6. Align Flywheel Mark in Mounting Hole

**Important**  
DO NOT use the “V” mark located on the flywheel opposite of the “I” mark. Only the “I” mark should be used as a TDC reference

## Valve Clearance Adjustment

**NOTE: Always inspect valve clearance prior to camshaft installation or final engine assembly.**

1. Reference the camshaft intake and exhaust markings made during disassembly. If installing new camshafts or if camshafts were not marked, you can reference the part number stamped on the end of the shafts.

**Intake Camshaft - PN 1204784  
Exhaust Camshaft - PN 1204786**

2. Lubricate the camshaft bearing journal surfaces with Polaris PS-4 engine oil prior to installation.
3. Carefully install the camshafts into the cylinder head. The PTO camshaft lobes (Item 3) should face out as shown.

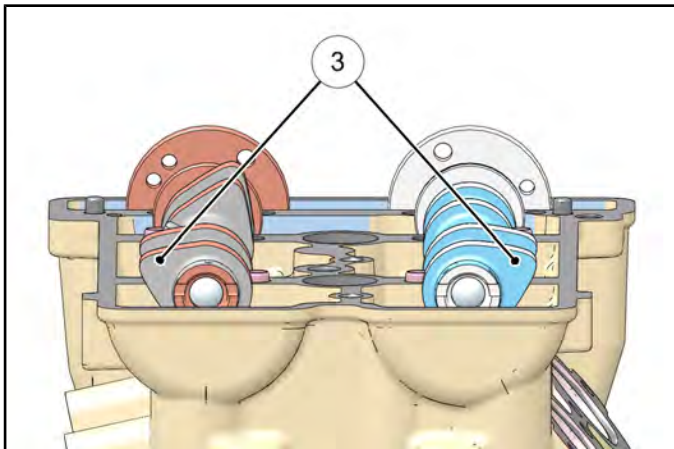

4. Carefully install the rear camshaft carriers onto the camshafts. Carrier openings should face each other when installed properly.

5. Install the four bolts that retain each rear camshaft carrier (Item 4 & 5) and tighten the bolts evenly to specification.

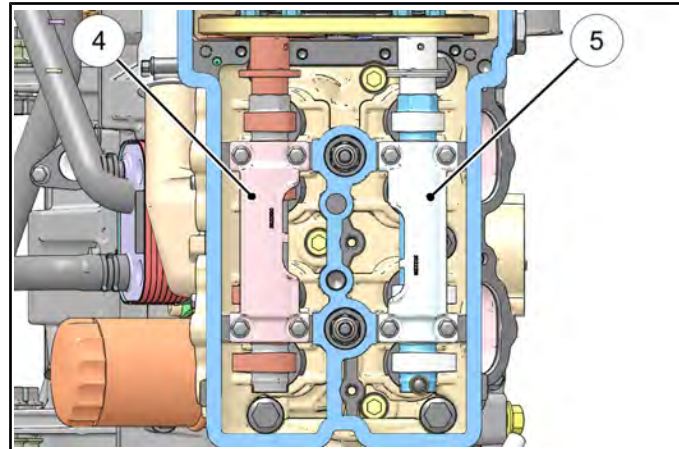

**Camshaft Carrier Bolts:  
7 ft-lb (10 Nm)**

6. Rotate the camshaft until the cam lobes above the valves you are inspecting are facing up (Item 6).

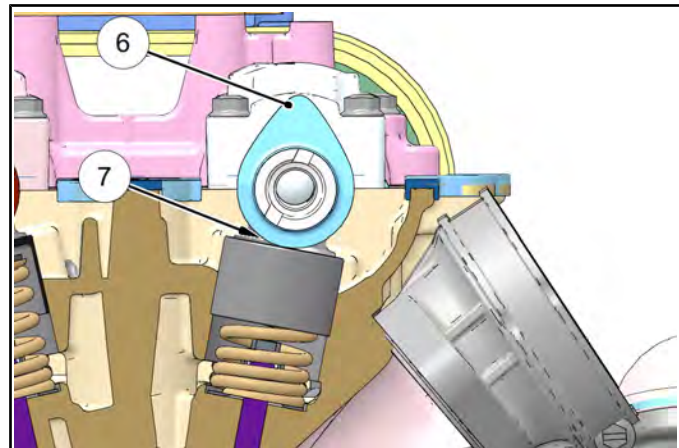

7. Measure the valve clearance (Item 7) using a thickness (feeler) gauge. Record the measurement if clearance is out of specification.

**3**

# ENGINE

8. Repeat steps 6 and 7 until all eight valves have been inspected.

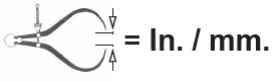

Intake Valve Clearance (cold):  
**0.006 ± 0.002" (0.15 ± 0.5 mm)**

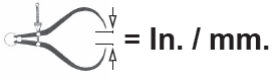

Exhaust Valve Clearance (cold):  
**0.008 ± 0.002" (0.20 ± 0.5 mm)**

9. If any of the valve clearance measurements are out of specification, remove the camshaft carriers and camshafts and proceed with this procedure.

**NOTE: If all valve clearance measurements are within specification, remove the camshaft carriers and proceed to Camshaft Installation / Timing, page 3.76.**

10. Remove the valve tappet from a valve that was out of specification.

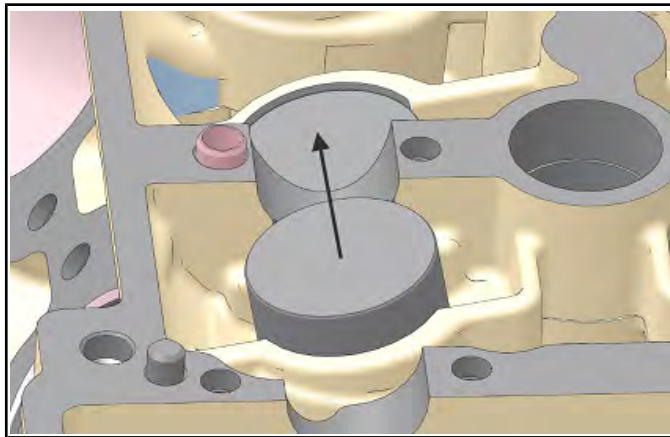

**NOTE: Keep mated parts together and in order with respect to their location in the cylinder head for assembly purposes. Mark each component or place them in an organized rack as you remove them.**

11. Record the 3 digit number on the bottom of the tappet. (Item 8).

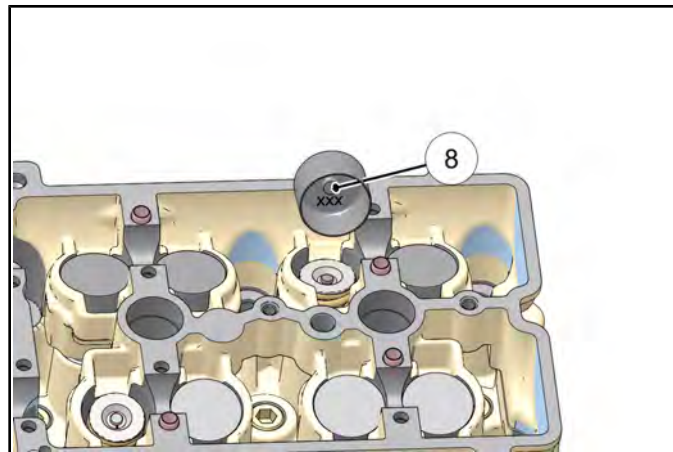

12. Reference the valve clearance measurement recorded for that valve, along with the 3-digit tappet number.

13. Refer to the appropriate tappet selection matrix (Intake or Exhaust) on the following pages and select the proper tappet.

14. Install the proper tappet.

**NOTE: Lubricate the outer portion of the valve tappet upon installation.**

15. Repeat steps 10-14 until all necessary valves have been adjusted.

16. Reinstall the camshafts and camshaft carriers and tighten the bolts evenly to specification.



Camshaft Carrier Bolts:  
**7 ft-lb (10 Nm)**

17. Measure and confirm that valve clearance is now within specification for each valve.

18. If valve clearance is not within specification, repeat this procedure.

19. If all valve clearance measurements are now within specification, remove the camshaft carriers and proceed to Camshaft Installation / Timing, page 3.76.

**Intake Valve Lash - Tappet Selection Matrix**

Tappet Thickness: Example 440 equals thickness of 4.40 mm. Part Number: 5138477-XXX (X's represent 3 digits on tappet)



= In. / mm.

---

Intake Valve Clearance:  
**0.006 ± 0.002" (0.15 ± 0.5 mm)**

		Existing Valve Lash Tappet Marking (3 digits on tappet)																																			
		440	442	445	448	450	452	455	458	460	462	465	468	470	472	475	478	480	482	485	488	490	492	495	498	500	502	505	508	510	512	515	518	520	522	525	
		Correct Valve Lash Tappet Marking (3 digits on tappet)																																			
<b>Intake Valve Clearance Before Adjusting (mm)</b>	0.000-0.024	428	430	432	435	438	440	442	445	448	450	452	455	458	460	462	465	468	470	472	475	478	480	482	485	488	490	492	495	498	500	502	505	508	510	512	
	0.025-0.049	430	432	435	438	440	442	445	448	450	452	455	458	460	462	465	468	470	472	475	478	480	482	485	488	490	492	495	498	500	502	505	508	510	512	515	
	0.050-0.074	432	435	438	440	442	445	448	450	452	455	458	460	462	465	468	470	472	475	478	480	482	485	488	490	492	495	498	500	502	505	508	510	512	515	518	
	0.075-0.099	435	438	440	442	445	448	450	452	455	458	460	462	465	468	470	472	475	478	480	482	485	488	490	492	495	498	500	502	505	508	510	512	515	518	520	
	0.100-0.200 (Standard)																																				
	0.201-0.225	448	450	452	455	458	460	462	465	468	470	472	475	478	480	482	485	488	490	492	495	498	500	502	505	508	510	512	515	518	520	522	525	528	530	532	
	0.226-0.250	450	452	455	458	460	462	465	468	470	472	475	478	480	482	485	488	490	492	495	498	500	502	505	508	510	512	515	518	520	522	525	528	530	532	535	
	0.251-0.275	452	455	458	460	462	465	468	470	472	475	478	480	482	485	488	490	492	495	498	500	502	505	508	510	512	515	518	520	522	525	528	530	532	535	538	
	0.276-0.300	455	458	460	462	465	468	470	472	475	478	480	482	485	488	490	492	495	498	500	502	505	508	510	512	515	518	520	522	525	528	530	532	535	538	540	542
	0.301-0.325	458	460	462	465	468	470	472	475	478	480	482	485	488	490	492	495	498	500	502	505	508	510	512	515	518	520	522	525	528	530	532	535	538	540	542	545
	0.326-0.350	460	462	465	468	470	472	475	478	480	482	485	488	490	492	495	498	500	502	505	508	510	512	515	518	520	522	525	528	530	532	535	538	540	542	545	
	0.351-0.375	462	465	468	470	472	475	478	480	482	485	488	490	492	495	498	500	502	505	508	510	512	515	518	520	522	525	528	530	532	535	538	540	542	545		
	0.376-0.400	465	468	470	472	475	478	480	482	485	488	490	492	495	498	500	502	505	508	510	512	515	518	520	522	525	528	530	532	535	538	540	542	545			
	0.401-0.425	468	470	472	475	478	480	482	485	488	490	492	495	498	500	502	505	508	510	512	515	518	520	522	525	528	530	532	535	538	540	542	545				
	0.426-0.450	470	472	475	478	480	482	485	488	490	492	495	498	500	502	505	508	510	512	515	518	520	522	525	528	530	532	535	538	540	542	545					
	0.451-0.475	472	475	478	480	482	485	488	490	492	495	498	500	502	505	508	510	512	515	518	520	522	525	528	530	532	535	538	540	542	545						
	0.476-0.500	475	478	480	482	485	488	490	492	495	498	500	502	505	508	510	512	515	518	520	522	525	528	530	532	535	538	540	542	545							
	0.501-0.525	478	480	482	485	488	490	492	495	498	500	502	505	508	510	512	515	518	520	522	525	528	530	532	535	538	540	542	545								
	0.526-0.550	480	482	485	488	490	492	495	498	500	502	505	508	510	512	515	518	520	522	525	528	530	532	535	538	540	542	545									
	0.551-0.575	482	485	488	490	492	495	498	500	502	505	508	510	512	515	518	520	522	525	528	530	532	535	538	540	542	545										
	0.576-0.600	485	488	490	492	495	498	500	502	505	508	510	512	515	518	520	522	525	528	530	532	535	538	540	542	545											
	0.601-0.625	488	490	492	495	498	500	502	505	508	510	512	515	518	520	522	525	528	530	532	535	538	540	542	545												
	0.626-0.650	490	492	495	498	500	502	505	508	510	512	515	518	520	522	525	528	530	532	535	538	540	542	545													
	0.651-0.675	492	495	498	500	502	505	508	510	512	515	518	520	522	525	528	530	532	535	538	540	542	545														
	0.676-0.700	495	498	500	502	505	508	510	512	515	518	520	522	525	528	530	532	535	538	540	542	545															
	0.701-0.725	498	500	502	505	508	510	512	515	518	520	522	525	528	530	532	535	538	540	542	545																
	0.726-0.750	500	502	505	508	510	512	515	518	520	522	525	528	530	532	535	538	540	542	545																	
	0.751-0.775	502	505	508	510	512	515	518	520	522	525	528	530	532	535	538	540	542	545																		
0.776-0.800	505	508	510	512	515	518	520	522	525	528	530	532	535	538	540	542	545																				
0.801-0.825	508	510	512	515	518	520	522	525	528	530	532	535	538	540	542	545																					
0.826-0.850	510	512	515	518	520	522	525	528	530	532	535	538	540	542	545																						
0.851-0.875	512	515	518	520	522	525	528	530	532	535	538	540	542	545																							
0.876-0.900	515	518	520	522	525	528	530	532	535	538	540	542	545																								
0.901-0.925	518	520	522	525	528	530	532	535	538	540	542	545																									
0.926-0.950	520	522	525	528	530	532	535	538	540	542	545																										
0.951-0.975	522	525	528	530	532	535	538	540	542	545																											
0.976-1.000	525	528	530	532	535	538	540	542	545																												





## Valve Cover Installation

1. Apply anti-seize compound to spark plug threads.
2. Install spark plugs (Item 1) and torque to specification.
3. Prepare valve cover sealing surfaces by cleaning thoroughly to remove all residue.
4. Install valve cover seal (Item 2).
5. Install the four valve cover shoulder bolts (Item 3) and new isolators (Item 4) using a T40 driver.

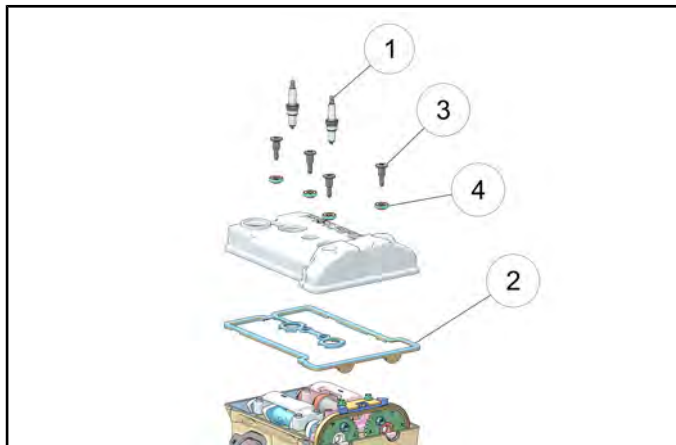

6. Torque valve cover bolts to specification.



Spark Plugs:  
**7 ft-lbs (10 Nm)**

Valve Cover Bolts:  
**7 ft-lbs (10 Nm)**

# ENGINE

---

## TROUBLESHOOTING

### Engine

#### Spark Plug Fouling

- Spark plug cap loose or faulty
- Incorrect spark plug heat range or gap
- PVT system calibrated incorrectly/ components worn or mis-adjusted
- Fuel quality poor (old) or octane too high
- Low compression
- Restricted exhaust
- Weak ignition (loose coil ground, faulty coil, or stator)
- Restricted air filter (main or pre-cleaner) or breather system
- Improperly assembled air intake system
- Restricted engine breather system
- Oil contaminated with fuel

#### Engine Turns Over But Fails To Start

- No fuel
- Dirt in fuel line or filter
- Fuel will not pass through fuel valve
- Fuel pump inoperative/restricted
- Tank vent plugged or pinched
- Engine flooded
- Low compression (high cylinder leakage)
- No spark (Spark plug fouled) ignition component failure

#### Engine Does Not Turn Over

- Dead battery
- Starter motor does not turn
- Engine seized, rusted, or mechanical failure

#### Engine Runs But Will Not Idle

- Restricted fuel supply
- Low compression
- Crankcase breather restricted

#### Engine Idles But Will Not Accelerate

- Spark plug fouled/weak spark
- Broken throttle cable

- Obstruction in air intake
- Air box removed (reinstall all intake components)
- Incorrect ignition timing
- Restricted exhaust system
- Cam worn excessively

#### Engine Has Low Power

- Spark plug fouled
- Cylinder, piston, ring, or valve wear or damage (check compression)
- PVT not operating properly
- Restricted exhaust muffler
- Cam worn excessively

#### Piston Failure - Scoring

- Lack of lubrication
- Dirt entering engine through cracks in air filter or ducts
- Engine oil dirty or contaminated

#### Excessive Smoke and Carbon Buildup

- Excessive piston-to-cylinder clearance
- Wet sumping
- Worn rings, piston, or cylinder
- Worn valve guides or seals
- Restricted breather
- Air filter dirty or contaminated

#### Piston Failure - Scoring

- Lack of lubrication
- Dirt entering engine through cracks in air filter or ducts
- Engine oil dirty or contaminated

#### Excessive Smoke and Carbon Buildup

- Excessive piston-to-cylinder clearance
- Wet sumping due to over-full crankcase
- Worn rings, piston, or cylinder
- Worn valve guides or seals
- Restricted breather
- Air filter dirty or contaminated

#### Low Compression

- Cylinder head gasket leak
- No valve clearance (cam wear)
- Cylinder or piston worn
- Piston rings worn, leaking, broken, or sticking
- Bent valve or stuck valve
- Valve spring broken or weak
- Valve not seating properly (bent or carbon accumulated on sealing surface)
- Rocker arm sticking

## Backfiring

- Fouled spark plug or incorrect plug or plug gap
- Intake system air leaks
- Exhaust system air leaks
- Valve sticking
- Ignition system faulty:
- Spark plug cap cracked / broken
- Ignition coil faulty
- Ignition or kill switch circuit faulty
- Poor connections in ignition system
- Ignition timing incorrect
- Sheared flywheel key

## Cooling System

### Overheating

- Low coolant level
- Air in cooling system
- Wrong type/mix of coolant
- Faulty pressure cap or system leaks
- Restricted system (mud or debris in radiator fins causing restriction to air flow, passages blocked in radiator, lines, pump, or water jacket, accident damage)
- Lean mixture (vents, fuel pump or fuel valve)
- Fuel pump output weak
- Electrical malfunction
- Water pump failure/ Loose impeller
- Thermistor failure
- Cooling fan inoperative or turning too slowly (perform current draw test)
- Low oil level

- Spark plug incorrect heat range
- Faulty hot light circuit
- Thermostat stuck closed or not opening completely
- Radiator is missing its internal diverter plate not allowing coolant to flow through entire radiator

### Temperature Too Low

- Thermostat stuck open

### Leak at Water Pump Weep Hole

- Faulty water pump mechanical seal (coolant leak)
- Faulty pump shaft oil seal (oil leak)



# CHAPTER 4

## ELECTRONIC FUEL INJECTION

GENERAL INFORMATION .....	4.3
SPECIAL TOOLS .....	4.3
EFI SERVICE NOTES .....	4.5
EFI SYSTEM ASSEMBLY VIEW .....	4.6
EFI SYSTEM COMPONENT LOCATIONS .....	4.7
FUEL TANK .....	4.9
ASSEMBLY VIEW .....	4.9
FUEL LINE REMOVAL / INSTALLATION .....	4.10
FUEL TANK REMOVAL .....	4.10
FUEL TANK INSTALLATION .....	4.12
FUEL TANK REMOVAL RZR XP 4 1000 .....	4.14
FUEL TANK INSTALLATION RZR XP 4 1000 .....	4.15
ELECTRONIC FUEL INJECTION .....	4.16
PRINCIPAL COMPONENTS .....	4.16
EFI OPERATION OVERVIEW .....	4.16
INITIAL PRIMING / STARTING PROCEDURE .....	4.17
ELECTRONIC CONTROL UNIT (ECU) .....	4.17
OPERATION OVERVIEW .....	4.17
ECU SERVICE .....	4.18
ECU REPLACEMENT .....	4.18
FUEL INJECTORS .....	4.19
OPERATION OVERVIEW .....	4.19
FUEL INJECTOR TROUBLESHOOTING .....	4.19
FUEL INJECTOR TEST .....	4.20
FUEL INJECTOR REPLACEMENT .....	4.20
FUEL PUMP .....	4.23
OPERATION OVERVIEW .....	4.23
FUEL SENDER TEST .....	4.24
FUEL PUMP TEST .....	4.24
FUEL PUMP REPLACEMENT .....	4.25
TEMPERATURE / MANIFOLD ABSOLUTE PRESSURE (T-MAP) SENSOR .....	4.29
OPERATION OVERVIEW .....	4.29
T-MAP TEST / REPLACEMENT .....	4.29
CRANKSHAFT POSITION SENSOR (CPS) .....	4.29
OPERATION OVERVIEW .....	4.29
CPS TEST .....	4.30
CPS REPLACEMENT .....	4.30
THROTTLE BODY ASSEMBLY .....	4.31
OPERATION OVERVIEW .....	4.31
THROTTLE BODY SERVICE .....	4.31
THROTTLE BODY REMOVAL .....	4.31
ELECTRONIC THROTTLE CONTROL (ETC) .....	4.32

# ELECTRONIC FUEL INJECTION

---

OPERATION OVERVIEW .....	4.32
ETC TEST .....	4.32
ETC REPLACEMENT .....	4.33
PEDAL POSITION SENSOR (PPS).....	4.33
OPERATION OVERVIEW .....	4.33
LOCATION.....	4.33
PPS TEST .....	4.33
PPS REPLACEMENT .....	4.34
EFI DIAGNOSTICS .....	4.35
INSTRUMENT CLUSTER TROUBLE CODE DISPLAY .....	4.35
EFI TROUBLESHOOTING .....	4.39
DIGITAL WRENCH® OPERATION .....	4.40
DIGITAL WRENCH® DIAGNOSTIC SOFTWARE OVERVIEW.....	4.40
SPECIAL TOOLS (ALSO REFER TO THE BEGINNING OF THIS CHAPTER).....	4.40
DIAGNOSTIC SOFTWARE VERSION .....	4.41
GUIDED DIAGNOSTIC AVAILABLE .....	4.41
DIGITAL WRENCH® COMMUNICATION ERRORS .....	4.41
DIGITAL WRENCH® - DIAGNOSTIC CONNECTOR .....	4.41
DIGITAL WRENCH® SERIAL NUMBER LOCATION .....	4.41
DIGITAL WRENCH® VERSION AND UPDATE ID.....	4.42
DIGITAL WRENCH® UPDATES .....	4.42
DIGITAL WRENCH® FEATURE MAP .....	4.44
ECU REPLACEMENT.....	4.45
ENGINE CONTROLLER REPROGRAMMING (REFLASH).....	4.45

# ELECTRONIC FUEL INJECTION

## GENERAL INFORMATION

### WARNING

- \* Gasoline is extremely flammable and explosive under certain conditions.
- \* EFI components are under high pressure. Verify system pressure has been relieved before disassembly.
- \* Never drain the fuel system when the engine is hot. Severe burns may result.
- \* Do not overfill the tank. The tank is at full capacity when the fuel reaches the bottom of the filler neck. Leave room for expansion of fuel.
- \* Never start the engine or let it run in an enclosed area. Gasoline powered engine exhaust fumes are poisonous and can cause loss of consciousness and death in a short time.
- \* Do not smoke or allow open flames or sparks in or near the area where refueling is performed or where gasoline is stored.
- \* If you get gasoline in your eyes or if you should swallow gasoline, seek medical attention immediately.
- \* If you spill gasoline on your skin or clothing, immediately wash with soap and water and change clothing.
- \* Always stop the engine and refuel outdoors or in a well ventilated area.

## Special Tools

PART NUMBER	TOOL DESCRIPTION	
PU-43506-A	Fuel Pressure Gauge Kit	
PV-48656	Fuel Pressure Gauge Adapter	
PU-47063-B	Digital Wrench® Diagnostic Software (Includes most recent version of software w/serial number, standard interface cable, USB-Serial Adaptor cable and SmartLink Module Kit)	
PU-47471	Digital Wrench® SmartLink Module Kit (PU-47470, PU-47469, PU-47468)	
	PU-47470	Digital Wrench® PC Interface Cable
	PU-47469	Digital Wrench® Vehicle Interface Cable
	PU-47468	Digital Wrench® SmartLink Module

**Bosch Automotive Service Solutions:** 1-800-345-2233 or <http://polaris.service-solutions.com/>

### Fuel Pressure Gauge Kit - PU-43506-A

**NOTE:** The EFI fuel system remains under high pressure, even when the engine is not running. Before attempting to service any part of the fuel system, pressure should be relieved. The Fuel Pressure Gauge Kit has an integrated pressure relief valve that can be used to bleed off pressure once you have completed the fuel pressure test.

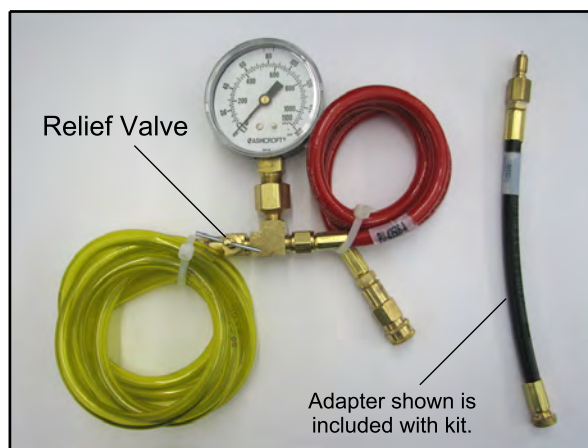

### Fuel Pressure Gauge Adapter - PV-48656

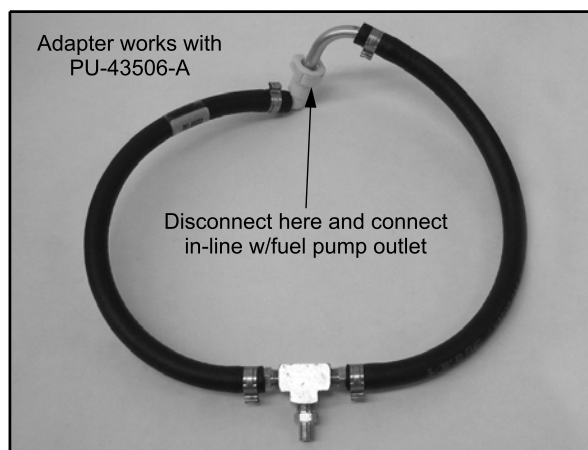

### Digital Wrench® Diagnostic Software - PU-47063-B

This dealer-only software installs on laptop computers equipped with a CD drive and is designed to replace multiple shop tools often used to test EFI components. It also includes step-by-step diagnostic procedures to aid technician repair and troubleshooting.

**NOTE:** If the PC you are using is not equipped with a 9-pin serial port, a USB to serial port adapter will be necessary. A USB to serial port adapter can be purchased through Bosch Automotive Service Solutions (PU-50621) or DSA at: [www.diagsys.com](http://www.diagsys.com)



# ELECTRONIC FUEL INJECTION

## Digital Wrench® SmartLink Module Kit - PU-47471

This module kit contains the necessary cables and hardware to communicate between the vehicle ECU and the Digital Wrench® diagnostic software. Polaris dealers can also order the following kit components separately: **SmartLink Module PU-47468**, **Vehicle Interface Cable PU-47469** and **PC Interface Cable PU-47470**. This module kit is used on all 8 pin connector-based Polaris EFI systems. This kit is available to Polaris dealers through our tool supplier Bosch at <http://polaris.service-solutions.com> or (1-800-345-2233).

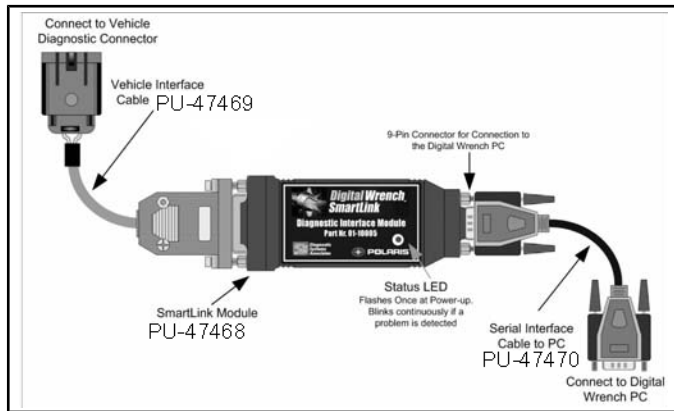

## Digital Wrench® - Diagnostic Connector

Located under the hood connected to a sealed plug.

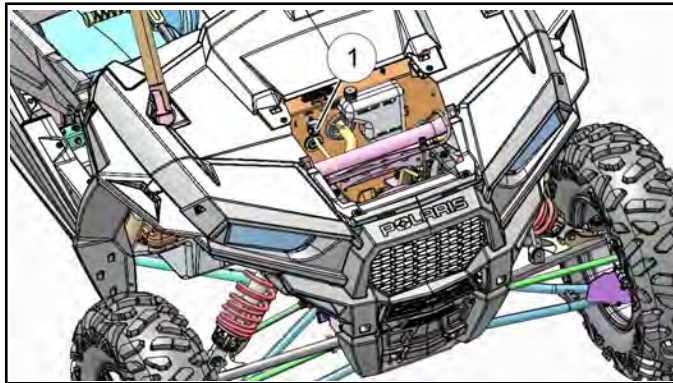

## Digital Wrench® - Download Website

Located at: [www.polaris.diagsys.com](http://www.polaris.diagsys.com)



## Download Digital Wrench® Updates:



**NOTE:** For the most recent information on Digital Wrench® software and update downloads please visit the website: [www.polaris.diagsys.com](http://www.polaris.diagsys.com)

## EFI Service Notes

- For more convenient and accurate testing of EFI components, it is recommended dealers utilize the Digital Wrench® Diagnostic Software (dealer only). Some testing may be done manually using the procedures provided in this chapter.
- **80% of all EFI problems are caused by wiring harness connections.**
- For the purpose of troubleshooting difficult running issues, a known-good ECU from another RZR XP 1000 of the same model and year may be used without damaging system or engine components.
- Never attempt to service any fuel system component while engine is running or ignition switch is "on."
- Cleanliness is essential and must be maintained at all times when servicing or working on the EFI system. Dirt, even in small quantities, can cause significant problems.
- Do not use compressed air if the system is open. Cover any parts removed and wrap any open joints with plastic if they will remain open for any length of time. New parts should be removed from their protective packaging just prior to installation.
- Clean any connector before opening to prevent dirt from entering the system.
- Although every precaution has been taken to prevent water intrusion failure, avoid direct water or spray contact with system components.
- Do not disconnect or reconnect the wiring harness connector to the control unit or any individual components with the ignition "on." This can send a damaging voltage spike through the ECU.
- Do not allow the battery cables to touch opposing terminals. When connecting battery cables attach the positive (red) cable to positive (+) battery terminal first, followed by negative (black) cable to negative (-) battery terminal.
- Never start the engine when the cables are loose or poorly connected to the battery terminals.
- Never disconnect battery while engine is running.
- Never use a battery boost-pack to start the engine.
- Do not charge battery with key switch "on."
- Always disconnect negative (-) battery cable lead before charging battery.
- Always unplug ECU from the wire harness before performing any welding on the unit.

# ELECTRONIC FUEL INJECTION

## EFI System Assembly View

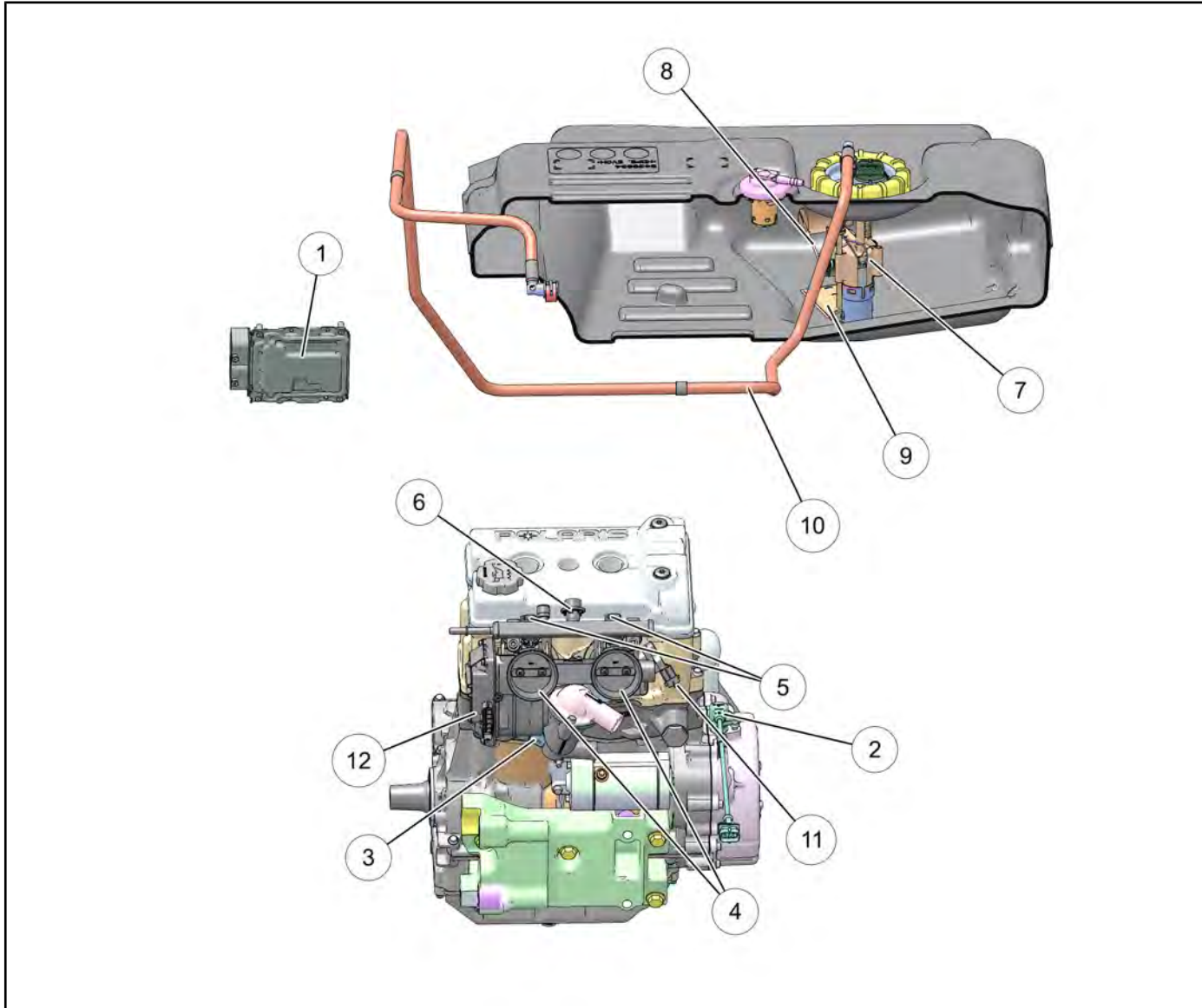

1. Electronic Control Unit (ECU)	7. Fuel Pump / Regulator
2. Crankshaft Position Sensor (CPS)	8. Fuel Level Sender
3. Engine Coolant Temperature Sensor (ECT)	9. Fuel Filter
4. Dual Throttle Body Assembly	10. Fuel Supply Line
5. Fuel Injectors	11. T-MAP Sensor
6. Fuel Rail / Regulator	12. Electronic Throttle Control

# ELECTRONIC FUEL INJECTION

## EFI System Component Locations

- **Electronic Control Unit (ECU)** (Item 1)

Behind driver's seat. Behind LR seat on RZR XP 4 1000.

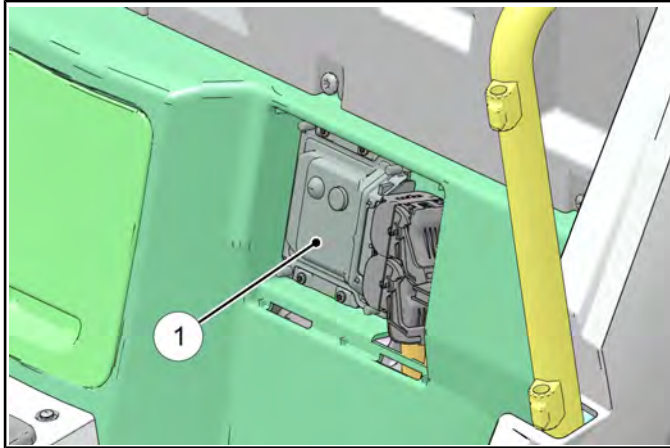

- **Electronic Throttle Control (ETC)** (Item 2)

Located on the PTO side of the throttle body assembly.

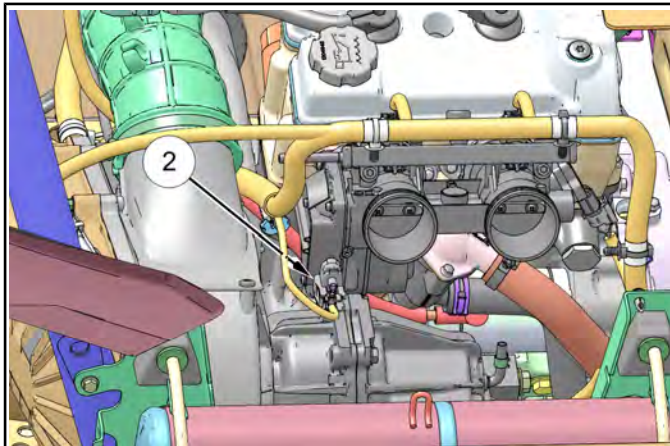

- **Crankshaft Position Sensor (CPS)**(Item 3)

Located on top of the stator cover.

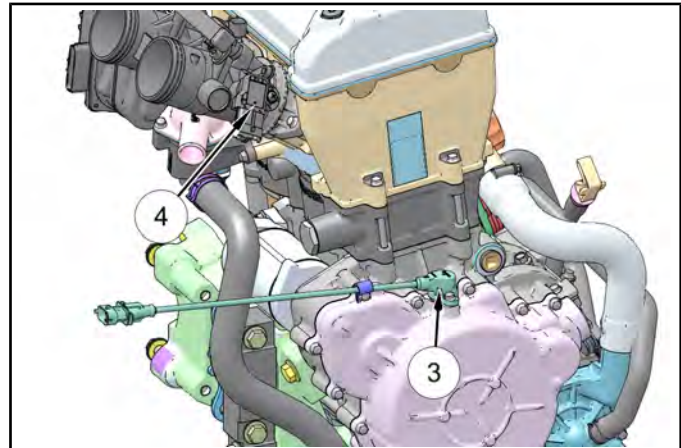

- **Temperature and Manifold Absolute Pressure (TMAP) Sensor** (Item 4)

Located on the Mag side of the throttle body.

- **Engine Coolant Temperature Sensor (ECT)** (Item 5)

Located on the left side of the thermostat housing. The sensor can be accessed with the air box assembly removed.

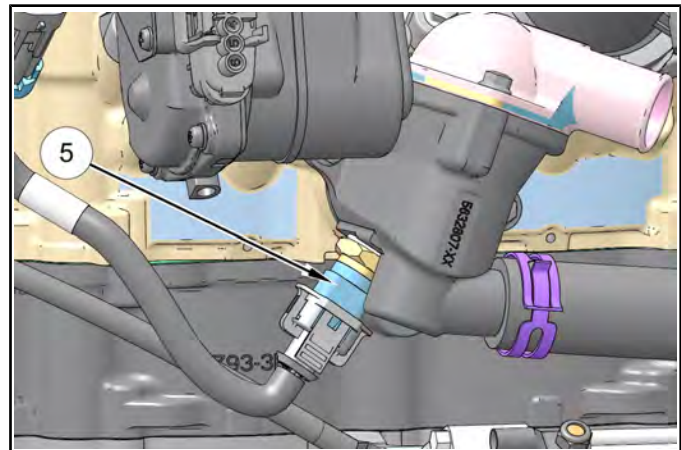

# ELECTRONIC FUEL INJECTION

- **Dual Throttle Body Assembly (Item 6)**

Located between the air box assembly and rubber cylinder head adapters.

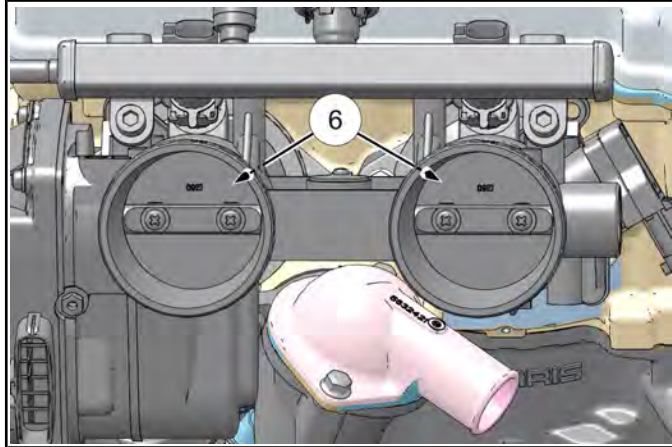

- **Ignition Coil / High Tension Leads (Item 9)**

Located behind the engine service panel on the driver's side of the vehicle.

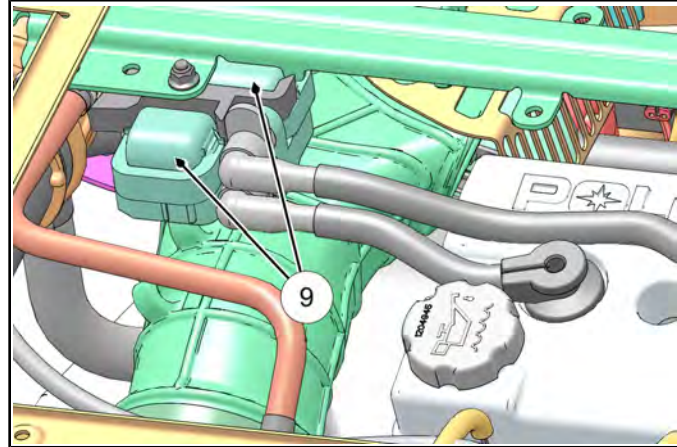

- **Fuel Injectors (Item 7)**

Located on the top of the throttle body in the intake track, retained on top by the fuel rail.

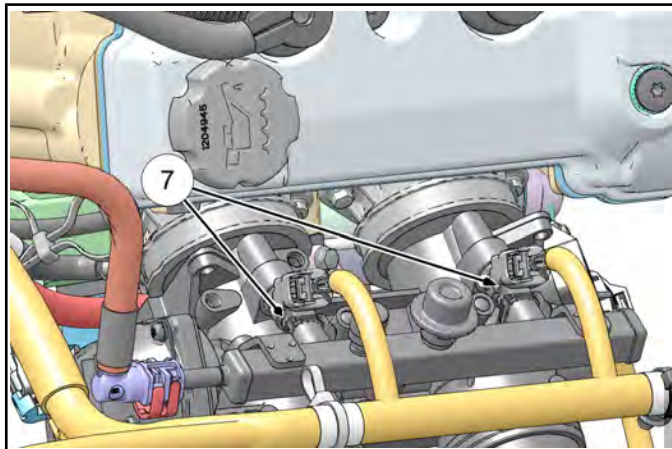

- **Fuel Pump / Regulator / Fuel Sender Assembly (Item 10)**

Under the passenger seat.

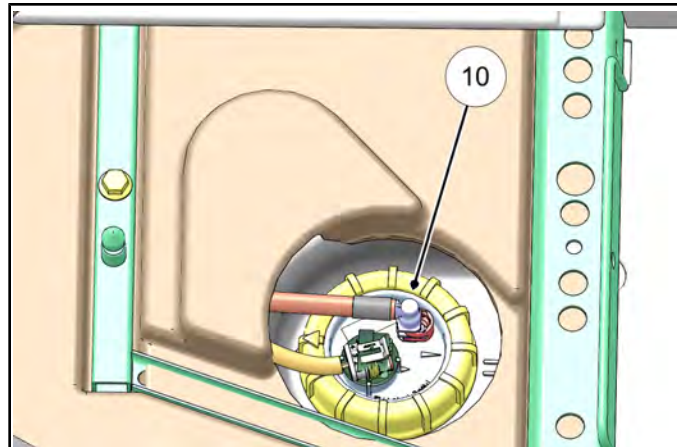

- **Fuel Rail / Regulator (Item 8)**

Located on the throttle body, on top of the fuel injectors.

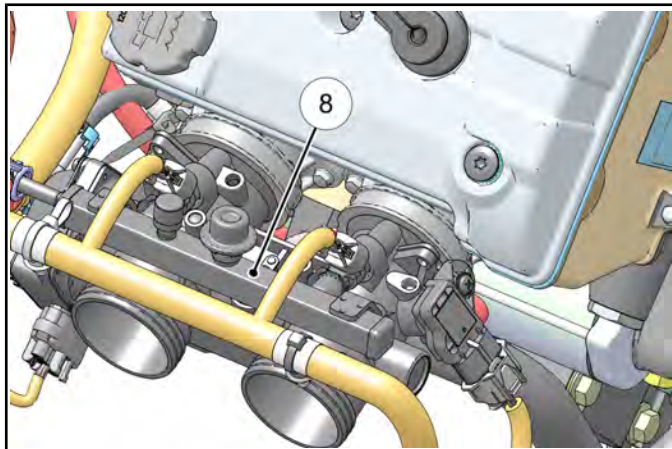

**FUEL TANK**

**Assembly View**

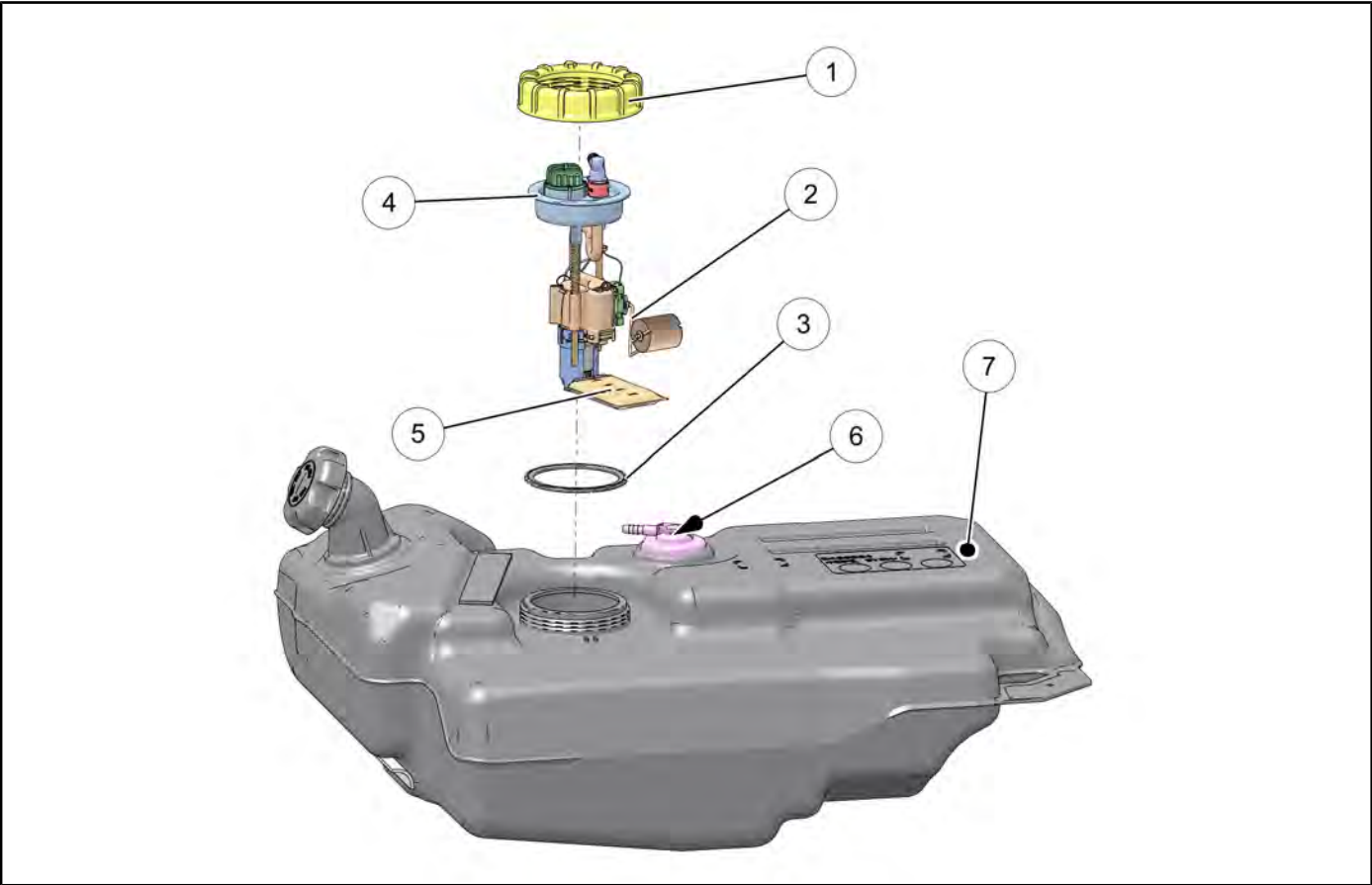

4

1. PFA Nut	5. Preliminary Filter
2. Fuel Sender Float Arm	6. Fuel Tank Vent
3. PFA Gasket (replace if removed)	7. Fuel Tank Assembly
4. Fuel Pump / Regulator	

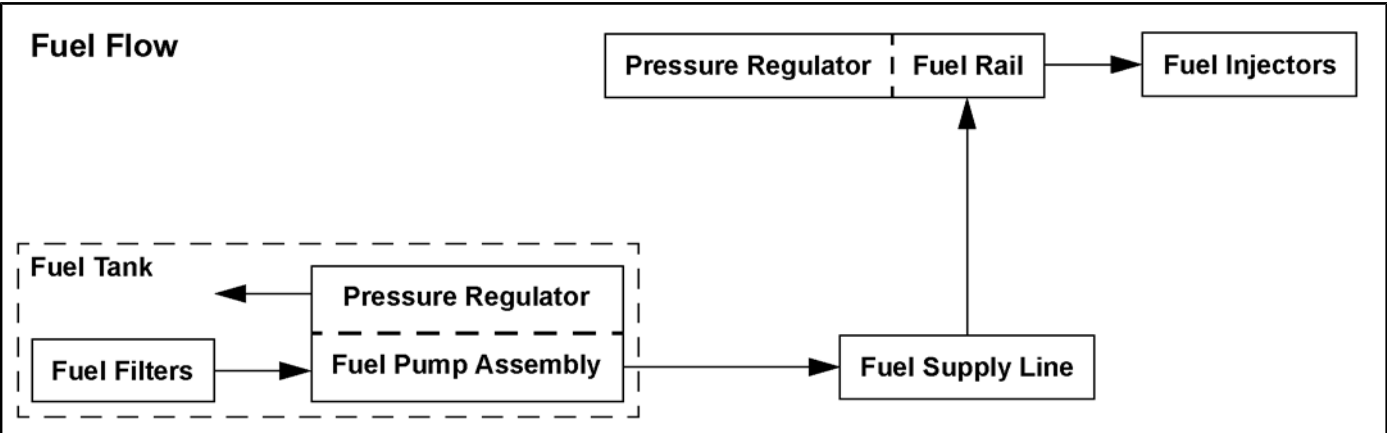

# ELECTRONIC FUEL INJECTION

## Fuel Line Removal / Installation

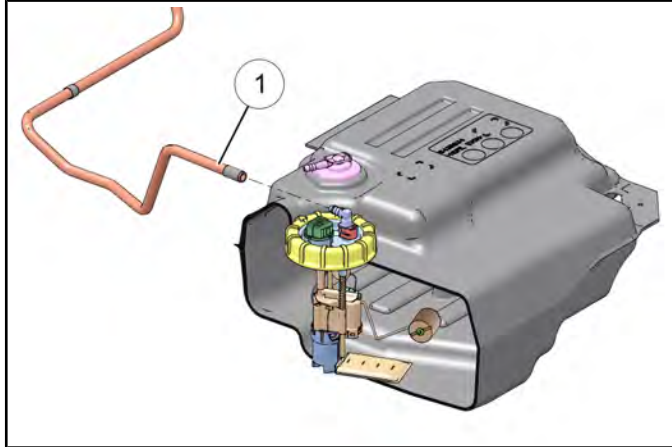

1. Place a shop towel around the fuel line to catch any dripping fuel.
2. If removing either end of supply line (Item 2), pull open tabs while moving green connector out to release the line.

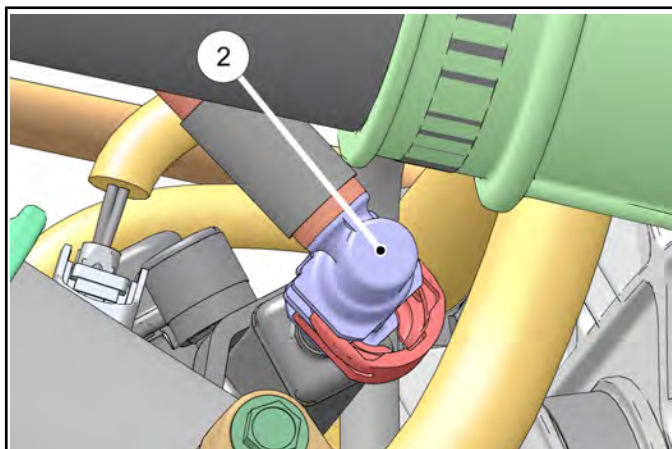
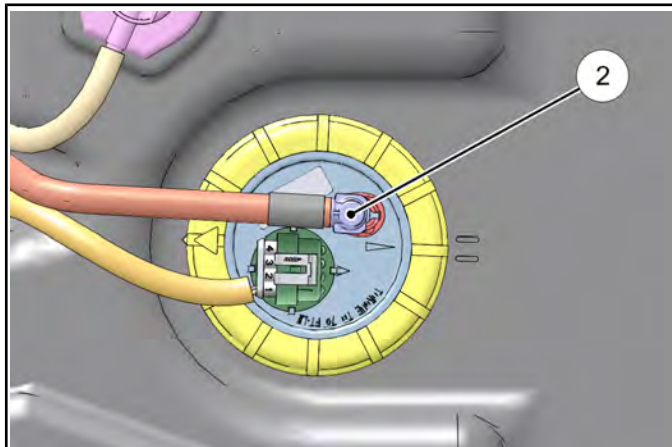

3. Pull on the fuel line for removal.
4. To install the line, verify the connections are clean and free of debris.

5. Place the fuel line back over the fitting and slide the green connector locking mechanism back into place. Verify the connector tabs snap back into place.
6. Be sure fuel line is routed and retained properly.

## Fuel Tank Removal

**NOTE:** Syphon as much fuel from the tank as possible before attempting to remove it from the vehicle.

### **WARNING**

Always wear safety goggles when working with high pressure or flammable fluids. Failure to do so could result in serious injury or complications.

1. Remove the driver and passenger seats.
2. Disconnect the negative and positive battery cables from the battery, located under the driver's seat. Remove the bolt retaining the battery bracket and remove the battery from the vehicle.
3. While holding a shop towel over the fuel line connectors, disconnect the fuel supply line (Item 1) from the pump (see "Fuel Lines - Quick Connect Fittings" for specific removal procedure).

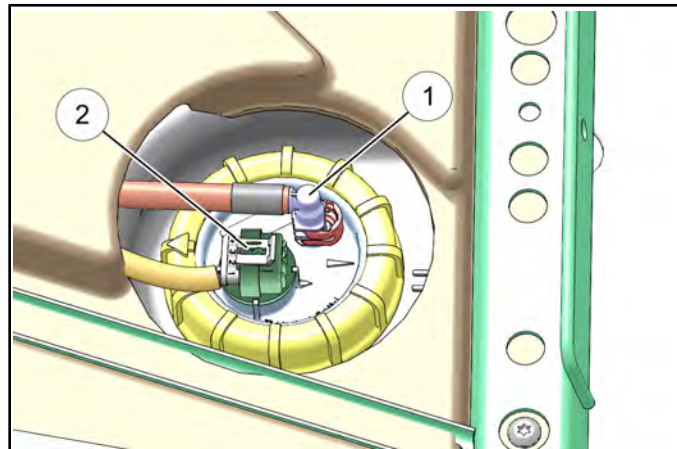

**NOTE:** A small amount of fuel may come out of the fuel lines or pump fitting. Properly drain fuel into a suitable container.

4. Disconnect the fuel pump electrical harness (Item 2).

## 4.10

## ELECTRONIC FUEL INJECTION

5. Remove the push rivets and Torx screws retaining the right-hand rocker panel using the multi-function pliers and a T40 Torx driver. Remove the rocker panel (Item 4) from the vehicle.

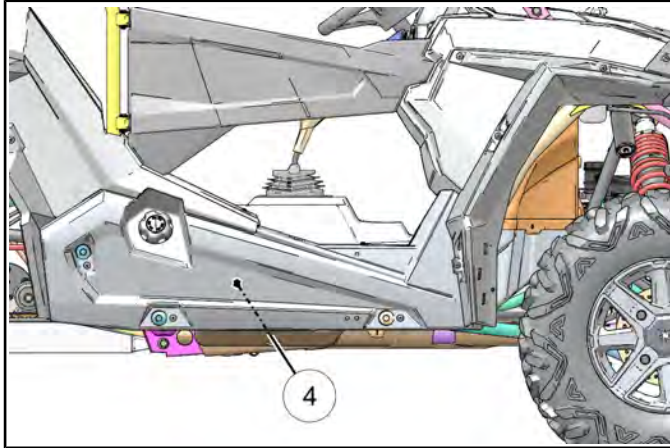

6. Remove the fastener (Item 5) retaining the seat belt mechanism to the frame near the right rear portion of the fuel tank. Once removed, place the mechanism in the rear cargo box to keep it out of the way.

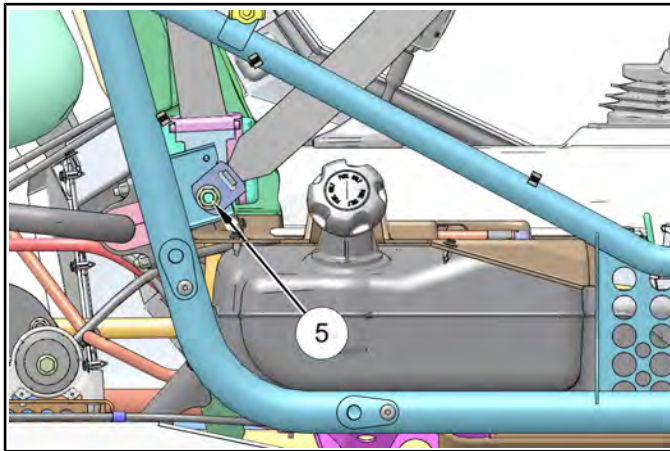

7. Remove the shift knob (Item 6) using a flat blade screwdriver and T25 Torx driver. Remove the Torx screws retaining the center console. Remove the console from the vehicle.

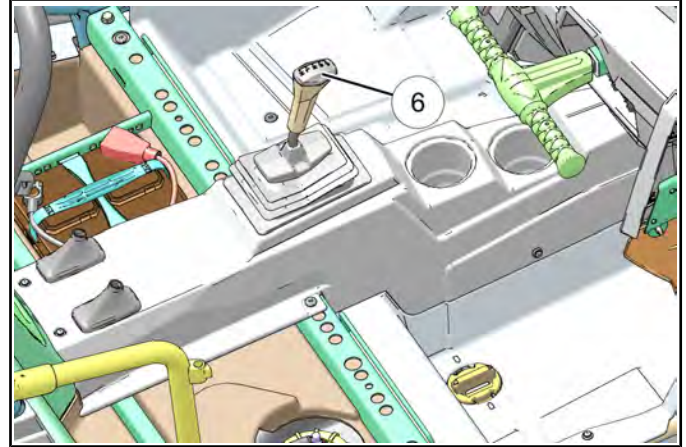

4

8. Remove the shift linkage from the shifter.
9. Remove the two bolts (Item 7) and two T40 Torx screws (Item 9) retaining the front of the seat base frame and two rear bolts (Item 8). Remove the rear seat base assembly from the vehicle.

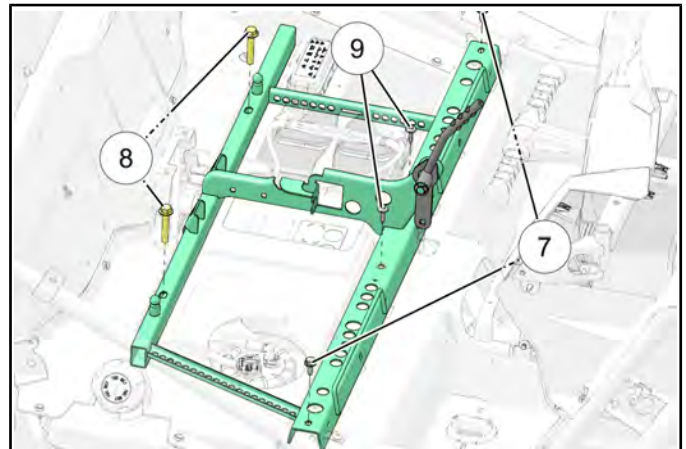



## ELECTRONIC FUEL INJECTION

10. Remove the T-40 Torx screw (Item 10) retaining the fuel tank strap to the seat base frame. Remove the strap from the other side of the seat base frame as well.

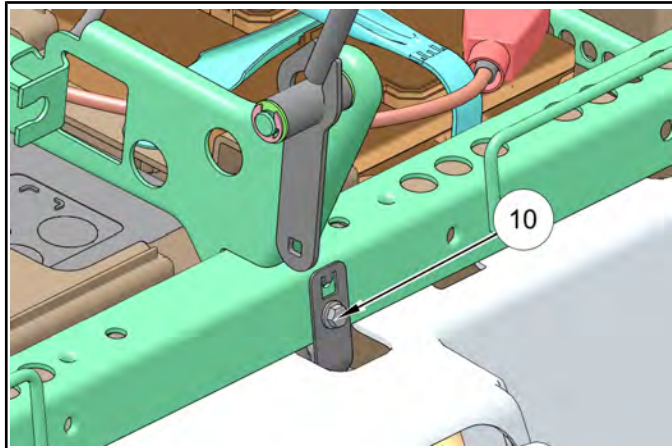

11. Remove the Torx screws (Item 11) and plastic rivets (Item 12) retaining the block-off panel using a T40 Torx driver. Remove the panel from the vehicle.

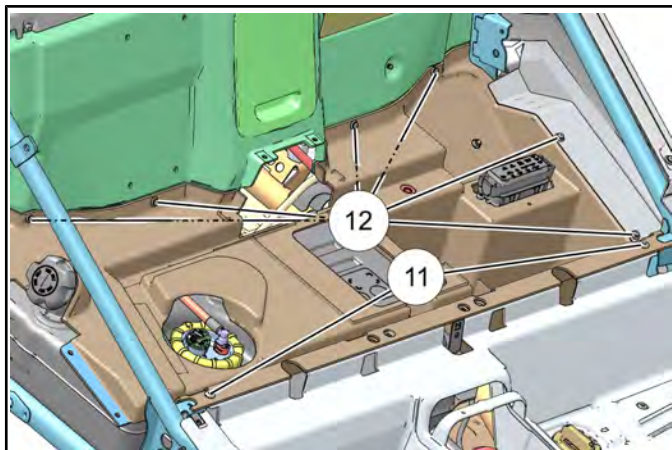

12. Remove the nuts (Item 13) retaining the regulator and Torx screws (Item 14) retaining the fuse box.

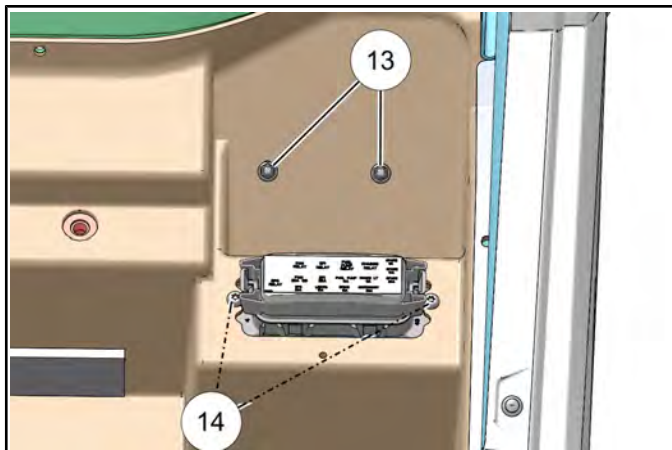

13. Remove the fuel tank vent line from the tank fitting.

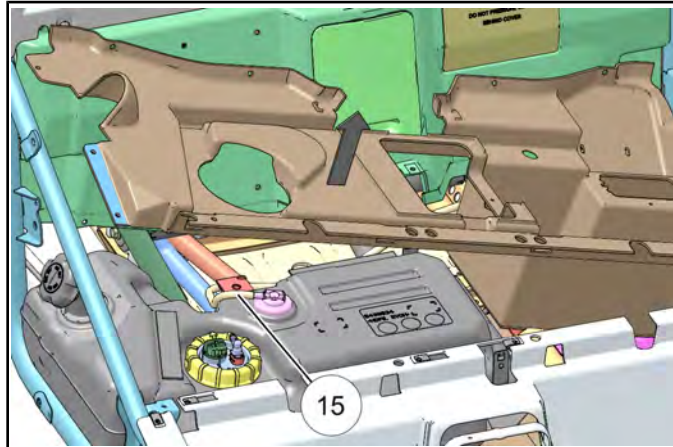

14. Lift the rear of the fuel tank up first. Carefully pull the fuel tank out of the vehicle.

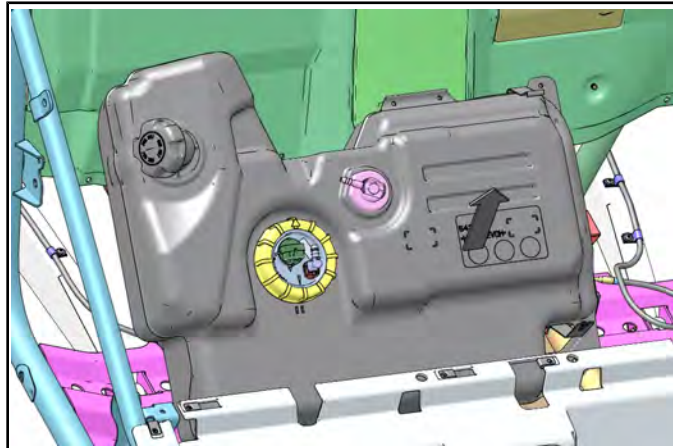

### Fuel Tank Installation

1. Carefully reinstall the fuel tank assembly. Install the inner tank bracket with the fuel tank to ensure the bracket is inserted properly into the lower fuel tank mount.
2. Reinstall the fuel tank bracket and fasteners.
3. Install the vent line.
4. Reinstall block-off panel. Secure with plastic rivets and torque screws to specification.



Block-off Panel Screws  
8 ft-lbs (11 Nm)

## ELECTRONIC FUEL INJECTION

5. Reinstall the seat base frame and torque fasteners to specification.

 = T
Seat Base Frame fasteners <b>8 ft-lbs (11 Nm)</b>

6. Install regulator and fuse box to the block-off panel. Torque fasteners to specification.

 = T
Regulator/Fuse Box fasteners <b>5 ft-lb (7 Nm)</b>

7. Install fuel tank strap screw. Torque screw to specification.

 = T
Fuel Tank Strap Screw <b>8 ft-lbs (11 Nm)</b>

8. Reinstall center console, shift knob and screws.  
9. Reinstall seat belt mechanism. Torque bolt to specification.

 = T
Seat Belt Mechanism Bolt: <b>40 ft-lbs (54 Nm)</b>

10. Reinstall right rocker panel and all previously removed fasteners.  
11. Reconnect the fuel line and fuel pump electrical harness. Verify connections are secure.  
12. Reinstall the battery and battery bracket. Torque fastener to specification.

 = T
Battery Bracket: <b>8 ft-lbs (11 Nm)</b>

13. Install both seats and test the fuel pump by turning the ignition key on and listening for the pump to activate. Check the fuel line fittings for leaks.

# ELECTRONIC FUEL INJECTION

## Fuel Tank Removal RZR XP 4 1000

### WARNING

Always wear safety goggles when working with high pressure or flammable fluids. Failure to do so could result in serious injury or complications.

**NOTE:** Syphon as much fuel from the tank as possible before attempting to remove it from the vehicle.

1. Remove the front and rear seats.
2. Disconnect the negative and positive battery cables from the battery, located under the left rear seat. Remove the bolt retaining the battery bracket and remove the battery from the vehicle.
3. While holding a shop towel over the fuel line connectors, disconnect the fuel supply line (Item 1) from the pump (see "Fuel Lines - Quick Connect Fittings" for specific removal procedure).

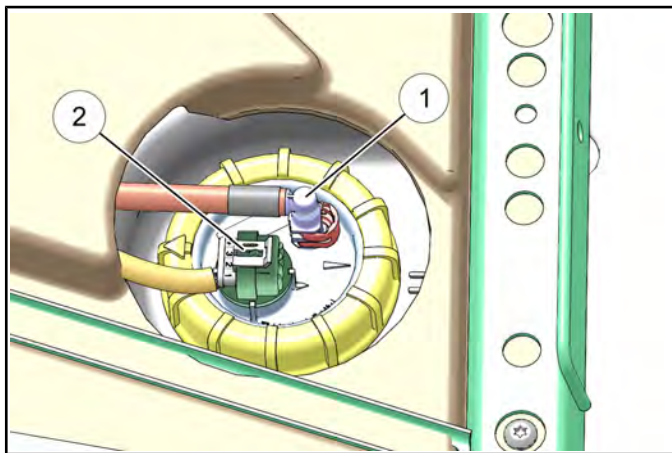

**NOTE:** A small amount of fuel may come out of the fuel lines or pump fitting. Properly drain fuel into a suitable container.

4. Disconnect the fuel pump electrical harness (Item 2).
5. Remove the right-hand rocker panel (see Chapter 5).
6. Remove the fastener (Item 3) retaining the seat belt mechanism to the frame near the right rear portion of the fuel tank. Once removed, place the mechanism in the rear cargo box to keep it out of the way.

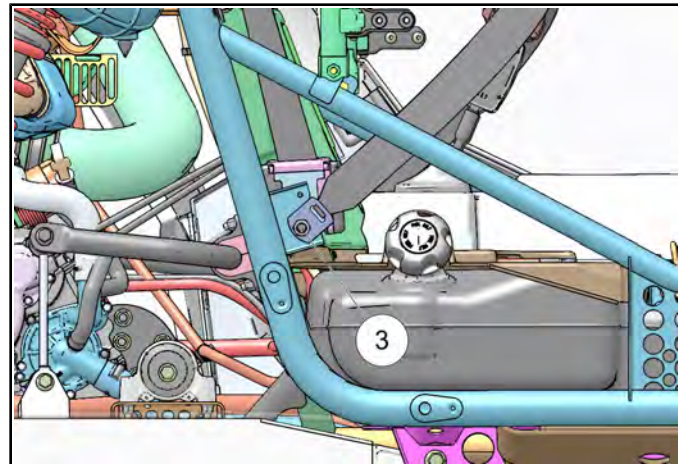

7. Remove the front and rear console assembly (see Chapter 5).
8. Remove the two M10x1.5x55 bolts (Item 4) and two M8x1.25x20 bolts (Item 5) retaining the front of the rear seat base frame. Remove the rear seat base assembly from the vehicle.

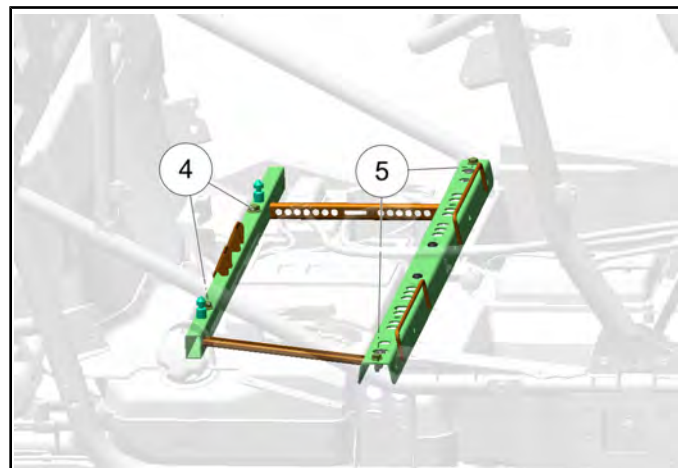

9. Remove the T-40 Torx screw (Item 6) retaining the fuel tank strap to the seat base frame. Remove the strap from the other side of the seat base frame as well.

## ELECTRONIC FUEL INJECTION

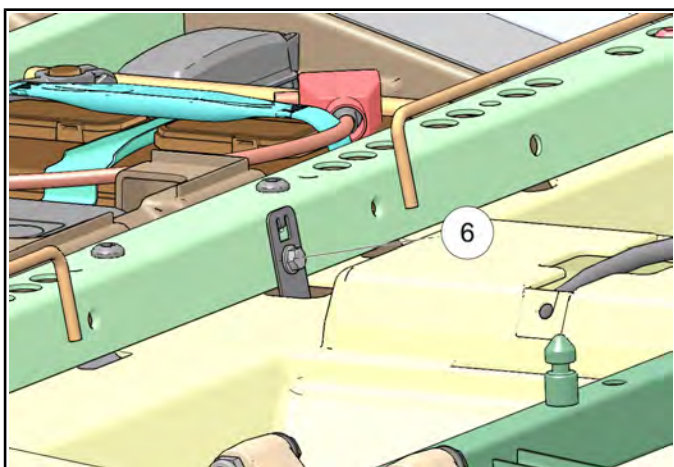

10. Remove the Torx screws (Item 7) and push rivets (Item 8) retaining the lower rear close-off panel using a T40 Torx driver. Remove the panel from the vehicle.

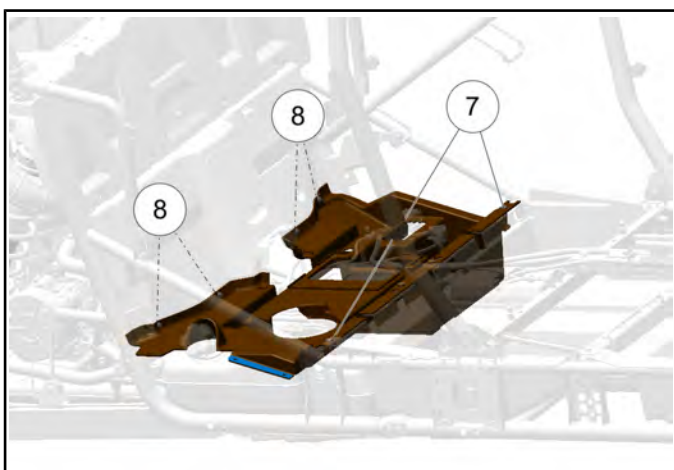

11. Remove the nuts (Item 9) retaining the regulator and bolts (Item 10) retaining the fuse box.

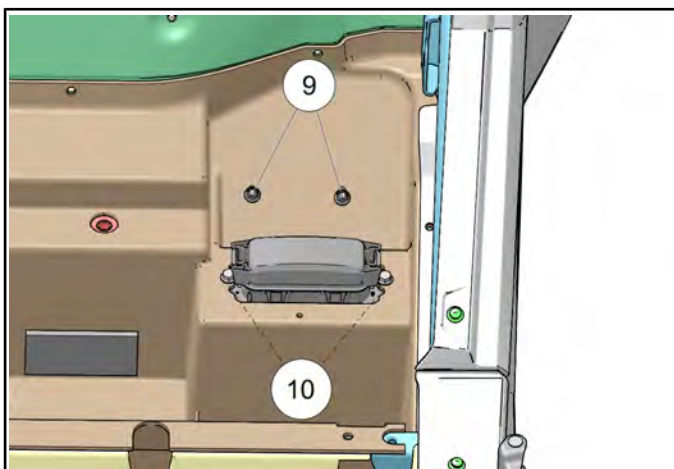

12. Remove the fuel tank vent line (Item 11) from the tank fitting.

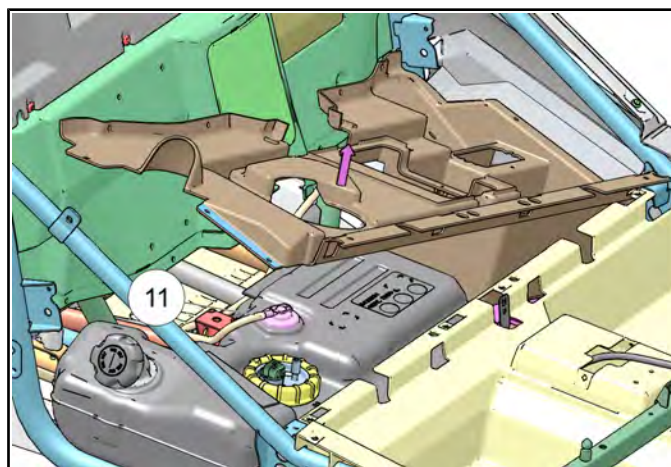

13. Lift the rear of the fuel tank up first. Carefully pull the fuel tank out of the vehicle.

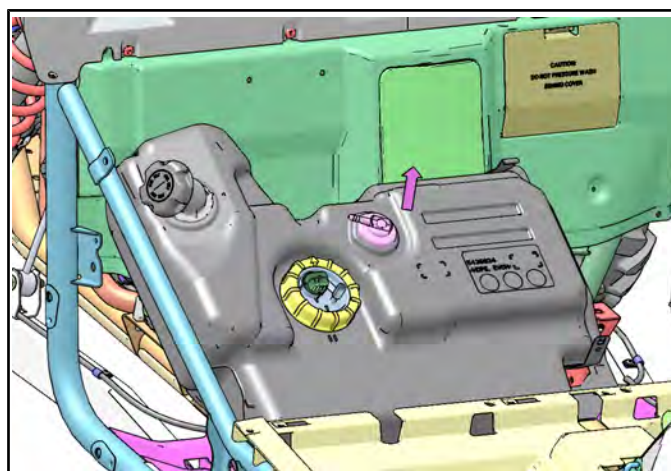

### Fuel Tank Installation RZR XP 4 1000

1. Carefully reinstall the fuel tank assembly. Install the inner tank bracket with the fuel tank to ensure the bracket is inserted properly into the lower fuel tank mount.
2. Reinstall the fuel tank bracket and fasteners.
3. Install the vent line.
4. Reinstall lower rear close-off panel. Secure with plastic rivets and torque screws to specification.



= T

Block-off Panel Screws  
8 ft-lbs (11 Nm)

5. Reinstall the seat base frame and torque fasteners to specification.

4

## ELECTRONIC FUEL INJECTION

---



Seat Base Frame fasteners  
**8 ft-lbs (11 Nm)**

6. Install regulator and fuse box to the block-off panel. Torque fasteners to specification.



Regulator/Fuse Box fasteners  
**5 ft-lb (7 Nm)**

7. Install fuel tank strap screw. Torque screw to specification.



Fuel Tank Strap Screw  
**8 ft-lbs (11 Nm)**

8. Reinstall rear and front center console, shift knob and screws.  
9. Reinstall seat belt mechanism. Torque bolt to specification.



Seat Belt Mechanism Bolt:  
**40 ft-lbs (54 Nm)**

10. Reinstall right rocker panel and all previously removed fasteners.  
11. Reconnect the fuel line and fuel pump electrical harness. Verify connections are secure.  
12. Reinstall the battery and battery bracket. Torque fastener to specification.



Battery Bracket:  
**8 ft-lbs (11 Nm)**

13. Install seats and test the fuel pump by turning the ignition key on and listening for the pump to activate. Check the fuel line fittings for leaks.

## ELECTRONIC FUEL INJECTION

### Principal Components

The Electronic Fuel Injection (EFI) system is a complete engine fuel and ignition management design. This system includes the following principal components:

- Check Engine Light
- Crankshaft Position Sensor (CPS)
- Dual Throttle Body / Intake Adapter
- Engine Control Unit (ECU)
- Engine Coolant Temperature Sensor (ECT)
- Fuel Filter(s)
- Fuel Injectors
- Fuel Pressure Regulators
- Fuel Pump
- Fuel Rail
- Fuel Supply/Return Lines
- Idle Air Control Valve (IAC)
- Ignition Coil
- Manifold Air Quality Sensor (MAQS)
- Wire Harness Assembly

### EFI Operation Overview

The EFI system is designed to provide peak engine performance with optimum fuel efficiency and lowest possible emissions. The ignition and injection functions are electronically controlled, monitored and continually corrected during operation to maintain peak performance.

The central component of the system is the Bosch ME17 Electronic Control Unit (ECU) which manages system operation, determining the best combination of fuel mixture and ignition timing for the current operating conditions.

An electric fuel pump is used to move fuel from the tank, through the fuel supply line, to the fuel rail. Fuel pressure regulators located in the tank and on the end of the fuel rail, maintain system operating pressure and return excess fuel back into the fuel tank. At the engine, fuel fed through the fuel rail supplies fuel to the injectors, which inject into the intake ports. The ECU controls the amount of fuel by varying the length of time that the injectors are "on." This range can vary depending on fuel requirements. The controlled injection of the fuel occurs every other crankshaft revolution, or once for each 4-stroke cycle. When the intake valve opens, the fuel/air mixture is drawn into the combustion chamber, ignited and burned.

# ELECTRONIC FUEL INJECTION

The ECU controls the amount of fuel being injected and the ignition timing by monitoring the primary sensor signals for intake air temperature, manifold absolute pressure (load), engine temperature, engine speed (RPM) and throttle position. These primary signals are compared to the programming in the ECU computer chip, and the ECU adjusts the fuel delivery and ignition timing based on these values.

During operation, the ECU has the ability to re-adjust temporarily; providing compensation for changes in overall engine condition and operating environment, so it will be able to maintain the ideal air/fuel ratio.

During certain operating periods such as cold starts, warm up, acceleration, etc., a richer air / fuel ratio is automatically calculated by the ECU.

## Initial Priming / Starting Procedure

**NOTE: The injection system must be purged of all air prior to the initial start up, and / or any time the system has been disassembled.**

If the EFI system is completely empty of fuel or has been disassembled and repaired:

1. Cycle the key switch from "OFF" to "ON" 6 times, waiting for approximately 3 seconds at each "ON" cycle to allow the fuel pump to cycle and shut down.
2. Once step 1 is completed, turn the key switch to "START" until the engine starts or 5 seconds has passed.
3. If the engine failed to start, repeat step 1 for 2 more cycles and attempt to start the engine.

If the engine fails to start, a problem may still exist, and should be diagnosed.

**NOTE: Accurate testing of EFI components is recommended utilizing the Digital Wrench® Diagnostic Software (dealer only).**

## ELECTRONIC CONTROL UNIT (ECU)

### Operation Overview

The ECU (Item 1) is the brain or central processing computer of the entire EFI fuel/ignition management system. During operation, sensors continuously gather data which is relayed through the wiring harness to input circuits within the ECU. Signals to the ECU include: ignition power (on/off), intake air temperature, manifold absolute pressure (load), engine coolant temperature, crankshaft position and engine speed (RPM), throttle position and battery voltage. The ECU compares the input signals to the programmed maps in its memory and determines the appropriate fuel and ignition requirements for the immediate operating conditions. The ECU then sends output signals to set injector duration and ignition timing.

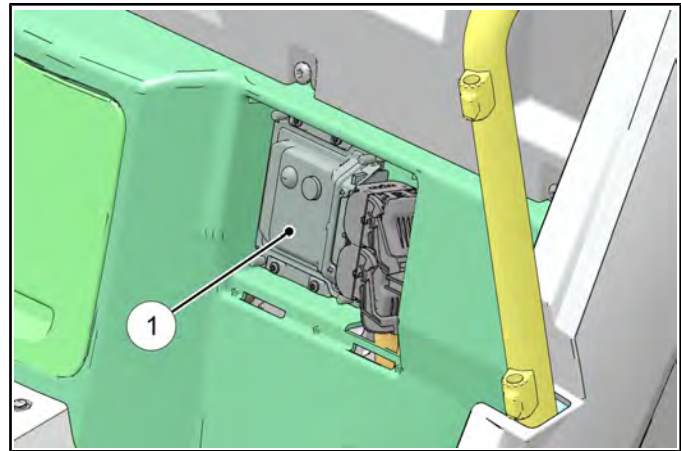

During operation, the ECU continually performs a diagnostic check of itself, each of the sensors, and system performance. If a fault is detected, the ECU turns on the "Check Engine" light on the instrument cluster and stores the fault code in its fault memory. Depending on the significance or severity of the fault, normal operation may continue, or "Fail-Safe" operation (slowed speed, richer running) may be initiated. A technician can determine the cause of the "Check Engine" light by referencing the "Instrument Cluster Trouble Code Display" and "Diagnostic Trouble Code Table" or by using Digital Wrench®. The ECU requires a minimum of 7.0 volts to operate. The memory in the ECU is operational the moment the battery cables are connected.

To prevent engine over-speed and possible failure, an RPM limiting feature is programmed into the ECU. If the maximum RPM limit is exceeded, the ECU suppresses the injection signals, cutting off the fuel flow and retards the ignition timing. This process repeats itself in rapid succession, limiting operation to the preset maximum.

**RPM Limit: 8800**

4

# ELECTRONIC FUEL INJECTION

## ECU Service

Never attempt to disassemble the ECU. It is sealed to prevent damage to internal components. Warranty is void if the case is opened or tampered with in any way.

All operating and control functions within the ECU are pre-set. No internal servicing or readjustment may be performed. If a problem is encountered, and you determine the ECU to be faulty, contact the Polaris Service Department for specific handling instructions. Do not replace the ECU without factory authorization.

For the purpose of troubleshooting, a known-good ECU from another Polaris **RZR XP 1000** of the same model may be used without system or engine component damage.

## ECU Replacement

Although the need for ECU replacement is unlikely, a specific replacement procedure is required to ensure that all essential data contained within the original ECU is transferred to the replacement ECU.

**NOTE: Refer to this procedure and carefully follow all instructions provided in Digital Wrench®.**

1. Carefully follow the ECU replacement instructions provided in Digital Wrench® to ensure that all essential data contained within the original ECU is transferred to the replacement ECU.
2. Remove the black plastic cover by lifting up on the tab. Remove the retaining screw that attaches the ECU to the left rear fender well.

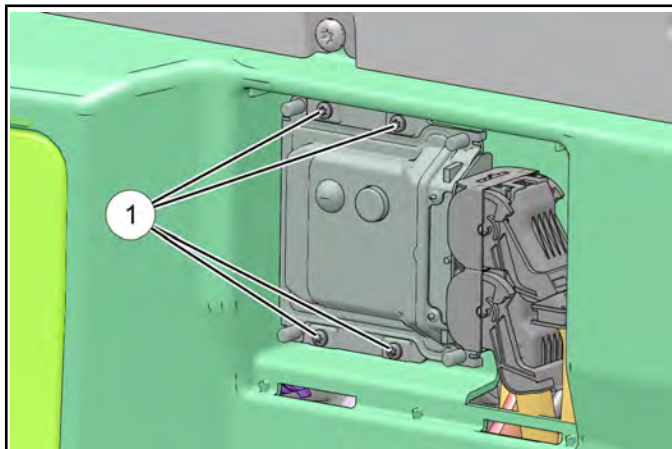

3. With the ignition turned off, disconnect the wire harness from the ECU. Lift the connector locking lever and rotate it up until the connector is free from the ECU.

**NOTE: Upon removing the ECU connector, you should hear a “click” when the connector is fully open.**

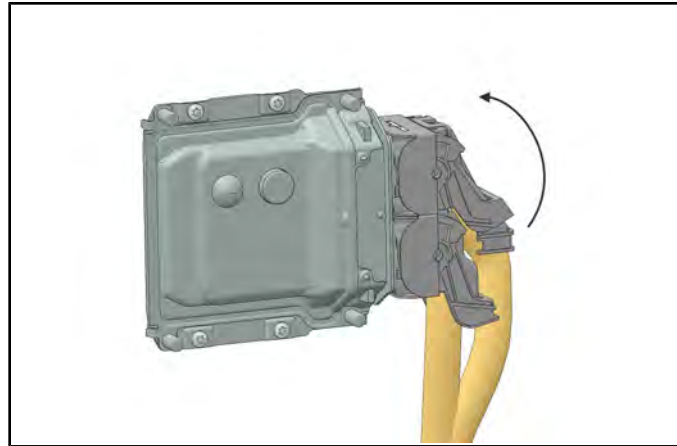

4. To install, reverse the procedure and tighten the mounting screws to specification.

**NOTE: Upon installing the ECU connector, you should hear a “click” when the connector is fully closed.**



ECU Retaining Screws:  
**24 in-lb (3 Nm)**

# ELECTRONIC FUEL INJECTION

## FUEL INJECTORS

### Operation Overview

The fuel injectors (Item 2) are mounted into the dual throttle body assembly, with the fuel rail (Item 1) retaining them from the top end. O-rings on both ends of the injector prevent external fuel leaks and also insulate the injectors from heat and vibration.

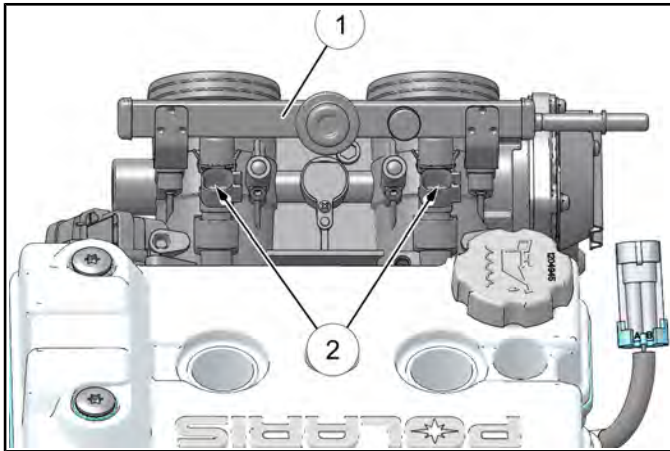

When the key switch is on, the fuel rail is pressurized, and the EFI relay provides voltage to the injectors. During engine operation, the ECU completes the ground circuit, energizing the injectors. The valve needle in each injector is opened electromagnetically, and the pressure in the fuel rail forces fuel down through the inside. The “director plate” at the tip of the injector contains a series of calibrated openings which directs the fuel into the intake port in a cone-shaped spray pattern.

The amount of fuel injected is controlled by the ECU and determined by the length of time the valve needle is held open, also referred to as the “injection duration” or “pulse width”. It may vary in length depending on the speed and load requirements of the engine.

The ECU gathers fuel injection timing information from the Crankshaft Position Sensor (CPS) and the Manifold Air Quality Sensor (MAQS) to allow for sequential fuel injection.

### Fuel Injector Troubleshooting

Injector problems typically fall into three general categories- electrical, dirty / clogged, or leakage. An electrical problem usually causes one or both of the injectors to stop functioning. Several methods may be used to check if the injectors are operating.

- With the engine running at idle, feel for operational vibration, indicating that they are opening and closing.
- When temperatures prohibit touching, listen for a buzzing or clicking sound with a screwdriver or mechanic's stethoscope.
- Disconnect the electrical connector from an injector and listen for a change in idle performance (only running on one cylinder) or a change in injector noise or vibration.

**NOTE: Do not apply voltage directly to the fuel injector(s). Excessive voltage will burn out the injector(s). Do not ground the injector(s) with the ignition on. Injector(s) will open/turn on if relay is energized.**

If an injector is not operating, it can indicate either a bad injector, or a wiring/electrical connection problem. Check as follows:

Injector leakage is very unlikely, but in rare instances it can be internal (past the tip of the valve needle), or external (weeping around the injector body). The loss of system pressure from the leakage can cause hot restart problems and longer cranking times.

Injector problems due to dirt or clogging are unlikely due to the design of the injectors, the high fuel pressure, the use of filters and the detergent additives in the gasoline. Symptoms that could be caused by dirty/clogged injectors include rough idle, hesitation/stumble during acceleration, or triggering of fault codes related to fuel delivery. Injector clogging is usually caused by a buildup of deposits on the director plate, restricting the flow of fuel, resulting in a poor spray pattern. Some contributing factors to injector clogging include; dirty air filters, higher than normal operating temperatures, short operating intervals and dirty, incorrect, or poor quality fuel. Cleaning of clogged injectors is not recommended; they should be replaced. Additives and higher grades of fuel can be used as a preventative measure if clogging has been a problem.



# ELECTRONIC FUEL INJECTION

## Fuel Injector Test

**NOTE:** Take note of PTO and MAG fuel injector harness connectors before disconnecting them. The harness leads are marked with PTO and MAG identifiers.

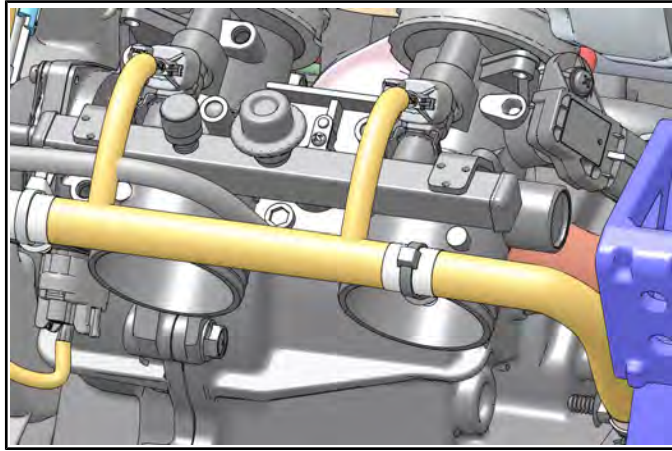

The fuel injectors are non-serviceable. If diagnosis indicates a problem with either injector, test the resistance of the fuel injector(s) by measuring between the two pin terminals (Item 1):

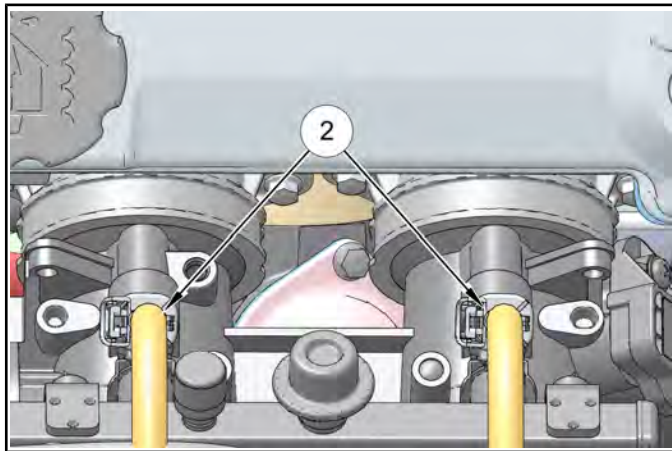

**Fuel Injector Resistance Specification:**  
11.4 - 12.6  $\Omega$

**NOTE:** Be sure to connect the PTO harness lead to the PTO injector and the MAG harness lead to the MAG injector to ensure proper engine operation.

## Fuel Injector Replacement

1. Remove the cargo box assembly (see chapter 5).
2. Be sure the engine has cooled enough to work on.

3. Loosen the hose clamps (Item 1) retaining the intake plenum (Item 2) to the throttle body.

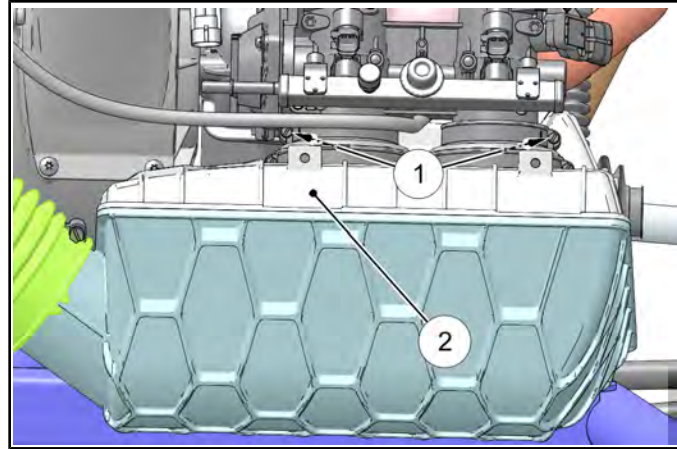

4. Remove the two screws (Item 3) retaining the intake plenum.

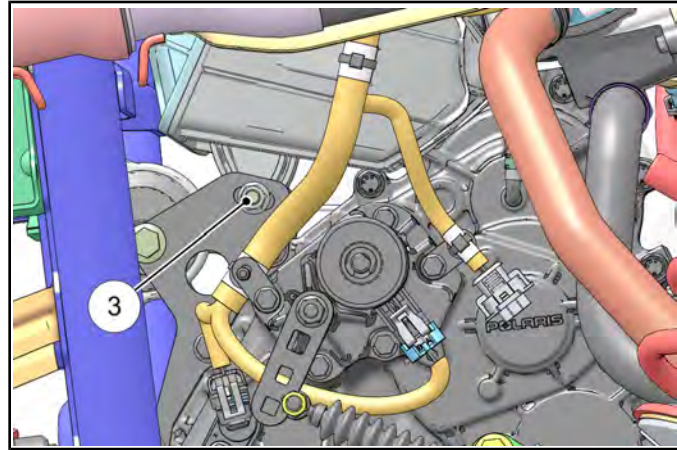

5. Remove the driver's seat and disconnect the negative battery cable.
6. Disconnect the fuel injector harness leads (Item 4).

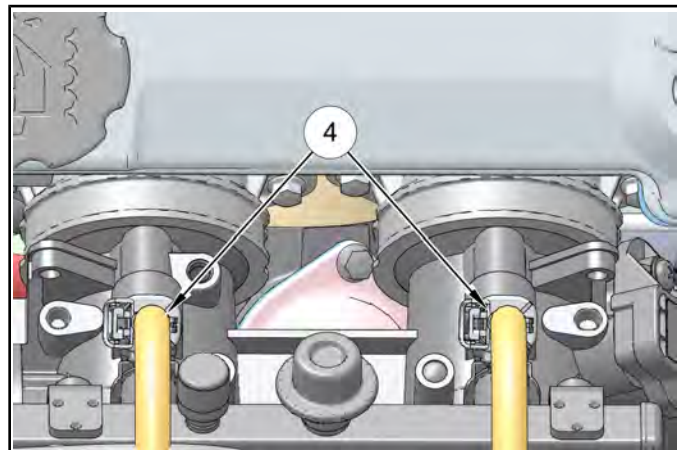

## ELECTRONIC FUEL INJECTION

7. Hold a shop towel over the fuel line fitting and remove the fuel supply line (Item 5) from the fuel rail.

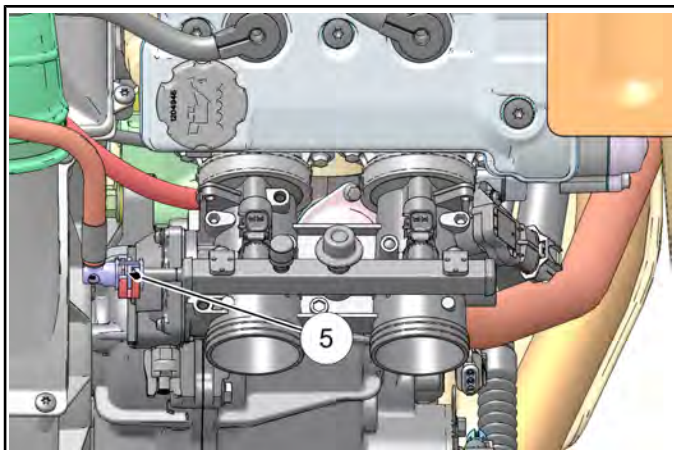

8. Remove tie strap retaining the injector harness leads to the fuel rail. Remove the two screws (Item 6) that mount the fuel rail to the throttle body using a 5 mm Allen wrench.

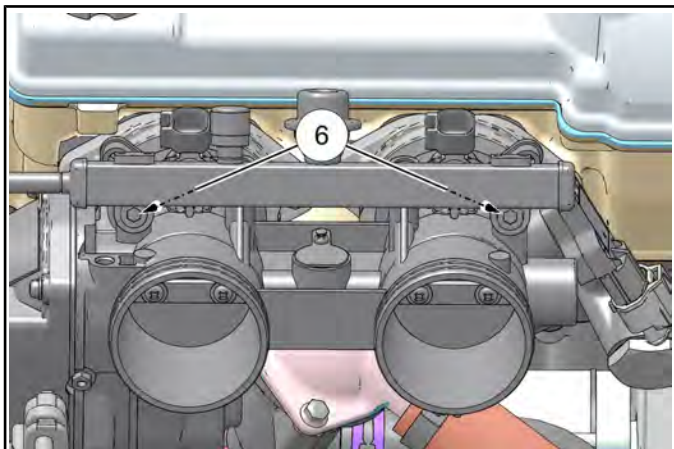

9. Carefully pull up on the fuel rail (Item 7) and injectors and remove them from the throttle body as an assembly. Take care not to damage the fuel injector ends during removal.

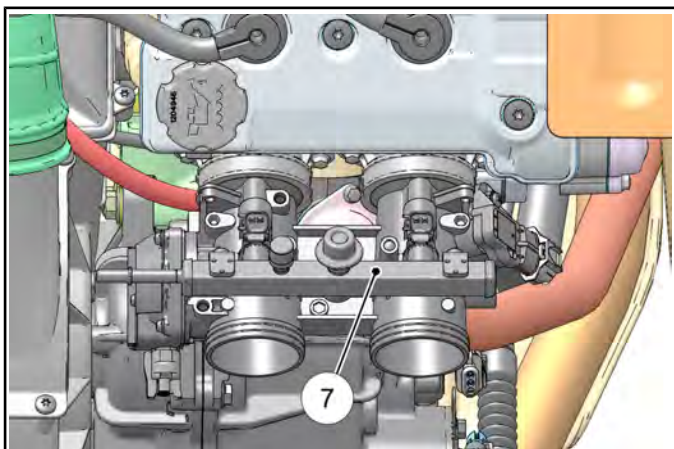

10. Pull out on the fuel injector retaining clip and pull the injector out of the fuel rail. Repeat on the other injector if removal is necessary.

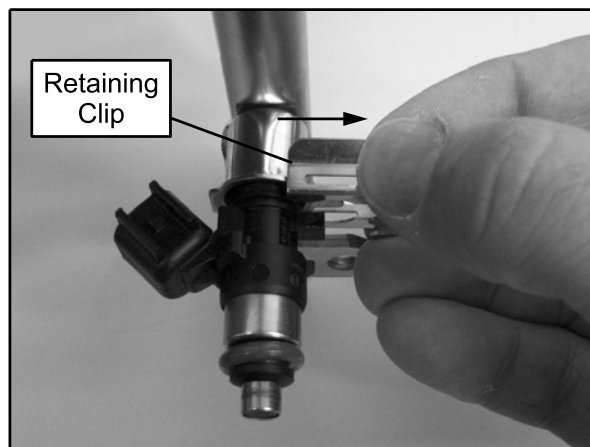

4

11. Upon installation of the new fuel injectors, lightly lubricate the injector O-rings to aid installation.
12. Install the new injector (s) into the fuel rail and reinstall the retaining clip.

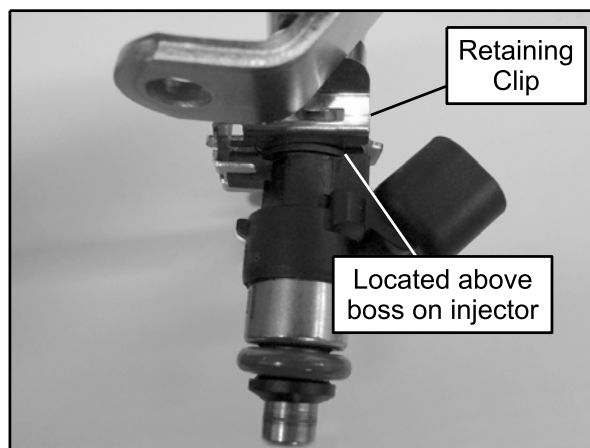

**NOTE:** Be sure the retaining clip is positioned on the injector and fuel rail as shown above.

13. Thoroughly clean the area around the fuel injector ports on the throttle body.
14. Lightly lubricate the injector O-rings and reinstall the fuel rail / injector assembly into the throttle body.

4.21

## ELECTRONIC FUEL INJECTION

15. Install the fuel rail mounting screws and torque to specification.



Fuel Rail Mounting Screws:  
**44 in-lb (5 Nm)**

16. Reinstall the fuel line to the fuel rail.  
17. Connect the harness leads to the fuel injectors.

**NOTE:** Be sure to connect the PTO harness lead to the PTO injector and the MAG harness lead to the MAG injector to ensure proper engine operation.

18. Use a tie strap to retain the harness leads to the fuel rail.  
19. Reconnect the negative battery cable and reinstall the driver's seat.  
20. Turn key on to allow the fuel system to prime and inspect the fuel rail and injectors for fuel leaks.

21. Reinstall the intake plenum assembly and fasten the lower mount to the transmission mount bracket.

- Be sure the lower air box post is placed properly into the rubber grommet.

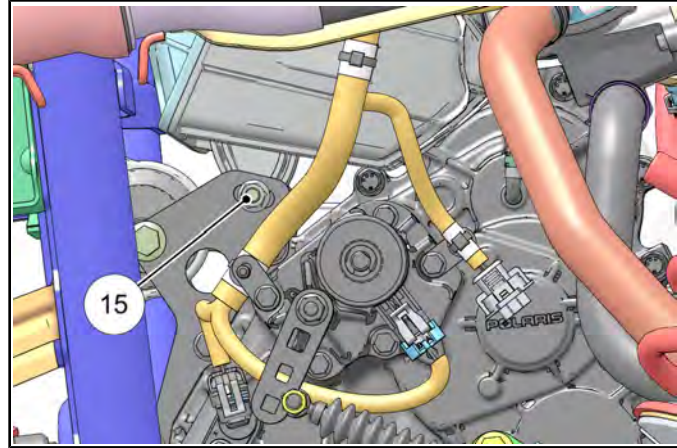

- Be sure the air box boots fully seat onto the dual throttle body before tightening the hose clamps (Item 16).

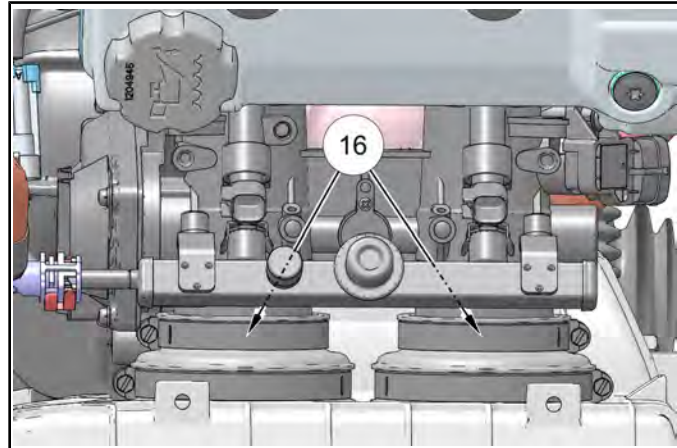

Hose Clamps:  
**35 in-lb (4 Nm)**

Intake Plenum Mount Screw:  
**22 ft-lb (30 Nm)**

22. Reinstall the breather into the air box and tighten the hose clamps retaining the air box to the throttle body assembly.  
23. Reinstall the two screws retaining the air box assembly.

# ELECTRONIC FUEL INJECTION

24. Position the intake hose onto the air box and tighten the hose clamp.
25. Reinstall the cargo box access panel.

## FUEL PUMP

### Operation Overview

An electric fuel pump assembly is used to transfer fuel to the EFI system from inside the fuel tank. This assembly includes the fuel pump, fuel filters, regulator and fuel gauge sender. The pump is rated for a minimum output of 25 liters per hour at  $58 \pm 2$  psi ( $400 \pm 14$  kPa) and has two non-serviceable fuel filters.

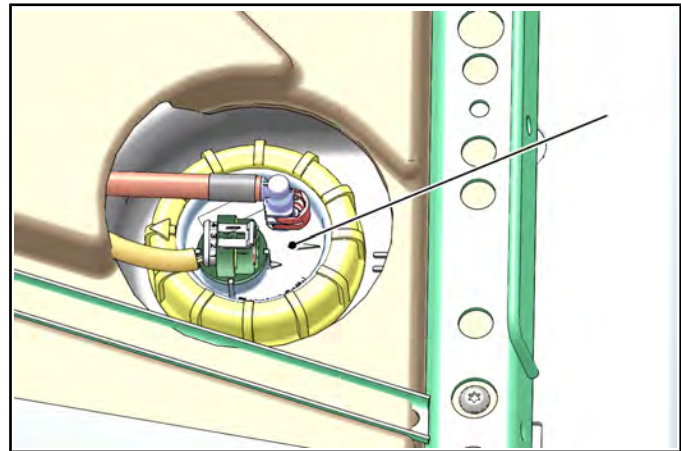

4

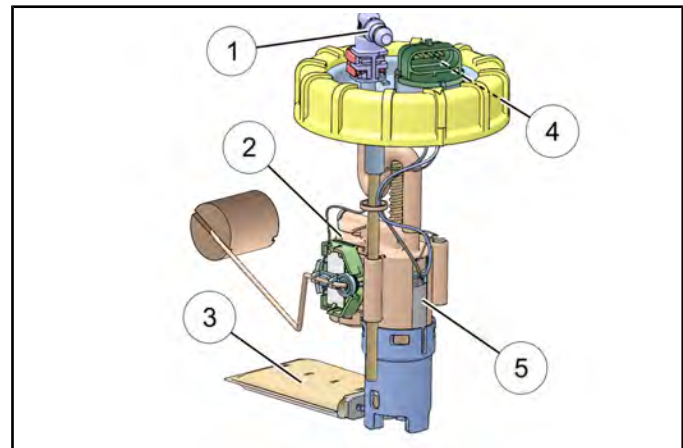

1. Fuel Line Connection	4. Pump / Sending Unit Electrical Connection
2. Fuel Pump	5. Regulator
3. Preliminary Filter	

When the key switch is turned to "ON", the ECU activates the fuel pump, which pressurizes the system for start-up.

The ECU switches off the pump preventing the continued delivery of fuel in these instances:

- If the key switch is not promptly turned to the "start" position.
- If the engine fails to start.

4.23

# ELECTRONIC FUEL INJECTION

- If the engine is stopped with the key switch "on" (as in the case of an accident).

In these situations, the "check engine" light will go on, but will turn off after 4 cranking revolutions if system function is OK. Once the engine is running, the fuel pump remains on.

## Fuel Sender Test

If the fuel gauge reading on the instrument cluster is not working, or if the display reading differs in large comparison to the fuel in the tank, perform a resistance test on the fuel sender.

Disconnect the fuel pump / sending unit connection and measure the resistance. If out of specification, replace the fuel pump assembly.

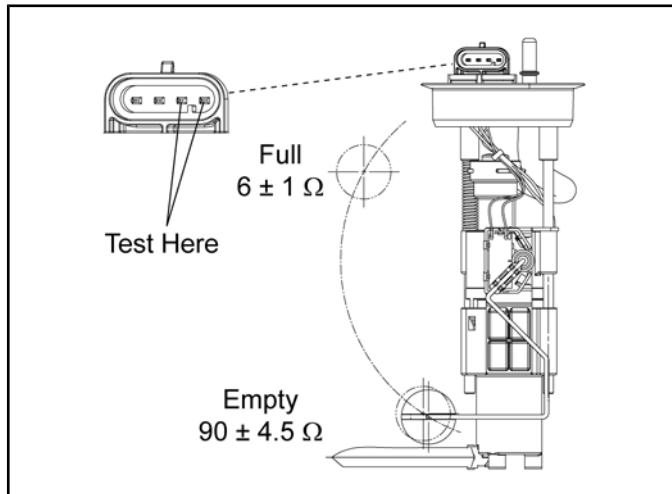

**Fuel Sender Resistance Specifications:**  
Full:  $6 \pm 1 \Omega$   
Empty:  $90 \pm 4.5 \Omega$

## Fuel Pump Test

If a fuel delivery problem is suspected, make certain the fuel pump filters are not plugged, that the pump is being activated through the ECU, all electrical connections are properly secured, the fuses are good, and a minimum of 7.0 volts is being supplied. If during starting the battery voltage drops below 7.0 volts, the ECU will fail to operate the system.

### **WARNING**

Fuel is extremely flammable and may cause severe burns, injury, or death.  
Do not use any device that produces a flame or electrical devices that may spark around fuel or fuel vapors.

1. Remove the passenger seat from the vehicle.
2. Cover the fuel line connection at the fuel tank with a shop towel and disconnect the line from the fuel pump outlet.
3. Install the Fuel Pressure Gauge Adapter (PV-48656) in-line between the fuel pump outlet and fuel line.
4. Connect the hose from the Fuel Pressure Gauge Kit (PU-43506-A) to the test valve on the Fuel Pressure Gauge Adapter (PV-48656). Route clear hose into a portable gasoline container or the vehicle's fuel tank.
5. Turn on key switch to activate the pump and check the system pressure on the gauge. If system pressure of  $58 \pm 2$  psi ( $400 \pm 14$  kPa) is observed, the ignition switch, ECU, fuel pump, and pressure regulator are working properly. Turn the key switch off and depress the valve button on the tester to relieve the system pressure.

**Normal Fuel Pressure:  $58 \pm 2$  psi ( $400 \pm 14$  kPa).**

**NOTE: If the fuel pressure is out of specification, replace the fuel pump assembly.**

# ELECTRONIC FUEL INJECTION

6. If the pump did not activate (Step 5), disconnect the harness connector from the fuel pump. Connect a DC voltmeter across terminals "3" and "4" in the plug on the vehicle fuel pump harness. Turn on the key switch and observe voltage to ensure a minimum of 7 volts is present.

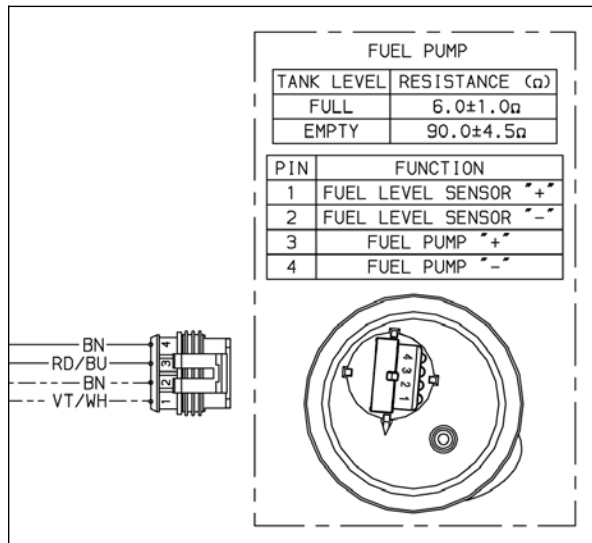

**NOTE:** If the voltage was below 7 VDC, test the battery, ignition switch, relay(s), wiring harness and ECU.

7. If the reading is between 7 and 14 volts, turn key switch off and connect an ohmmeter between terminals "3" and "4" at the white fuel pump connector to check for continuity within the fuel pump.

**NOTE:** If there was no continuity between the pump terminals, replace the fuel pump assembly.

8. If voltage at the plug was within the specified range, and there was continuity across the pump terminals, reconnect the plug to the fuel pump, making sure you have a clean connection. Turn on the key switch and listen for the pump to activate.

**NOTE:** If the pump starts, repeat steps 3, 4 and 5 to verify correct pressure.

9. If the pump still does not operate, check for correct ECU operation by plugging in a known-good ECU of the same model.

**NOTE:** If the pump still does not operate, replace the fuel pump assembly.

## Fuel Pump Replacement

1. Move the vehicle to a well ventilated area. Shift the transmission into Park and turn the ignition key off.
2. Remove the passenger seat to access the fuel pump.

### WARNING

Always wear safety goggles when working with high pressure or flammable fluids. Failure to do so could result in serious injury or complications.

3. Be sure the top of the fuel tank is clean (Item 1). If it requires cleaning, hand wash the top of the tank to ensure no debris will enter the fuel system when the fuel pump is removed.

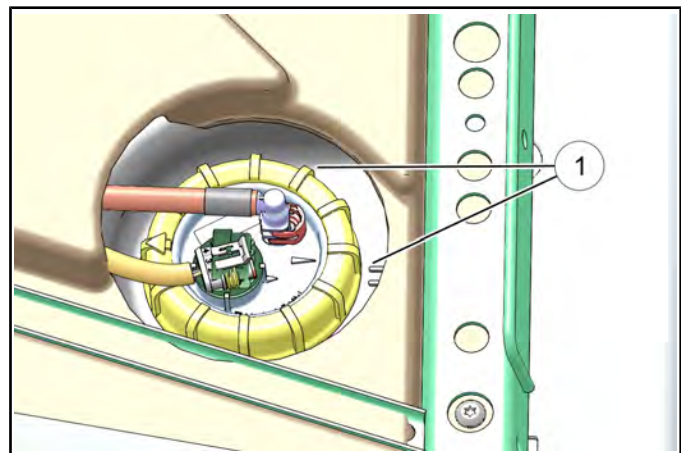

### WARNING

Failure to clean area around fuel pump may lead to debris entering the fuel tank during service. Excessive debris in fuel tank may cause premature wear of fuel pump and/or clogging of internal fuel filters.

4. Ensure that static has been discharged by touching a ground source such as the engine or frame.

4

## ELECTRONIC FUEL INJECTION

5. While holding a shop towel over the fuel line connectors, disconnect the fuel supply line (Item 2) from the pump and the fuel return line (B) from the tank (see "Fuel Lines - Quick Connect Fittings" for specific removal procedures).

### CAUTION

It is possible for pressurized fuel to be present when disconnecting the fuel line. It is recommended to allow the vehicle to sit for a period of one hour after shutting off the engine before servicing the fuel pump. This allows the exhaust to cool and fuel pressure to drop.

**NOTE: A small amount of fuel may come out of the fuel lines or pump fitting. Properly drain fuel into a suitable container.**

6. Disconnect the fuel pump electrical harness (Item 3).

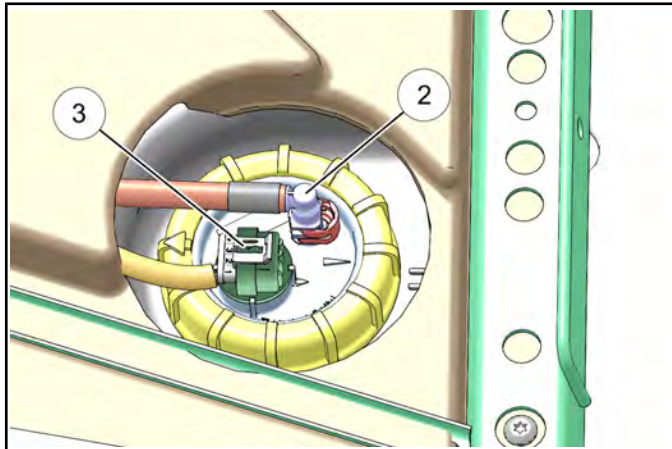

7. Place the Fuel Pump Service Tool (PU-50326) over the fuel pump PFA nut (Item 4). Using a 1/2" drive ratchet or breaker bar, loosen and remove the PFA nut. Discard the PFA nut.

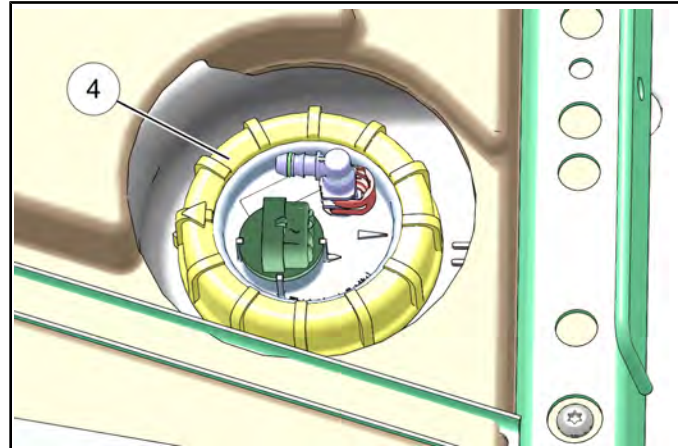

**NOTE: Apply downward force on the fuel pump flange while removing the fuel pump PFA nut.**

## ELECTRONIC FUEL INJECTION

8. Carefully lift the fuel pump out of the fuel tank. As the fuel pump assembly is being removed, be aware of float arm and pump pre-filter. Hold the float arm to the pump body as you lift and tilt the pump to ensure that the float arm is not bent when removed from the tank.

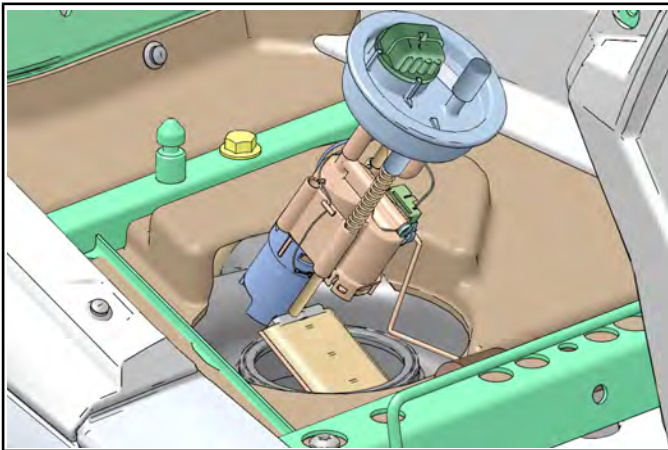
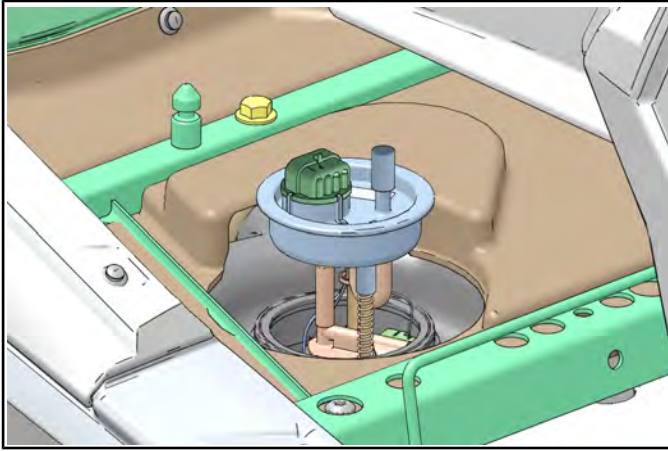

9. Transfer old fuel pump to a suitable container capable of safely holding fuel. The fuel pump will retain some fuel.
10. Inspect the inside of the fuel tank for debris (may require flashlight and mirror). If debris like mud or sand is present, fuel tank should be flushed and cleaned out prior to installation of new fuel pump assembly.

**NOTE:** It is recommended to remove the fuel tank from the vehicle and rinse it with a small amount of clean fuel. Do not use water or any other chemicals to remove debris.

11. Remove new fuel pump assembly (Item 5), gasket (Item 6) and PFA nut (Item 7) from packaging. Use care not to bend float arm (Item 8) during unpackaging. Do not lift or carry fuel pump assembly by the float arm.

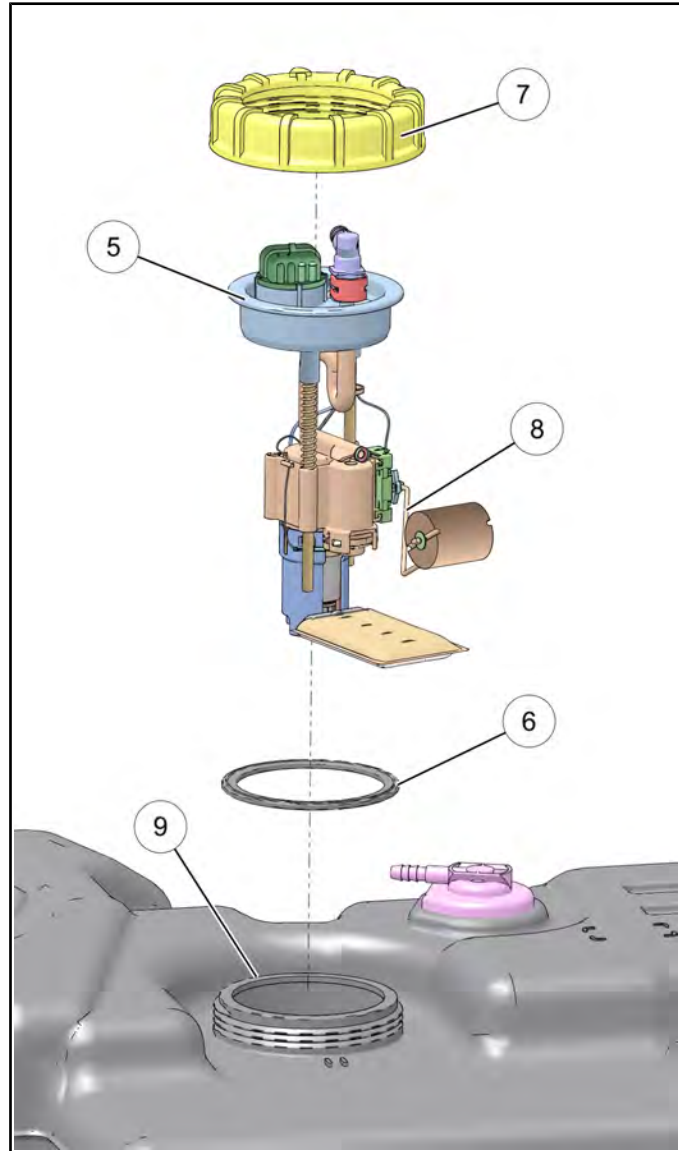

12. Use cleaning wipes provided to clean fuel tank surface and threads (Item 9). Remove all debris, grease and oil. Allow surfaces to dry completely.
13. Install new PFA gasket onto fuel pump assembly using care not to damage gasket or bend float arm.
14. Install fuel pump into fuel tank, hold float arm to the pump body and tilt assembly to ensure float arm does not get caught or bent during installation.
15. Gently push down on fuel pump flange ensuring gasket is centered.



## ELECTRONIC FUEL INJECTION

16. Roughly align orientation mark on fuel pump between the orientation marks on fuel tank to ensure float arm does not get bent or snagged.

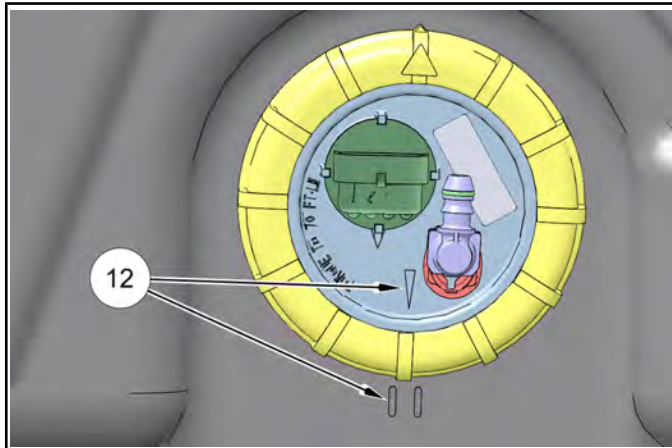

### WARNING

Failure to align the orientation marks may lead to interferences with the fuel level float arm and cause incorrect function.

17. While maintaining downward pressure, thread new PFA nut onto fuel tank and hand tighten. Use care when starting PFA nut, ensuring threads are properly aligned. Verify orientation marks are still aligned between fuel pump and fuel tank.
18. Torque PFA nut to specification using the Fuel Pump Service Tool (PU-50326) and a calibrated torque wrench.



Fuel Pump PFA Nut:  
**70 ft-lbs (95 Nm)**

19. Verify alignment of fuel pump and tank orientation marks.
20. Connect the fuel supply line to the pump (see "Fuel Lines - Quick Connect Fittings" for specific installation procedures).

**NOTE: Be sure to engage the retainers on each fuel line until each snaps into place. Pull on fuel lines lightly to confirm connection.**

21. Install the fuel tank vent line onto the tank fitting.
22. Connect the fuel pump electrical harness.

23. Test the fuel pump by turning on the key and listening for the pump to activate. Cycle the key several times to prime the system.

24. Install the passenger seat / storage box.

## ELECTRONIC FUEL INJECTION

### TEMPERATURE / MANIFOLD ABSOLUTE PRESSURE (T-MAP) SENSOR

#### Operation Overview

Mounted on the end of the intake, the T-MAP (Item 1) performs two functions in one unit. The T-MAP detects intake air temperature as well as manifold absolute pressure.

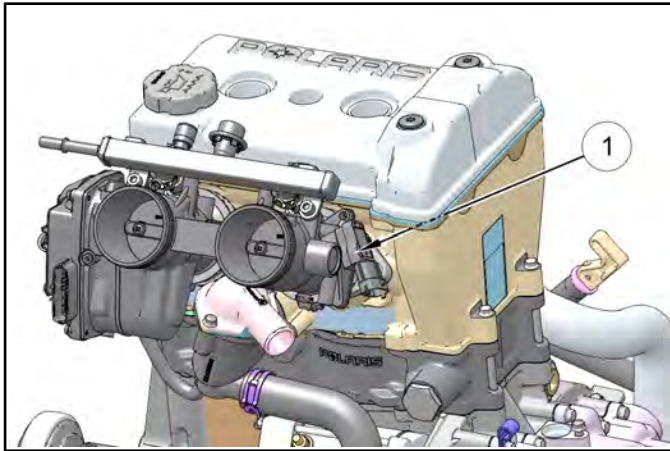

These sensor signals, comprised of separate intake air temperature and manifold absolute pressure readings are processed by the ECU and compared to its programming for determining the fuel and ignition requirements during engine operation. The T-MAP provides the ECU with engine load data.

#### T-MAP Test / Replacement

The T-MAP is a non-serviceable item and can only be tested using Digital Wrench®. If the sensor is faulty, it must be replaced.

**NOTE: This sensor should only be tested using Digital Wrench® Diagnostic Software (dealer only).**

### CRANKSHAFT POSITION SENSOR (CPS)

#### Operation Overview

Mounted on top of the stator cover, the crankshaft position sensor (Item 1) is essential to engine operation, constantly monitoring the rotational speed (RPM) and position of the crankshaft.

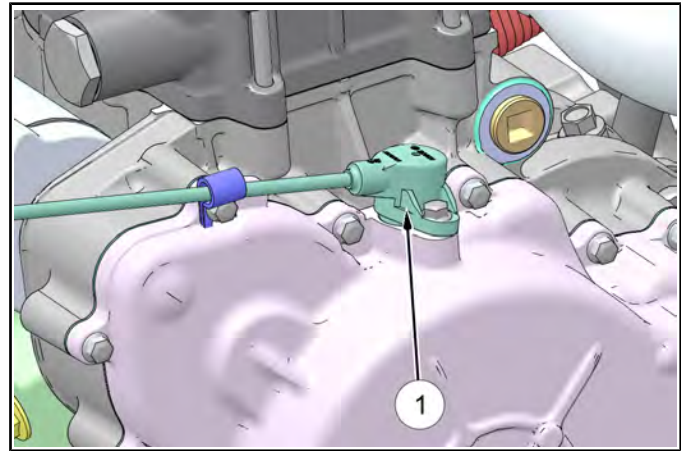

A ferromagnetic 35-tooth encoder ring with a missing tooth is built onto the flywheel. The inductive speed sensor is mounted  $1.0 \pm 0.26$  mm ( $0.059 \pm 0.010$  in.) away from the encoder ring. During rotation, an AC pulse is created within the sensor for each passing tooth. The ECU calculates engine speed from the time interval between the consecutive pulses.

The encoder ring missing tooth creates an “interrupt” input signal, corresponding to specific crankshaft position. This signal serves as a reference for the control of ignition timing by the ECU. Synchronization of the CPS and crankshaft position takes place during the first two revolutions each time the engine is started. This sensor must be properly connected at all times. If the sensor fails or becomes disconnected for any reason, the engine will stop running.

4

# ELECTRONIC FUEL INJECTION

## CPS Test

The CPS is a sealed, non-serviceable assembly. If fault code diagnosis indicates a problem with this sensor, test as follows:

1. Locate the CPS harness connector above the transmission on the RH side of the vehicle and disconnect the harness.
2. Connect an ohmmeter between the CPS pin terminals shown below. A resistance value of **1000Ω ± 10%** at room temperature should be obtained.

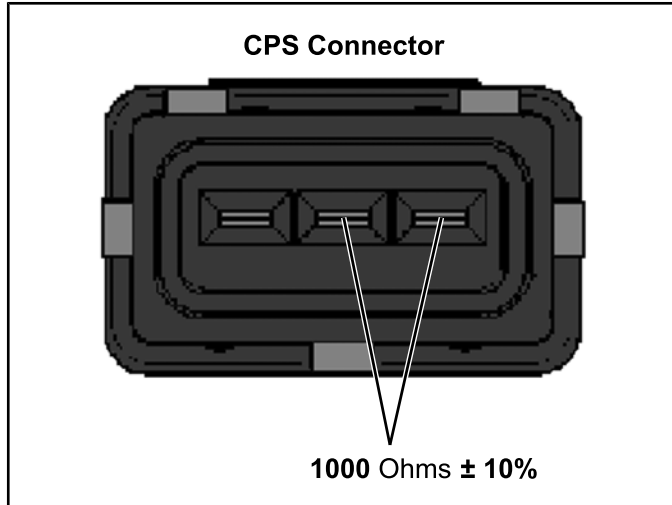

**CPS Resistance Specification:  
1000Ω ± 10%**

3. If the resistance is correct:
  - Test the main harness circuit between the sensor connector terminals and the corresponding pin terminals at the ECU (see wiring diagram).
  - Check the sensor mounting, air gap, flywheel encoder ring for damage or runout, and flywheel key. Follow the CPS Replacement procedure to inspect CPS and flywheel encoder ring for damage.
4. If the resistance is incorrect, follow the "CPS Replacement" procedure.

## CPS Replacement

1. If not done already; disconnect the CPS harness connector (see "CPS Test").
2. Using an 8mm socket, remove the CPS retaining bolt (Item 1) and remove the sensor (Item 2) from the stator cover.

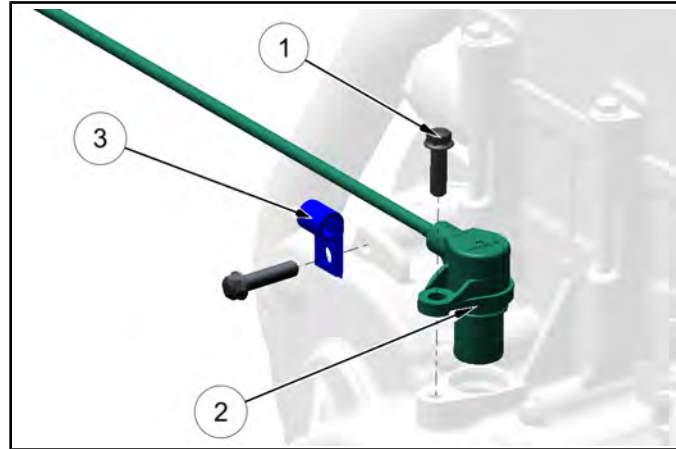

3. Unclip the wire harness retainer (Item 3) and remove the CPS harness from the retainer to allow replacement.
4. Install new sensor using a light coating of oil on the O-ring to aid installation.
5. Torque the CPS retaining bolt to specification.

 = T

**CPS Retaining Bolt:  
9 ft-lb (12 Nm)**

# ELECTRONIC FUEL INJECTION

## THROTTLE BODY ASSEMBLY

### Operation Overview

Mounted to the cylinder head, the dual throttle body (Item 1) assembly provides the proper air/fuel ratio needed for engine operation.

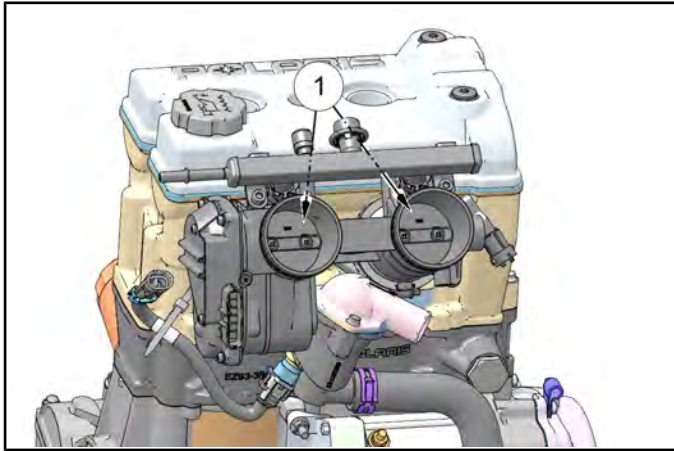

The throttle body assembly also includes the Electronic Throttle Control and Idle Air Control.

### Throttle Body Service

The throttle body assembly is a non-serviceable component. However, the fuel rail and fuel injectors can be serviced separately (see "Fuel Injectors"). The Manifold Air Quality Sensor (MAQS) attached to the end of the throttle body is non-serviceable. If the sensor is faulty, the entire throttle body assembly must be replaced. Refer to "Throttle Body Removal" procedure.

### Throttle Body Removal

1. Remove the cargo box assembly (See Cargo Box Assembly Removal, page 5.21).
2. Be sure the engine has cooled enough to work on.

3. Loosen the hose clamps (Item 1) retaining the intake plenum (Item 2) to the throttle body.

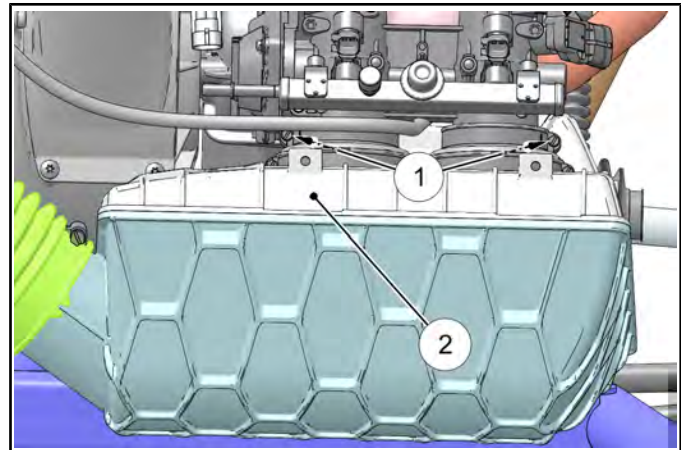

4. Remove the two screws (Item 3) retaining the intake plenum.

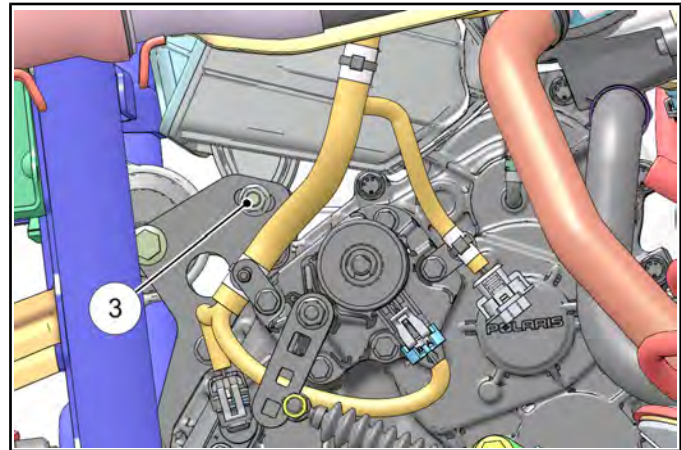

5. Remove the driver's seat and disconnect the negative battery cable.
6. Disconnect the wire harness from the ETC (Item 4) and the TMAP (Item 5) located on the ends of the throttle body assembly.

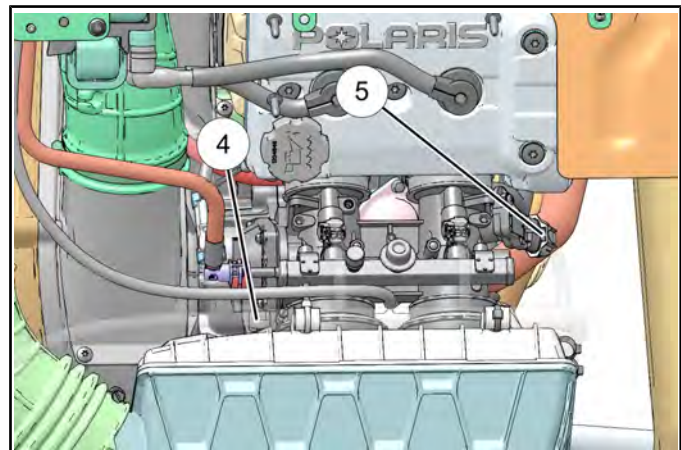

# ELECTRONIC FUEL INJECTION

7. Loosen the two hose clamps (Item 6) that retain the dual throttle body assembly (Item 7) to the intake adapters. Carefully lift the throttle body assembly out of the intake adapters.

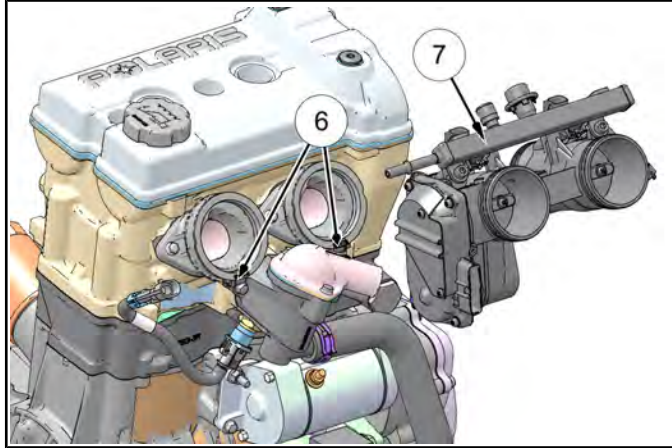

8. Remove the two screws retaining the fuel rail to the throttle body. Lift the fuel rail and injectors out of the throttle body assembly taking care not to damage the fuel injector ends.

**NOTE: It is not necessary to disconnect fuel lines or the injector harnesses to perform this procedure.**

9. Reverse the previous steps to reinstall the throttle body.
10. Upon installation of the fuel rail and injectors, lightly lubricate injector O-rings to aid installation. Torque the fuel rail mounting screws to specification.



Fuel Rail Mounting Screws:  
**44 in-lb (5 Nm)**

## ELECTRONIC THROTTLE CONTROL (ETC)

### Operation Overview

**NOTE: DO NOT attempt to service the ETC (Item 1). The ETC is a non-serviceable component and can only be tested using Digital Wrench®. If the ETC is faulty, the entire assembly must be replaced.**

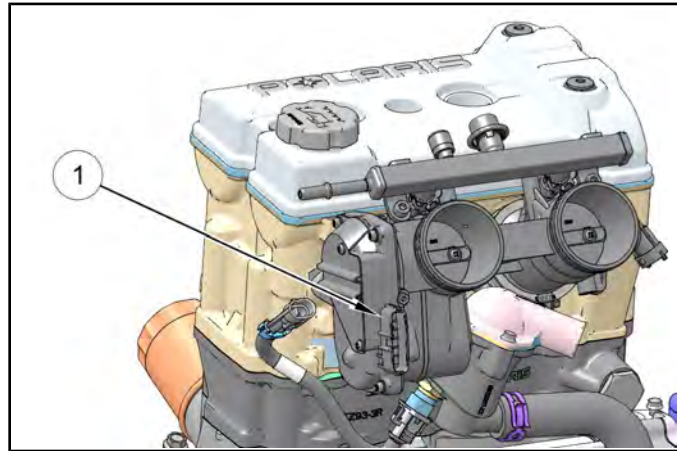

Mounted to the intake plenum, the ETC acts as an electronically controlled throttle body. The ETC controls engine throttle operation to provide the proper air/fuel ratio needed for engine operation at all RPM ranges. The ETC controls engine RPM based off input provided by the Pedal Position Sensor (PPS) and Electronic Control Unit (ECU).

### ETC Test

Never attempt to disassemble the ETC assembly. Warranty is void if the end cover is opened or tampered with in any way.

All operating and control functions within the ETC are pre-set. No internal servicing or adjustments may be performed. If a problem is encountered, and you determine the ETC to be faulty, contact the Polaris Service Department for specific handling instructions. Do not replace the ETC without factory authorization.

Use Digital Wrench® to perform all troubleshooting of this component. Use a Volt Ohm meter to test the vehicle harness continuity between the ETC connector and ECU connector. Refer to the wire diagram for pin-out details. If the ETC is faulty, the entire ETC assembly must be replaced (see "ETC Replacement").

# ELECTRONIC FUEL INJECTION

## ETC Replacement

1. Remove the cargo box access panel.
2. Remove wire harness from the ETC (Item 1).

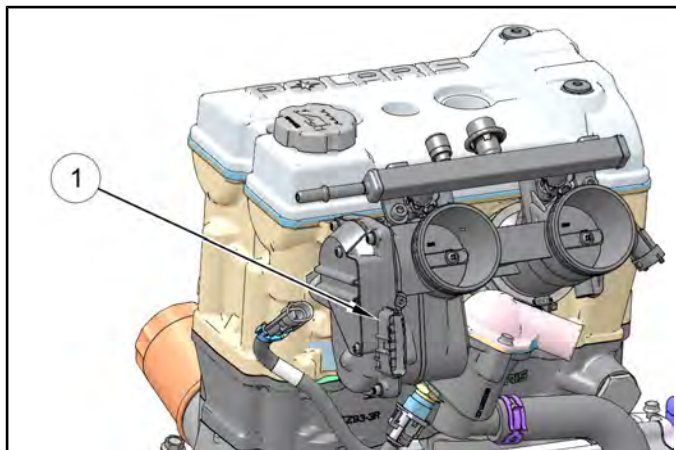

3. Remove the four bolts retaining the ETC housing to intake plenum.
4. Remove the ETC housing and gasket from intake plenum.
5. Reverse these steps for installation. Torque the ETC housing retaining bolts and intake boot clamp to specification.



ETC Housing Retaining Bolts:  
7 ft-lb (10 Nm)

Intake Boot Clamp:  
35 in-lb (4 Nm)

## PEDAL POSITION SENSOR (PPS)

### Operation Overview

**NOTE: DO NOT attempt to service the PPS. The PPS is a non-serviceable component and can only be tested using Digital Wrench®. If the PPS is faulty, the entire throttle pedal assembly must be replaced.**

Mounted to the throttle pedal assembly, the PPS acts as a throttle position sensor. The PPS provides throttle pedal position to the Electronic Control Unit (ECU) to increase or decrease engine RPM using the Electronic Throttle Control (ETC). The PPS is the primary input used to control engine speed during vehicle operation.

### Location

The ETC switch (Item 1) is located in the drivers foot control area, mounted on the top of the throttle pedal assembly.

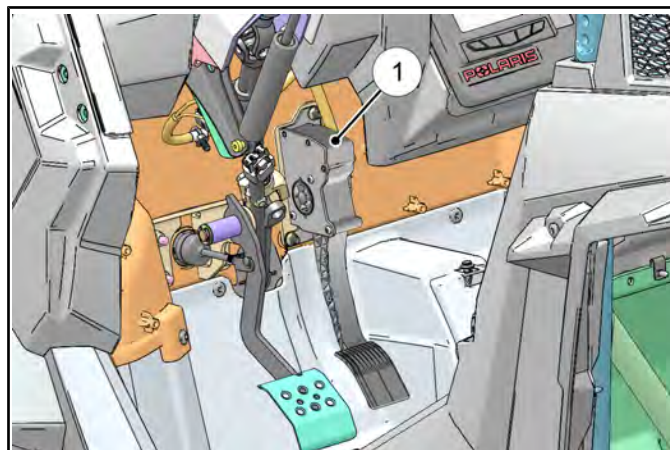

### PPS Test

The PPS can be tested utilizing Digital Wrench® by verifying that throttle position readout varies as the pedal is pressed. Reference the Data Display section and be sure Throttle Position is displayed. With the ignition key on for at least 15 seconds and engine not running, the Throttle Position will read approximately 9.6% when the pedal is released. With the pedal fully depressed, the Throttle Position will vary depending on what gear you have selected.

- High/Neutral/Park/Invalid ≈ 70%.
- Low ≈ 60%
- Reverse ≈ 32%

# ELECTRONIC FUEL INJECTION

1. With the throttle pedal “at rest”, connect an ohmmeter between the TRS pin terminals. A resistance value of **2.15k Ohms +/- 5%** at room temperature should be obtained. If the sensor reading is more than **2.26k Ohms**, it is out of specification and needs to be replaced.
2. With the throttle pedal **fully depressed**, connect an ohmmeter between the TRS pin terminals. A resistance value of **6.8k Ohms +/- 5%** at room temperature should be obtained. If the sensor reading is less than **6.46k Ohms**, it is out of specification and needs to be replaced.

THROTTLE “AT REST”	THROTTLE FULLY DEPRESSED
<b>2.15 k Ohms +/-5%</b>	<b>6.8 k Ohms +/-5%</b>
Replace sensor if reading is more than: <b>2.26 k Ohms</b>	Replace sensor if reading is less than: <b>6.46 k Ohms</b>

The Pedal Position Sensor is calibrated to the throttle pedal. If the PPS is faulty, the throttle pedal assembly must be replaced (see "PPS Replacement").

## PPS Replacement

**NOTE: The PPS is calibrated to the throttle pedal. If the PPS is faulty, the throttle pedal assembly must be replaced.**

1. Disconnect the PPS harness connection (Item 2) located on the throttle pedal.

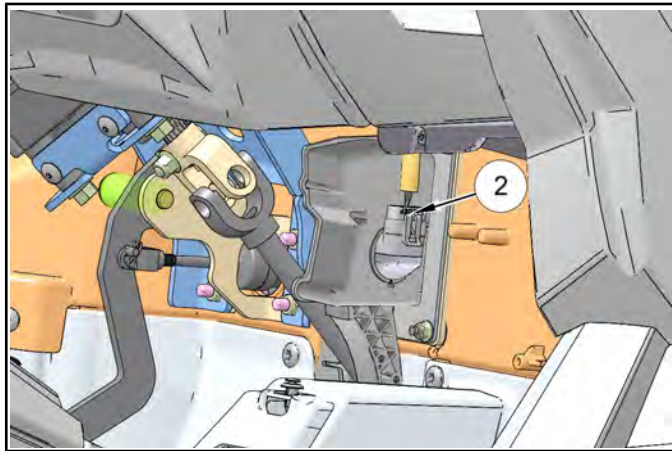

2. Remove the drivers seat and disconnect the negative (-) battery cable.

3. Remove the three bolts (Item 3) securing the throttle pedal assembly to the frame support.

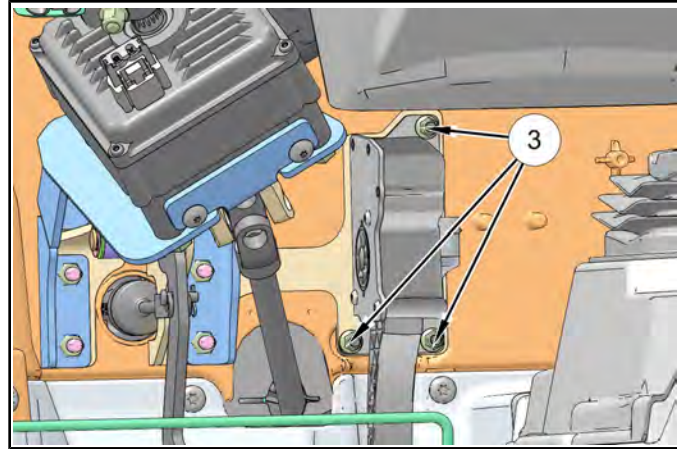

4. Remove the pedal assembly from the vehicle.

## ETC Installation

5. Place the throttle pedal assembly on the mounting studs and loosely install the three fasteners.
6. Torque the three mounting bolts to specification and connect the PPS harness connection.



Throttle Pedal Mounting fasteners:  
**18 ft-lb (24 Nm)**

7. Manually cycle the throttle pedal to verify the throttle pedal moves freely.
8. Connect the negative (-) battery cable and install the drivers seat.

# ELECTRONIC FUEL INJECTION

## EFI DIAGNOSTICS

### Instrument Cluster Trouble Code Display

**NOTE:** The diagnostic mode is accessible only when the check engine MIL has been activated.

Use the following procedure to display diagnostic trouble codes that were activated during current ignition cycle causing the MIL to illuminate. Diagnostic trouble codes will remain stored in the gauge (even if MIL turns off) until the key is turned off.

**NOTE:** If there is a diagnostic problem with the power steering system, the power steering MIL will illuminate and blink in place of the check engine MIL.

1. If the trouble code (s) are not displayed, use the MODE button to toggle until "CK ENG" displays on the information display area.



2. Press and hold the MODE button to enter the diagnostics code menu.

3. A set of three numbers will appear in the information area.

- The first number (located far left) can range from 0 to 9. This number represents the total number of trouble code present (example: 2 means there are 3 codes present).
- The second number (located top right) can be 2 to 6 digits in length. This number equates to the suspected area of fault (SPN).
- The third number (located bottom right) can be 1 to 2 digits in length. This number equates to the fault mode (FMI).

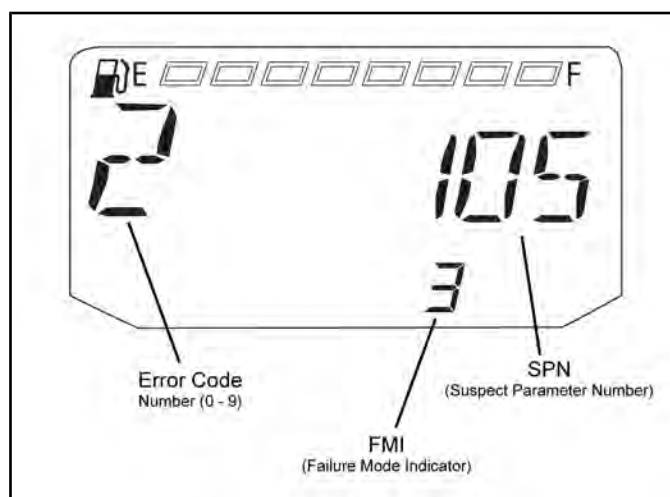

4

4. If more than one code exists, press the MODE button to advance to the next trouble code.
5. To exit the diagnostic mode, press and hold the MODE button or turn the ignition key OFF once the codes are recorded.

### DIAGNOSTIC TROUBLE CODE TABLE

COMPONENT	CONDITION	SPN	FMI	DIGITAL WRENCH® P-CODE
Accelerator Position 2	Voltage Too High	29	3	P1228
	Voltage Too Low		4	P1227
	Not Plausible		2	P1225
Throttle Position Sensor 1	Voltage Too High	51	3	P0123
	Voltage Too Low		4	P0122
	Signal Out of Range		2	P0121
Vehicle Speed Signal	Data Erratic or Intermittent (or missing)	84	2	P0503
	Received Vehicle Speed Has Error		19	C1069
Accelerator Position 1	Voltage Too High	91	3	P0228
	Voltage Too Low		4	P0227
	Not Plausible		2	P0225



## ELECTRONIC FUEL INJECTION

COMPONENT	CONDITION	SPN	FMI	DIGITAL WRENCH® P-CODE
Manifold Absolute Pressure Sensor (T-MAP)	Voltage Too High	102	3	P0108
	Voltage Too Low		4	P0107
Intake Air Temperature (T-MAP)	Voltage Too High	105	3	P0113
	Voltage Too Low		4	P0112
Engine Temperature Sensor (ECT)	Voltage Too High	110	3	P0118
	Voltage Too Low		4	P0117
	Temperature Too High		16	P0217
	Engine Overheat Shutdown		0	P1217
System Power (Battery Potential / Power Input)	Voltage Too High	168	3	P0563 C1063
	Voltage Too Low		4	P0562 C1064
Engine Speed (This is applicable when the EPS module gets the engine speed from the ECM)	Error in Engine Speed Computation	190	31	P121C
	Received Engine Speed Has Error		19	C1066
Engine Speed	Error in Engine Speed Computation	400	31	P121D
Gear Sensor Signal	Voltage Too Low	523	4	P0916
ECU Memory	EEPROM: Read/Write Failure	628	12	C1073
Calibration	Checksum/CRC Error	630	13	C1074
Crankshaft Position Sensor (CPS)	Plausibility Fault	636	2	P0335
Injector 1 (MAG)	Driver Circuit Open / Grounded	651	5	P0261
	Driver Circuit Short to B+		3	P0262
	Driver Circuit Grounded		4	P1262
Injector 2 (PTO)	Driver Circuit Open / Grounded	652	5	P0264
	Driver Circuit Short to B+		3	P0265
	Driver Circuit Grounded		4	P1265
Rear Differential Output	Driver Circuit Open / Grounded	746	5	P1691
	Driver Circuit Short to B+		3	P1692
	Driver Circuit Grounded		4	P1693
Fan Relay Driver Circuit	Driver Circuit Open / Grounded	1071	5	P1481
	Driver Circuit Short to B+		3	P1482
	Driver Circuit Grounded		4	P1483
Ignition Coil Primary Driver 1 (MAG)	Driver Circuit Short to B+	1268	3	P1353
Ignition Coil Primary Driver 2 (PTO)	Driver Circuit Short to B+	1269	3	P1354
Fuel Pump Driver Circuit	Driver Circuit Open / Grounded	1347	5	P0230
	Driver Circuit Short to B+		3	P0232
	Driver Circuit Grounded		4	P0231
ECU Output Supply Voltage 1	Voltage Too High	3597	3	P16A2
	Voltage Too Low		4	P16A1

## ELECTRONIC FUEL INJECTION

COMPONENT	CONDITION	SPN	FMI	DIGITAL WRENCH® P-CODE
ECU Output Supply Voltage 2	Voltage Too High	3598	3	P16A9
	Voltage Too Low		4	P16A8
ECU Output Supply Voltage 3	Voltage Too High	3599	3	P17AA
	Voltage Too Low		4	P17AB
ETC Accelerator Position Sensor Outputs 1 & 2 Correlation	Correlation Fault	65613	2	P1135
Throttle Position Sensor 2	Voltage Too High	520198	3	P0223
	Voltage Too Low		4	P0222
	Signal Out of Range		2	P0221
All Wheel Drive Control Circuit (AWD)	Driver Circuit Open / Grounded	520207	5	P1836
	Driver Circuit Short to B+		3	P1835
	Driver Circuit Grounded		4	P1834
Steering Over Current Shut Down	Current Above Normal or Grounded	520221	6	C1050
Steering Excessive Current Error	Current Above Normal or Grounded	520222	6	C1051
Steering Torque Partial Failure	Condition Exists	520223	31	C1052
Steering Torque Full Failure	Condition Exists	520224	31	C1053
EPS Inverter Temperature	Greater than 110° C (230° F)	520225	16	C1054
	Greater than 120° C (248° F)		0	C1055
EPS CAN Communications Receive Error	No RX Message for 2 Seconds	520226	2	U0100
EPS CAN Communications Transmit Error	No TX Message for 2 Seconds	520227	2	U1100
Position Encoder Error	Position Encoder Error	520228	11	C1065
EPS Software Error	Software Error	520229	12	C1070
IC CAN Communication with EPS	EPS Off Line (EPS DM1 not seen)	520230	31	U0131
EPS Power Save Condition	EPS: Key On, Engine Off, 5 Minute Power Save/Timeout	520231	31	C1071
Accelerator Position / Brake Position Interaction	Condition Exists	520275	31	P150A
Throttle Position Sensor (1 or 2 Indeterminable)	Neither Position Sensor Passed Test	520276	12	P150B
	Position Sensor Correlation Fault		2	P150C
Throttle Body Control - Power Stage	Maximum	520277	3	P150D
	Minimum		4	P150E
	Not Plausible		2	P151A
	Signal Error		8	P151B
	Deactivated power stages due to 5V sensor supply error		31	P153F
Throttle Body Control - Return Spring Check Failed	Condition Exists	520278	31	P151C
Throttle Body Control - Adaptation Aborted	Condition Exists	520279	31	P151D

4

## ELECTRONIC FUEL INJECTION

COMPONENT	CONDITION	SPN	FMI	DIGITAL WRENCH® P-CODE
Throttle Body Control - Limp Home Position Check Failed	Condition Exists	520280	31	P151E
Throttle Body Control - Mechanical Stop Adaptation Failure	Condition Exists	520281	31	P152A
Throttle Body Control - Repeated Adaptation Failed	Condition Exists	520282	31	P152B
Throttle Body Control	Maximum	520283	3	P152C
	Minimum		4	P152D
	Outside of Pedal Range (Level 1)		2	P152F
Throttle Body Control - Position Deviation Fault	Condition Exists	520284	31	P152E
Brake Switch (1 or 2 Indeterminable)	Brake Switch Correlation Fault	520285	2	P153E
ECU Monitoring Error	Condition Exists	520286	31	P1540
ECU Monitoring Error (Level 3)	Condition Exists	520287	31	P1541
ECU Monitoring of Injection Cut Off (Level 1)	Condition Exists	520288	31	P1542
ECU Monitoring of Injection Cut Off (Level 2)	Condition Exists	520289	31	P1543
Controller Option Setting Not Programmed	Out of Calibration	520290	13	P1544
Throttle Body Control - Requested Throttle Angle Not Plausible	Condition Exists	520305	31	P1530
ECU Analog to Digital Converter Fault - No Load	Condition Exists	520306	31	P1531
ECU Analog to Digital Converter Fault - Voltage	Condition Exists	520307	31	P1532
Accelerator Sensor Synchronicity Fault Sensor Difference Exceeds Limit	Condition Exists	520308	31	P1533
ECU Fault - ICO	Condition Exists	520309	31	P1534
ECU Fault - Hardware Disruption	Condition Exists	520311	31	P1537

## EFI Troubleshooting

### Fuel Starvation / Lean Mixture

**Symptoms:** Hard start or no start, bog, backfire, popping through intake / exhaust, hesitation, detonation, low power, spark plug erosion, engine runs hot, surging, high idle, idle speed erratic.

- No fuel in tank
- Restricted tank vent, or routed improperly
- Fuel lines or fuel injectors restricted
- Fuel filter plugged
- Fuel pump inoperative
- Air leak in system
- Intake air leak (throttle shaft, intake ducts, air box cover)

### Rich Mixture

**Symptoms:** Fouls spark plugs, black, sooty exhaust smoke, rough idle, poor fuel economy, engine runs rough/ misses, poor performance, bog, engine loads up, backfire.

- Air intake restricted (inspect intake duct)
- Air filter dirty/plugged
- Poor fuel quality (old fuel)
- Fouled spark plug
- Injector failure

### Poor Idle

**Symptom:** Idle Too High (if > 1400 RPM when warm).

- Throttle stop screw tampering
- Throttle cable sticking, improperly adjusted, routed incorrectly
- Faulty electrical connection

**Symptom:** Idle Too Low (if < 1100 RPM when warm).

- Plugged air filter
- Leaking injector (rich condition)
- Belt dragging
- Throttle stop screw tampering

**Symptom:** Erratic Idle.

- Throttle cable incorrectly adjusted
- Air Leaks, dirty injector
- MAQS damaged (check with Digital Wrench®)
- Tight valves (low compression or high leakdown)

- Ignition timing incorrect
- Belt dragging
- Dirty air filter
- High percentage of cylinder leakdown (worn engine)
- Low compression (worn engine)
- Spark plug(s) fouled
- Spark plug wires loose or worn
- Faulty electrical connection

# ELECTRONIC FUEL INJECTION

---

## DIGITAL WRENCH® OPERATION

### Digital Wrench® Diagnostic Software Overview

**NOTE:** Refer to Section 2, 3 and 4 in the Instruction Manual provided in the Digital Wrench® Diagnostic Kit to install the Polaris Digital Wrench® diagnostic software on your computer.

The Digital Wrench® diagnostic software allows the technician to perform the following tests and observations:

- View or clear trouble codes
- Analyze real-time engine data
- Reflash ECU calibration files
- Perform guided diagnostic procedures
- Create customer service account records
- Perform output state control tests (some models)

### Special Tools (also refer to the beginning of this chapter)

DIGITAL WRENCH® DIAGNOSTIC SOFTWARE	PART NUMBER
Digital Wrench® Diagnostic Kit	PU-47063-B
PU-47063-B (listed above) INCLUDES:	Digital Wrench® Software: PU-48731
	Standard Interface Cable: PU-47151
	SmartLink Module Kit: PU-47471
	USB-Serial Adapter Cable: PU-50621
Fuel Pressure Gauge Kit	PU-43506-A
Fuel Pressure Gauge Adapter	PV-48656
Fluke 73 Digital Multi-Meter or Fluke 77 DMM	PV-43546 (Fluke 77: PV-43568)
Laptop or Desktop Computer	Commercially Available (refer to diagnostic software user manual or HELP section for minimum requirements)

# ELECTRONIC FUEL INJECTION

## Diagnostic Software Version

Always use the most current version of the Digital Wrench® software to ensure you have the latest updates or enhancements. New reprogramming files and guided diagnostic procedures are added to these updates as they become available. For information on how to determine if you have the latest update available, refer to “Digital Wrench® Version and Update ID”.

## Guided Diagnostic Available

Guided diagnostics are available within Digital Wrench® for all supported Trouble Codes (that is, any fault that will turn on the ‘Check Engine’ indicator).

In addition, guided diagnostics are also available for many other electrical sub systems.

Diagnostic procedures are added to subsequent versions of Digital Wrench® as they become available. Check your release version often and upgrade when available to be sure you are using the most current software available.

## Digital Wrench® Communication Errors

If you experience problems connecting to a vehicle or any Digital Wrench® related problem, visit the Digital Wrench® Knowledge Base for the most current troubleshooting information, FAQs, downloads and software updates at: <http://polaris.diaqs.com/>.

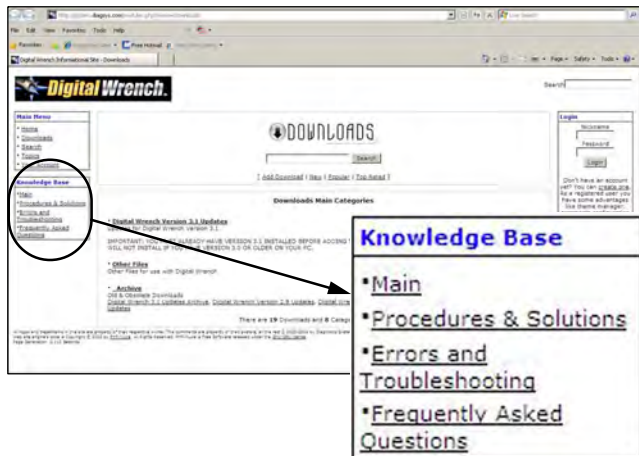

## Digital Wrench® - Diagnostic Connector

Located under the hood connected to a sealed plug (Item 1).

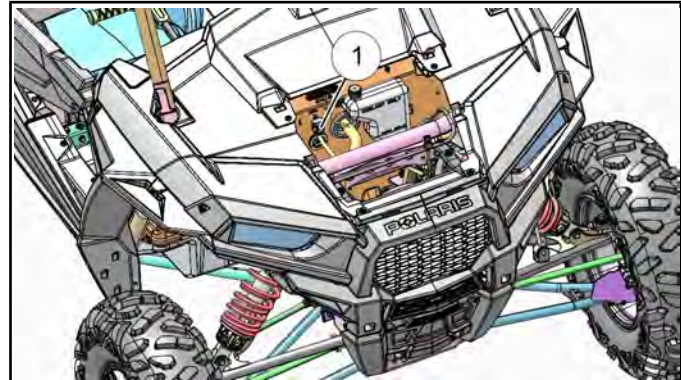

4

Follow these steps to connect the diagnostic interface cable to the vehicle to allow Digital Wrench® use:

1. Assemble the SmartLink Module and attach the PC Interface Cable to your laptop.
2. Remove the protective cap from the Digital Wrench® connector.
3. Connect the Vehicle Interface Cable to the Digital Wrench® diagnostic connector.
4. Turn the ignition key to the ‘ON’ position, select the appropriate vehicle and wait for the status to display ‘Connected’ in the lower left corner of the screen.
5. Once connected, proceed with using Digital Wrench®.

## Digital Wrench® Serial Number Location

Open the configuration screen by clicking on the wrench icon. The serial number is located on the right side of the screen.



4.41

# ELECTRONIC FUEL INJECTION

## Digital Wrench® Version and Update ID

Knowing what Digital Wrench® version and update is installed will help determine which updates are required.

**NOTE: Versions and updates are subject to change.**

1. Open the Digital Wrench® software. Locate the version ID shown on the lower right side of the Digital Wrench® start-up screen.



2. Proceed to <http://polaris.diagsys.com> to see if a newer update is available.



3. If a newer update is available, it should be downloaded before using Digital Wrench® (see “Digital Wrench® Updates”).

**NOTE: Always operate with the latest update.**

## 4.42

## Digital Wrench® Updates

Updates are released for Digital Wrench® via the Internet at: <http://polaris.diagsys.com>. The Digital Wrench® website can also be accessed through the dealer website at: [www.polarisdealers.com](http://www.polarisdealers.com).

**NOTE: Only authorized Polaris dealers and distributors can access the dealer website.**

1. Log on to [www.polarisdealers.com](http://www.polarisdealers.com).
2. Locate the “Service and Warranty” drop-down menu.
3. Click on “Digital Wrench Updates”.

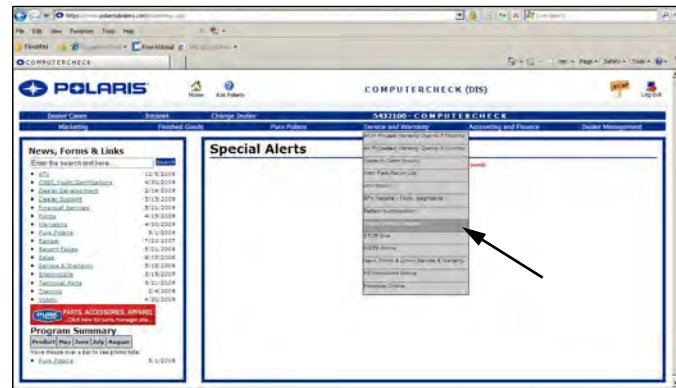

4. The Digital Wrench® portal website should appear in a new web browser.
5. Click on “Digital Wrench Version Updates”.



**NOTE: You must already have the current version installed before adding an update. Updates will not install if you are using an older version loaded on your PC.**

# ELECTRONIC FUEL INJECTION

6. If the update file date listed is newer than your current version and update (see "Digital Wrench® Version and Update ID"), download the file.



8. When the update is complete, the version shown on the right side of the Digital Wrench® start-up screen should match the update you just downloaded.

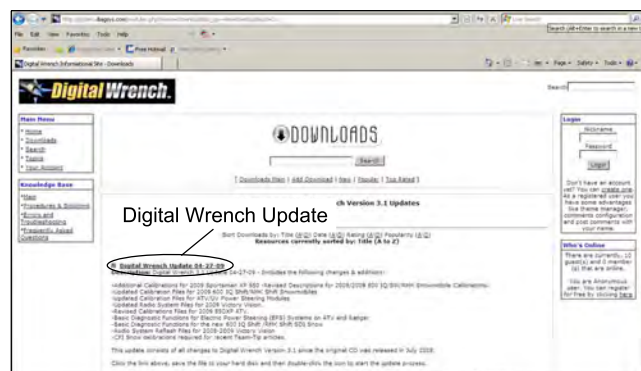

7. Click on the link shown above, save the file to your hard disk and then double-click the icon to start the update process.

**NOTE:** Do not "run" or "open" the file from where they are. Select "save" and download them to your PC before running the install.



**NOTE:** Versions and updates are subject to change.

4



# ELECTRONIC FUEL INJECTION

## Digital Wrench® Feature Map

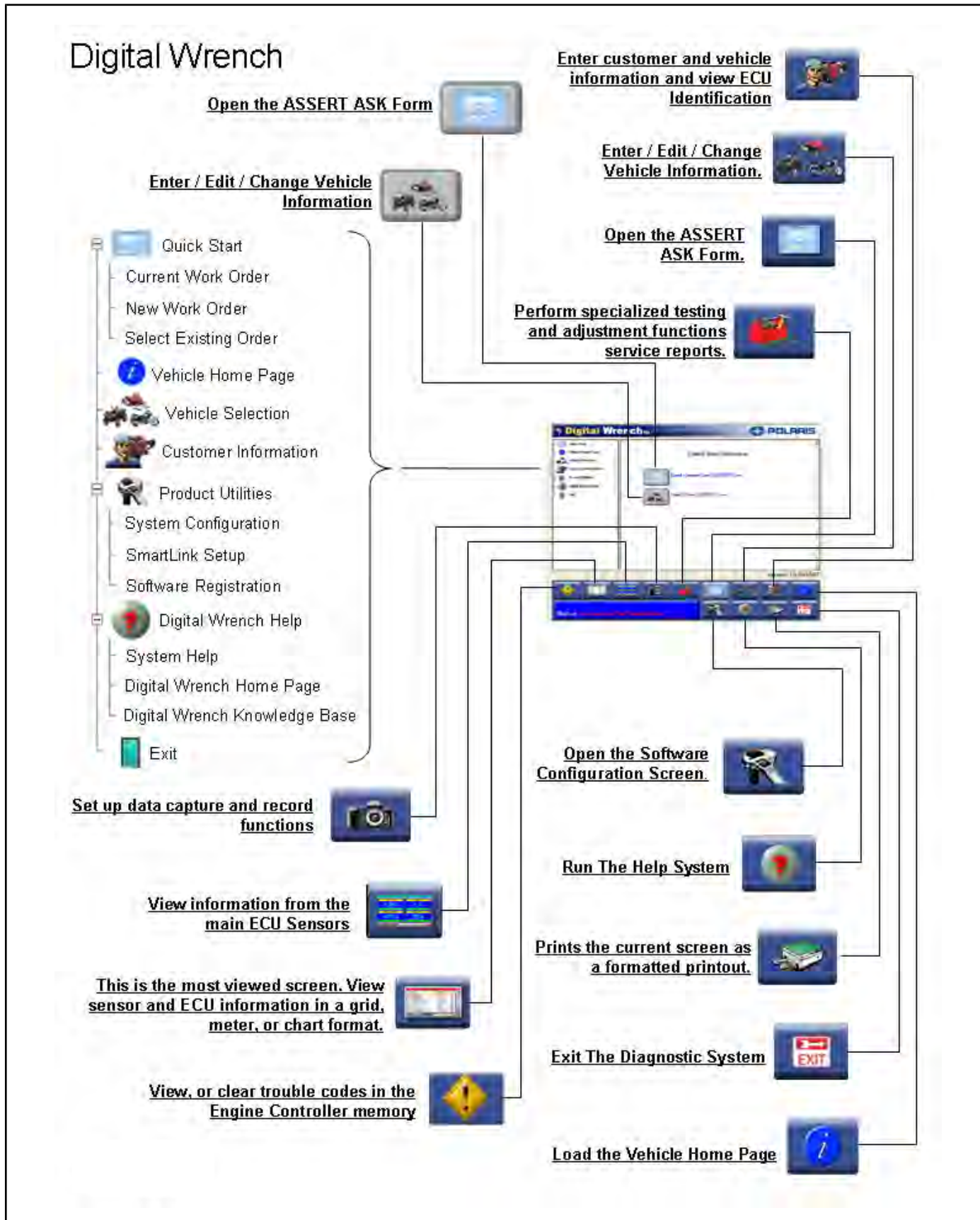

## ECU Replacement

Although the need for ECU replacement is unlikely, a specific replacement procedure is required to ensure that all essential data contained within the original ECU is transferred to the replacement ECU.

Refer to procedure and carefully follow all instructions provided in Digital Wrench®.

## Engine Controller Reprogramming (Reflash)

### Process Overview

The reprogramming feature is in the Special Tests menu on the Digital Wrench® screen. Start Digital Wrench® and click on the Special Tests menu icon (red tool box). A technician should be familiar with the process and with computer operation in general before attempting to reprogram an ECU.

The Digital Wrench® Engine Controller Reprogramming (or “Reflash”) feature allows reprogramming of the ECU fuel and ignition map. To successfully reprogram the ECU, an Authorization Key must be obtained by entering a Request Code in the box provided on the Reflash Authorization site. The Request Code is automatically generated by Digital Wrench® during the reprogramming process. The Reflash Authorization site is located under the “**Service and Warranty**” drop down menu on the dealer website at: [www.polarisdealers.com](http://www.polarisdealers.com).

**NOTE: Failure to follow the reprogramming instructions completely and correctly can result in an engine that does not run! Replacement ECUs are programmed as “no-start” and require a reflash for them to work.**

### Reprogramming (Reflash) Tips:

- **BATTERY VOLTAGE:** The majority of problems with reprogramming can be attributed to a low battery. Be sure the battery voltage (no load) is at least 13 volts and at least 12.5 volts with the key ‘ON’. Connect a battery charger if necessary to bring voltage level above minimum. Fully charge the battery before you attempt to reprogram.
- **DEDICATED LAPTOP:** Best results are obtained using a laptop computer that is “dedicated to Digital Wrench®”. A laptop that is used by a variety of people and in several applications around the dealership is more likely to cause a reprogramming problem than one dedicated to Digital Wrench® diagnostics only.
- **OBTAINING THE LATEST UPDATE:** Reprogramming updates are provided periodically and contain the most recent calibrations (see “Digital Wrench® Updates”).

- **CLOSE NON-ESSENTIAL PROGRAMS:** Polaris recommends that you DO NOT install non-essential programs on a Service Department laptop. Camera detection software, Virus Scanners, Tool Bars, etc. may clog up memory if running in the background and make it harder for the diagnostic software to operate.
- **KNOW THE PROCESS:** If you are not familiar with the entire reprogramming process, review the HELP section of the diagnostic software before you attempt reprogramming. Click on the ? on the tool bar or press F11. The information in the on-line help is the most current and complete information available. This should be your first step until you are familiar with the process.
- **COMMUNICATION PROBLEMS:** If you have had problems communicating with a vehicle while performing diagnostic functions, do not attempt reprogramming until the cause has been identified and fixed. Check all connections, and be sure battery voltage is as specified.
- Proceed to <http://polaris.diaqsys.com> for specific information and FAQs on how to troubleshoot communication problems.

4



- **DON'T DISTURB THE PC:** While reprogramming is in progress, don't move the mouse and don't touch the keyboard. The process only takes a few minutes, and is best left alone until complete.

### Reprogramming (Reflash) Procedure:

If you are not familiar with the reprogramming process, review the “Reprogramming (Reflash) Tips” before you begin. Follow the on-screen instructions as you progress

# ELECTRONIC FUEL INJECTION

through the steps. If you encounter a problem, always check the On-Line help for current tips and information.

1. Verify the most current update has been downloaded and loaded into Digital Wrench®. See, page 4.42
2. Connect SmartLink Module cables to PC and vehicle. See, page 4.41



3. Open the Digital Wrench® program.
4. Select the model year, product line and vehicle description by selecting the “Change Vehicle Type” icon.



5. Select the “Special Tests” icon.

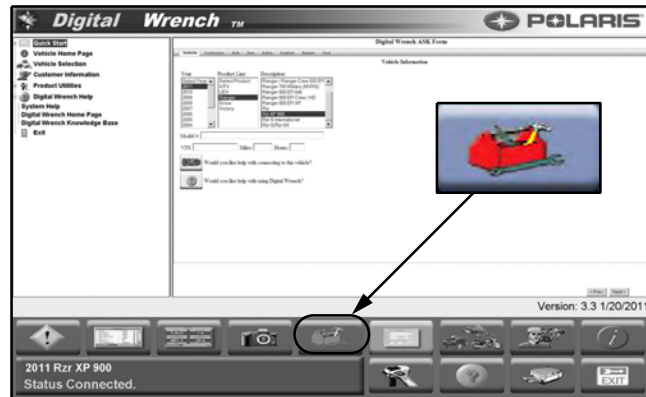

6. Select “Engine Controller Reprogramming”.



7. Select the file you want to load into the ECU then click the “Continue” icon to proceed to the Integrity Check and obtain a Request Code.

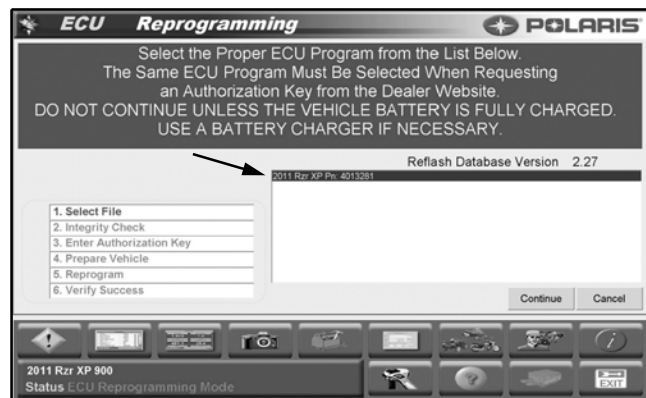

# ELECTRONIC FUEL INJECTION

- Copy (CTRL +C) the Request Code that will be required on the dealer website in the next step. DO NOT CLOSE Digital Wrench® or the Request Code will be invalid. **NOTE: All characters are letters; there are no numbers in a request code.**

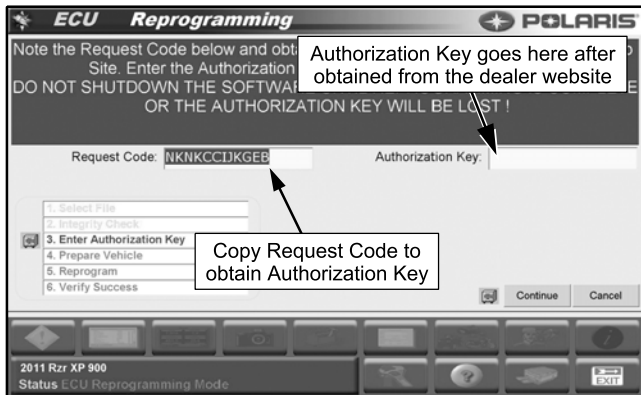

**NOTE: Request Codes and Authorization Keys must be entered EXACTLY as they appear on the screen.**

- Go to [www.polarisdealers.com](http://www.polarisdealers.com) and click on "ReFlash Authorization" from the "Service and Warranty" drop-down menu.

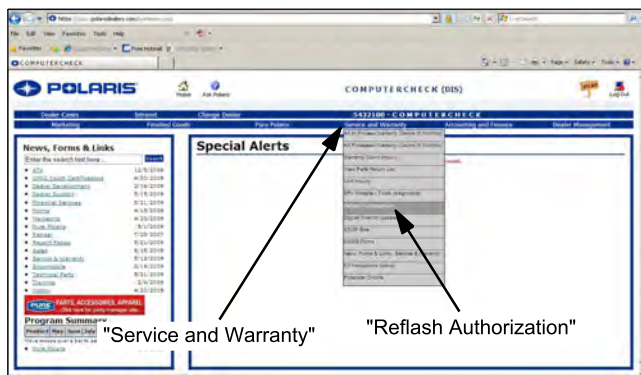

- Enter or paste (CTRL+V) the Request Code into the box.

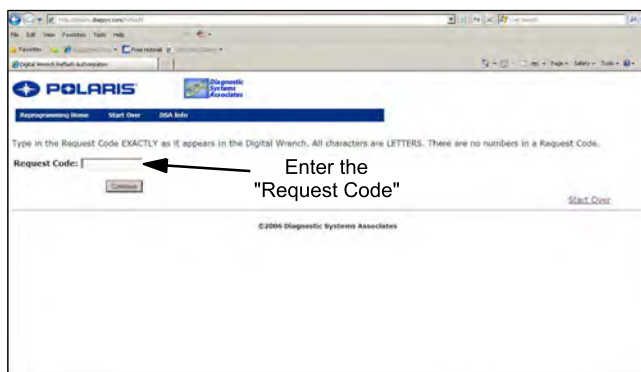

- Select the same file type from the list that you selected previously while in Digital Wrench®. Enter the VIN along with the customer's name and address. When completed, click the Authorize button *once* to proceed.

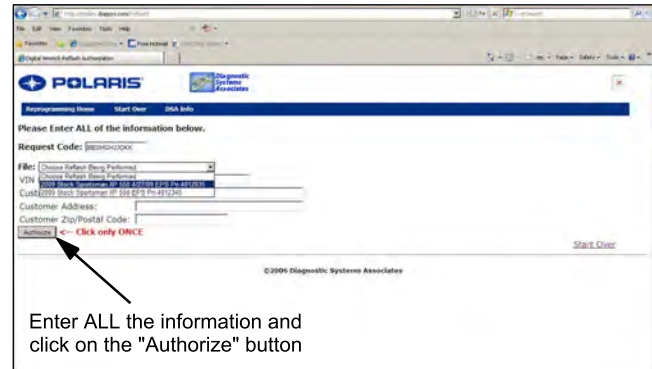

- An "Authorization Key" will appear in the upper left corner of the screen. Copy (CTRL +C) this key exactly as it appears.

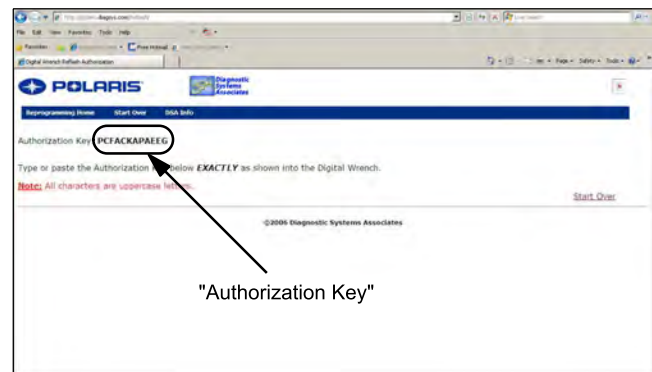

- Enter or paste (CTRL +V) the Authorization Key in the box located on the Digital Wrench® screen. Click the 'Continue' button and follow instructions provided on the screen to complete reprogramming procedure.

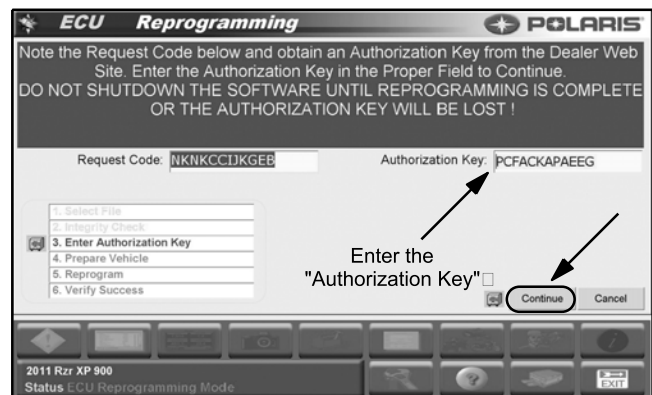

4

## ELECTRONIC FUEL INJECTION

---

14. At this point the reflash process will begin. Do not touch the vehicle or PC during the process.



15. Once the ECU reprogramming procedure is complete, click the 'Finish' button on the screen. Verify the reflash was a success by starting the vehicle.

**CHAPTER 5**  
**BODY / STEERING / SUSPENSION**

GENERAL INFORMATION ..... 5.3  
    SPECIAL TOOLS ..... 5.3  
    MULTI-FUNCTION PLIERS ..... 5.3  
    TORQUE SPECIFICATIONS ..... 5.4  
BODY ASSEMBLY VIEWS ..... 5.5  
    CAB FRAME ASSEMBLY XP ..... 5.5  
    CAB FRAME ASSEMBLY XP 4 ..... 5.6  
    DOORS XP ..... 5.7  
    DOORS XP 4 ..... 5.8  
    DASH INSTRUMENTS / CONTROLS ..... 5.9  
    HOOD / FRONT BODY WORK ..... 5.10  
    CHASSIS / MAIN FRAME XP ..... 5.11  
    CHASSIS / MAIN FRAME XP 4 ..... 5.12  
    SEAT ASSEMBLY FRONT ..... 5.13  
    SEAT ASSEMBLY REAR ..... 5.14  
    FLOOR / ROCKER PANELS XP ..... 5.15  
    FLOOR / ROCKER PANELS XP 4 ..... 5.16  
    REAR CARGO BOX / FENDERS ..... 5.17  
    REAR BUMPER ..... 5.18  
BODY COMPONENT REMOVAL ..... 5.19  
    SEATS ..... 5.19  
    ENGINE SERVICE PANEL ..... 5.19  
    FRONT BUMPER XP ..... 5.19  
    REAR BUMPER ..... 5.19  
    HOOD AND FRONT BODY WORK ..... 5.20  
    REAR FENDER / FENDER FLARE REMOVAL ..... 5.21  
    REAR FENDER FLARE / REAR FENDER REMOVAL XP 4 ..... 5.21  
    CARGO BOX ASSEMBLY REMOVAL ..... 5.21  
    ROCKER PANELS, CONSOLE AND FLOOR XP ..... 5.22  
    ROCKER PANELS, REAR CONSOLE AND FLOOR XP 4 ..... 5.23  
    DECAL REPLACEMENT ..... 5.26  
STEERING ASSEMBLY ..... 5.27  
    ASSEMBLY VIEW (NON-EPS MODELS) ..... 5.27  
    STEERING WHEEL REMOVAL (NON-EPS MODELS) ..... 5.28  
    STEERING SHAFT REMOVAL (NON-EPS MODELS) ..... 5.28  
    STEERING SHAFT BEARING REPLACEMENT ..... 5.28  
ELECTRONIC POWER STEERING ASSEMBLY ..... 5.30  
    ASSEMBLY VIEW (EPS MODELS) ..... 5.30  
    UPPER STEERING SHAFT REMOVAL (EPS MODELS) ..... 5.31  
    STEERING WHEEL REMOVAL (EPS MODELS) ..... 5.31  
    POWER STEERING UNIT REMOVAL ..... 5.32  
    LOWER STEERING SHAFT REMOVAL (EPS MODELS) ..... 5.33

## BODY / STEERING / SUSPENSION

---

LOWER STEERING SHAFT INSTALLATION (EPS MODELS) .....	5.33
POWER STEERING UNIT INSTALLATION .....	5.34
UPPER STEERING SHAFT INSTALLATION (EPS MODELS) .....	5.34
FRONT A-ARMS .....	5.36
REMOVAL / REPLACEMENT .....	5.36
BALL JOINT SERVICE .....	5.39
SERVICE PREPARATION .....	5.39
BALL JOINT REMOVAL .....	5.39
BALL JOINT INSTALLATION .....	5.39
REAR RADIUS RODS .....	5.40
REMOVAL / INSTALLATION .....	5.40
REAR TRAILING ARM .....	5.41
TRAILING ARM REMOVAL / INSTALLATION .....	5.41
TRAILING ARM SPHERICAL BEARING REPLACEMENT .....	5.43
REAR SUSPENSION ASSEMBLY VIEW .....	5.44
REAR STABILIZER BAR .....	5.45
STABILIZER BAR REMOVAL .....	5.45
STABILIZER BAR INSTALLATION .....	5.45
SHOCKS / SPRINGS / FASTENERS .....	5.46
FRONT SHOCK ASSEMBLY VIEW .....	5.46
REAR SHOCK ASSEMBLY VIEW .....	5.46
SHOCK REMOVAL / INSTALLATION .....	5.47
SHOCK REPLACEMENT .....	5.47
WALKER EVANS™ SHOCK ASSEMBLY VIEWS .....	5.48
WALKER EVANS™ 2.0" FRONT SHOCK .....	5.48
WALKER EVANS™ 2.5" REAR SHOCK .....	5.49
WALKER EVANS™ SHOCK SERVICE .....	5.50
GENERAL SERVICE INFORMATION .....	5.50
FRONT SHOCK SERVICE INFORMATION .....	5.50
REAR SHOCK SERVICE INFORMATION .....	5.51
WALKER EVANS™ SHOCK REBUILD INFORMATION .....	5.52
SPECIAL TOOLS .....	5.52
VALVE SHIM ARRANGEMENT .....	5.52
PISTON ORIENTATION .....	5.52
WALKER EVANS™ SHOCK DISASSEMBLY .....	5.53
WALKER EVANS™ SHOCK ASSEMBLY .....	5.55

## GENERAL INFORMATION

### SPECIAL TOOLS

PART NUMBER	TOOL DESCRIPTION
2200421	Gas Shock Recharging Kit
2878925	Shock Spring Preload Spanner Wrench (Walker Evans™)
2876389	Multi-Function Pliers

**Walker Evans™:** See Walker Evans™ Shock Service later in this chapter, page 5.52

**Bosch Automotive Service Solutions:** 1-800-345-2233 or <http://polaris.service-solutions.com>

### Multi-Function Pliers

Included in the tool kit, the multi-function pliers is designed to remove the plastic push rivets used to fasten body components.

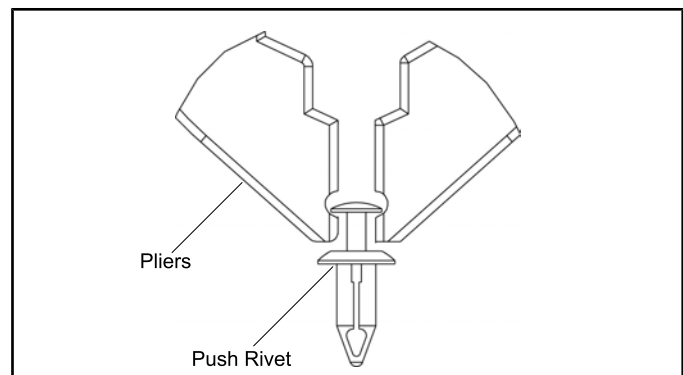
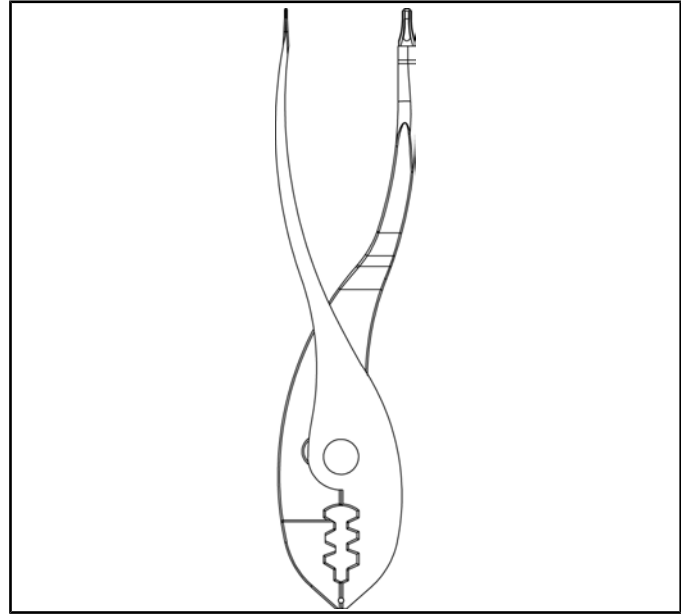



## BODY / STEERING / SUSPENSION

### TORQUE SPECIFICATIONS

ITEM	TORQUE VALUE
Front A-Arm Bolt	42 ft-lb (57 Nm)
Door Hinge Mount Nuts	8 ft-lb (11 Nm)
Door Latch Screws	8 ft-lb (11 Nm)
Tie Rod End to Bearing Carrier Housing Bolt (Not reusable)	15 ft-lbs (20 Nm) + 90°
Ball Joint Fastener	42 ft-lbs (57 Nm)
Front Shock Mount Bolts	44 ft-lb (60 Nm)
Rear Shock Mount Bolts	70 ft-lbs (95 Nm)
Front Bumper / Fender Screws	8 ft-lb (11 Nm)
Floor Screws	8 ft-lb (11 Nm)
Wheel Hub Castle Nuts	110 ft-lbs (149 Nm)
Wheel Nuts (Cast Aluminum Rims)	120 ft-lbs (163 Nm)
Tie Rod End Jamb Nut	14 ft-lbs (19 Nm)
Radius Rod Fasteners	40 ft-lb (54 Nm)
Trailing Arm to Frame Bolt	70 ft-lb (95 Nm)
Bearing Carrier to Trailing Arm Bolts	42 ft-lb (54 Nm)
Rear Stabilizer Bar Linkage	40 ft-lbs (54 Nm)
Rear Shock Reservoir Mounting Clamps	35 in-lb (4 Nm)
Rear Stabilizer Bar Mounting Bracket Bolts	17 ft-lb (23 Nm)
Rear Stabilizer Bar Locating Clamp Bolts	10 ft-lb (14 Nm)
Seat Belt Mounting Hardware	40 ft-lbs (54 Nm)
Seat Slider Plate	4 ft-lb (5 Nm)
Shock Guard Screws	14 in-lbs (2 Nm)
Skid Plate Screws	8 ft-lbs (11 Nm)
Front to Rear Frame Bolts	40 ft-lb (54 Nm)
Tilt Steering Shock Fasteners	7 ft-lb (10 Nm)
Steering Pivot Tube Mounting Fasteners	8 ft-lb (11 Nm)

ITEM	TORQUE VALUE
Steering Wheel Nut	65 ft-lbs (88 Nm)
Steering Shaft to Power Steering Unit (upper/lower) (EPS models)	15 ft-lbs (20 Nm)
EPS Cover Screws	8 ft-lb (11 Nm)
Power Steering Unit to Mount Bracket Bolts	30 ft-lb (41 Nm)
Lower Steering Shaft to Steering Rack	42 ft-lb (57 Nm)
Power Steering Bracket to Frame Nuts	16 ft-lb (22 Nm)
Steering Rack Mounting Bolts	16 ft-lbs (22 Nm)
Cab Frame Bolts	40 ft-lb (54 Nm)
Hip Bolster Bolts	14 ft-lb (19 Nm)
Visor Mounting Screws	8 ft-lb (11 Nm)
Seat Base to Frame (Front Bolts)	14 ft-lb (19 Nm)
Seat Base to Frame (Rear Bolts)	30 ft-lb (41 Nm)

## BODY ASSEMBLY VIEWS

### Cab Frame Assembly XP

**NOTE:** Finger tighten all components until cab frame is completely assembled on vehicle then tighten to specification.

1. Install hip bolster and secure the bottom mount with M8 x 1.24 x 20 bolts. Torque bolts to **14 ft-lb (19 Nm)**.
2. Install ROPS hoop to the hip bolster and frame with M10 x 1.25 x 55 bolts and nuts. Tighten fasteners to **40 ft-lb (54 Nm)** (**54 Nm**)
3. Install the front ROPS to the frame with M10 x 1.5 x 45 screws and nuts. Install front ROPS to ROPS hoop with M10 x 1.5 x 20 screws. Torque fasteners to **40 ft-lb (54 Nm)**.
4. Install rear ROPS to the ROPS hoop with M10 x 1.5 x 25 screws. Install rear ROPS to frame with M10 x 1.5 x 45 screws and nuts. Torque fasteners to **40 ft-lb (54 Nm)**.
5. Install deflector on front ROPS with M10 x 1.25 x 20 bolts. Torque bolts to **8 ft-lb (11 Nm)**

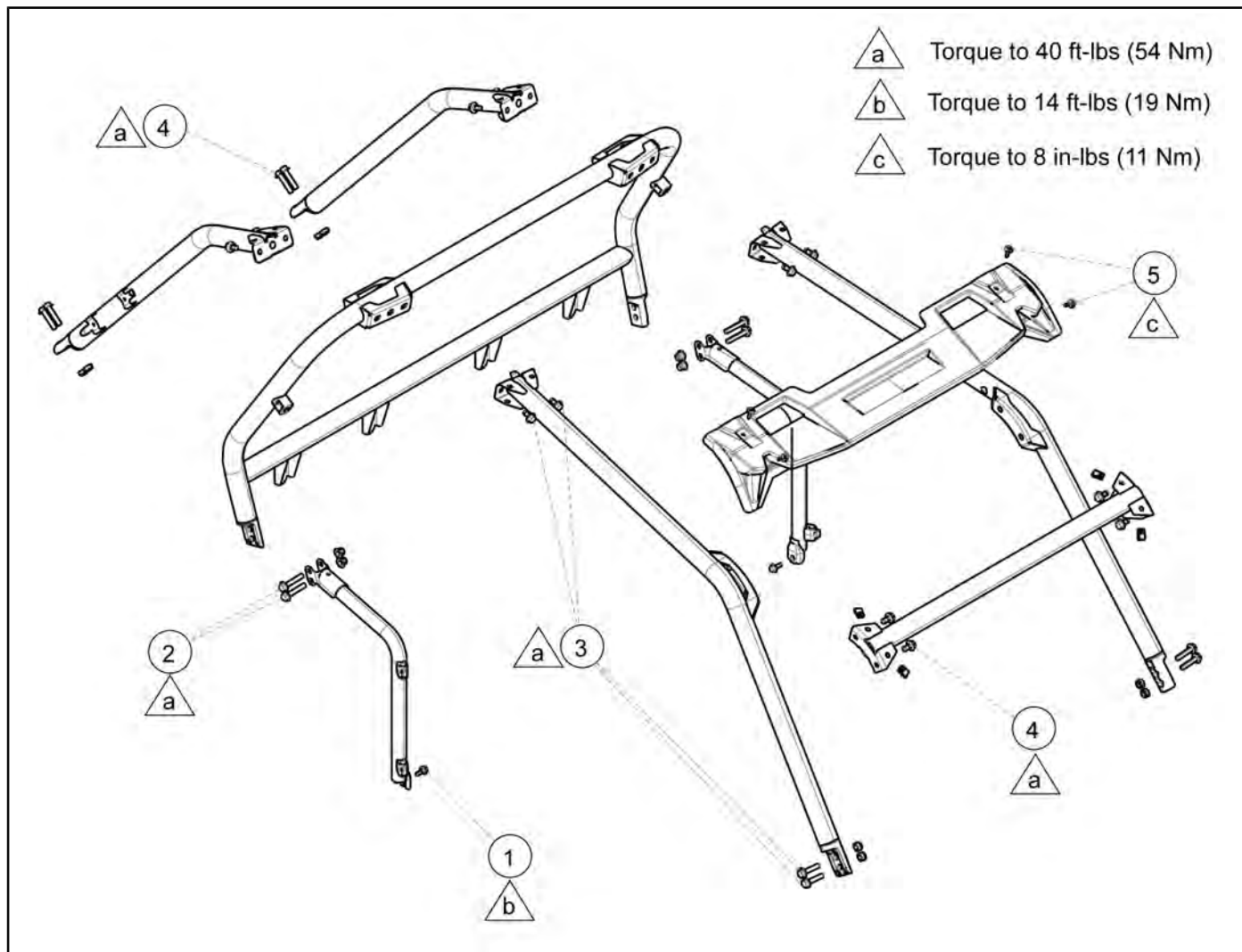

## BODY / STEERING / SUSPENSION

### Cab Frame Assembly XP 4

**NOTE:** Finger tighten all components until cab frame is completely assembled on vehicle then tighten to specification.

1. Install the ROPS mid-hoop to the frame with M10 x 1.5 x 65 screws and nuts (item 1). Torque to **40 ft-lb (54 Nm)**.
2. Install hip bolsters onto the main frame with M8 x 1.25 x 20 bolts (item 2). Torque bolts to **14 ft-lb (19 Nm)**
3. Install ROPS rear hoop to frame with M10 x 1.25 x 55 bolts and nuts (item 3). Torque to **40 ft-lb (54 Nm)**
4. Attach ROPS main to the mid ROPS hoop and front main frame with M10 x 1.5 x 45 screws (item 4). Torque to **40 ft-lb (54 Nm)**.
5. Install rear ROPS to rear ROPS hoop and rear frame with M10 x 1.5 x 45 screws (item 5). Torque to **40 ft-lb (54 Nm)**
6. Install ROPS brace to ROPS mid hoop and ROPS rear hoop with M10 x 1.5 x 45 screws (item 6). Torque to **40 ft-lb (54 Nm)**
7. Install ROPS front to ROPS mains with M10 x 1.5 x 20 screws (item 7). Torque to **40 ft-lb (54 Nm)**
8. Install visor panel on front ROPS with M10 x 1.25 x 20 bolts. Torque to **8 ft-lb (11 Nm)**

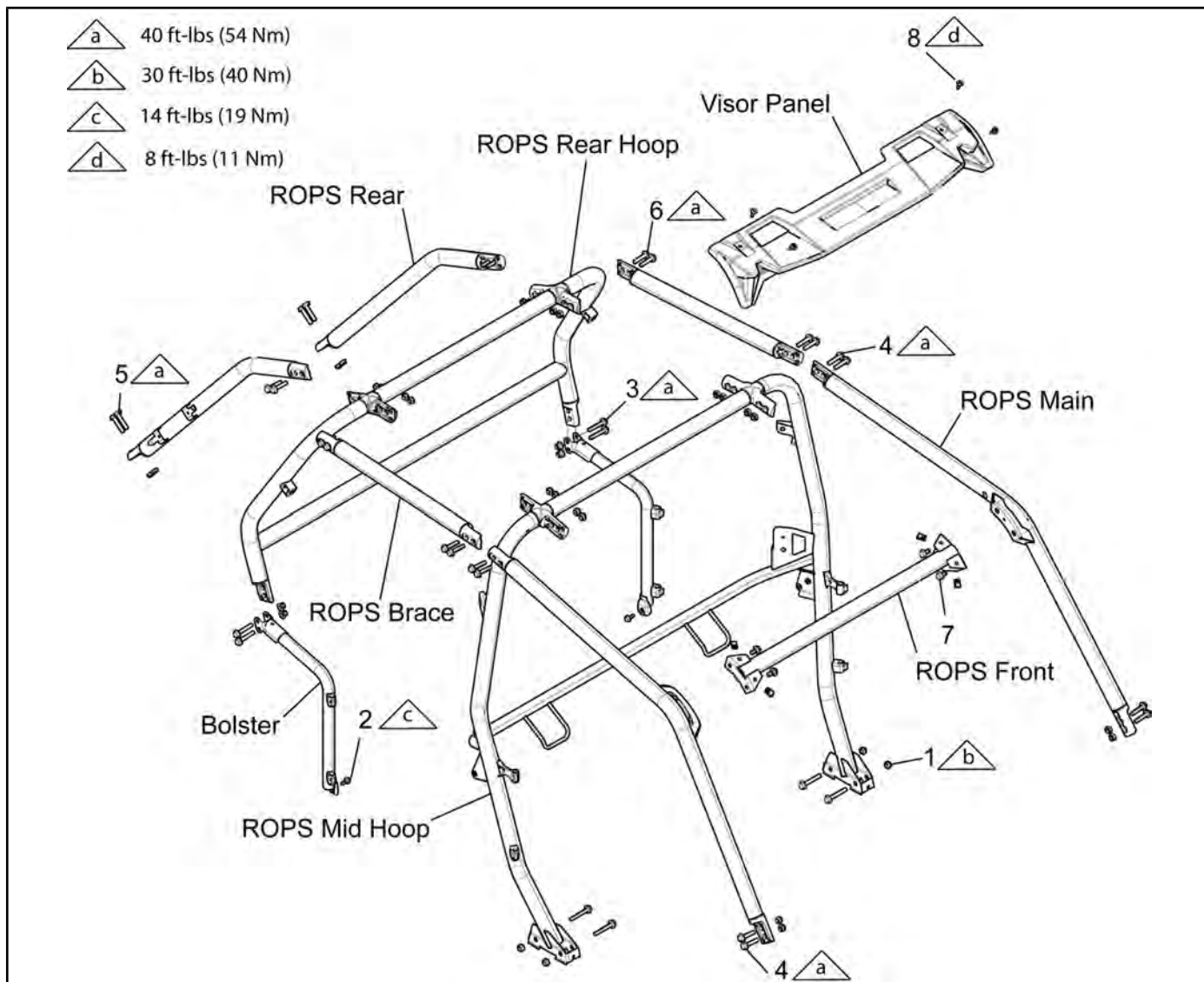

## Doors XP

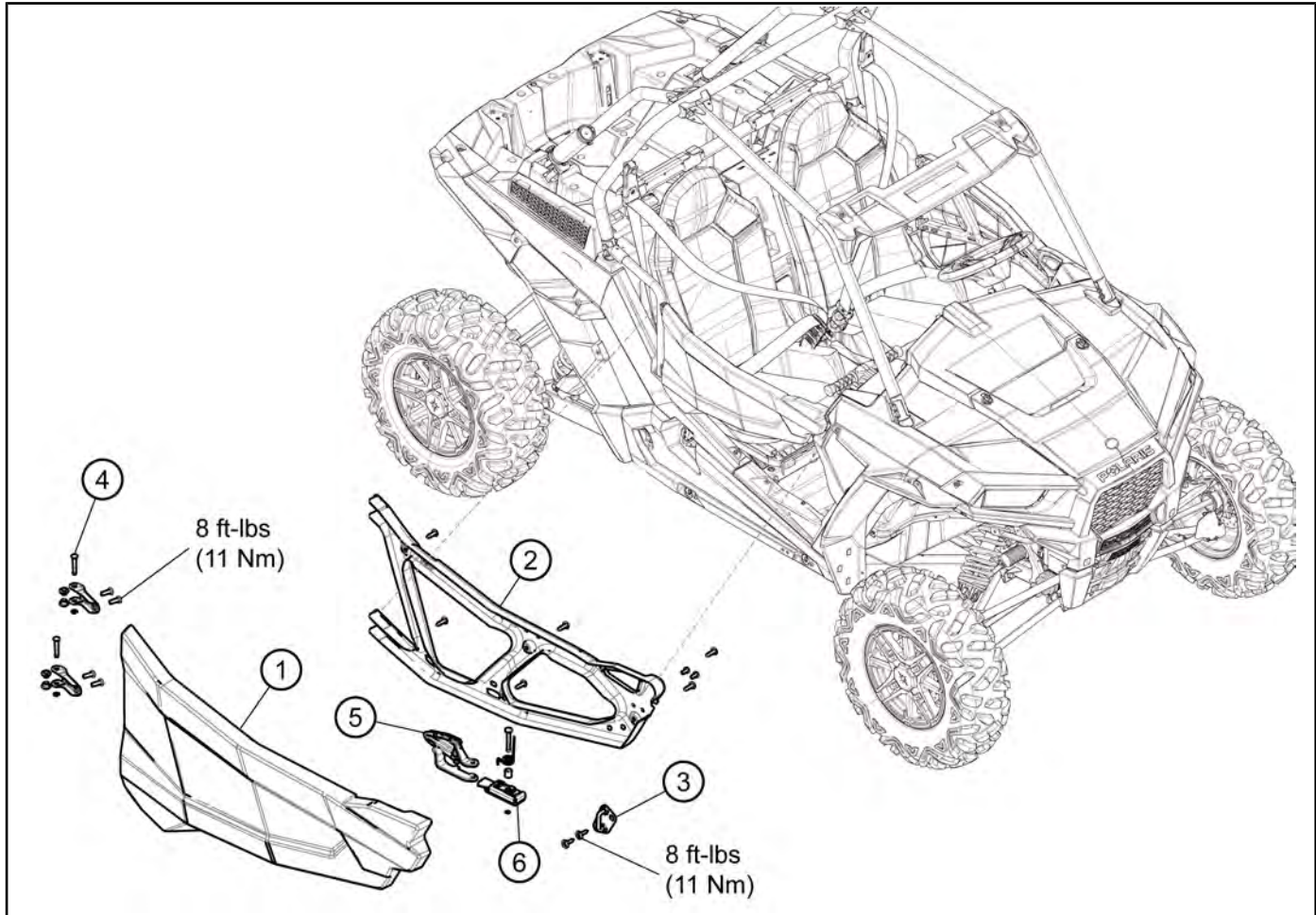

1. Door Panel	4. Hinge Pin
2. Door Frame	5. Latch Release
3. Latch Striker	6. Latch

# BODY / STEERING / SUSPENSION

## Doors XP 4

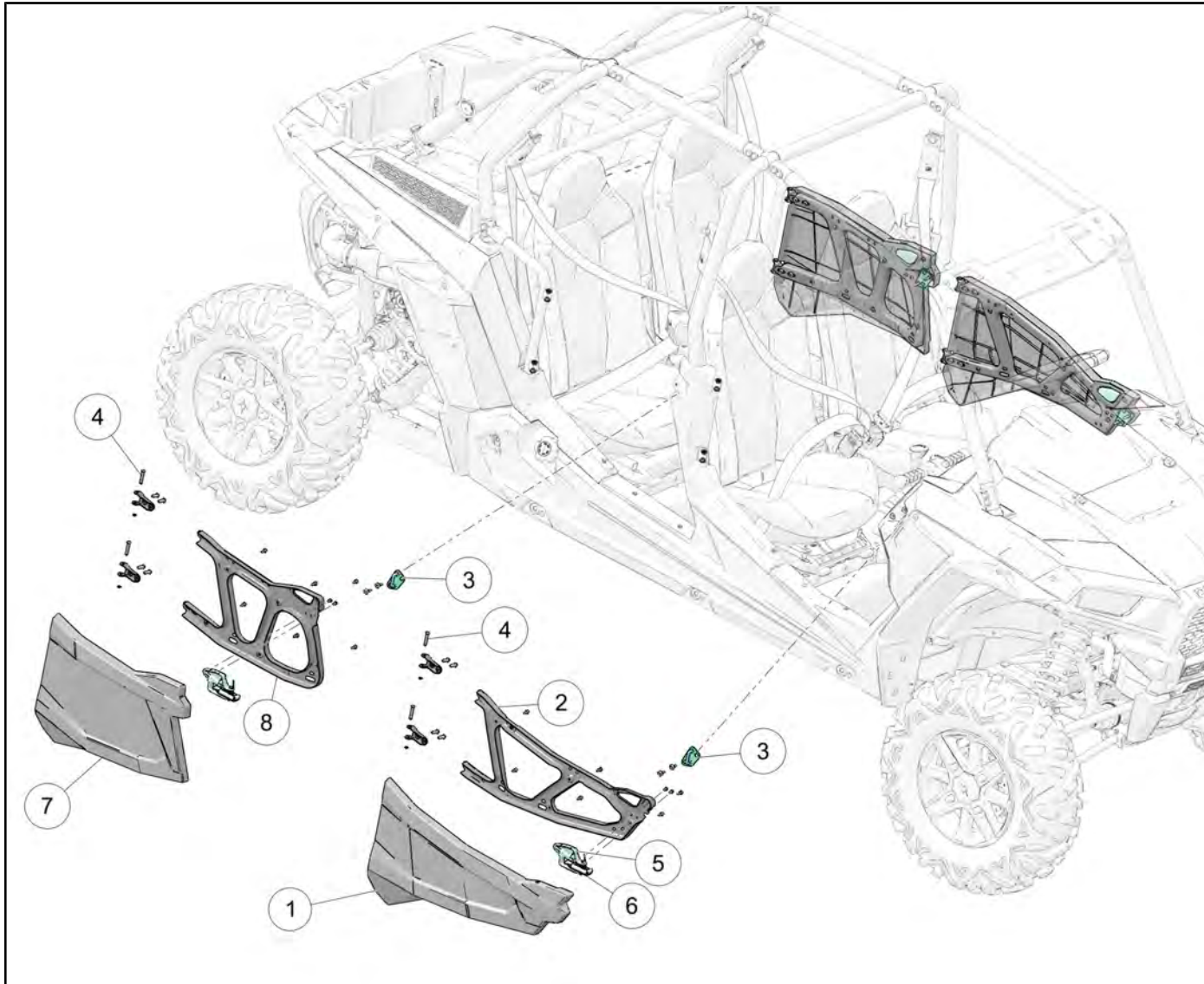

1. Door Panel	4. Hinge Pin
2. Door Frame	5. Latch Release
3. Latch Striker	6. Latch
7. Door Panel (Rear)	8. Door Frame (Rear)

## Dash Instruments / Controls

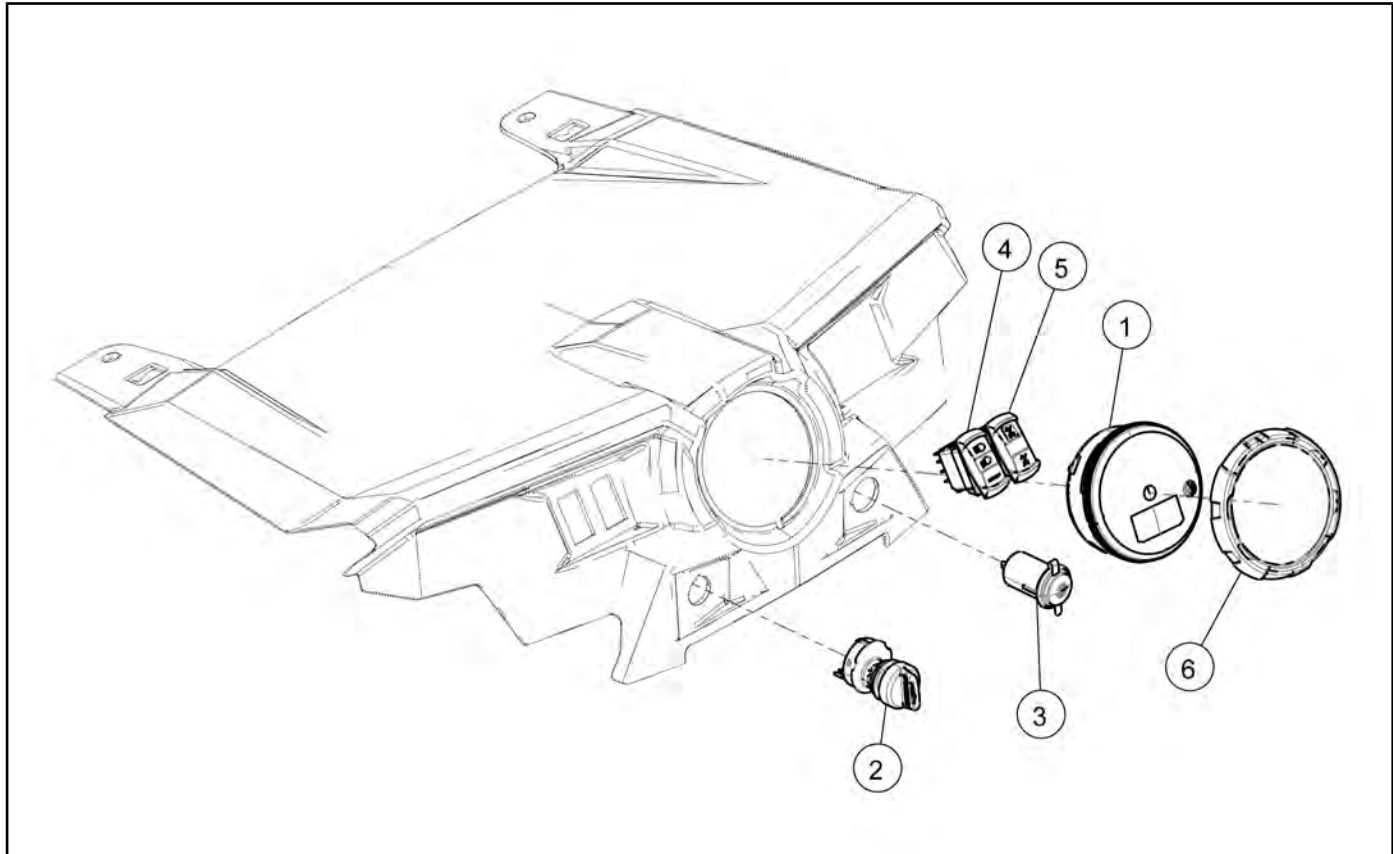

5

1. Instrument Cluster	4. Headlight Switch
2. Key Switch	5. AWD Switch
3. 12V Accessory Port	6. Bezel

# BODY / STEERING / SUSPENSION

## Hood / Front Body Work

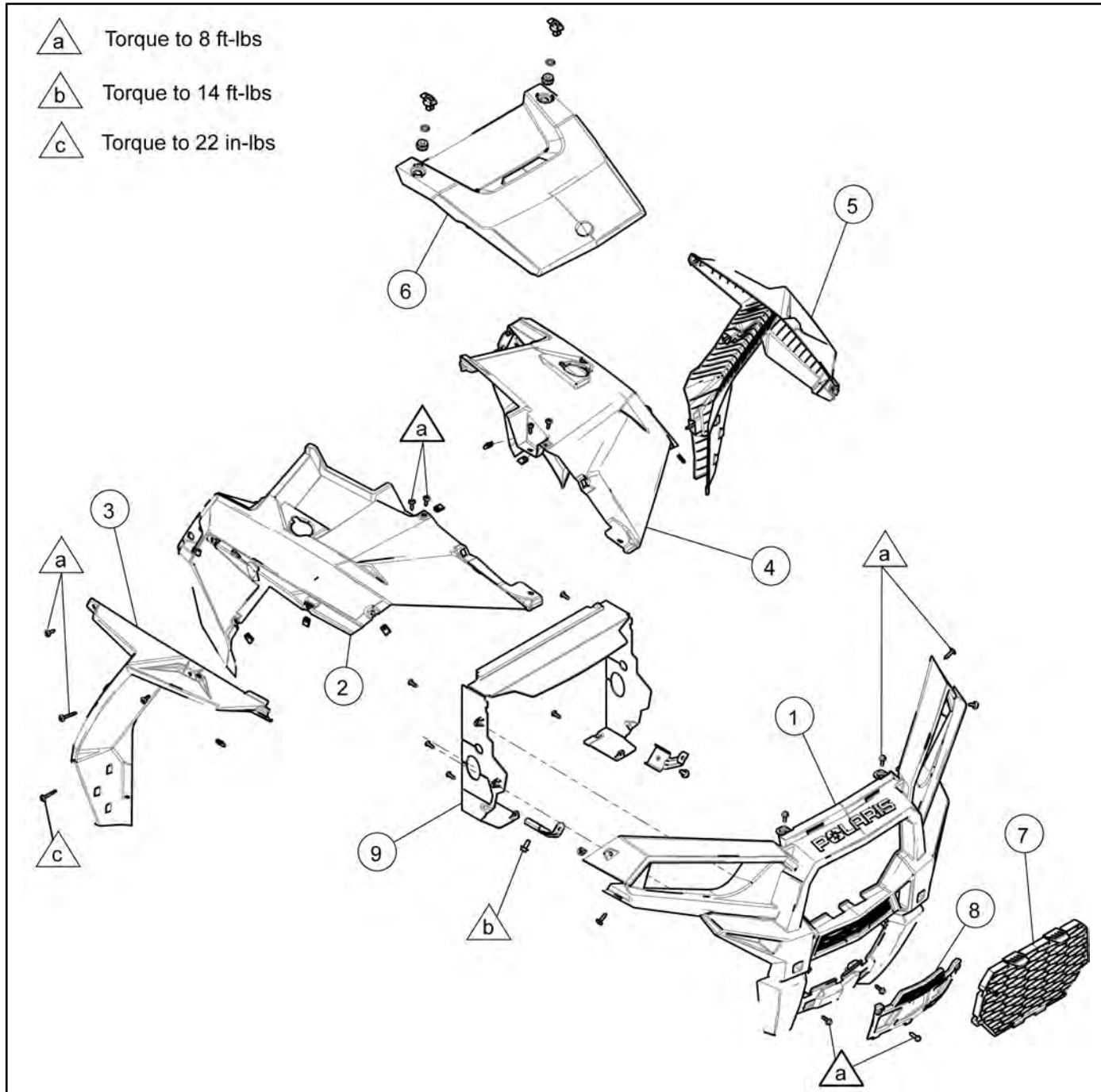

1. Front Bumper	6. Hood
2. Right Front Fender	7. Grill
3. Right Front Fender Flair	8. Front Bumper Cover
4. Left Front Fender	9. Radiator Shroud
5. Left Front Fender Flair	

### 5.10

## Chassis / Main Frame XP

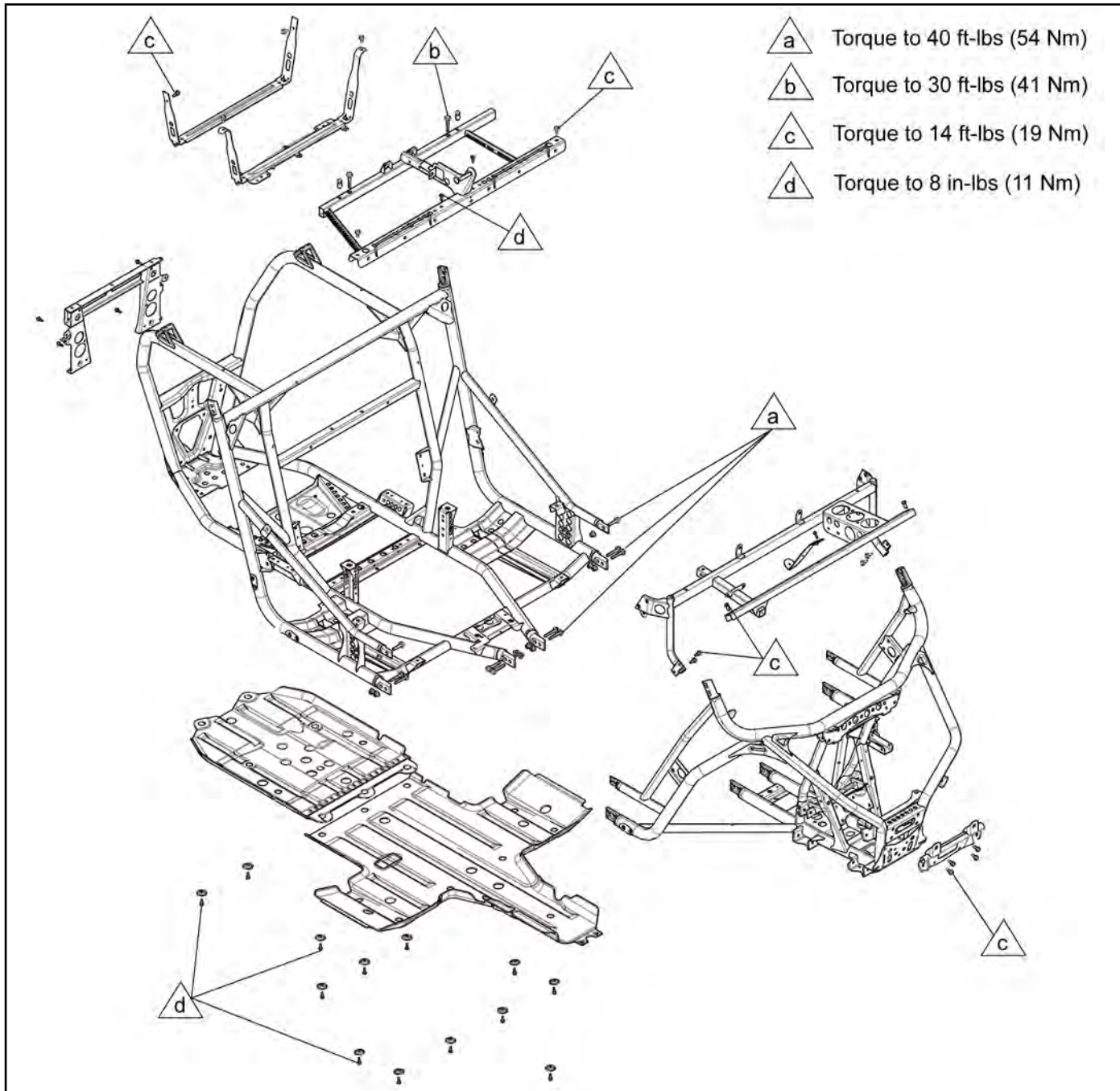



# BODY / STEERING / SUSPENSION

## Chassis / Main Frame XP 4

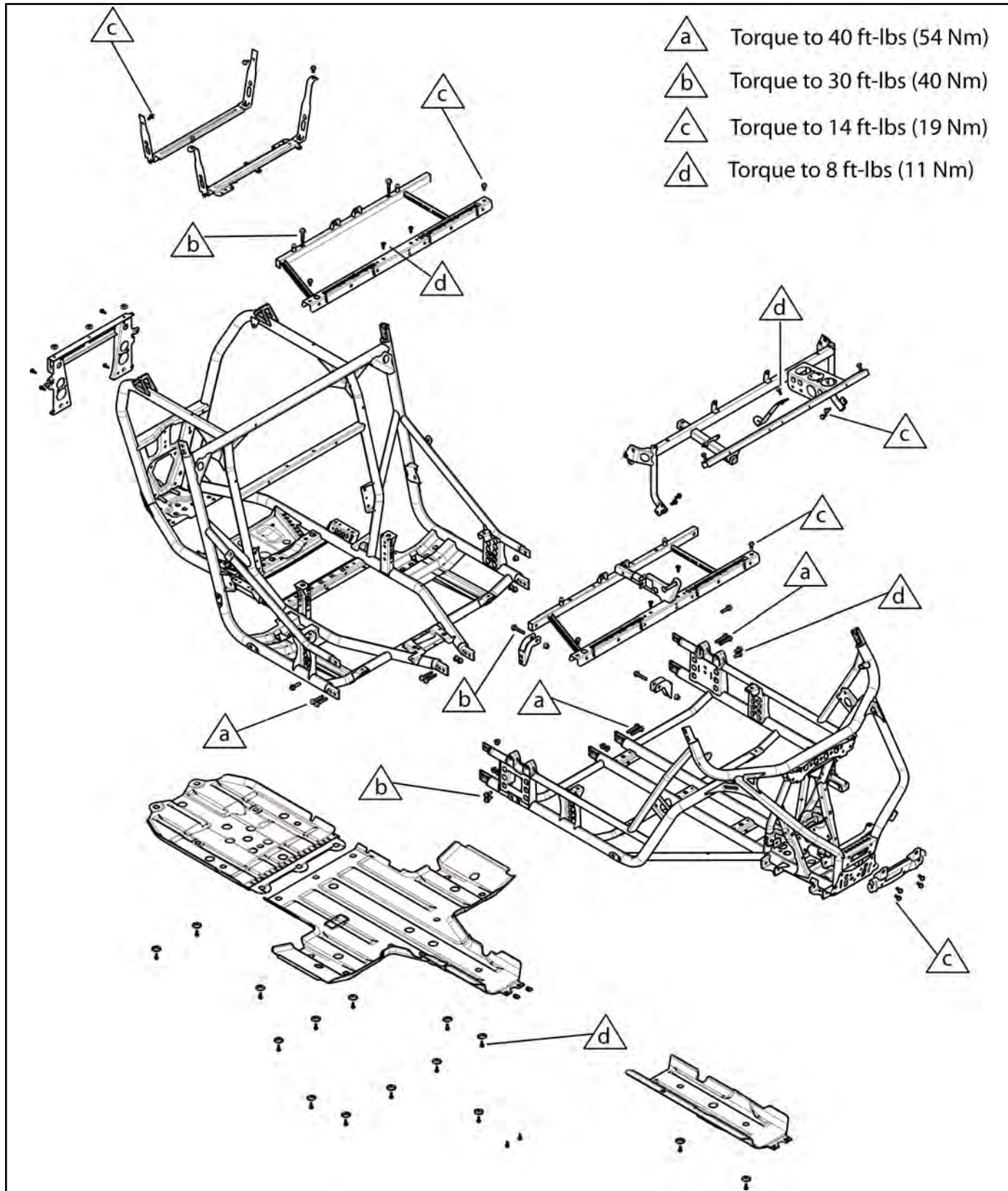



## BODY / STEERING / SUSPENSION

### Seat Assembly Rear

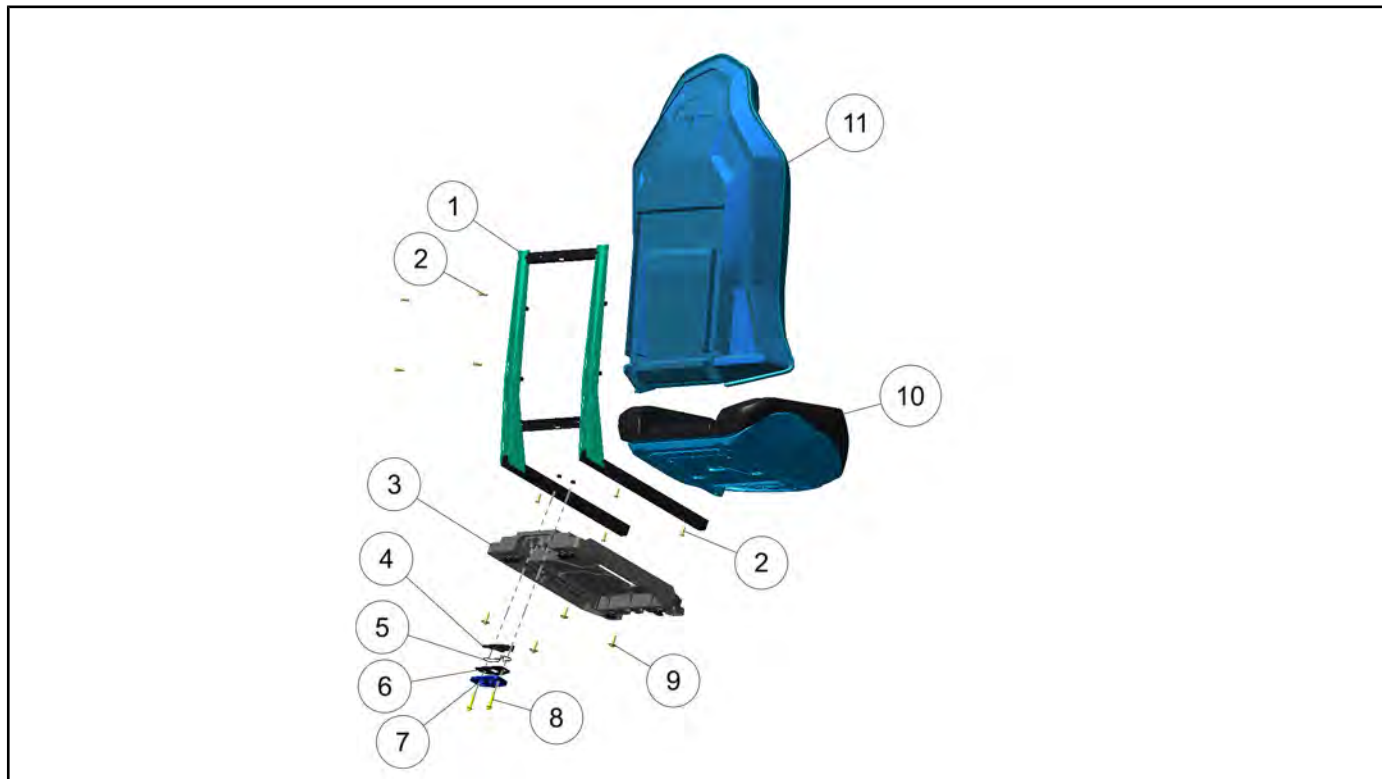

1. Seat Frame	7. Plate Seat Latch
2. Screw <b>4 ft-lb (5 Nm)</b>	8. Screw <b>4 ft-lb (5 Nm)</b>
3. Seat Base Assembly	9. Bolt
4. Seat Latch Lever	10. Seat Bottom
5. Spring Seat Latch	11. Seat Back
6. Plate Seat Latch	

## Floor / Rocker Panels XP

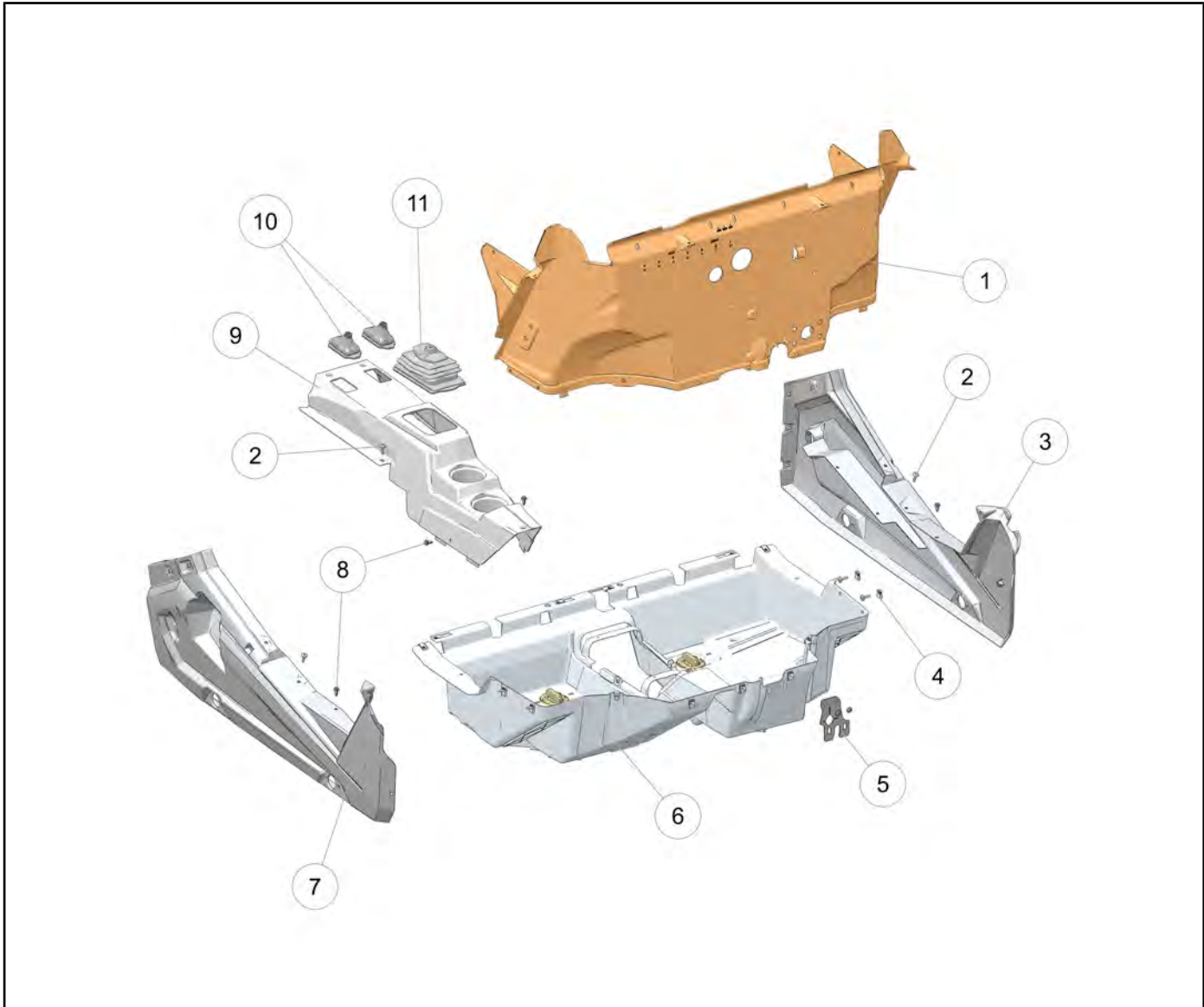

5

1. Upper Floor	7. RH Rocker
2. T27 Screws	8. Push Rivots
3. LH Rocker	9. Console Cover
4. U-Type Nuts	10. Seat Belt Boot
5. Block Off Flap	11. Shifter Boot
6. Lower Floor	

# BODY / STEERING / SUSPENSION

## Floor / Rocker Panels XP 4

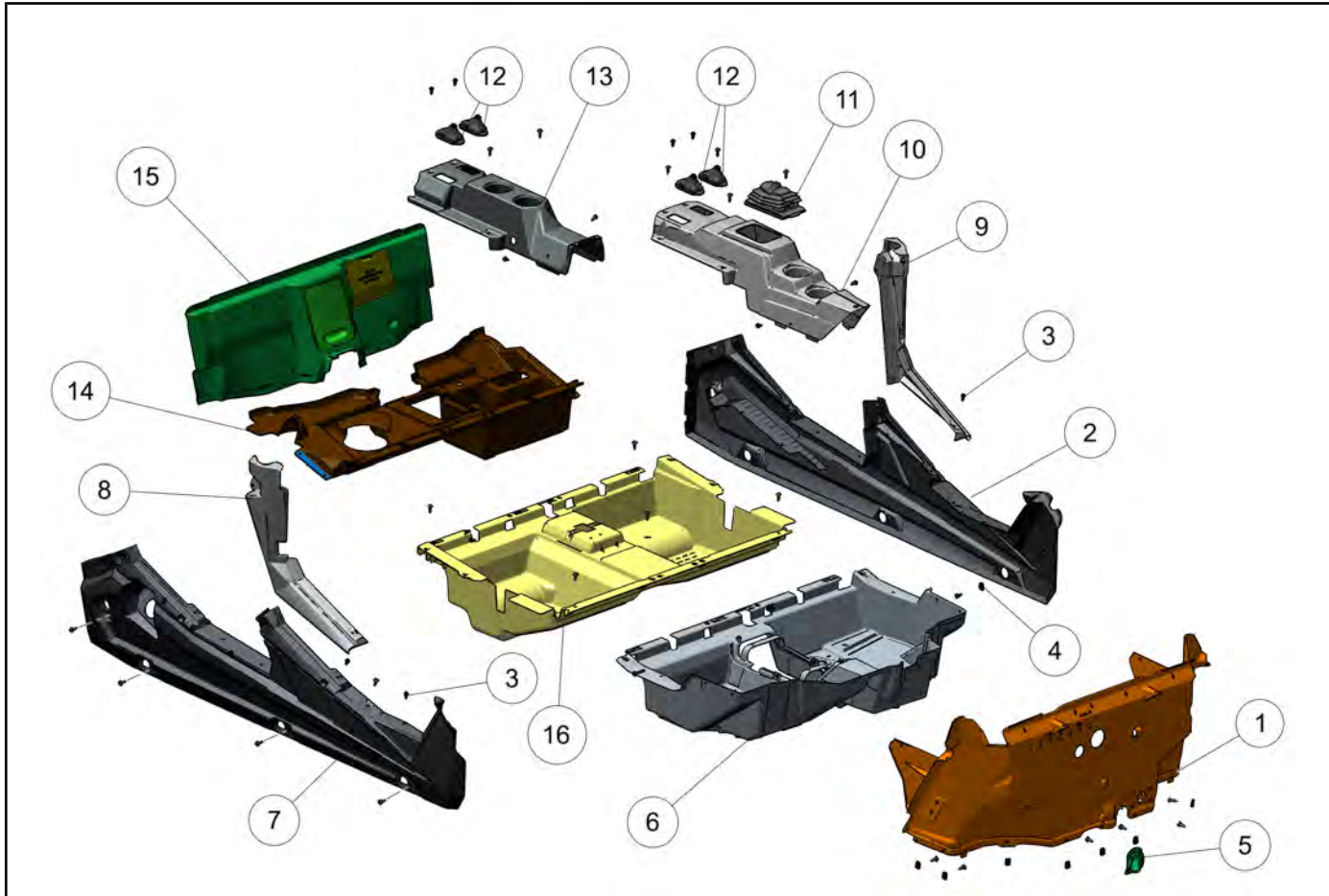

1. Main Floor Upper	9. B-Pillar Cover LH
2. Rocker LH	10. Console Front
3. Rivet	11. Shifter Boot
4. U-Type Nuts	12. Seat Belt Boot Front
5. Block Off Flap	13. Console Rear
6. Main Floor Lower	14. Lower Rear Close-off Panel
7. Rocker RH	15. Upper Rear Close-off Panel
8. B-Pillar Cover RH	16. Floor Rear

## Rear Cargo Box / Fenders

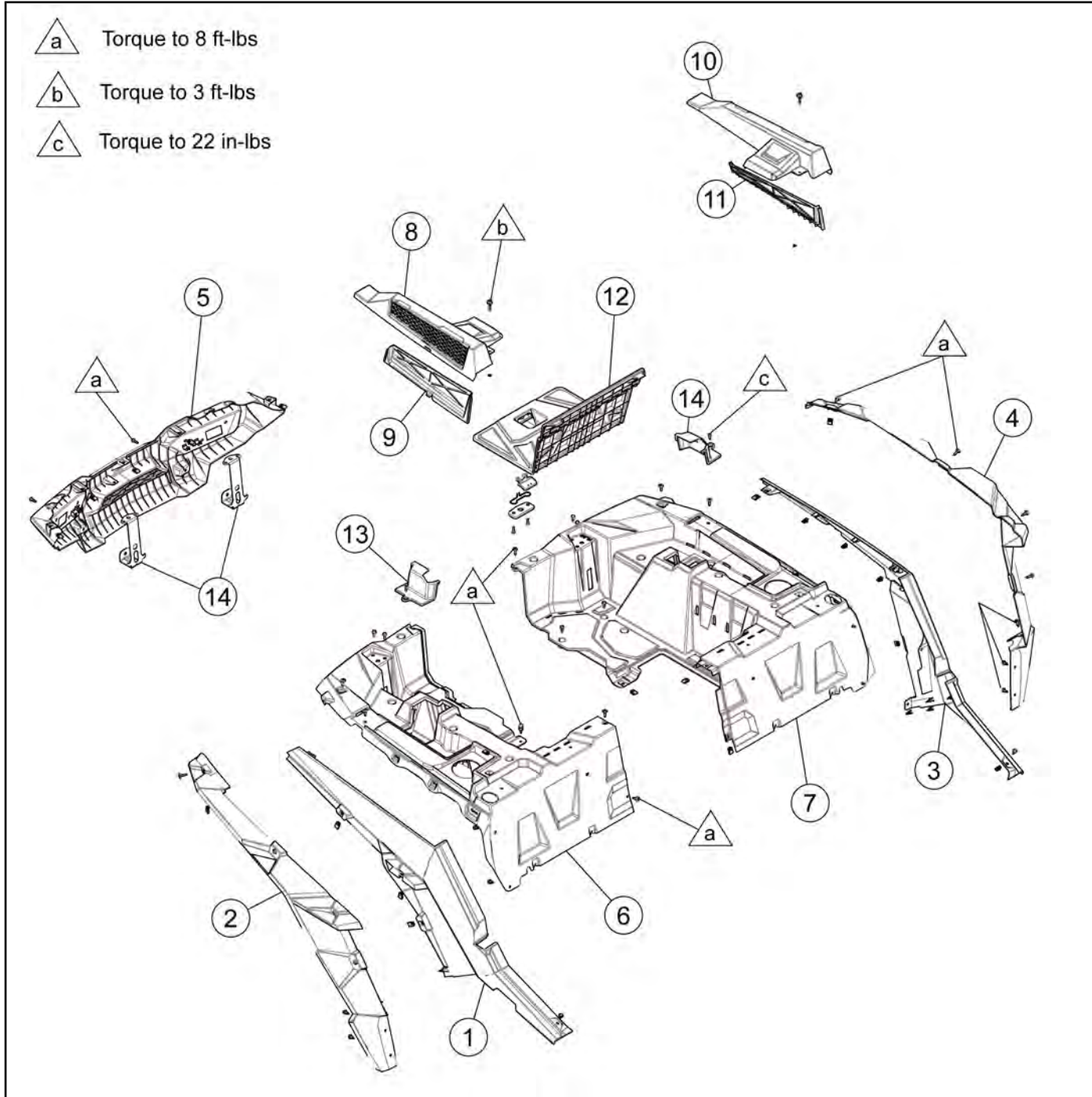

# BODY / STEERING / SUSPENSION

## Rear Bumper

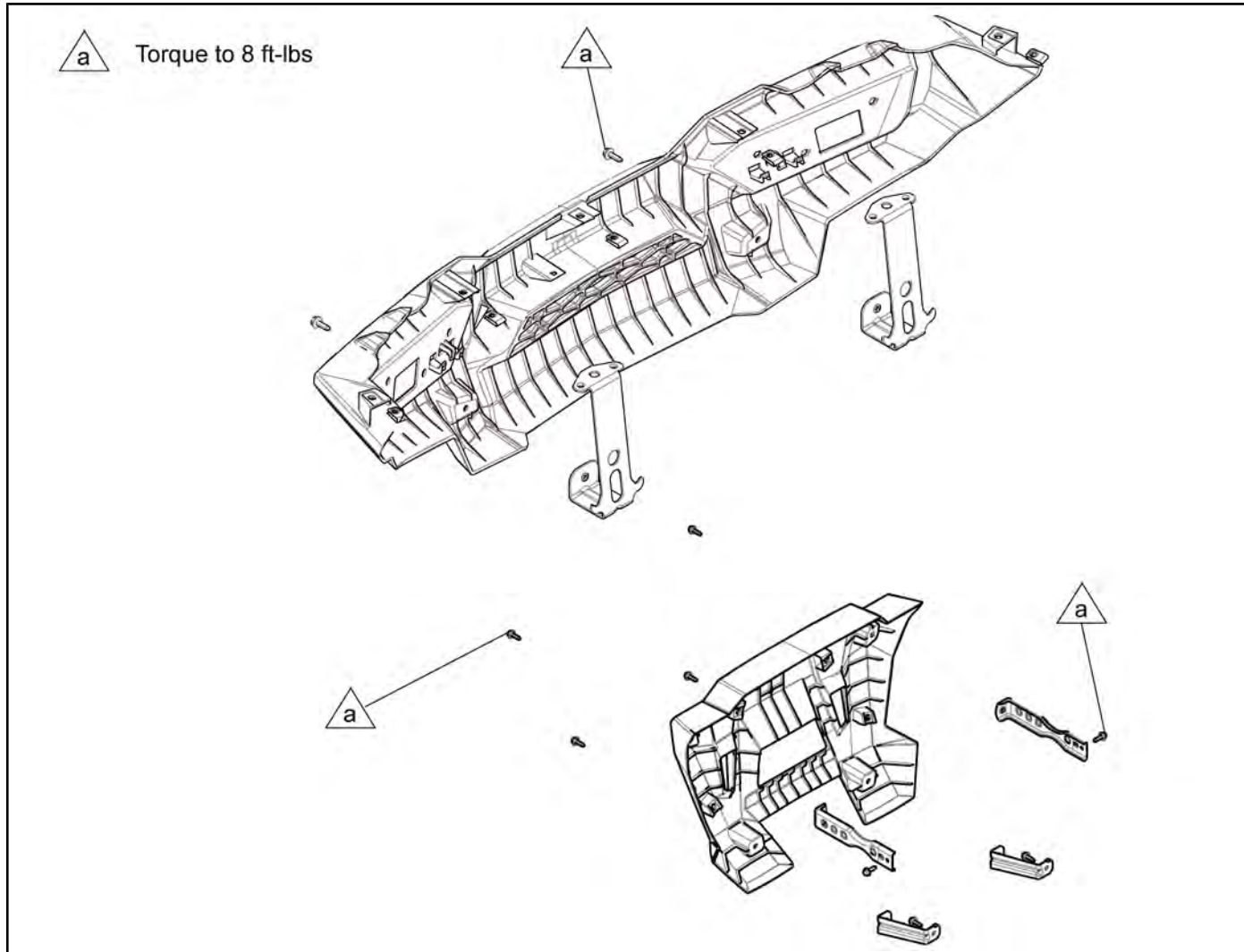

## BODY COMPONENT REMOVAL

### Seats

1. To remove any of the seats, lift upward on the latch lever (Item 1) located behind the seat bottom.

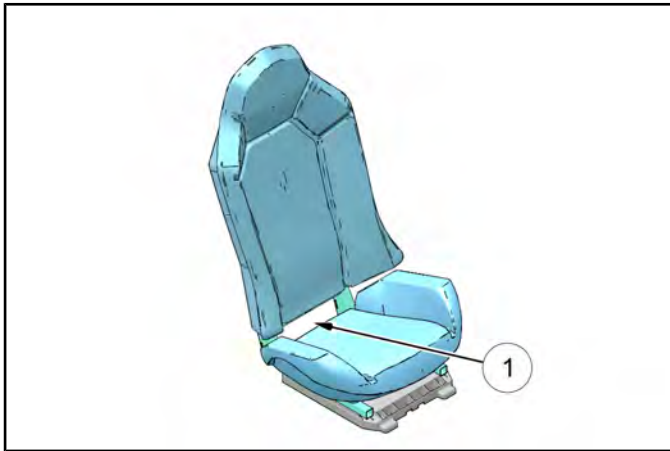

2. Lift upward and forward on the seat while lifting up on the latch lever and remove the seat from the vehicle.

### Engine Service Panel

1. Remove the seats:
  - Remove the driver and passenger seats
2. Lift the panel upward and towards the front of the vehicle to remove the panel (Item 1).

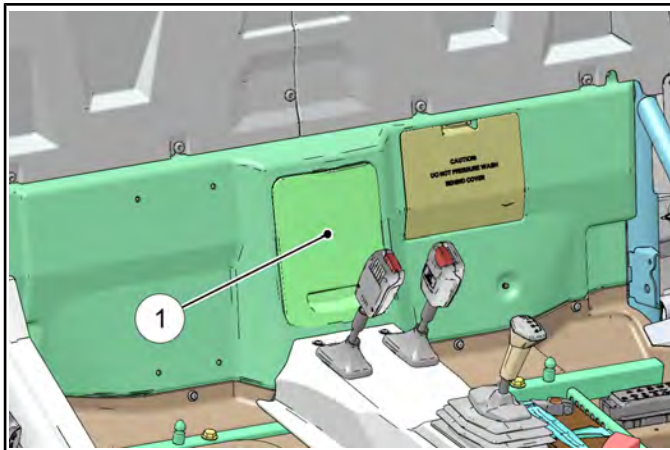

### Front Bumper XP

1. Remove the ten T-40 Torx screws retaining the front bumper.

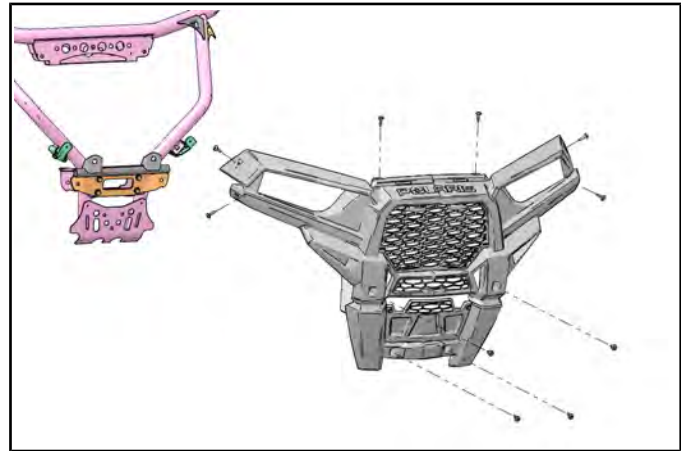

2. Disconnect the front headlight connectors.
3. Remove the ten Torx screws retaining the upper, middle and lower portion of the bumper.
4. Pull out on the front bumper to remove the bumper, headlights and radiator deflector as an assembly.
5. If replacing the front bumper, remove both headlights and the radiator deflector.

### Rear Bumper

1. Disconnect the harness connectors at the tail lights.
2. Remove the zip ties retaining the harness to the rear bumper.
3. Remove the seven (two lower and five upper) T-27 Torx screws retaining rear bumper to the cargo box.

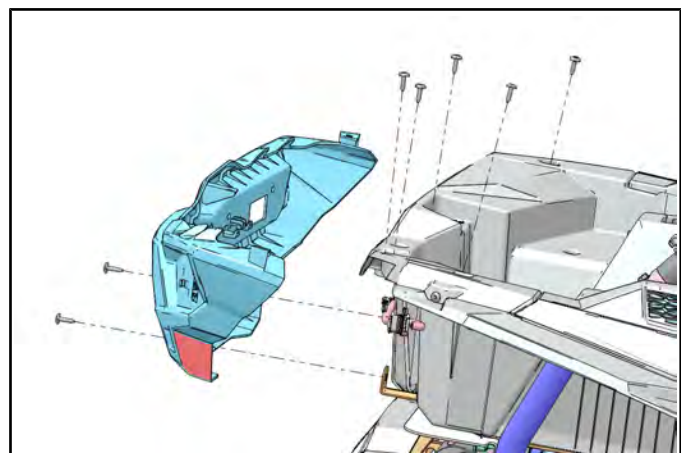

4. Remove rear bumper from vehicle.



# BODY / STEERING / SUSPENSION

## Hood and Front Body Work

### Hood Removal

1. To remove the hood, turn both 1/4 turn latches (Item 1) to disengage the rear portion of the hood.

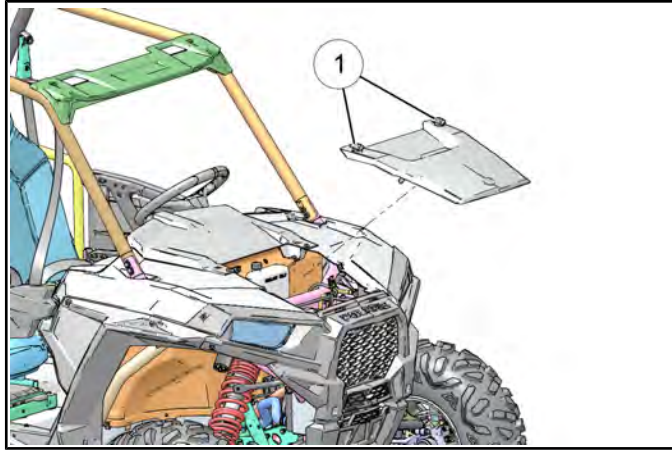

2. Lift rear of hood and slide forward to disengage the front tabs and remove the hood from the vehicle.

### Dash Removal

3. Remove the hood as previously described.
4. Remove the two T-40 Torx screws retaining the Upper Dash cover between the front fenders (Item 2).

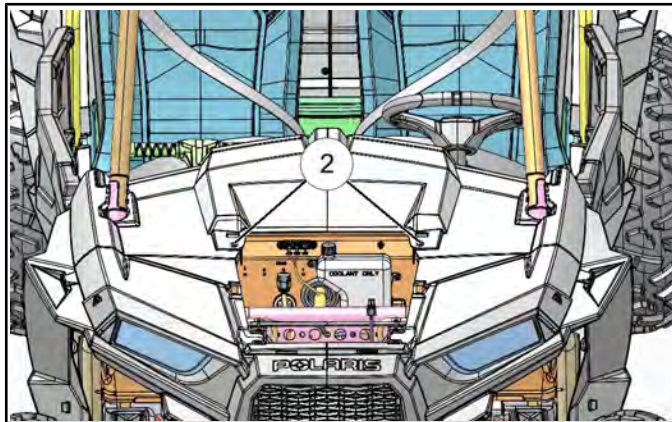

5. Disconnect the instrument cluster, AWD switch, headlight switch, and ignition switch. Note their location and wire routing. Remove the upper dash.

### Lower Dash Removal

6. Back out the blue LED light from the lower dash.
7. Remove the two T-40 Torx screws retaining the dash and the one T-40 retaining the back of the dash to the bracket..

8. Remove the dash assembly from the vehicle.

**NOTE:** The lower dash is also held by clips. Pull the dash straight out to disengage the clips..

### Front Fender Flair Removal

9. Remove the six T40 Torx screws and remove fender flairs (Item 1) from the dash assembly.

**NOTE:** Two of the screws will be longer than the others. Note this for reassembly.

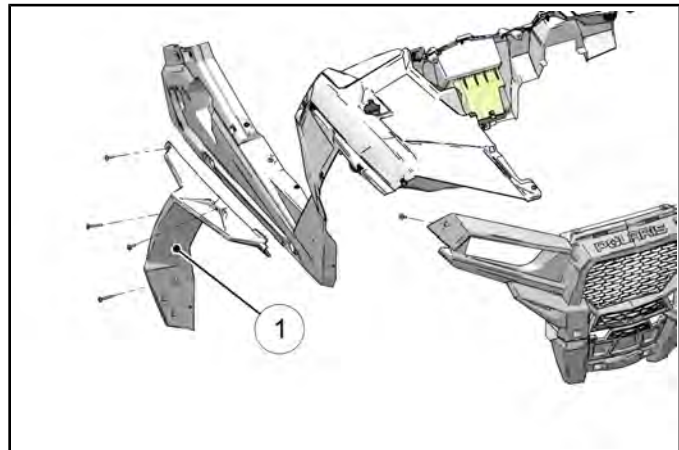

### Front Body

10. Remove the hood, upper dash and fender flairs as previously stated.
11. Remove the two T-40 Torx screw that were hidden beneath the fender flair (one on the outside of the fender and one on the inside).
12. Remove the front portion of the cab frame assembly. Refer to appropriate "CAB FRAME - Assembly / Removal" procedure for assembly torque specifications.

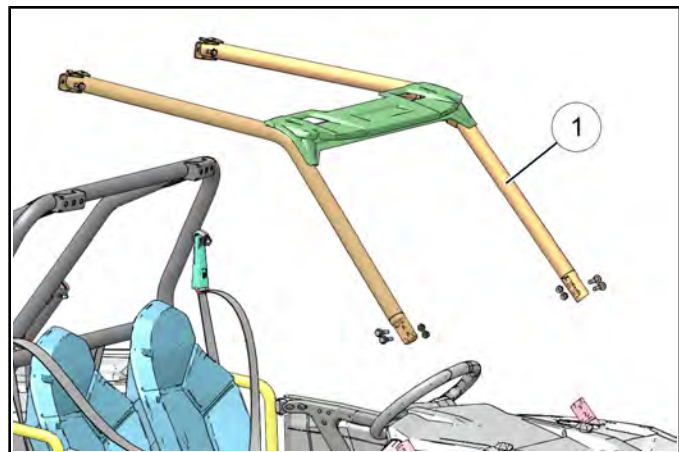

13. Remove the front fender.

## Rear Fender / Fender Flare Removal

1. Remove the four T27 Torx screws (Item 1). Remove the three plastic rivets on the lower side of the rear fender flare.

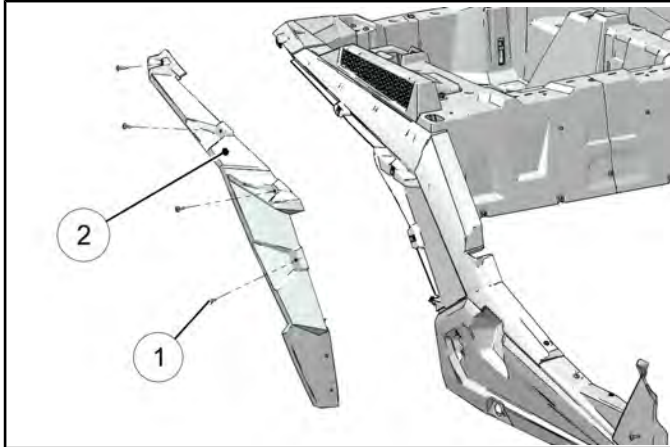

2. Remove the fender flare (Item 2) from the vehicle.
3. Remove the four plastic rivets (one of them hidden on the inside) retaining the rear fender.
4. Remove the one T-40 Torx screw on the top rear of the fender.
5. Remove it from the vehicle.

## Rear Fender Flare / Rear Fender Removal XP 4

1. Remove the three plastic rivets on the lower fender flare (Item 1). Remove the four T40 Torx screws (Item 2).

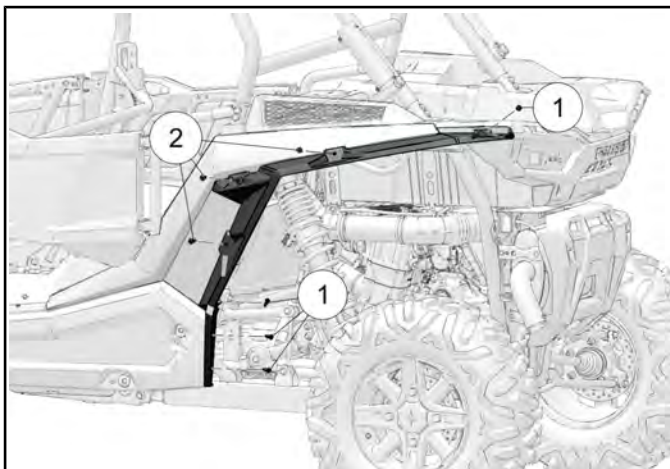

2. Remove the fender flare from the vehicle.

3. Remove air intake cover (Item 3) if removing left side fender.

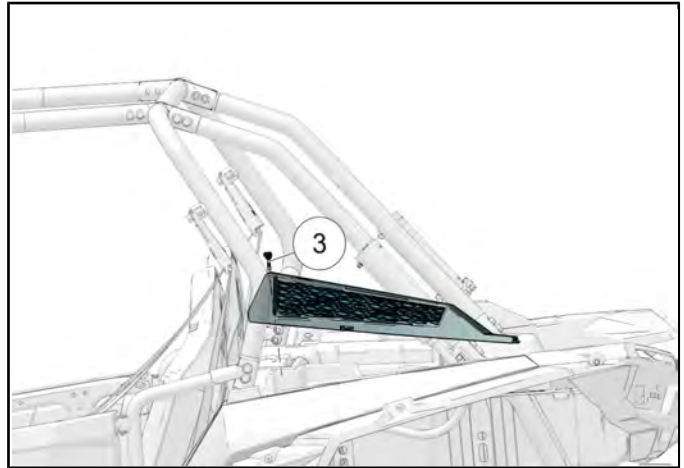

4. Remove the plastic rivets (Item 4) and one T40 Torx fastener (Item 5) retaining the rear fender.

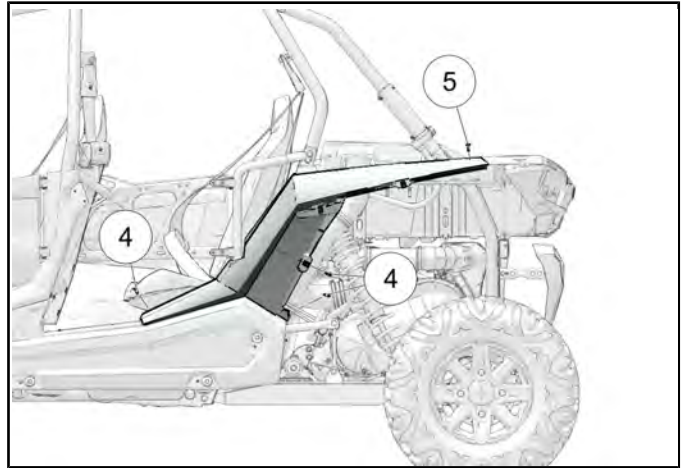

5. Remove fender from the vehicle.

## Cargo Box Assembly Removal

1. Remove both seats.
2. Remove the PVT pre-filter (driver side) and air intake pre-filter (passenger side) assembly.
3. Remove the T-25 Torx screw retaining each shock reservoir hose cover and remove the cover..
4. Loosen the shock reservoir clamps and maneuver the reservoir through the hole in the box.

**NOTE:** Do NOT let the reservoir hang by the hose. Use a wire or string to restrain the reservoir.

## BODY / STEERING / SUSPENSION

5. Remove the four bolts retaining each rear cab frame and remove it from the vehicle. Remove the bolts retaining the hip bolsters to the cab frame hoop.

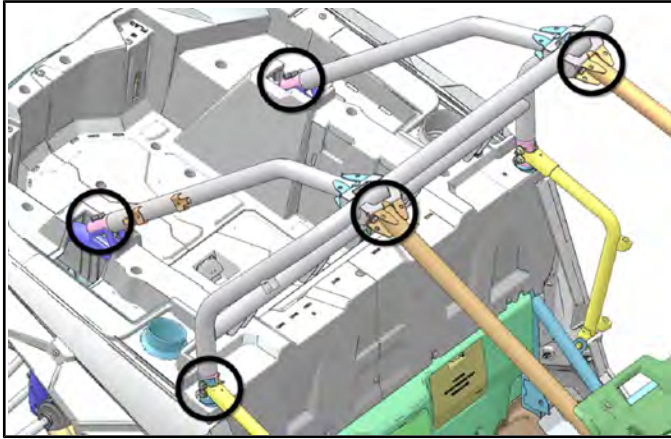

6. Remove the eight fasteners retaining the rear cab frame to the frame and to the front cab frame. Remove the rear cab frame from the vehicle.
7. Remove the engine access panel and the panel locking pin (Item 1).

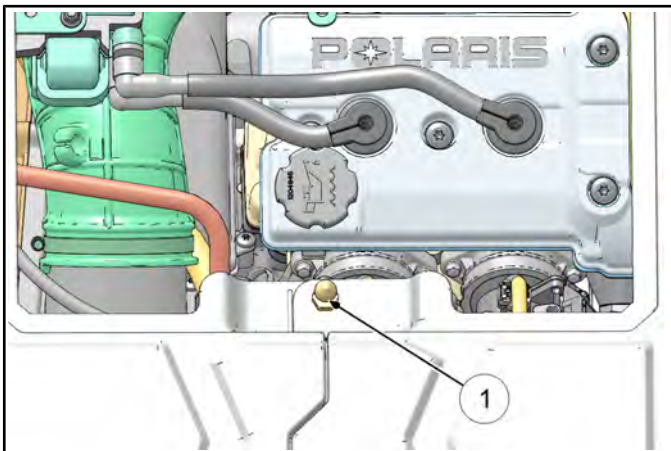

8. Remove the 17 Torx screws in the bed of the cargo box.

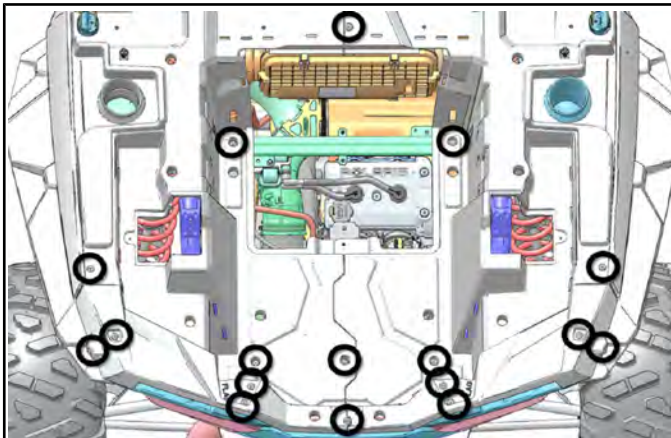

9. Remove the seven T-40 Torx screws on the cab side of cargo box.

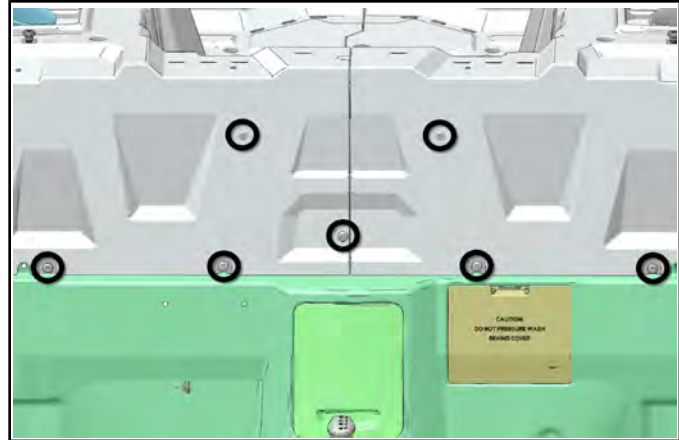

10. Remove the cargo box half from the vehicle.

### Rocker Panels, Console and Floor XP

#### Rocker Panel Removal

1. Remove the push rivets and Torx screws retaining the rocker panel and remove panel from the vehicle.

#### Console and Lower Floor Removal

2. Remove both seats and rocker panels (see "Rocker Panel Removal").
3. Remove the T27 screws (Item 1) retaining the console (Item 5) to the floor.
4. Remove shift handle knob and remove the console.

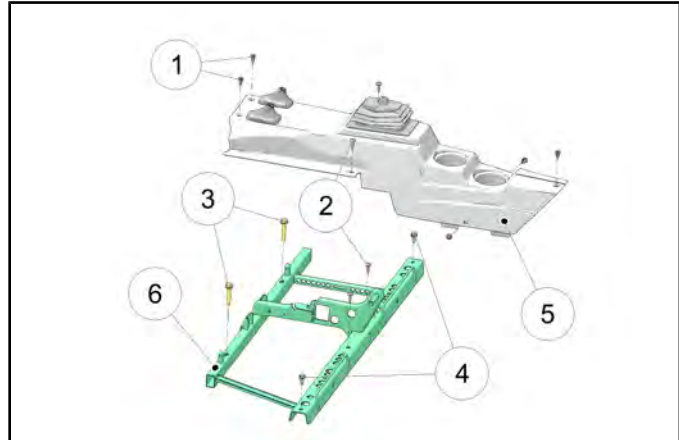

5. Remove the Torx screws retaining the upper floor (Item 8) to the lower floor (Item 9).

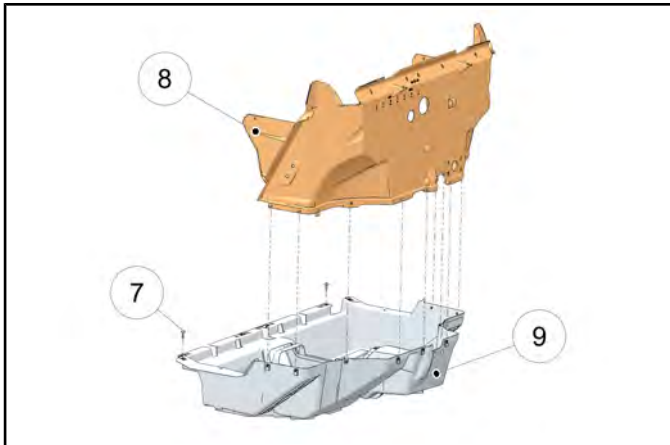

6. Remove the Torx screws (Item 7) retaining the rear portion of the floor and remove the lower floor from the vehicle.

### Rocker Panels, Rear Console and Floor XP 4

#### Rocker Panel Removal

1. Remove rear fender flare. (See "Rear Fender Flare Removal").
2. Remove rear fender. (See "Rear Fender Removal").
3. Remove the four Torx T40 rear door mounting fasteners (Item 1) and remove door.

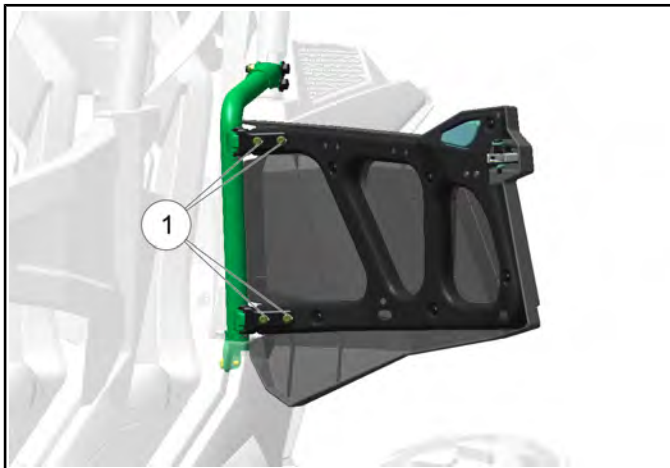

4. Remove two push rivets (Item 2). Remove two Torx T40 door striker fasteners (Item 3) and remove striker. Remove one Torx T27 fastener (Item 4) retaining the b-pillar cover and remove cover.

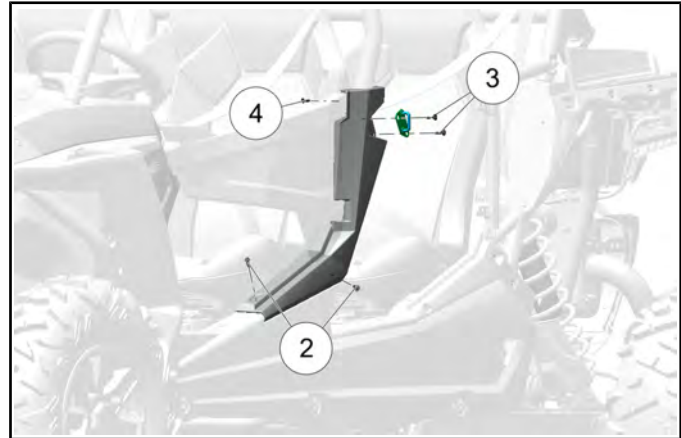

5. Remove three Torx T40 fasteners (Item 5) from top of fender flare. Remove two Torx T40 fasteners (Item 6 and 7). Note length and location of fasteners. Remove fender flare.

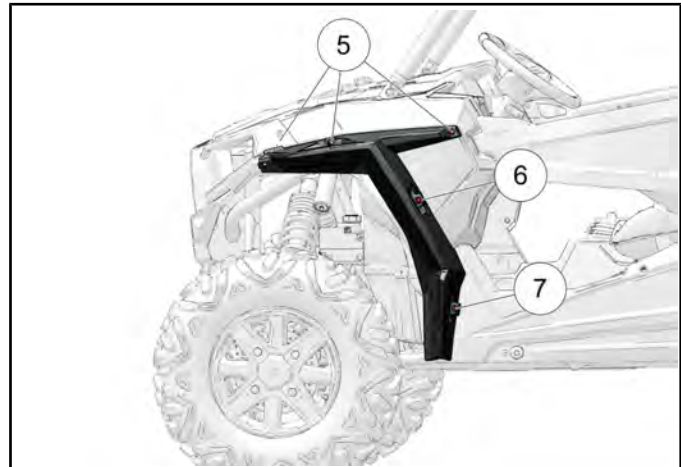

5

## BODY / STEERING / SUSPENSION

6. Remove three push rivets (Item 8) and five Torx T40 Torx fasteners (Item 9) retaining the rocker panel. Remove rocker panel from the vehicle.

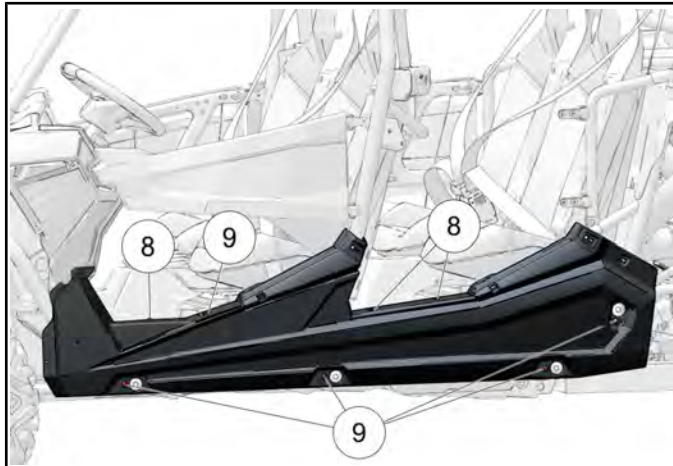

### Console and Lower Floor Removal

1. Remove seats and rocker panels (see "Rocker Panel Removal").
2. Remove four Torx T40 screws (Item 1) and five push rivets (Item 2) retaining the front console to the floor.

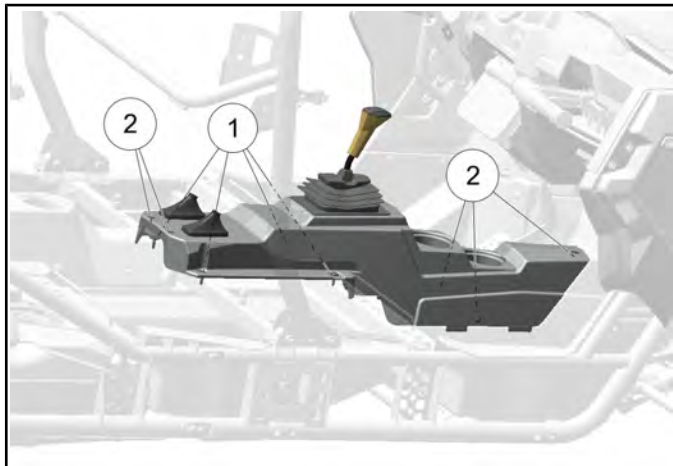

3. Remove shift handle knob and remove the front console.

4. Remove the Torx T40 screws (item 3) and push rivets (item 4) retaining the rear console to the rear floor.

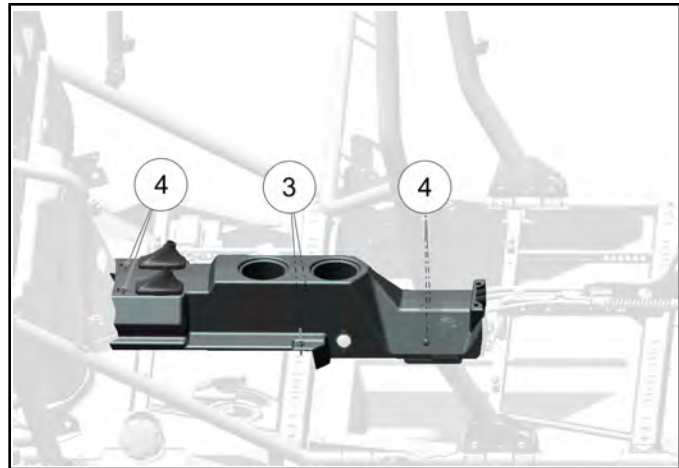

5. Remove the rear console.
6. Remove two M10x1.25x20 bolts from the rear seat frame (Item 5) and two M10x1.50x55 (Item 6) bolts from the rear seat frame assembly.

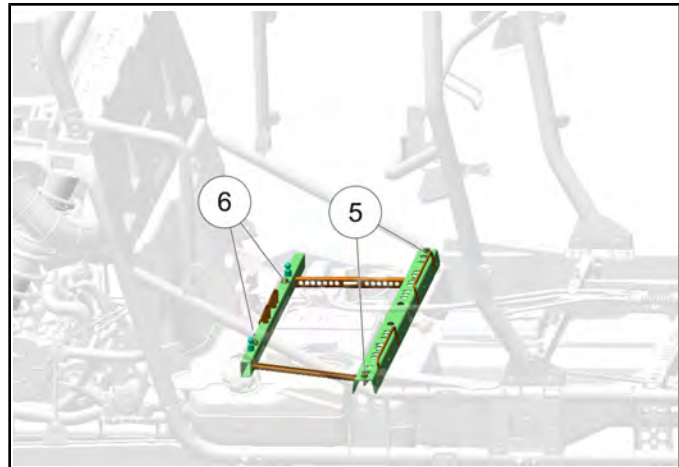

7. Remove the seat frame.
8. Disconnect negative and positive battery cables. Remove the battery.
9. Remove two fasteners retaining the fuse panel to the lower rear close off panel.
10. Remove two fasteners retaining the voltage regulator to the back of the lower rear close off panel.

## BODY / STEERING / SUSPENSION

11. Remove two Torx T40 screws (Item 7) and four push rivets (Item 8) retaining the lower rear close off panel.

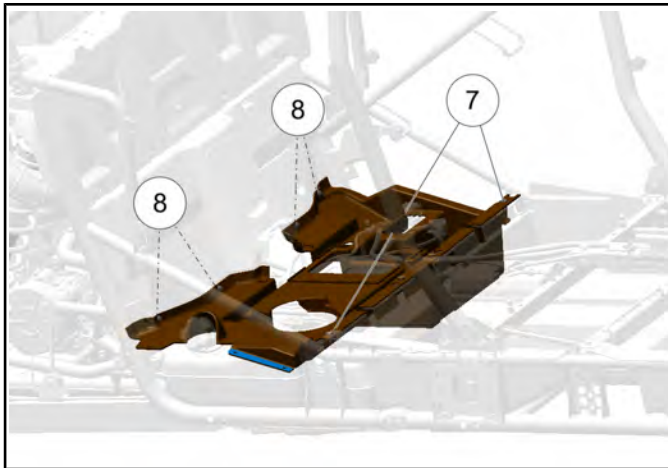

14. Remove four Torx T40 screws (Item 14) retaining the rear floor and remove the rear floor.

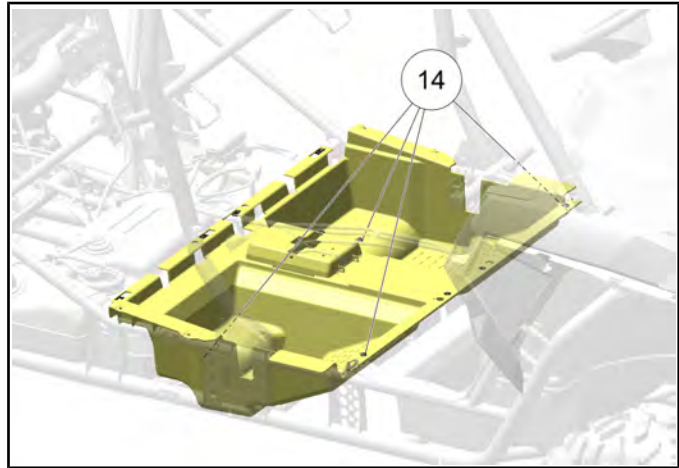

12. Remove four Torx T40 screws (Item 9) and four push rivets (Item 10) retaining the upper rear close off panel. Remove the upper close off panel.

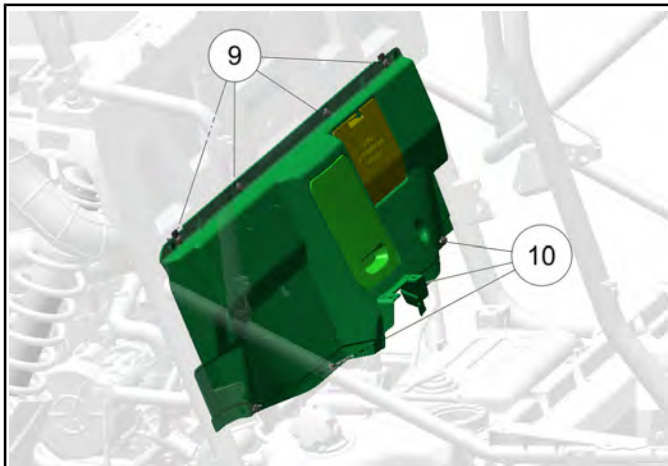

15. Remove the Torx screws (Item 15) retaining the main floor and remove the main floor from the vehicle.

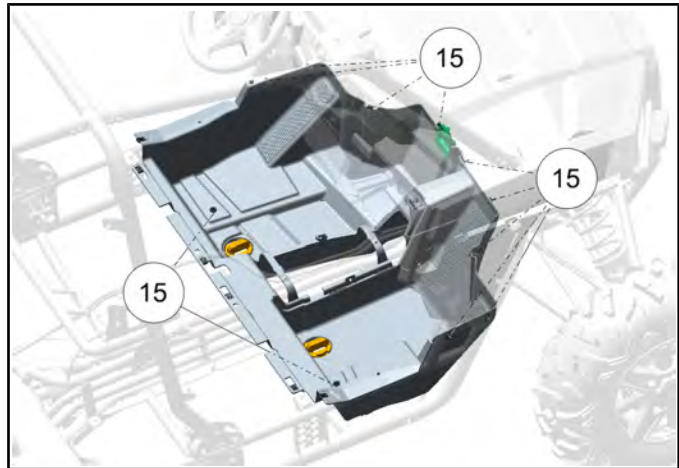

13. Disconnect the shift cable (Item 11) from the front seat base. Remove two M8x1.25x20 bolts (Item 12) and two M10x1.25x55 bolts (Item 13) from the front seat base. Remove front seat base assembly.

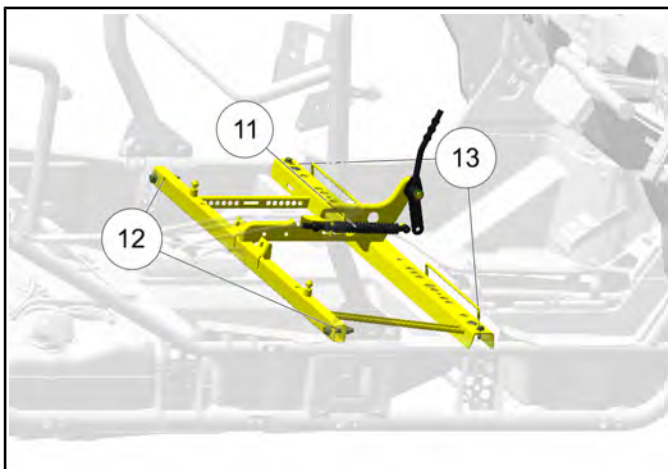

5

5.25

## BODY / STEERING / SUSPENSION

---

### DECAL REPLACEMENT

 **WARNING**

The following procedure involves the use of an open flame. Perform this procedure in a well ventilated area, away from gasoline or other flammable materials. Be sure the area to be flame treated is clean and free of gasoline or flammable residue.

 **WARNING**

Do not flame treat components that are installed on the vehicle. Remove the component from the vehicle before flame treating.

The body cab components are plastic polyethylene material. Therefore, they must be “flame treated” prior to installing a decal to ensure good adhesion. The flame treating procedure can also be used to reduce or eliminate the whitish stress marks that are sometimes left after a fender or cab is bent, flexed, or damaged.

 **CAUTION**

Do not flame treat painted plastic components. Painted plastic surfaces should only be wiped clean prior to decal adhesion.

To flame treat the decal area:

1. Pass the flame of a propane torch back and forth quickly over the area where the decal is to be applied until the surface appears slightly glossy. This should occur after just a few seconds of flame treating. Do not hold the torch too close to the surface (2-3 inches from the flame tip is recommended). Keep the torch moving to prevent damage.
2. Apply the decal on one edge first. Slowly lay down remainder of the decal while rubbing lightly over the decal surface to eliminate any air bubbles during the application.

**STEERING ASSEMBLY**

**Assembly View (Non-EPS Models)**

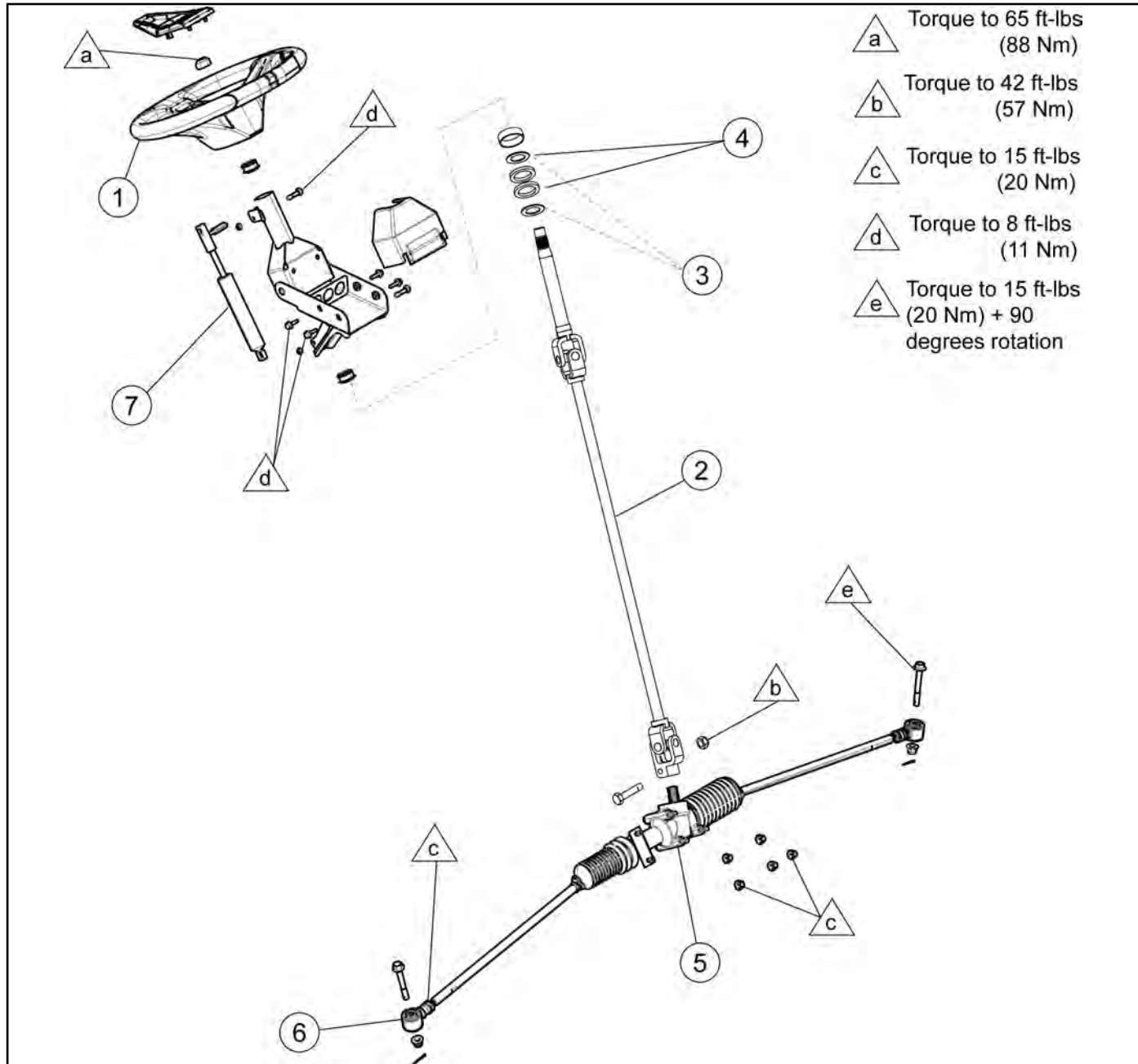



# BODY / STEERING / SUSPENSION

## Steering Wheel Removal (Non-EPS Models)



This procedure should NOT be used on EPS models. Using this procedure on an EPS model can permanently damage the EPS unit and cause a Power Steering Fault.

1. Remove the steering wheel cap.
2. Loosen the nut and back it half way off the steering shaft.
3. With a glove on your hand, place it under the steering wheel. Lift upward on the inner portion of the steering wheel while using a hammer to strike the steering shaft nut.

**NOTE: If the steering wheel will not pop loose, proceed to "Steering Shaft Removal".**

4. Once the steering wheel pops loose, completely remove the nut and lift the steering wheel off the shaft.

## Steering Shaft Removal (Non-EPS Models)

1. Remove the pinch bolt (Item 1) retaining the lower portion of the steering shaft (Item 2) to the steering gear box assembly (Item 3).

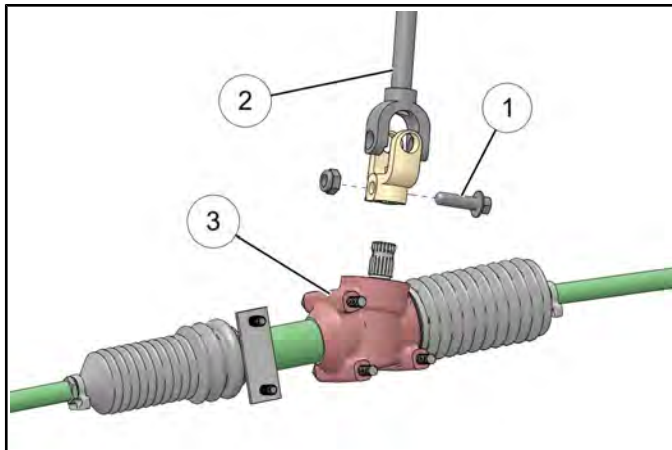

2. Remove the fastener retaining the upper portion of the steering wheel tilt shock to the pivot tube.
3. Remove the two fasteners that retain the pivot tube.
4. Remove the steering shaft, pivot tube and steering wheel from the vehicle as an assembly.
5. Refer to steps 11-13 of the "Steering Shaft Bearing Replacement" procedure for installation.

## Steering Shaft Bearing Replacement

**NOTE: Replacement pivot tube assembly comes with new upper and lower bearings installed. Use this procedure if replacing just the bearings only.**

1. Perform the "Steering Shaft Removal" procedure.
2. Remove the steering wheel cap and retaining nut.
3. Press steering shaft out of the steering wheel and pivot tube.
4. Note the order and location of the washers and spacers between the steering wheel and pivot tube.
5. Drive the bearings out of the pivot tube using a drift punch.
6. Inspect the pivot tube bearing surfaces for signs of excessive wear or damage.
7. Apply Loctite® 271™ (Red) to the outer circumference of the new lower bearing race. Slide the new lower bearing onto the steering shaft and install the steering shaft through the pivot tube.

**NOTE: Use care not to allow any of the Loctite® to get in the bearing.**

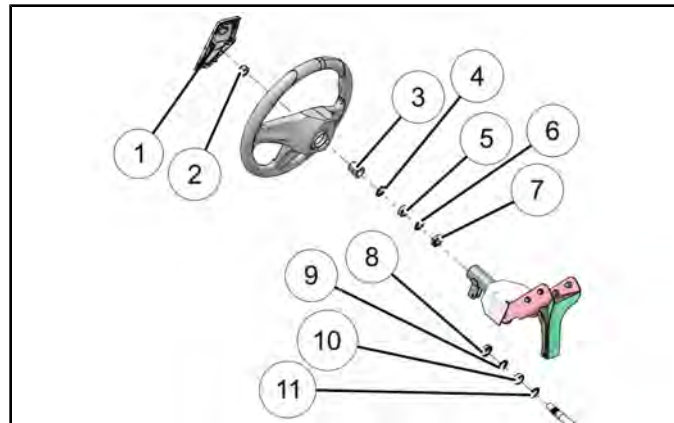

1. Cap	7. Bearing
2. Nut	8. Bearing
3. Steering Hub Insert	9. Bushing
4. Bushing	10. Bushing
5. Bushing	11. Bushing
6. Bushing	

**Be sure the lower washers and spacers are still on the steering shaft.**

## BODY / STEERING / SUSPENSION

8. Apply Loctite® 271™ (Red) to the outer circumference of the new upper bearing race. Slide the new upper bearing onto the steering shaft and press it into the pivot tube by hand.

**NOTE: Use care not to allow any of the Loctite® to get in the bearing.**

**Bearings will be seated in the pivot housing upon tightening the steering wheel nut in step 14.**

9. Reinstall the upper washers and spacers in the order in which they were removed.
10. Install the steering wheel and hand tighten the nut. Apply Loctite® 271™.
11. Reinstall the steering shaft assembly in the vehicle. Install the lower portion of the steering shaft onto the steering gear box assembly (see Figure 5-16). Torque the lower pinch bolt to specification.



Lower Steering Pinch Bolt:  
**30 ft-lbs (41 Nm)**

12. Install the two fasteners that retain the pivot tube (see Figure 5-17). Torque fasteners to specification.



Pivot Tube Bolts:  
**23 ft-lbs (31 Nm)**

13. Install the fastener retaining the upper portion of the steering wheel tilt shock to the pivot tube (see Figure 5-17). Torque fastener to specification.



Tilt Shock Bolt:  
**7 ft-lbs (10 Nm)**

14. Be sure the front wheels are facing straight forward. Remove the steering wheel and align as needed. Torque the steering wheel nut to specification. Apply Loctite® 271™



Steering Wheel Nut:  
**65 ft-lbs (88 Nm)**

15. Wipe the pivot tube clean of any excess Loctite®.
16. Install steering wheel cap and field test steering operation.

# BODY / STEERING / SUSPENSION

## ELECTRONIC POWER STEERING ASSEMBLY

### Assembly View (EPS Models)

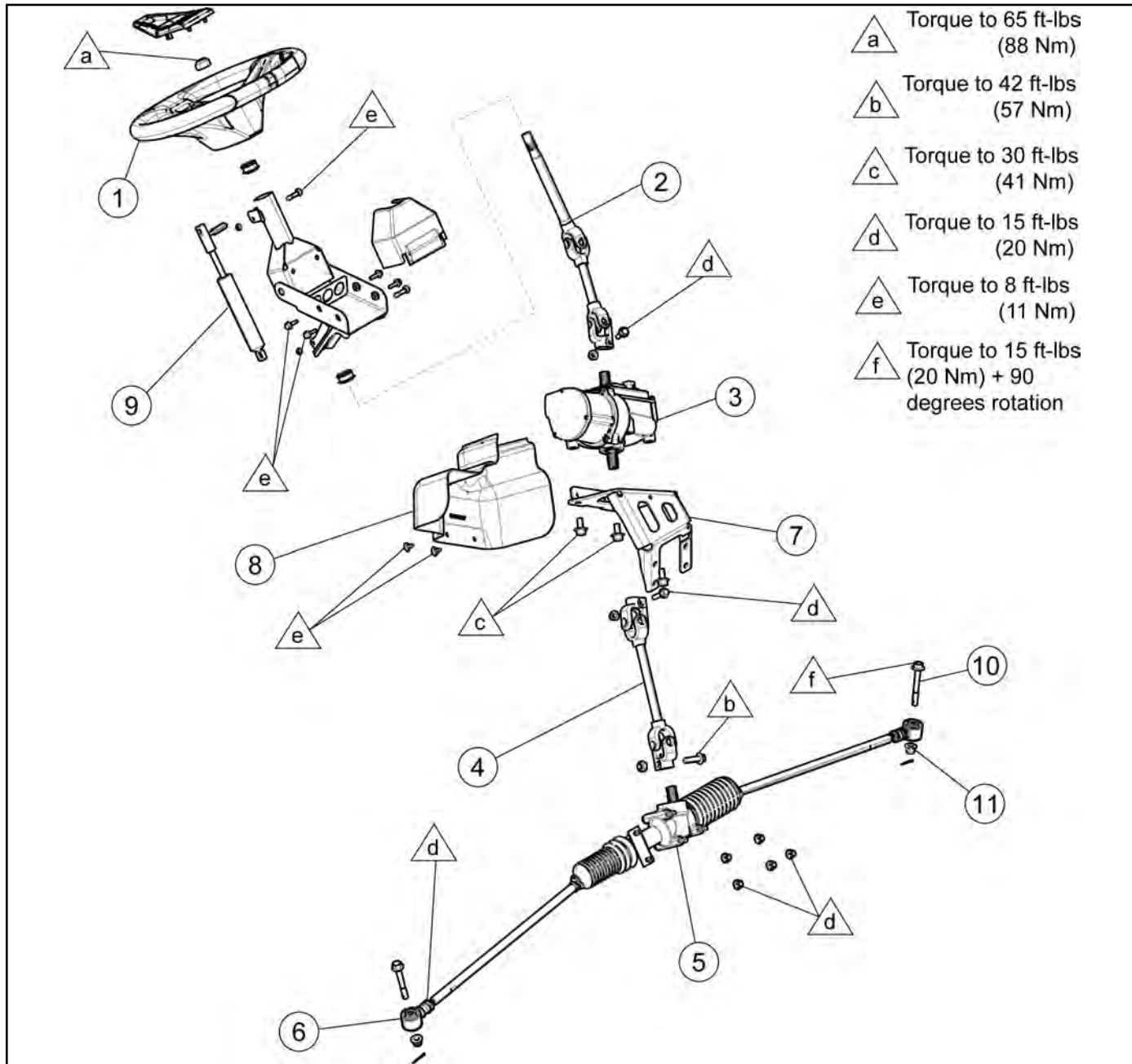

1. Steering Wheel	5. Steering Box	9. Tilt Steering Shock
2. Upper Steering Shaft	6. Tie Rod End	10. Tie Rod End Bolt (Do not reuse)
3. EPS Module	7. EPS Mount Bracket	11. Nut, Nylok (Do not reuse)
4. Lower Steering Shaft	8. EPS Cover	

## Upper Steering Shaft Removal (EPS Models)

1. Remove the two Torx fasteners (Item 1) retaining the black plastic cover and remove the cover from the vehicle.

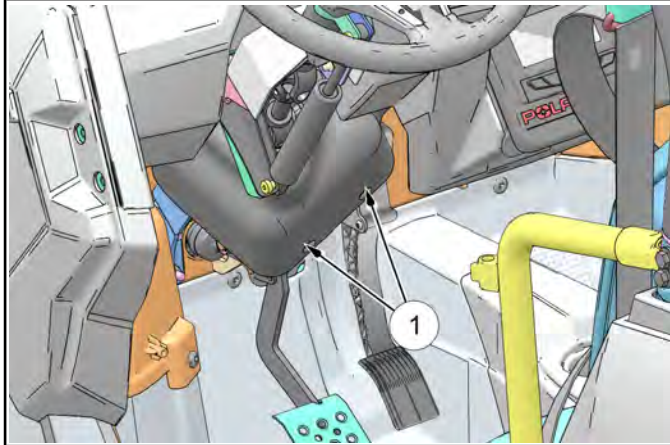

2. Remove the pinch bolt retaining the upper steering shaft to the power steering unit.

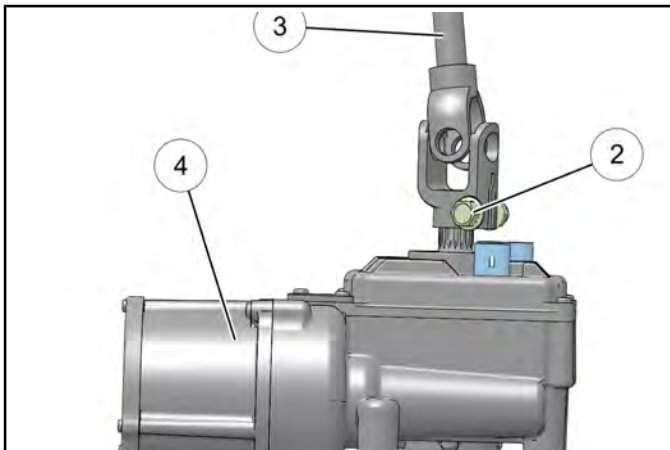

3. Lift the steering wheel up and remove the four fasteners (Item 5) that retain the pivot tube.

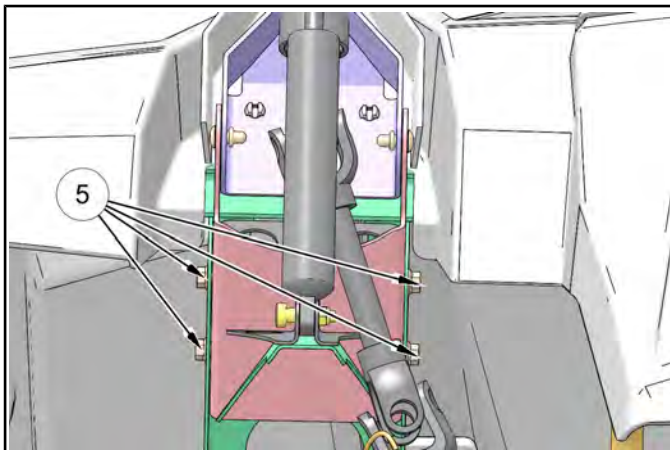

4. Remove the steering shaft, pivot tube and steering wheel from the vehicle as an assembly.

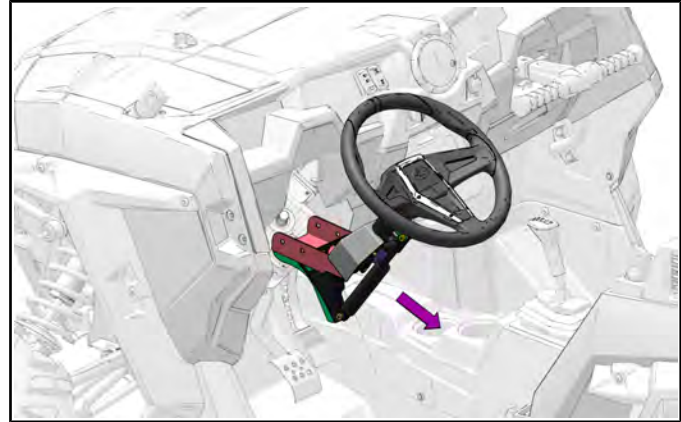

5. If replacing the upper steering shaft or steering wheel, refer to Steering Wheel Removal (EPS Models), page 5.31.

5

## Steering Wheel Removal (EPS Models)

1. Remove the upper steering shaft, pivot tube and steering wheel as an assembly *before* attempting to remove the steering wheel. Refer to Upper Steering Shaft Removal (EPS Models), page 5.31.

### CAUTION

Striking the steering wheel or steering shaft while installed in the vehicle can permanently damage the EPS unit and cause a Power Steering Fault.

2. Remove the steering wheel cap.



3. Loosen the nut and back it half way off the steering shaft.
4. Place the assembly in a vise.

5.31

## BODY / STEERING / SUSPENSION

- Using a large bronze drift and hammer, strike the steering shaft nut to pop the steering wheel off the shaft taper.

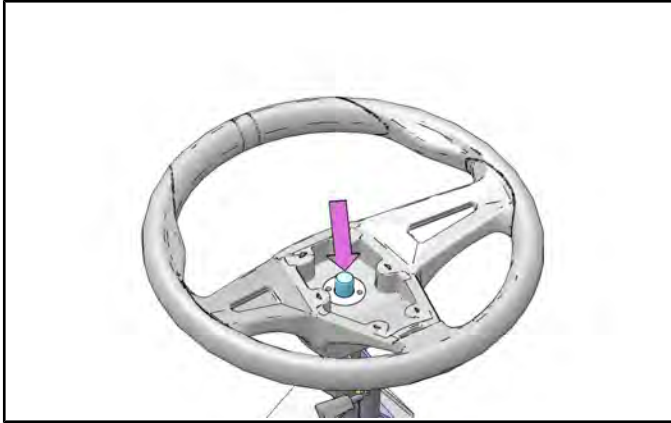

- Remove the pinch bolt retaining the lower steering shaft to the power steering unit.

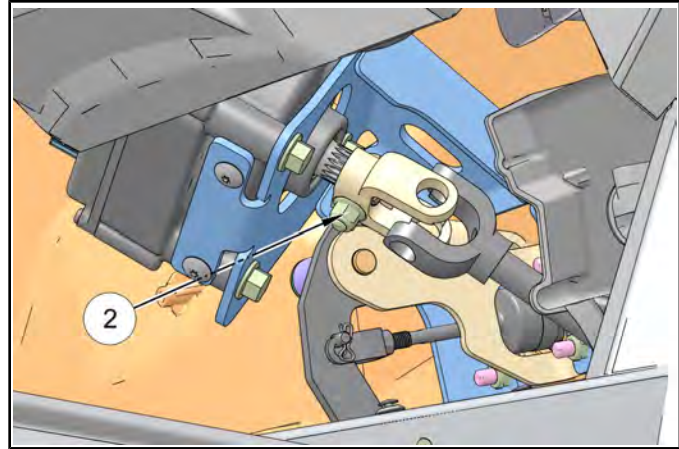

- Once the steering wheel pops loose, completely remove the nut and lift the steering wheel off the shaft.

- While supporting the power steering unit, remove the four nuts (Item 3) from the mount bracket.

### Power Steering Unit Removal

- Remove the upper steering shaft, pivot tube and steering wheel from the vehicle as an assembly. Refer to Upper Steering Shaft Removal (EPS Models), page 5.31.

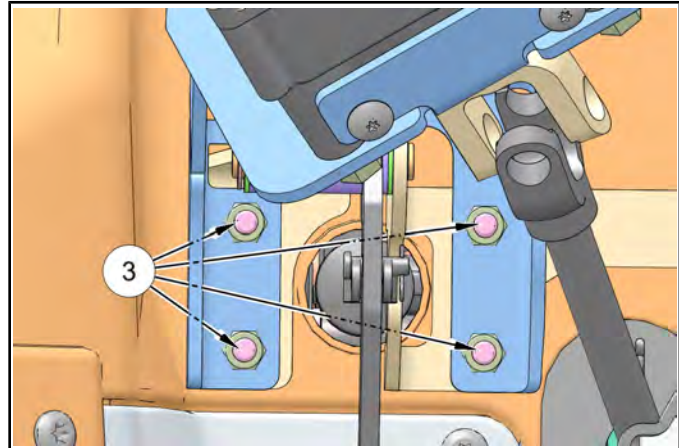

#### CAUTION

Striking the steering wheel or steering shaft while installed in the vehicle can permanently damage the EPS unit and cause a power steering fault.

- Disconnect the two electrical harnesses from the power steering unit.

- Carefully remove the power steering unit and mount bracket from the vehicle as an assembly.

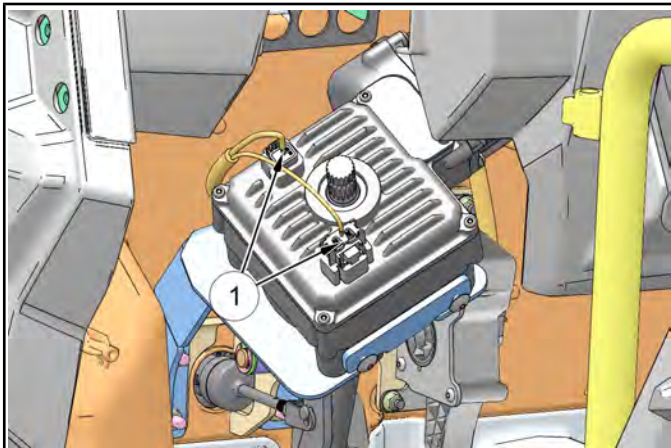

6. If replacing the power steering unit, remove the three bolts (Item 4) that retain the power steering unit to the mount bracket.

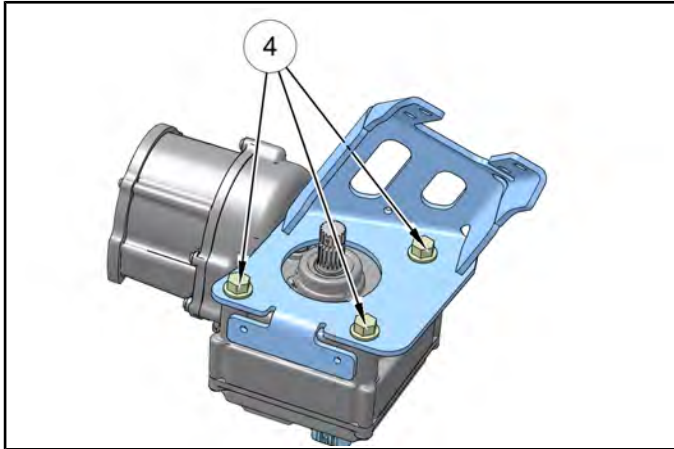

### WARNING

Electronic Power Steering (EPS) units are programmed to be vehicle specific and are not interchangeable between product lines.

### Lower Steering Shaft Removal (EPS Models)

1. Use the steering wheel to position the front wheels so they point straight ahead.
2. Locate the lower steering shaft through the left front wheel well. Mark the lower steering shaft, gear box stub shaft and gear box to aid installation.

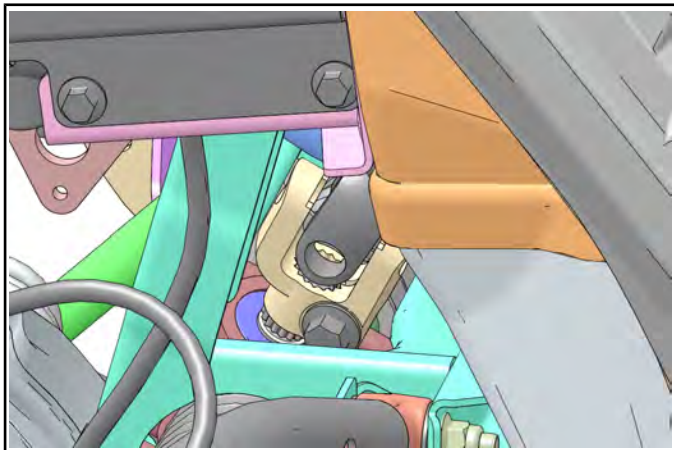

3. Remove the power steering unit (see "Power Steering Unit Removal" procedure).

4. Remove the pinch bolt (Item 1) retaining the lower steering shaft (Item 2) to the steering gear box assembly (Item 3).

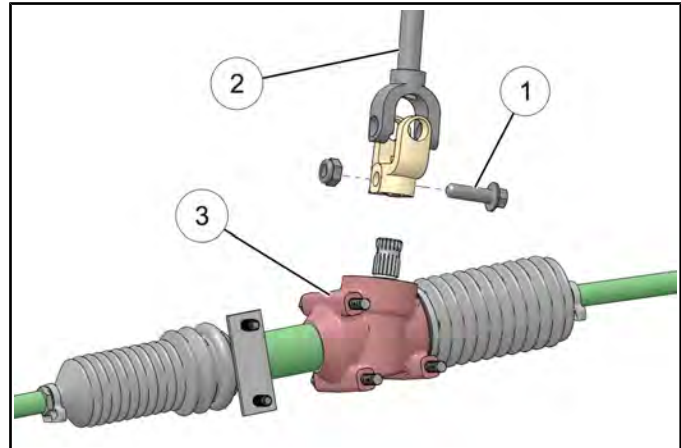

5. Lift up on the shaft and remove it through the floor panel.

5

### Lower Steering Shaft Installation (EPS Models)

1. Install the lower steering shaft onto the gear box and align the marks made during step 2 of the "Lower Steering Shaft Removal (EPS Models)" procedure.
2. Install the pinch bolt that retains the lower steering shaft to the steering rack assembly and torque to specification.



Lower Steering Shaft Pinch Bolt:  
**42 ft-lb (57 Nm)**

3. Install the power steering unit and reassemble the vehicle (see "Power Steering Unit Installation" procedure).

## BODY / STEERING / SUSPENSION

### Power Steering Unit Installation

1. If the power steering unit (Item 1) was removed from the mount bracket (Item 2), reinstall it prior to vehicle installation. Torque the mounting bolts (Item 3) to 20–24 ft. lbs. (27–33 Nm)

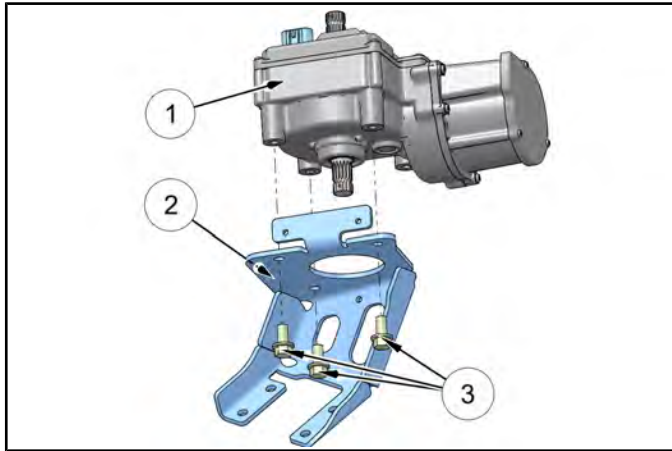

2. Install the power steering unit into the vehicle and align the skip-tooth spline on the power steering shaft with the opening in the lower steering shaft.

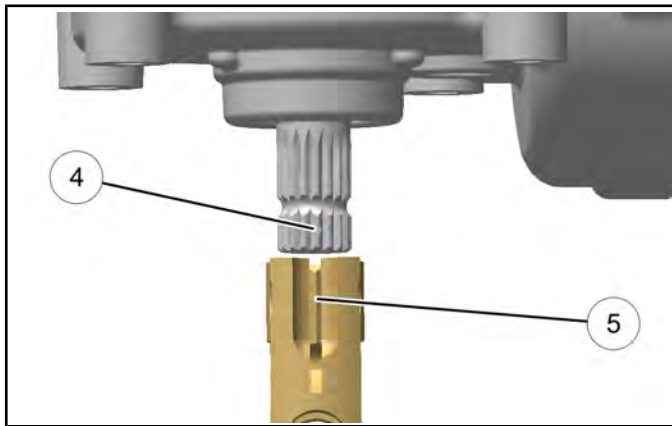

3. Place the power steering mount bracket over the top of the brake pedal mount studs and finger tighten the four nuts.
4. Position the lower steering shaft on the power steering unit stub shaft and install the pinch bolt. Torque to specification.



Lower Steering Shaft to EPS Unit Pinch Bolt:  
**15 ft-lbs (20 Nm)**

5. Torque the four mount bracket nuts (Item 6) to specification.

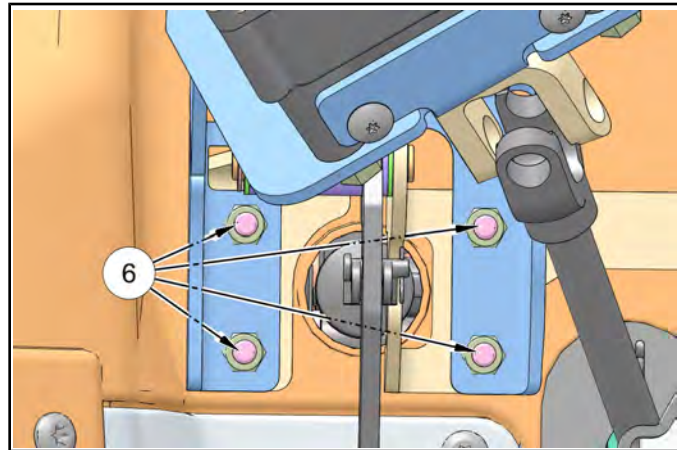

Power Steering Unit Mount Bracket Nuts:  
**16 ft-lb (22 Nm)**

6. Proceed to Upper Steering Shaft Installation (EPS Models), page 5.34 to complete the installation procedure.

### Upper Steering Shaft Installation (EPS Models)

**NOTE:** If steering wheel was removed, follow this procedure to ensure the upper steering shaft is properly positioned on the power steering stub shaft.



Striking the steering wheel or steering shaft can permanently damage the EPS unit and cause a Power Steering Fault.

## BODY / STEERING / SUSPENSION

**NOTE:** Be sure upper steering shaft hardware is positioned correctly (see “Exploded View”).

1. Install the upper steering shaft and align the skip-tooth spline (Item 1) on the power steering stub shaft with the opening (Item 2) in the upper steering shaft.

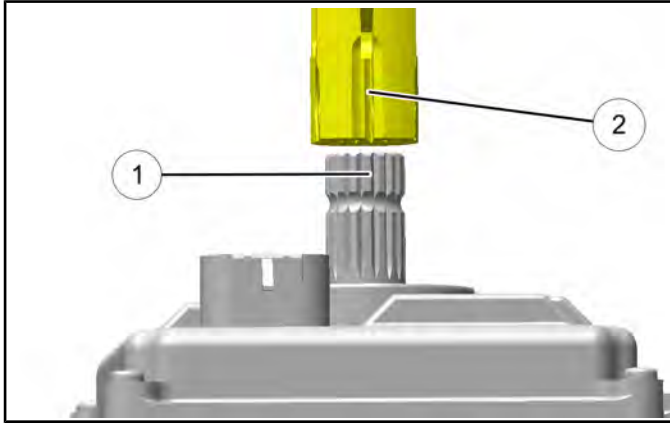

2. Install the pivot tube and torque fasteners to specification.



Pivot Tube Fasteners:  
**8 ft-lb (11 Nm)**

3. Install the tilt shock and torque fastener to specification.



Tilt Shock Fastener:  
**7 ft-lb (10 Nm)**

4. Be sure the front wheels are pointing straight ahead and install the steering wheel and retaining nut. Torque the nut to specification and reinstall the plastic wheel cover.



Steering Wheel Nut:  
**65 ft-lbs (88 Nm)**

5. Install a new upper steering shaft pinch bolt and nut. Torque pinch bolt to specification.



Upper Steering Shaft Pinch Bolt:  
**15 ft-lbs (20 Nm)**

6. Reconnect both electrical harnesses onto the power steering unit. Be sure the connectors snap into place.
7. Reinstall the black plastic cover over the power steering unit and install the two Torx-head fasteners.
8. Turn the key switch on and test EPS operation.



# BODY / STEERING / SUSPENSION

## FRONT A-ARMS

### Removal / Replacement

The following procedure details upper and lower A-arm removal and replacement on one side of the vehicle.

#### Upper A-Arm

1. Elevate and safely support the front of the vehicle and remove the front wheel.
2. Remove lower shock fastener (Item 1) from upper A-arm.

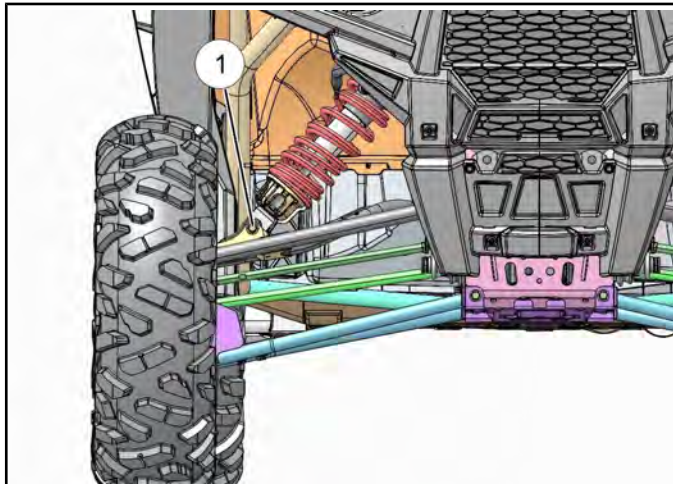

3. Remove upper ball joint pinch bolt (Item 2) from bearing carrier.

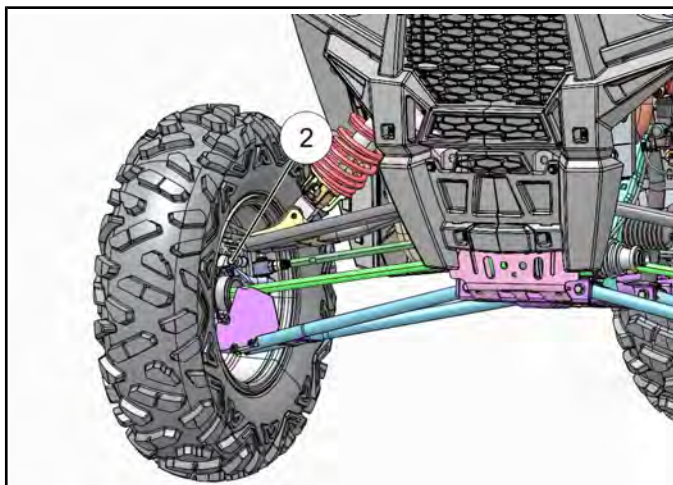

4. Using a soft face hammer, tap on bearing carrier to loosen the upper A-arm ball joint end while lifting upward on the upper A-arm. Completely remove the ball joint end from the bearing carrier.
5. Remove the front bumper to allow A-arm bolt removal.

6. Loosen and remove the upper A-arm front through-bolt fastener (Item 3) and rear through-bolt fastener (Item 4). Remove the upper A-arm from the vehicle.

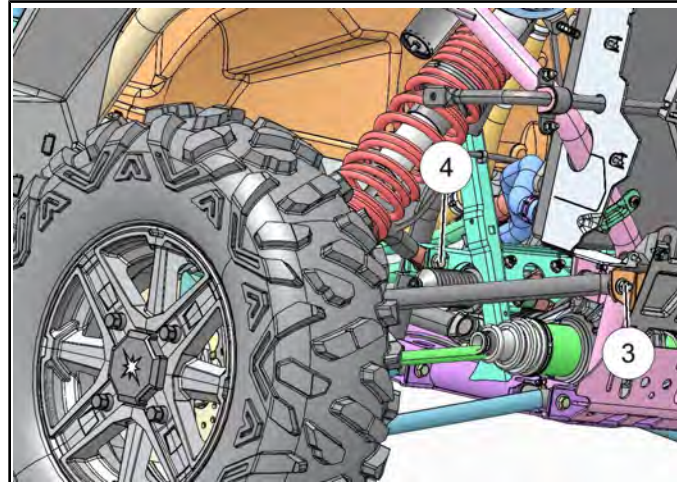

7. Examine A-arm bushings and pivot tube. Replace if worn. Discard hardware.

### WARNING

The locking agent on the existing bolts was destroyed during removal. DO NOT reuse old hardware. Serious injury or death could result if fasteners come loose during operation.

8. If not replacing the A-arm, thoroughly clean the A-arm and pivot tube.
9. Install new ball joint into A-arm. Refer to "Ball Joint Replacement" section.
10. Insert new A-arm bushings and pivot tube into new A-arm.
11. Install new upper A-arm assembly onto vehicle frame. Torque new bolt to specification.



Front Upper A-arm Bolts:  
**42 ft-lb (57 Nm)**

12. Insert upper A-arm ball joint end into the bearing carrier. Install upper ball joint pinch bolt into the bearing carrier and torque bolt to specification.

 = T
Front Ball Joint Pinch Bolts: <b>42 ft-lbs (57 Nm)</b>

13. Attach shock to A-arm with fastener. Torque lower shock bolt to specification.

 = T
Front Shock Mounting Bolts: <b>44 ft-lb (60 Nm)</b>

### Lower A-Arm

14. Remove lower ball joint pinch bolt (Item 5) from bearing carrier.

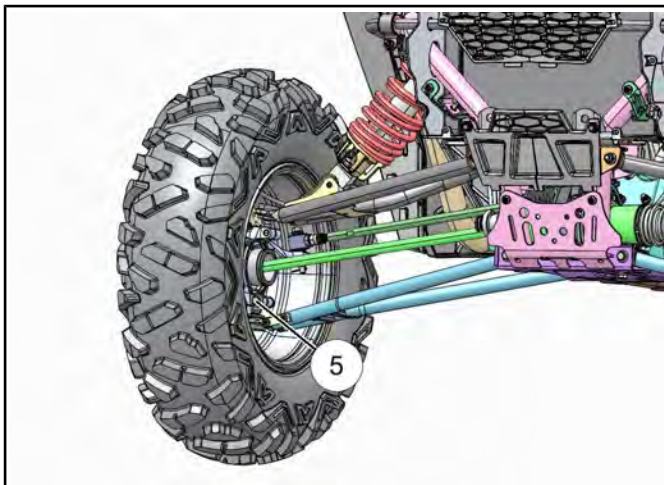

15. Using a soft face hammer, tap on bearing carrier to loosen the lower A-arm ball joint end while pushing downward on the lower A-arm. Completely remove the ball joint end from the bearing carrier.

16. Loosen and remove the lower A-arm front through-bolt fastener (Item 6) and rear through-bolt fastener (Item 7). Remove the lower A-arm from the vehicle.

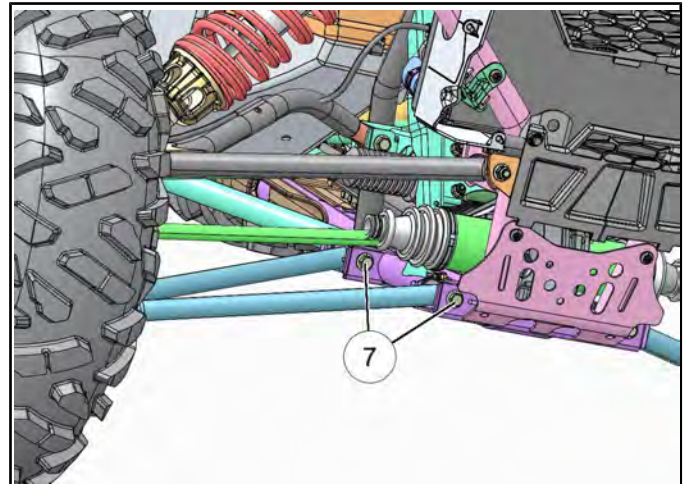

17. Examine A-arm bushings and pivot tube. Replace if worn. Discard hardware.
18. If not replacing the A-arm, thoroughly clean the A-arm and pivot tube.
19. Install new ball joint into A-arm. Refer to "Ball Joint Replacement" section.
20. Insert new A-arm bushings and pivot tube into new A-arm. A light press force may be needed.
21. Install new lower A-arm assembly onto vehicle frame. Torque new bolt to specification.
22. Insert lower A-arm ball joint end into the bearing carrier. Install lower ball joint pinch bolt into the bearing carrier and torque bolt to specification.

 <b>WARNING</b>
Upon A-arm installation, test vehicle at low speeds before putting into service.

 = T
Lower A-arm Bolts: <b>44 ft-lb (60 Nm)</b>
Front Ball Joint Pinch Bolts: <b>42 ft-lbs (57 Nm)</b>

5



## BALL JOINT SERVICE

### Service Preparation

**NOTE:** Do not reuse a ball joint if it has been removed. If removed, it must be replaced. Use this removal procedure only when replacing the ball joint.

1. Properly lift and support the vehicle by the frame.
2. Remove the appropriate front wheel.
3. **To service the upper ball joint:**
4. Remove and discard the two front brake caliper mounting bolts and remove the caliper from the brake disc (see "Brakes" chapter).
5. Remove and discard the upper ball joint pinch bolt.
6. If necessary, remove the lower front shock fastener from the A-arm.
7. Remove the upper A-Arm to frame mounting bolts and remove the A-arm from the chassis.
8. **To service the lower ball joint:**
9. Remove and discard the lower ball joint pinch bolt.
10. Remove both A-arm to frame mounting bolts and remove the A-arm from the chassis.

### Ball Joint Removal

1. Remove the retaining ring (Item 7) from the ball joint (Item 8).

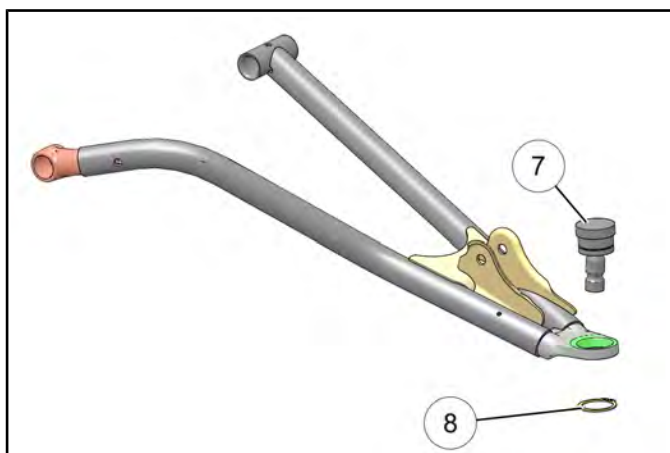

2. Place a proper sized driver on the ball joint and place the A-arm in a press.
3. Carefully press the ball joint out of the A-arm and discard the ball joint.

### Ball Joint Installation

1. By hand, install the NEW ball joint into the A-arm.
2. Using a press, carefully drive in the new ball joint into the A-arm.
3. After the new ball joint (Item 7) is fully installed into the A-arm (Item 5), install a new retaining ring (Item 6).

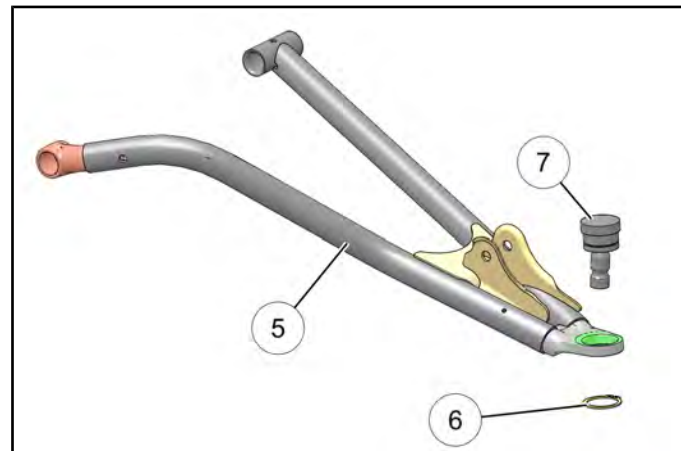

4. Repeat the ball joint service procedure for any additional A-arm ball joint replacements.
5. Insert upper / lower A-arm ball joint end into the bearing carrier. Install new pinch bolts and nuts. Torque to specification.
6. If needed, install new brake caliper mounting bolts and torque to specification.

### CAUTION

New bolts have a pre-applied locking agent which is destroyed upon removal. Always use new brake caliper mounting bolts upon assembly.

7. Install wheel and four wheel nuts. Torque wheel nuts to specification.



Front Ball Joint Pinch Bolts:  
**42 ft-lbs (57 Nm)**

Front Shock Mounting Bolts:  
**44 ft-lb (60 Nm)**

Front Caliper Mounting Bolts:  
**40 ft-lbs (54 Nm)**

Wheel Nuts (Alum):  
**120 ft-lbs (163 Nm)**

# BODY / STEERING / SUSPENSION

## REAR RADIUS RODS

### Removal / Installation

The following procedure details upper and lower radius rod removal and replacement on one side of the vehicle. Repeat the following steps to remove the A-arm from the opposite side.

1. Raise and support vehicle by main frame.

#### CAUTION

Serious injury may result if machine tips or falls. Be sure machine is secure before beginning this service procedure.

2. Remove the rear wheel nuts and rear wheel.
3. Identify / mark radius rods "upper" and "lower".
4. Remove the nut, bolt and washer (Item 1 & 2) attaching the upper and lower radius rod to the bearing carrier. Discard the nuts.

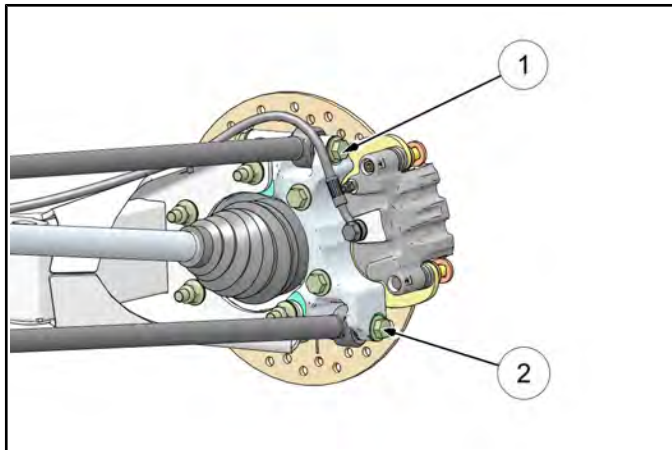

5. Remove bolts (Item 3 & 4) attaching radius rods to the vehicle frame. Discard the nuts.

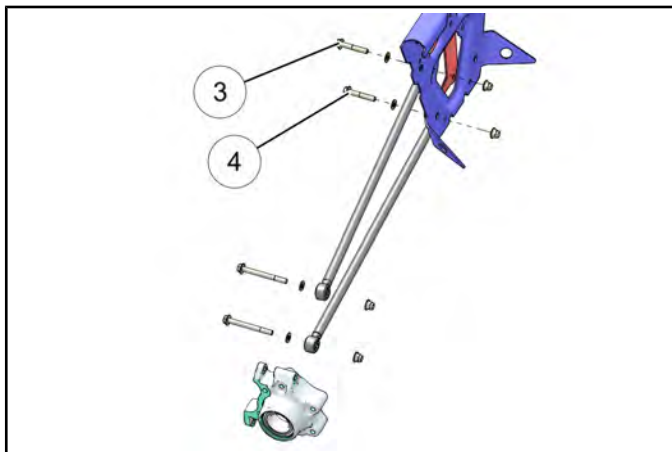

6. Remove radius rods from vehicle.

7. Examine radius rod shafts, boots and spherical bearings. Replace entire radius rod if any excessive wear is evident.
8. Reverse this procedure to reinstall the radius rods.
9. Torque all fasteners to specification.

**NOTE: Use new attaching nuts upon installation of the rear radius rods.**



Radius Rod Mounting Bolts:  
**40 ft-lb (54 Nm)**

#### WARNING

Upon radius rod installation, test vehicle at low speeds before putting into service.

## REAR TRAILING ARM

### Trailing Arm Removal / Installation

**NOTE:** Use new attaching nuts upon installation of the rear trailing arm and bearing carrier.

1. Raise and support vehicle by main frame.

#### CAUTION

Serious injury may result if machine tips or falls. Be sure machine is secure before beginning this service procedure.

2. Remove the four wheel nuts and remove the rear wheel.
3. Remove the cotter pin (Item 1) and loosen the rear wheel hub castle nut (Item 2). Remove the nut, and two cone washers (Item 3) from the rear wheel hub assembly.

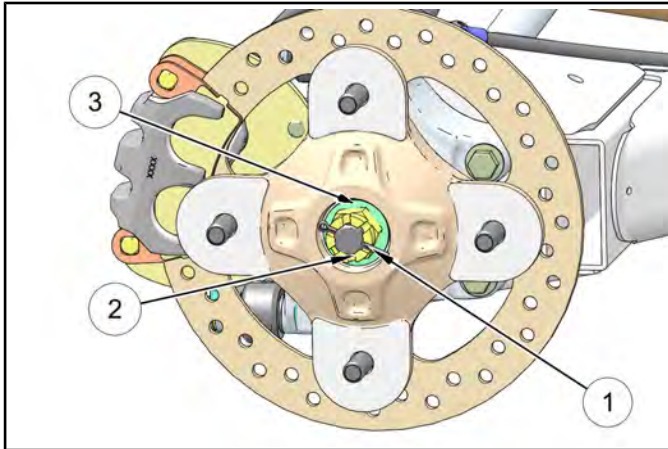

4. Remove the lower radius rod mounting bolt (Item 4), nut and washer from the bearing carrier. Swing radius rod down. Discard the nut.

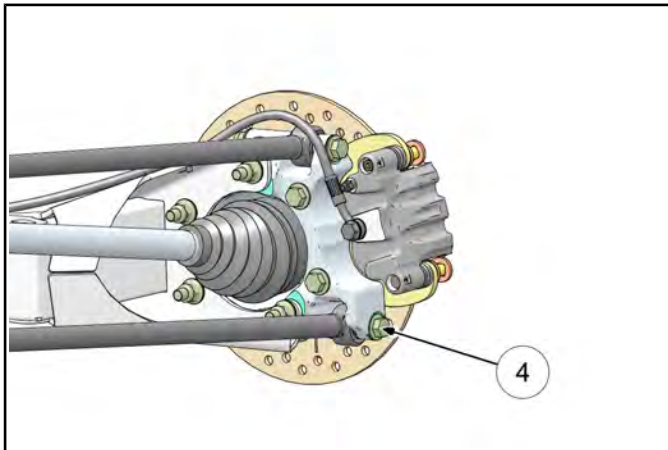

5. Remove the two brake caliper mounting bolts (Item 5).
6. **CAUTION:** Do not hang the caliper by the brake line. Use wire to hang caliper to prevent damage to the brake line.

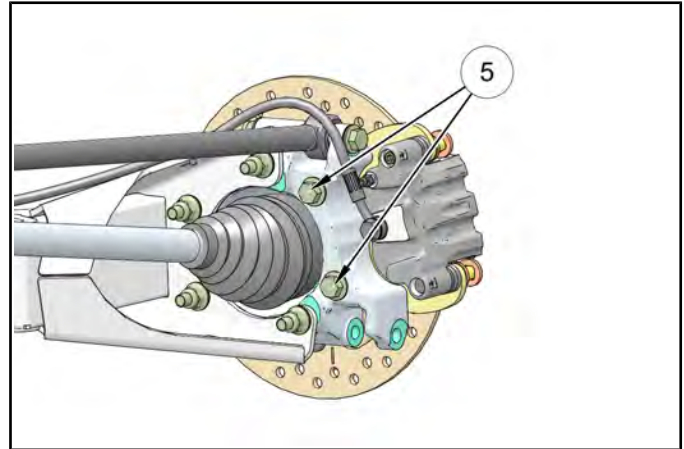

7. Remove the rear wheel hub and brake disk assembly.
8. Remove the five remaining bolts (Item 6) that attach the rear bearing carrier to trailing arm. Discard the nuts.

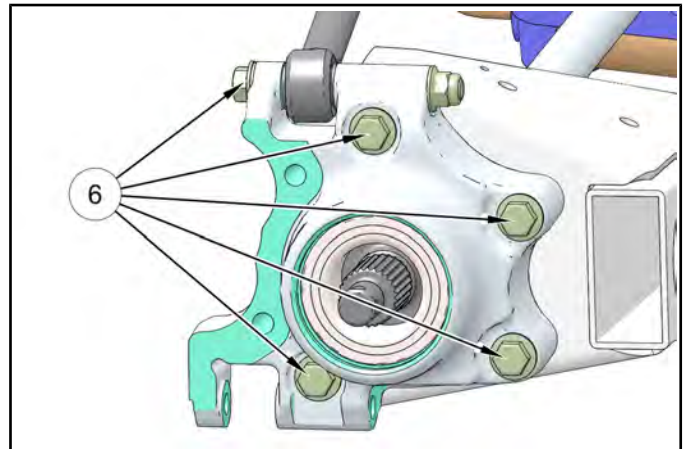

5

## BODY / STEERING / SUSPENSION

9. Remove the bearing carrier from the rear drive shaft and trailing arm.

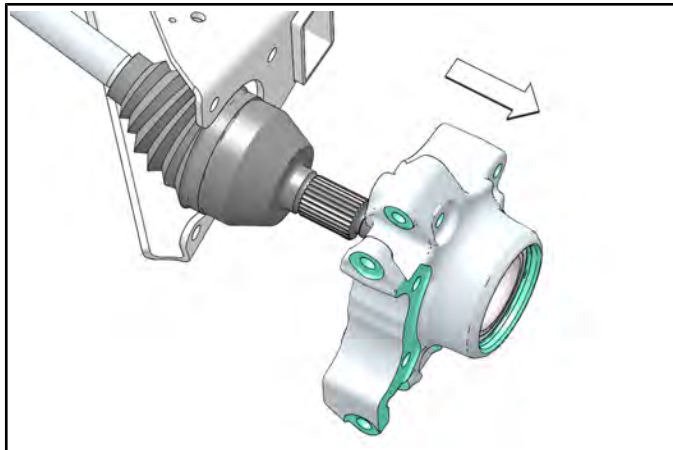

10. Rotate bearing by hand and check for smooth rotation. Visually inspect bearing for moisture, dirt, or corrosion. Replace bearing if moisture, dirt, corrosion, or roughness is evident (see Chapter 7).
11. Remove the four fasteners (Item 7) that secure the brake line retainers to the trailing arm.
12. Remove the lower stabilizer bar linkage fastener. Discard the nut.
13. Support trailing arm with suitable jack stand or support.
14. Remove the lower shock bolt. Discard the nut.

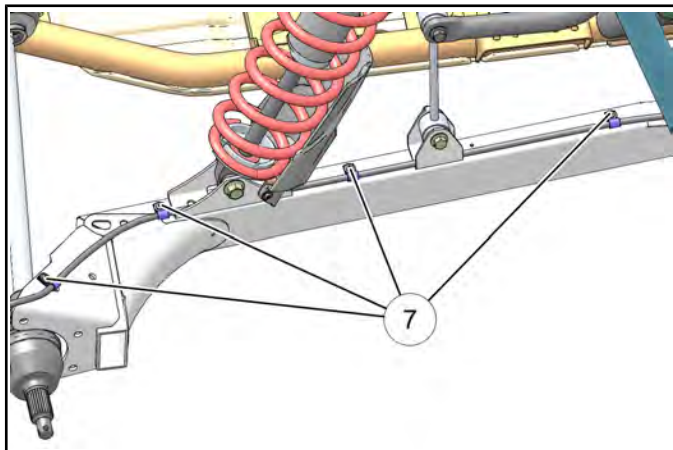

15. Remove the front trailing arm bolt (Item 8). Discard the nut.

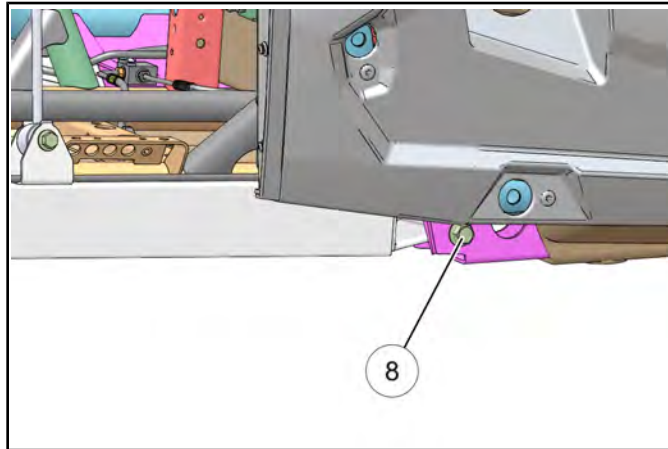

16. Remove trailing arm from vehicle. Visually inspect trailing arm, bushings, o-rings and spherical bearing for wear. If bearing requires replacement, refer to "Trailing Arm Spherical Bearing Replacement".
17. Replace trailing arm if physically damaged.
18. Reverse this procedure to reinstall rear trailing arm.
- NOTE: Use new fastener nuts upon installation of the rear trailing arm and bearing carrier.**
19. Torque all fasteners to specification.



Trailing Arm to Main Frame:  
(Trailing arm spherical bearing bolt)  
**70 ft-lb (95 Nm)**

Rear Shock Mounting Bolts:  
**70 ft-lbs (95 Nm)**

Rear Stabilizer Bar Linkage:  
**40 ft-lbs (54 Nm)**

Radius Rod Mounting Bolts:  
**40 ft-lb (54 Nm)**

Bearing Carrier to Trailing Arm Bolts:  
**42 ft-lb (54 Nm)**

Rear Brake Caliper Mounting Bolts:  
**40 ft-lbs (54 Nm)**

Rear Wheel Hub Castle Nut:  
**110 ft-lbs (149 Nm)**

Wheel Nuts:  
**120 ft-lbs (163 Nm)**

 **WARNING**

Upon rear trailing arm installation, test vehicle at low speeds before putting into service.

### Trailing Arm Spherical Bearing Replacement

1. Remove trailing arm (see “REAR TRAILING ARM”).
2. Remove bushings and O-rings.
3. Remove snap ring (Item 1) that retains the spherical bearing.



5

4. Properly support the trailing arm and press the spherical bearing out of trailing arm casting.
5. Be sure to only press on outer most surface of bearing race, do not press on the center spherical bearing.

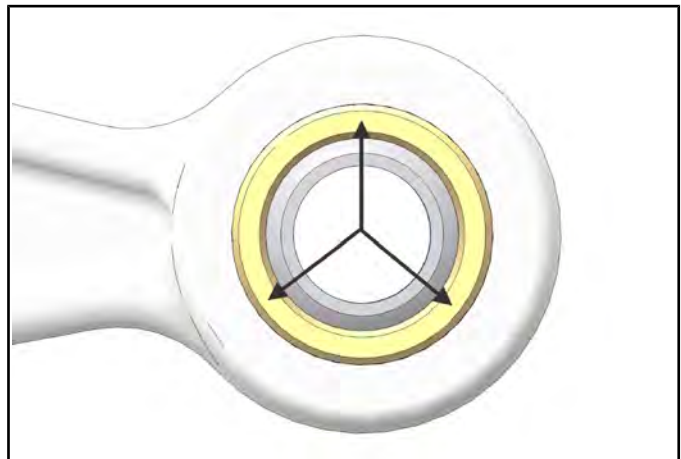

6. Inspect trailing arm bearing housing for wear or damage. Replace trailing arm if damaged.
7. Press in new bearing until fully seated into trailing arm casting.
8. Install **new** snap ring, O-rings (not required) and bushings.



# BODY / STEERING / SUSPENSION

## Rear Suspension Assembly View

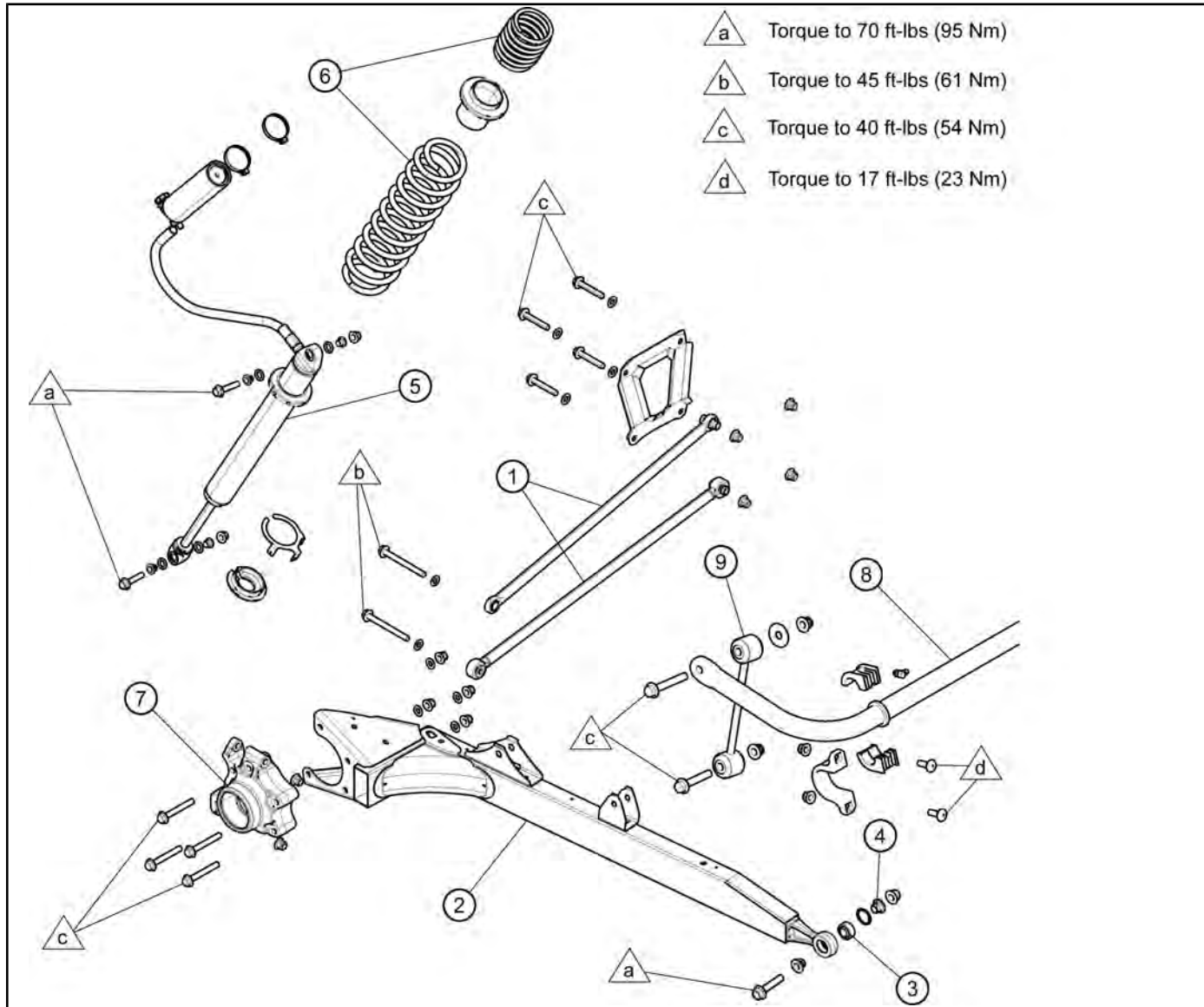

1. Radius Rod	2. Trailing Arm	3. Spherical Bearing
4. Bushing	5. Shock	6. Spring
7. Bearing Carrier	8. Stabilizer Bar	9. Stabilizer Bar Link

## REAR STABILIZER BAR

### Stabilizer Bar Removal

1. Lift and support vehicle by main frame.
2. Remove rear wheels nut and wheels.
3. Identify / mark top side of the stabilizer bar to reference during installation.
4. Remove the fasteners retaining the stabilizer bar to the linkage (Item 1) on each side of the vehicle.

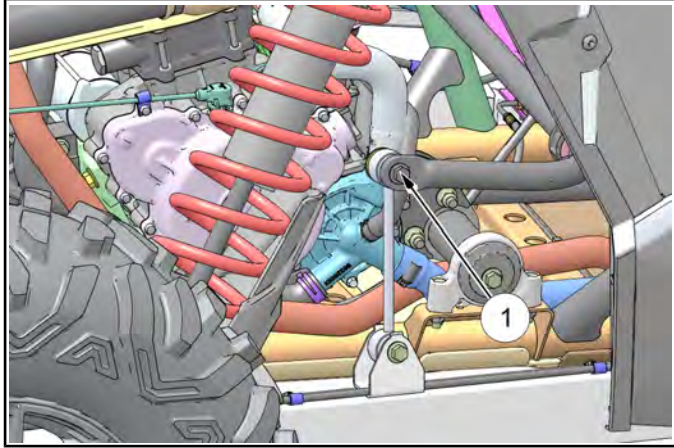

5. Lubricate stabilizer bar pivot bushings via grease fitting (fittings are accessible through skid plate).
6. Install rear wheels and wheel nuts. Torque wheel nuts to specification.



Rear Stabilizer Bar Linkage:  
**40 ft-lbs (54 Nm)**

Rear Stabilizer Bar Locating Clamp:  
**10 ft-lb (14 Nm)**

Wheel Lug Nuts:  
**120 ft-lbs (163 Nm)**

5. Remove the (4) fasteners retaining the stabilizer bar to the vehicle frame (see below).
6. Remove the bushing brackets and bushings for ease of removal.
7. Carefully remove the stabilizer from the LH wheel well area of the vehicle.
8. Mark the location and remove the two stabilizer bar locating clamps (if replacing stabilizer bar).
9. Inspect the stabilizer bar for straightness. Inspect the pivot bushings and replace if needed.

### Stabilizer Bar Installation

1. Carefully install stabilizer bar through the LH wheel well area.

**NOTE: Be sure fuel lines and shift cable are routed ABOVE the stabilizer bar.**

2. Fully install stabilizer bar, bushings, bracket and bracket fasteners and stabilizer links. Center stabilizer bar in the frame. Torque fasteners to specification (see below).
3. Install stabilizer bar locating clamps on the INSIDE of the pivot bushing and brackets. There should be a 0.10" (2.5mm) gap between the bushing face and the locating clamps. Torque locating clamps fasteners to specification.
4. Torque all fasteners to specification (see below).

# BODY / STEERING / SUSPENSION

## SHOCKS / SPRINGS / FASTENERS

### Front Shock Assembly View

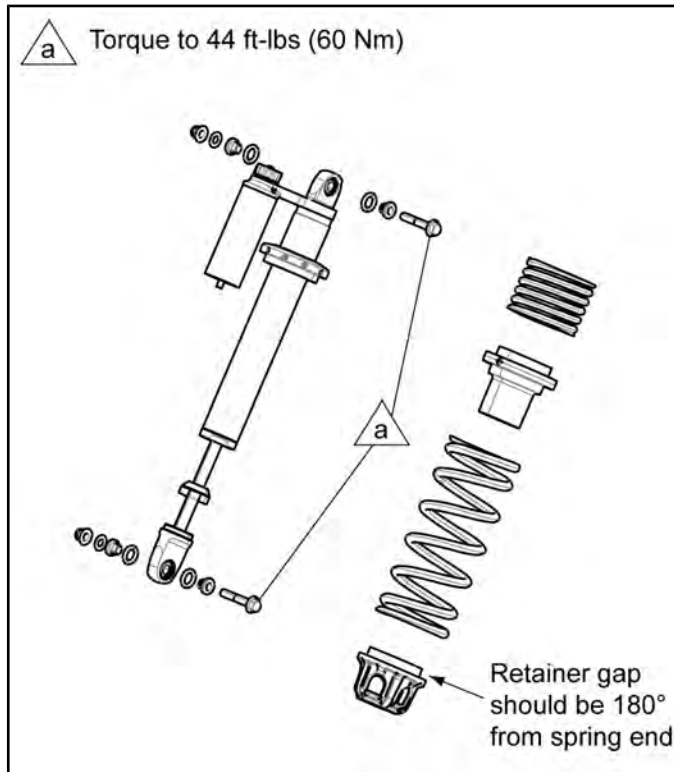

### Rear Shock Assembly View

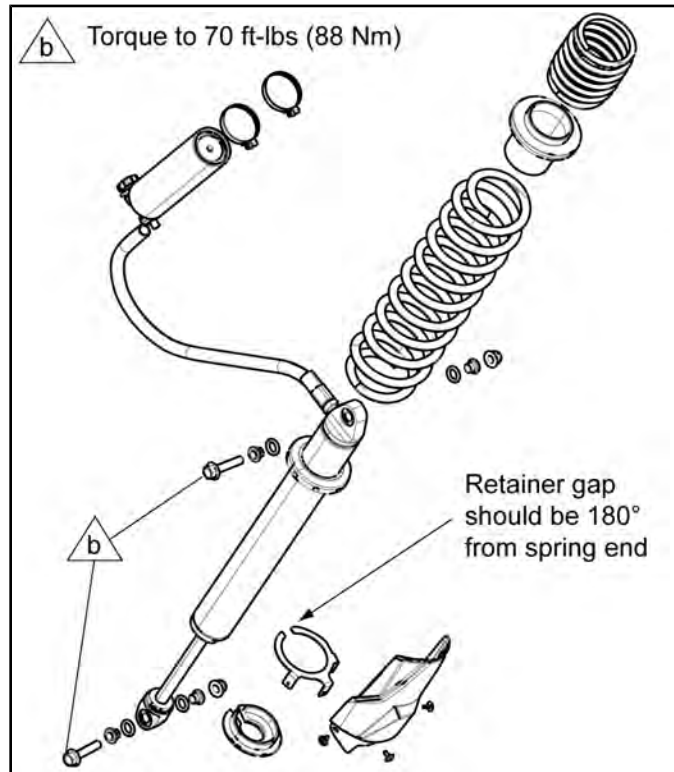

### Shock Removal / Installation

1. Elevate the vehicle off the ground to relieve the suspension load.
2. Support under A-arm or trailing arm.
3. Remove the upper and lower fasteners retaining the shock and remove the shock from the vehicle. Discard nuts and replace with new upon installation.
4. Reverse the procedure to reinstall the shock. Torque new fasteners to specification (refer to exploded views).



Shock Mounting Bolts:  
Front:  
**44 ft-lb (60 Nm)**  
Rear:  
**70 ft-lbs (95 Nm)**

5

### Shock Replacement

1. Remove the shock and note the spring preload distance (see Chapter 2 for factory settings).
2. Loosen the jam nut (if applicable) and adjustment ring until the spring is loose. If needed, use a spring compressor to compress the spring far enough to remove the spring retainer.
3. Remove the spring and spring retainer from the existing shock and install components onto the new shock.
4. Install the spring(s) and spring retainer.  
**NOTE: The spring retainer gap should be 180° from the end of the spring upon installation.**
5. Tighten the spring adjustment ring to set the preload distance noted in Step 1 (see Chapter 2 for factory settings).
6. Reinstall the shock onto the vehicle and torque new fasteners to specification.

# BODY / STEERING / SUSPENSION

## WALKER EVANS™ SHOCK ASSEMBLY VIEWS

### Walker Evans™ 2.0" Front Shock

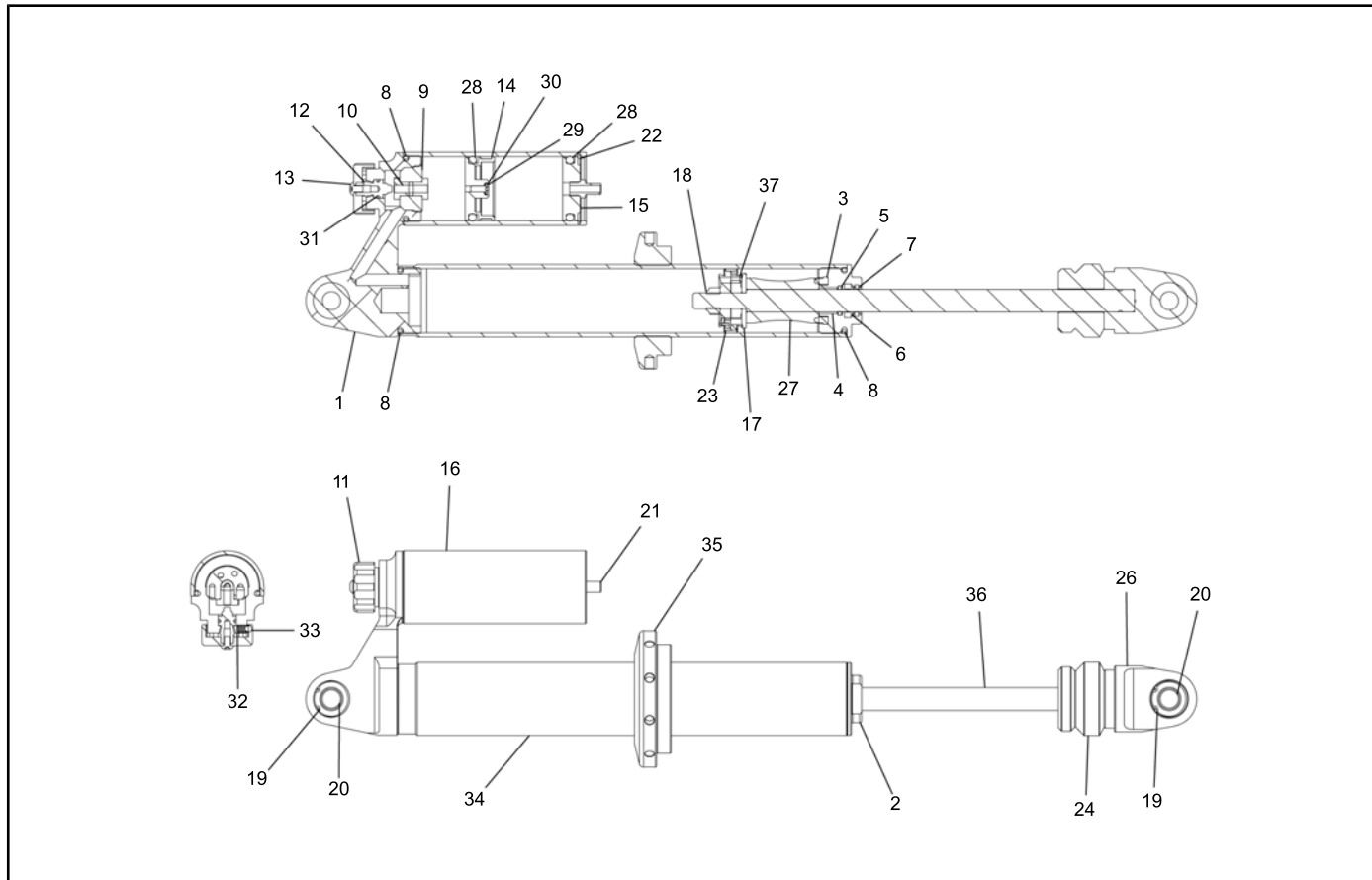

REF	DESCRIPTION	REF	DESCRIPTION	REF	DESCRIPTION
1.	Body Cap Asm.	14.	Piston Asm, Floating (IFP)	27.	Shaft Spacer (1.235" x 1.985")
2.	Seal Head Asm.	15.	Reservoir End Cap	28.	O-Ring
3.	Internal Bump Stop	16.	Reservoir Body	29.	Screw (8/32")
4.	Shaft Bushing (0.625")	17.	Washer (1.50" x 0.125" x 0.348")	30.	O-Ring
5.	O-Ring	18.	Crimp Nut (7/16")	31.	O-Ring
6.	Seal	19.	Snap Ring	32.	Detent Spring
7.	Wiper	20.	Spherical Bearing	33.	Detent Ball
8.	O-Ring	21.	Schraeder Valve	34.	Shock Body
9.	Piston, Clicker	22.	Snap Ring	35.	Spring Adjustment Nut
10.	Clicker Bolt	23.	Piston Wear Band (1.750" OD)	36.	Shaft, Chrome
11.	Clicker Knob	24.	Bump Stop	37.	2-Piece Piston Asm.
12.	Clicker Stud	25.	N/A		
13.	Screw (10/32")	26.	Shaft Loop		

## BODY / STEERING / SUSPENSION

### Walker Evans™ 2.5" Rear Shock

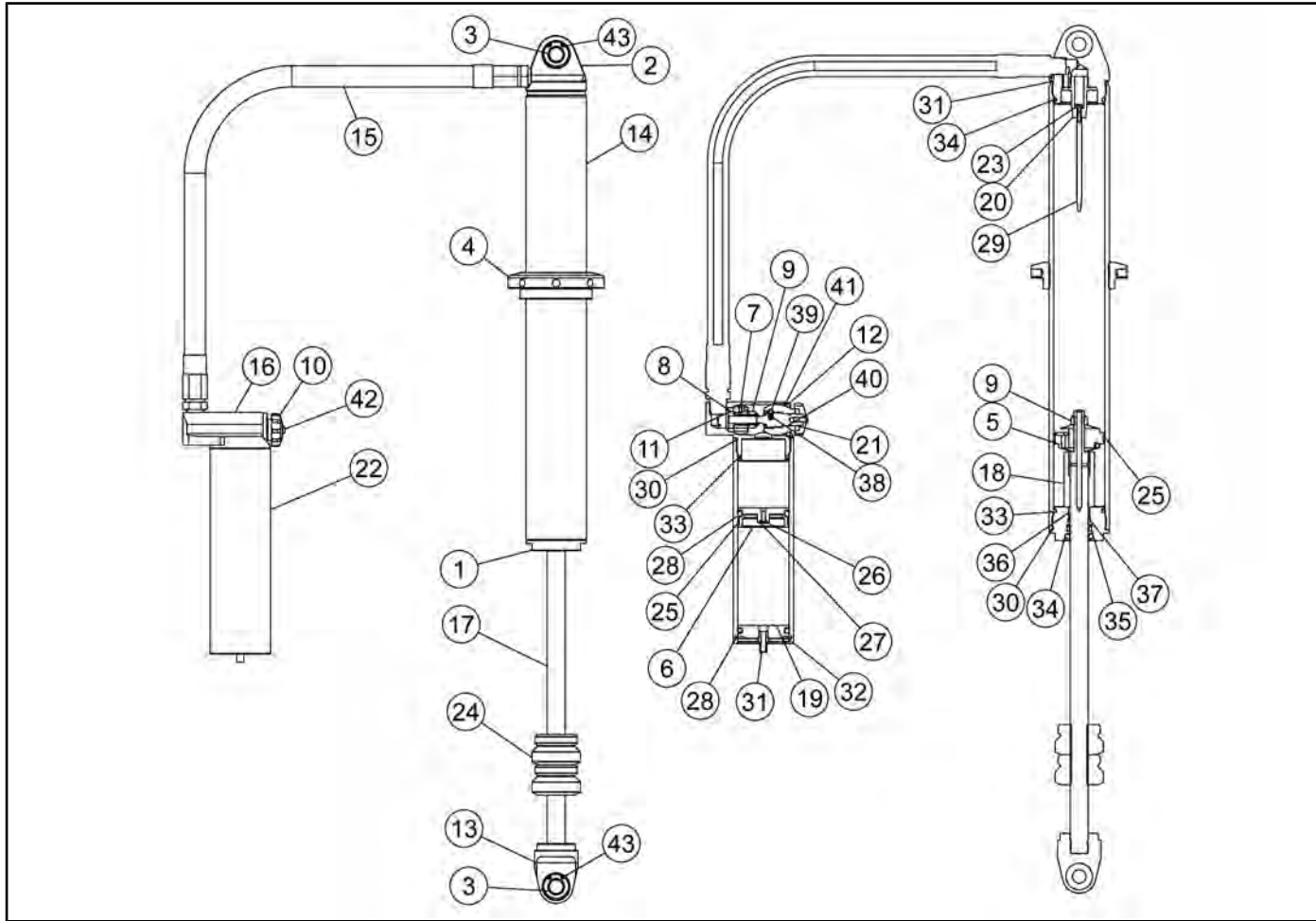

5

REF	DESCRIPTION	REF	DESCRIPTION	REF	DESCRIPTION
1.	Seal Head Asm.	16.	Adjuster Mount	31.	Schraeder Valve
2.	Bearing w/ Needle Slot	17.	Needle Shaft	32.	Snap Ring
3.	Spherical Bearing	18.	Spacer	33.	O-Ring
4.	Spring Nut	19.	End Cap	34.	Wiper
5.	Piston	20.	Needle Bolt	35.	Shaft Seal
6.	Reservoir Piston	21.	Adjuster Nut	36.	Shaft Bushing (0.750")
7.	Check Valve	22.	Reservoir Body	37.	O-Ring
8.	Clicker Bolt	23.	Bleed Screw	38.	Detent Spring
9.	Crimp Nut	24.	Bump Stop	39.	Detent Ball
10.	Adjuster Knob	25.	Wear Band	40.	O-Ring
11.	Ball (.250")	26.	O-Ring	41.	O-Ring
12.	Retention Nut	27.	Screw	42.	Screw
13.	9/16 Heim Shaftloop	28.	O-Ring	43.	Snap Ring
14.	Shock Body	29.	Needle		
15.	Hose	30.	O-Ring		

5.49

# BODY / STEERING / SUSPENSION

## WALKER EVANS™ SHOCK SERVICE

### General Service Information

#### Recommended Service Intervals

Walker Evans™ Racing Shocks will perform the best if serviced at regular intervals:

- Every ride - Wash and dry the vehicle and suspension
- Every 100 hours - Visually inspect shock seals
- Every 1500 miles or Annually - Change shock oil and replace seals

### Front Shock Service Information

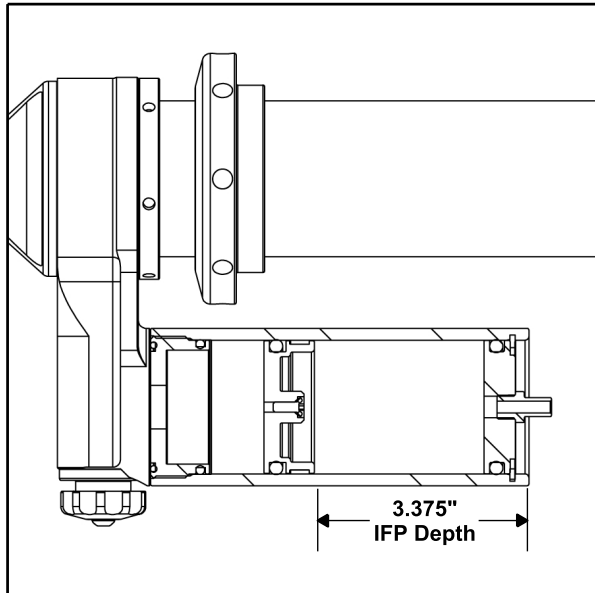

FRONT SHOCK DESIGN DETAILS	
Travel	8.42" (21.39 mm)
Extended Length	25.10" (63.75 mm)
IFP Location	3.375" (85.7 mm)
Nitrogen Pressure	125 psi +/- 5%
Gas Shock Oil	2874124 (qt.)

### Front Shock Valving RZR XP 1000

COMPRES-SION	REBOUND	CLICKER
1.55 x 0.008	1.50 x 0.01	1.10 x 0.025
1.00 x 0.015	1.10 x 0.01	1.00 x 0.025
1.55 x 0.008	1.45 x 0.01	1.00 x 0.025
1.55 x 0.008	1.30 x 0.01	0.625 x 0.065
1.55 x 0.008	1.20 x 0.01	
1.55 x 0.008	1.10 x 0.01	
1.55 x 0.008	1.00 x 0.01	
1.45 x 0.010	0.90 x 0.01	
1.30 x 0.008	0.75 x 0.065	
Piston Bleed Orifice: none		

### Front Shock Valving RZR XP 4 1000

COMPRES-SION	REBOUND	CLICKER
1.55 x 0.008	1.50 x 0.01	1.10 x 0.025
1.00 x 0.015	1.10 x 0.01	1.00 x 0.025
1.55 x 0.008	1.45 x 0.01	1.00 x 0.025
1.55 x 0.008	1.30 x 0.01	0.625 x 0.065
1.55 x 0.008	1.20 x 0.01	
1.55 x 0.008	1.10 x 0.01	
1.55 x 0.008	1.00 x 0.01	
1.45 x 0.010	0.90 x 0.01	
1.30 x 0.008	0.75 x 0.065	
1.20 x .012		
1.10 x .012		
Piston Bleed Orifice: none		

# BODY / STEERING / SUSPENSION

## Rear Shock Service Information

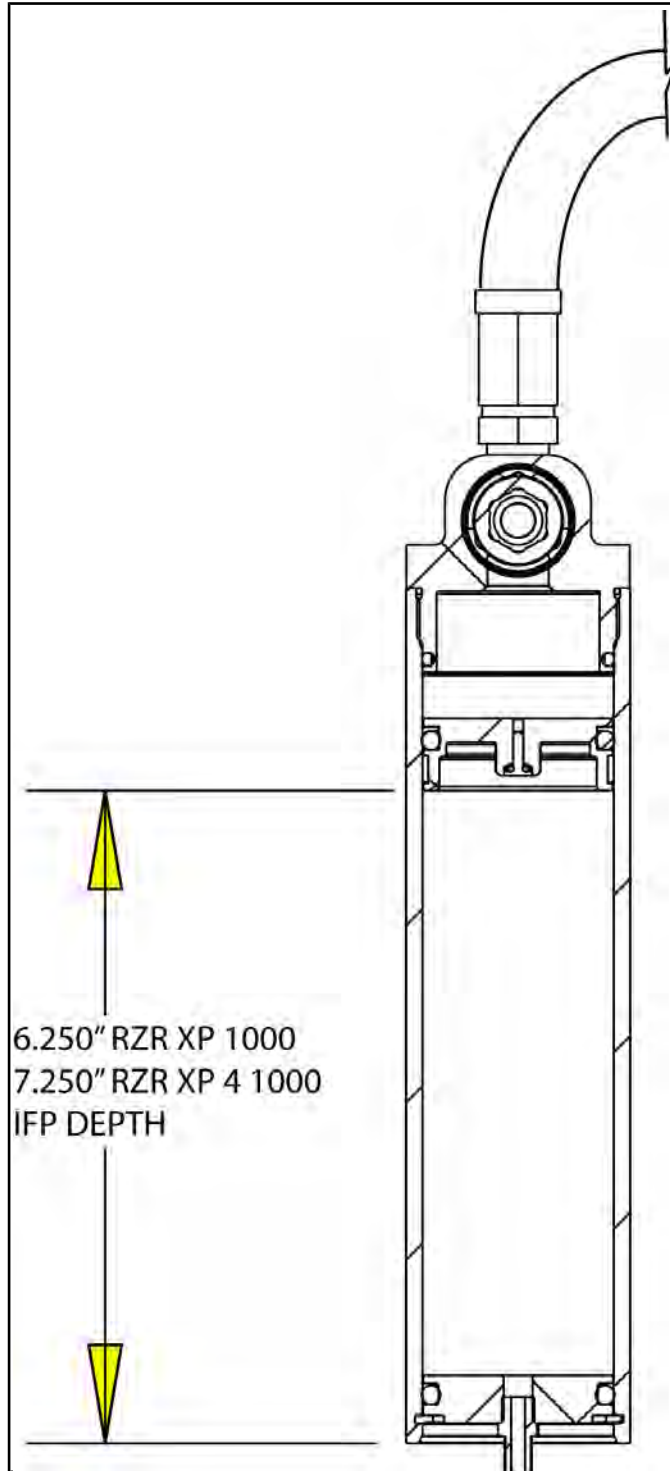

REAR SHOCK DESIGN DETAILS	
Travel	12.09" (30.71 mm)
Extended Length	34.36" (87.27 mm)
IFP Location <i>RZR XP 1000</i>	6.25" (158.8 mm)
IFP Location <i>RZR XP 4 1000</i>	7.25" (184.15 mm)
Nitrogen Pressure	125 psi (862 kPa) +/- 5%
Gas Shock Oil P/N	2874124 (qt.)

### Shock Valving *RZR XP 1000*

COMPRES- SION	REBOUND	CLICKER
1.55 x 0.008	1.500 x 0.01	1.00 x 0.015
1.00 x 0.010	1.45 x 0.01	1.00 x 0.015
1.55 x 0.008	1.30 x 0.01	0.90 x 0.015
1.55 x 0.008	1.20 x 0.01	0.70 x 0.015
1.55 x 0.008	1.10 x 0.01	0.70 x 0.015
1.55 x 0.008	1.00 x 0.01	
1.55 x 0.008	0.90 x 0.01	
1.45 x 0.010	0.80 x 0.01	
1.30 x 0.012	0.75 x 0.065 (top-out)	
1.20 x 0.012		
1.50 x 0.125 (top-out)		
Piston Bleed Orifice: 0.100"		

5



# BODY / STEERING / SUSPENSION

## Shock Valving RZR XP 4 1000

COMPRES- SION	REBOUND	CLICKER	
1.55 x 0.008	1.500 x 0.01	1.00 x 0.015	
1.00 x 0.010	1.45 x 0.01	1.00 x 0.015	
1.55 x 0.008	1.30 x 0.01	0.90 x 0.015	
1.55 x 0.008	1.20 x 0.01	0.60 x 0.015	
1.55 x 0.008	1.10 x 0.01	0.60 x 0.015	
1.55 x 0.008	1.00 x 0.01		
1.55 x 0.008	0.90 x 0.01		
1.45 x 0.010	0.80 x 0.01		
1.10 x 0.012	0.75 x 0.065 (top-out)		
1.00 x 0.012			
1.50 x 0.125 (top-out)			
Piston Bleed Orifice: 0.100"			

PART NUMBER	DESCRIPTION
PS-50931	Shock Rod Holding Tool - Rear
PU-50939	Shock Seal Protector Sleeve - Front
PU-50952	Shock Seal Protector Sleeve - Rear

### Valve Shim Arrangement

Shown below is an example of how valving stacks are arranged.

**NOTE:** The rebound and compression valve stacks will always be positioned as shown in the illustration, regardless of how the shock assembly is installed.

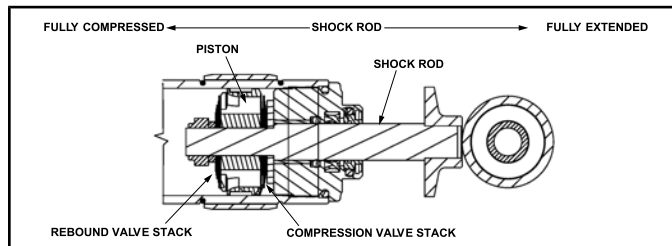

### Walker Evans™ Shock Rebuild Information

When performing maintenance on Walker Evans™ shocks, use the Gas Shock Recharging Kit (PN 2200421), as it contains the necessary valves, pressure gauge, and fittings to deflate and pressurize shocks.

**WARNING**

Walker Evans™ shocks contain high pressure nitrogen gas. Extreme caution must be used while handling and working with Walker Evans™ shocks and related high pressure service equipment. The pressure must be released from the shock before disassembly. It is strongly recommended you wear safety glasses and ear protection during these procedures.

### Piston Orientation

The face of the piston with the greater number of relief ports will always face the rebound valve stack.

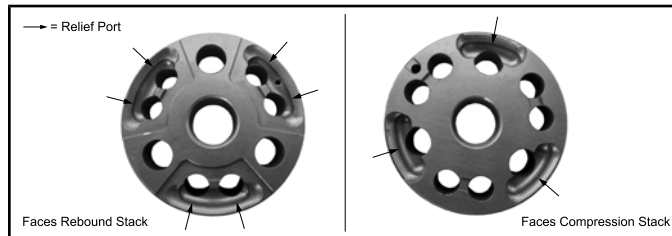

### Special Tools

PART NUMBER	DESCRIPTION
2200421	Gas Shock Recharging Kit
PS-45908	IFP Tool
PU-50979	Shock Body Holding Tool - Front
PU-50938	Shock Body Holding Tool - Rear
2872429	Shock Rod Holding Tool - Front

## Walker Evans™ Shock Disassembly

**NOTE:** To prevent damage or marks to the shock, the use of special tools and a soft jaw vise is recommended.

### WARNING

Walker Evans™ shocks contain high pressure nitrogen gas. Extreme caution must be used while handling and working with Walker Evans™ shocks and related high pressure service equipment. The pressure must be released from the shock before disassembly. It is strongly recommended you wear safety glasses and ear protection during these procedures.

1. Clean and carefully remove shock from the vehicle.
2. Back preload adjuster all the way down and carefully remove spring retainer and spring(s).

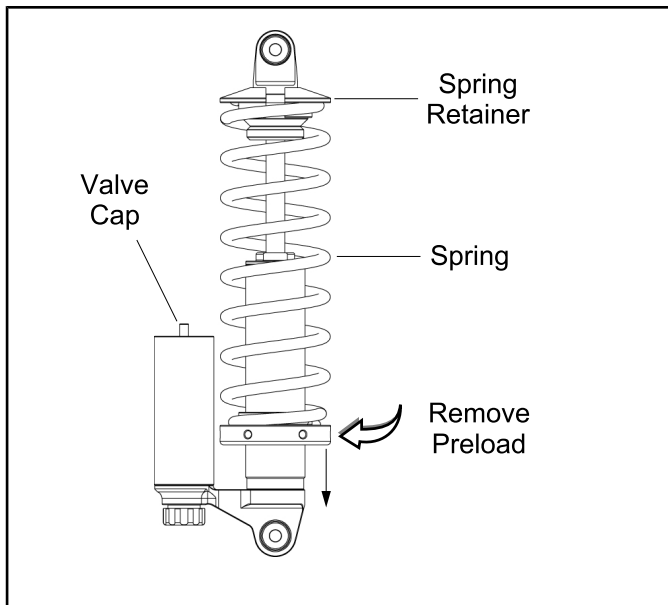

3. Use the appropriate shock body holding tool to properly secure the shock assembly into a vise for service.

**Front Shock Body Holding Tool: PU-50979**  
**Rear Shock Body Holding Tool: PU-50938**

4. Remove the valve cap from the valve fitting on the top of the reservoir.

5. Carefully depressurize the shock.



6. Using a snap ring pliers, remove the retaining ring from the reservoir.



7. Carefully remove the cap from the reservoir body.



5

## BODY / STEERING / SUSPENSION

8. Using a 1" open-end wrench or adjustable wrench, loosen and remove the bearing cap from the shock body.



9. Slowly lift up and remove the shock rod assembly from the shock body.



10. Remove and properly dispose of the oil from the shock body.

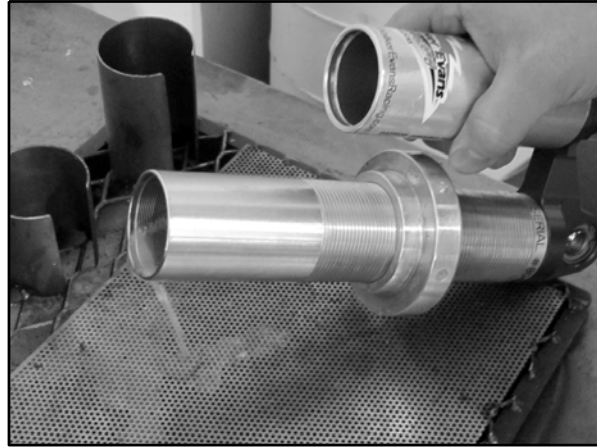

**NOTE:** Insert the IFP Tool (PS-45908) and cycle the Internal Floating Piston (IFP) a few times to purge the shock oil from the reservoir.

11. Remove the floating piston from the shock reservoir using the IFP Tool (PS-45908).

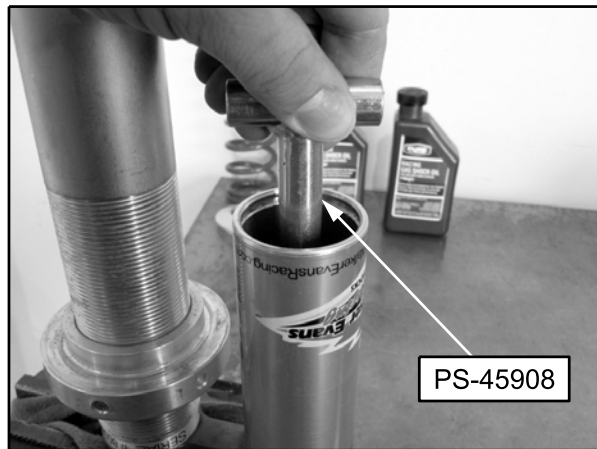

12. Clean and inspect ALL parts and replace as needed.

**NOTE:** Seal kits are available and should be installed at this time if seals or O-rings are damaged or worn.

13. Use the appropriate shock rod holding tool and a vise to mount the shock rod vertically with the threaded end upward.

**Front Shock Rod Holding Tool: 2872429**  
**Rear Shock Rod Holding Tool: PU-50931**

## BODY / STEERING / SUSPENSION

14. Using an 11/16" socket, remove the nut retaining the valve stack and piston.



**NOTE:** Keep the rebound and compression valve stacks in the order they were removed. If unsure of order, refer to "Shock Valving" under the "Shock Service Information" provided earlier in this section.

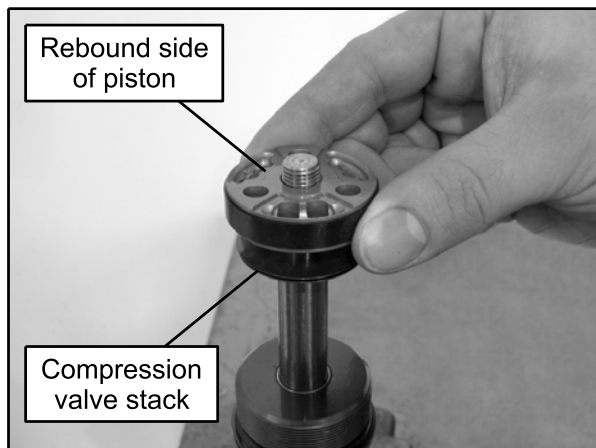

15. Place the valve stack on a clean shop towel in order of removal.
16. Inspect the valves for kinks, waves, pits or foreign material.
17. Inspect the piston wear band and replace if damaged or worn.
18. Use the appropriate shock body holding tool to properly secure the shock assembly into a vice for service.

**Front Shock Body Holding Tool: PU-50979**  
**Rear Shock Body Holding Tool: PU-50938**

19. **Front Shocks Only:** Using a 9/16" socket w/ extension, remove the fastener retaining the clicker valve stack. Place the valve stack on a clean shop towel in order of removal.

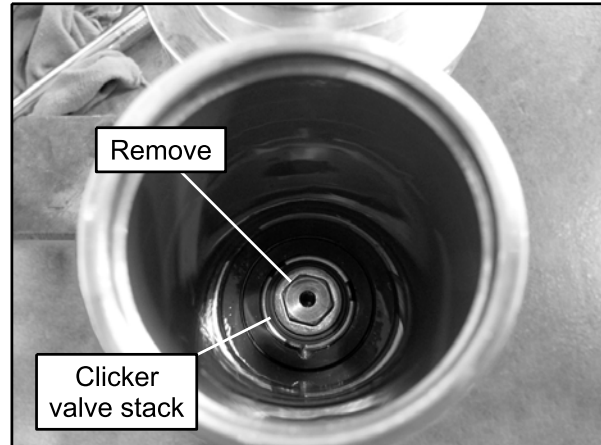

**NOTE:** Keep the valve stack in the order it was removed. If unsure of order, refer to "Shock Valving" under the "Shock Service Information" provided earlier in this section.

20. Inspect the valves for kinks, waves, pits or foreign material
21. Thoroughly clean all shock components and shock body prior to assembly.

### Walker Evans™ Shock Assembly

1. Install new seals and O-rings on the seal head assembly.
2. Use the appropriate shock rod holding tool and a vise to mount the shock rod vertically with the threaded end upward.

**Front Shock Rod Holding Tool: 2872429**  
**Rear Shock Rod Holding Tool: PU-50931**

3. Install the appropriate Shock Seal Protector Sleeve over the shaft threads.

**Front Shock Seal Protector Sleeve: PU-50939**  
**Rear Shock Seal Protector Sleeve: PU-50952**

4. Install seal head assembly onto the shock shaft.
5. Remove the Shock Seal Protector Sleeve.
6. Place the compression valve stack on the rod in the reverse order of disassembly.

## BODY / STEERING / SUSPENSION

7. Place valve piston on top of the compression stack.

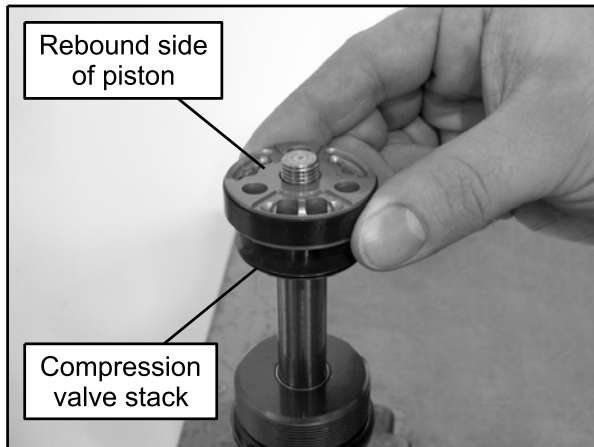

**NOTE:** If unsure of the valve stack order, refer to “Shock Valving” under the “Shock Service Information” provided earlier in this section.

8. Place a new lock nut onto the shock rod. Torque the new lock nut to specification.

**NOTE:** Do not over torque the nut or damage to the valve stack can occur.

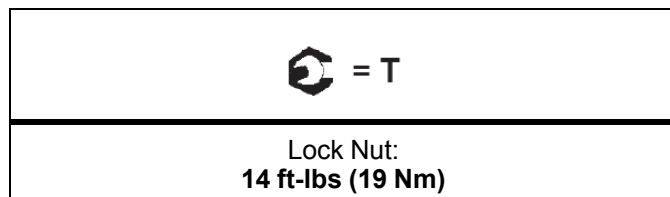

**NOTE:** Make sure “Top-Out” washers are orientated as shown.

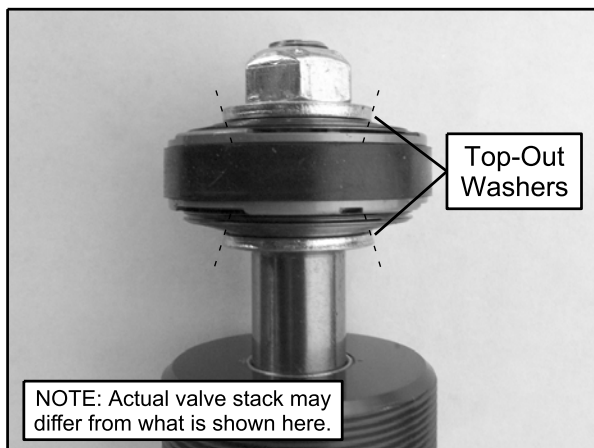

9. **Front Shocks Only:** Assemble the clicker valve stack on top of the fastener and install the assembly into the reservoir body. Tighten the valve stack fastener securely.



10. Turn the compression adjuster knob counter-clockwise (soft) until it stops, so damping is in the full open position.

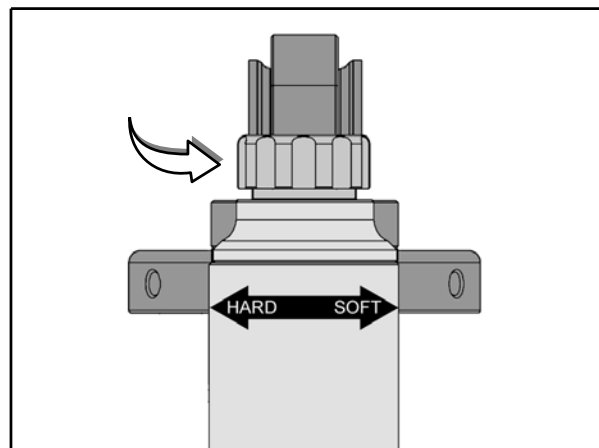

11. Use the appropriate shock body holding tool to properly secure the shock assembly into a vice for service.

**Front Shock Body Holding Tool: PU-50979**  
**Rear Shock Body Holding Tool: PU-50938**

## BODY / STEERING / SUSPENSION

12. Fill the shock body and remote reservoir 1/2 full of the recommended gas shock oil.

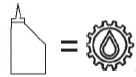

**Recommended Shock Oil:**  
Racing Gas Shock Oil (PN 2874124) (Quart)  
10 Weight for Walker Evans Shocks

13. Using a 3/32" Allen wrench, remove IFP bleed screw.



14. Apply a thin film of oil to IFP O-ring and wear band. Insert IFP into reservoir until completely submerged. Allow air to escape as you install the piston.



15. Screw IFP Tool (PS-45908) onto the floating piston.



16. Slowly cycle the IFP up and down.
- Be sure to bottom out piston in the reservoir body.
  - Allow time for the bubbles to dissipate.
  - Repeat the process until all air has been removed.

5

5.57

## BODY / STEERING / SUSPENSION

17. Pull IFP up until its top is approximately 1" (2.54 cm) from top of reservoir and remove the IFP Tool. Using a 3/32" Allen wrench, install the IFP bleed screw.



**NOTE:** When the IFP Tool is removed, the IFP must remain submerged in shock oil to prevent air from getting under the floating piston.

18. Fill the shock body with oil approximately 1/4" below the threads.
19. Apply a thin film of oil to the wear band on the damping piston. Slowly insert the shock rod assembly into the body until the damping piston assembly is approximately 1" below the oil surface.
  - Move rod up and down slowly over a range of about 1" until no air bubbles rise from damping piston. Be careful to keep damping piston at least 1/4" below the surface of the oil during this process.
  - While holding the shock rod, apply 2 - 3 sharp blows to the rod eyelet with a rubber mallet driving the piston down into the shock body. This opens the valves on the damping piston. You will see the released air bubbles come to the surface of the oil.

20. Add oil to the body tube until the surface of the oil is at the top of the shock body threads.



**NOTE:** During installation, some shock oil will over flow. Wrap a shop cloth around the shock body to catch any oil overflow.

21. Pull the damping piston up until it is just below the surface of the oil.
22. Hold the rod eyelet with one hand. With other hand, slide the bearing cap down the shaft until contact with the body is made. Oil will overflow from around the bearing cap.
23. Screw the bearing cap assembly into the shock body by hand, holding the rod up so that the bearing cap is in contact with the bottom of the damping piston assembly. Be careful not to cross-thread the bearing assembly.
24. Using a 1" open-end wrench, tighten the bearing cap.
25. Using a 3/32" Allen wrench, remove the IFP bleed screw.

## BODY / STEERING / SUSPENSION

26. Set the IFP depth to the specified length from the top of the reservoir.

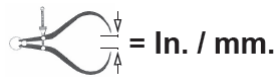
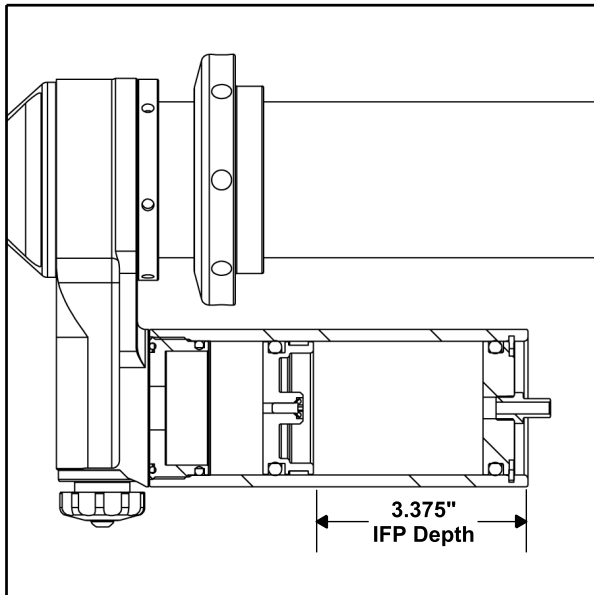

**IFP Depth:**  
**FRONT:** 3.375" (85.7 mm)  
**REAR RZR XP 1000:** 6.25" (158.8 mm)  
**REAR RZR XP 4 1000:** 7.25" (184.2 mm)

27. Using a long 3/32" Allen wrench, install the IFP bleed screw.

**NOTE:** Apply grease to the end of the Allen wrench so the bleed screw sticks to it during installation.

28. Pour the residual shock oil out of the reservoir into a proper disposal container.  
 29. Install the reservoir cap. Push down on the reservoir cap using even pressure until the retaining ring groove is exposed.  
 30. Install the retaining ring and check to make sure retaining ring is seated properly.  
 31. Push the shock rod assembly completely into the shock body. It should go all the way down smoothly without interference. If it does not, disassemble and reassemble per this procedure.  
 32. Secure the shock body in a vise by its lower mount.

33. Pressurize the shock reservoir through the Schrader® valve using the Gas Shock Recharging Kit (PN 2200421).

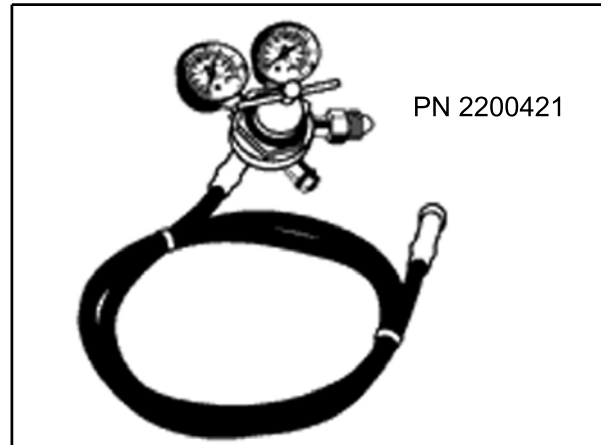

34. Continue filling until the shaft has fully extended and the reservoir pressure is at 125 psi.



**Nitrogen Pressure (Front and Rear):**  
**125 psi (862 kPa) +/- 5%**

**WARNING**

**CHARGE THE SHOCK USING NITROGEN GAS ONLY. DO NOT FILL WITH ANY OTHER GASES.**  
 Doing so compromises the performance of the shock and may be **EXTREMELY DANGEROUS!**

35. Reinstall the valve cap.  
 36. Clean all oil residue from the shock and reservoir with solvent, and dry with low pressure compressed air in a well ventilated area.

5

5.59



## BODY / STEERING / SUSPENSION

---

37. Check shock for any leaks.
38. Reinstall the compression spring and the spring retainer.
39. Thread the spring preload adjuster down against the spring and set the preload to the specified measurement (see Chapter 2).
40. Set the compression adjuster knob to the recommended setting or the original setting upon removal (see Chapter 2).
41. Remove the shock from the vise.
42. Reinstall spherical bearing O-rings and polyurethane bushings.

**NOTE:** After installation, be sure to **RIDE SLOWLY** initially to ensure the shock and the vehicle's suspension is performing correctly.

# CHAPTER 6

## CLUTCHING

GENERAL INFORMATION .....	6.2
SPECIAL TOOLS AND SUPPLIES .....	6.2
PVT SYSTEM TORQUE SPECIFICATIONS .....	6.2
2014 RZR XP / XP 4 1000 CLUTCH CHARTS .....	6.2
PVT SYSTEM OVERVIEW .....	6.3
GENERAL OPERATION .....	6.3
DRIVE CLUTCH OPERATION .....	6.3
DRIVEN CLUTCH OPERATION .....	6.3
PVT BREAK-IN (DRIVE BELT / CLUTCHES) .....	6.3
MAINTENANCE / INSPECTION .....	6.4
OVERHEATING / DIAGNOSIS .....	6.5
PVT SYSTEM SERVICE .....	6.6
PVT COVERS AND DUCT COMPONENTS .....	6.6
PVT DISASSEMBLY .....	6.7
PVT ASSEMBLY .....	6.8
DRIVE BELT .....	6.10
BELT REMOVAL .....	6.10
BELT INSPECTION .....	6.11
BELT INSTALLATION .....	6.11
PVT BREAK-IN (DRIVE BELT / CLUTCHES) .....	6.11
DRIVE CLUTCH SERVICE .....	6.12
DRIVE CLUTCH ASSEMBLY VIEW .....	6.12
DRIVE CLUTCH DISASSEMBLY / INSPECTION .....	6.13
NEEDLE BEARING INSPECTION .....	6.14
SHIFT WEIGHT INSPECTION .....	6.14
BUTTON TO TOWER CLEARANCE INSPECTION .....	6.15
SPIDER REMOVAL .....	6.15
ROLLER, PIN, AND THRUST WASHER INSPECTION .....	6.15
CLUTCH INSPECTION .....	6.16
MOVEABLE SHEAVE BUSHING INSPECTION .....	6.16
BUSHING SERVICE .....	6.17
DRIVE CLUTCH ASSEMBLY .....	6.19
DRIVEN CLUTCH SERVICE .....	6.22
CLUTCH DISASSEMBLY .....	6.22
BUSHING SERVICE .....	6.24
CLUTCH ASSEMBLY .....	6.26
ASSEMBLY VIEW .....	6.30
TROUBLESHOOTING .....	6.31

# CLUTCHING

## GENERAL INFORMATION

### SPECIAL TOOLS AND SUPPLIES

PART NUMBER	TOOL DESCRIPTION
2872085	Drive Clutch Puller
2871056	Driven Clutch Puller
9314177	Clutch Holding Wrench
2871358-A	Clutch Holding Fixture
PU- 50578	Spider Jam Nut Socket
2870341	Clutch Spider Removal and Installation Tool
2870910	Roller Pin Tool
2871226	Drive Clutch Bushing Replacement Tool Kit
2870386	Piston Pin Puller
PU-50518	Driven Clutch Compression Tool
2877408	Shock Spanner / Clutch Spreader

**Bosch Automotive Service Solutions:** 1-800-345-2233 or <http://polaris.service-solutions.com/>

SPECIAL SUPPLIES	PART NUMBER
Loctite® 620™ 648™ and 7088™ Primer	N/A
RTV Silicone Sealer	8560054

### PVT System Torque Specifications

ITEM	TORQUE VALUE
Drive Clutch Retaining Bolt	<b>96 ft-lb (130 Nm)</b>
Driven Clutch Retaining Bolt	<b>55 ft-lb (75 Nm)</b>
PVT Inner Cover Bolts	<b>12 ft-lb (16 Nm)</b>
PVT Outer Cover Screws	<b>48 in-lb (5 Nm)</b>
Spider Jamb Nut	<b>250 ft-lb (339 Nm)</b> (Apply 0.1 mL Loctite® 7088 Primer and 0.1 mL Loctite® 620™)
Drive Clutch Spider	<b>290 ft-lb (393 Nm)</b> (Apply 0.4 mL Loctite® 7088 Primer and 0.4 mL Loctite® 620™)
Drive Clutch Cover Plate	<b>9 ft-lb (12 Nm)</b>

ITEM	TORQUE VALUE
Shift Weight Fasteners	<b>20 in-lb (2 Nm)</b>
Driven Clutch Helix Retaining Screws	<b>48 in-lb (5 Nm)</b>

### 2014 RZR XP / XP 4 1000 CLUTCH CHARTS

#### CLUTCH CHART (2014 RZR XP 1000 / EPS / INT'L)

ALTITUDE		SHIFT WEIGHT	DRIVE SPRING	DRIVEN SPRING
Meters (Feet)	0-1500 (0-5000)	26-61 (1323098)	White / Orange (7043924)	Red (3234452)
	1500-3700 (5000 - 12000)	26-55 (1322982)	White / Orange (7043924)	Red (3234452)

#### CLUTCH CHART (2014 RZR XP 4 1000)

ALTITUDE		SHIFT WEIGHT	DRIVE SPRING	DRIVEN SPRING
Meters (Feet)	0-1500 (0-5000)	26-67 (1323177)	White / Orange (7043924)	Red (3234452)
	1500-3700 (5000 - 12000)	26-61 (1323098)	White / Orange (7043924)	Red (3234452)

## PVT SYSTEM OVERVIEW

### General Operation



All PVT maintenance or repairs should be performed by a certified Polaris Master Service Dealer (MSD) technician who has received the proper training and understands the procedures outlined in this manual.

**Because of the critical nature and precision balance incorporated into the PVT components, it is absolutely essential that no disassembly or repair be made without factory authorized special tools and service procedures.**

The Polaris Variable Transmission (PVT) consists of three major assemblies:

- 1) The Drive Clutch
- 2) The Driven Clutch
- 3) The Drive Belt

The internal components of the drive clutch and driven clutch control engagement (initial vehicle movement), clutch upshift and backshift. During the development of the Polaris vehicle, the PVT system is matched first to the engine power curve; then to average riding conditions and the vehicle's intended usage. Therefore, modifications or variations of components at random are never recommended. Proper clutch setup and careful inspection of existing components must be the primary objective when troubleshooting and tuning.

### Drive Clutch Operation

Drive clutches primarily sense engine RPM. The two major components which control its shifting function are the shift weights and the coil spring. Whenever engine RPM is increased, centrifugal force is created, causing the shift weights to push against rollers on the moveable sheave, which is held open by coil spring preload. When this force becomes higher than the preload in the spring, the outer sheave moves inward and contacts the drive belt. This motion pinches the drive belt between the spinning sheaves and causes it to rotate, which in turn rotates the driven clutch.

At lower RPM, the drive belt rotates low in the drive clutch sheaves. As engine RPM increases, centrifugal force causes the drive belt to be forced upward on drive clutch sheaves.

### Driven Clutch Operation

Driven clutches primarily sense torque, opening and closing according to the forces applied to it from the drive belt and the transmission input shaft. If the torque resistance at the transmission input shaft is greater than the load from the drive belt, the drive belt is kept at the outer diameter of the driven clutch sheaves.

As engine RPM and horsepower increase, the load from the drive belt increases, resulting in the belt rotating up toward the outer diameter of the drive clutch sheaves and downward into the sheaves of the driven clutch. This action, which increases the driven clutch speed, is called upshifting.

Should the throttle setting remain the same and the vehicle is subjected to a heavier load, the drive belt rotates back up toward the outer diameter of the driven clutch and downward into the sheaves of the drive clutch. This action, which decreases the driven clutch speed, is called backshifting.

In situations where loads vary (such as uphill and downhill) and throttle settings are constant, the drive and driven clutches are continually shifting to maintain optimum engine RPM. At full throttle a perfectly matched PVT system should hold engine RPM at the peak of the power curve. This RPM should be maintained during clutch upshift and backshift. In this respect, the PVT system is similar to a power governor. Rather than vary throttle position, as a conventional governor does, the PVT system changes engine load requirements by either upshifting or backshifting.

### PVT Break-In (Drive Belt / Clutches)

A proper break-in of the clutches and drive belt will ensure a longer life and better performance. Break in the clutches and drive belt by operating at slower speeds during the 10 hours as recommended (see Chapter 3 "Engine Break-In Period" for break-in example). Avoid aggressive acceleration and high speed operation during the break-in period. After installation of a new drive belt, break-in new drive belts by operating at slower speeds during the break-in period ~50 miles. Carry only light loads. Avoid aggressive acceleration, high speed operation, and extended time at a specific RPM during the break-in period. In addition, when operating in sand/dune environments, avoid extended low speed operation at high throttle.

# CLUTCHING

---

## Maintenance / Inspection

Under normal use the PVT system will provide years of trouble free operation. Periodic inspection and maintenance is required to keep the system operating at peak performance. The following list of items should be inspected and maintained to ensure maximum performance and service life of PVT components. Refer to the troubleshooting checklist at the end of this chapter for more information.

1. **Belt Inspection.**
2. **Drive and Driven Clutch Buttons and Bushings, Drive Clutch Shift Weights and Pins, Drive Clutch Spider Rollers and Roller Pins, Drive and Driven Clutch Springs.**
3. **Sheave Faces.** Clean and inspect for wear.
4. **PVT System Sealing.** Refer to the appropriate illustration (s) on the following pages. The PVT system is air cooled by fins on the drive and driven clutch stationary sheaves. The fins create a low pressure area in the crankcase casting, drawing air into the system through an intake duct. The opening for this intake duct is located at a high point on the vehicle (location varies by model). The intake duct draws fresh air through a vented cover. All connecting air ducts (as well as the inner and outer covers) must be properly sealed to ensure clean air is being used for cooling the PVT system and also to prevent water and other contaminants from entering the PVT area. This is especially critical on units subjected to frequent water foraging.

## Overheating / Diagnosis

During routine maintenance, or whenever PVT system overheating is evident, it's important to check the inlet *and* outlet duct for obstructions. Obstructions to air flow through the ducts will significantly increase PVT system operating temperatures. The vehicle should be operated in Low when extended low vehicle speed operation is anticipated.

CLUTCH DRIVE BELT & COVER RELATED ISSUES: DIAGNOSIS	
POSSIBLE CAUSES	SOLUTIONS / WHAT TO DO
Loading the vehicle into a tall trailer when in high range.	Shift transmission to Low during loading of the vehicle to prevent belt burning.
Starting out going up a steep incline from a stopped position.	When starting out on an incline, use Low gear. Shift transmission to Low during loading of the vehicle to prevent belt burning.
Driving at low RPM or low ground speed (at approximately 3-7 MPH).	Drive at higher speed or use Low. The use of Low is highly recommended for cooler PVT operating temperatures and longer component life.
Insufficient engine warm-up when exposed to low ambient temperatures.	Warm engine at least 5 min., then with transmission in neutral, advance throttle to approx. 1/8 throttle in short bursts, 5 to 7 times. The belt will become more flexible and prevent belt burning.
Slow and easy clutch engagement.	Fast, effective use of the throttle for efficient engagement.
Stuck in mud or snow.	Shift the transmission to Low, carefully use fast, aggressive throttle application to engage clutch. <b>WARNING:</b> Excessive throttle may cause loss of control and vehicle overturn.
Climbing over large objects from a stopped position.	Shift the transmission to Low, carefully use fast, aggressive, brief throttle application to engage clutch. <b>WARNING:</b> Excessive throttle may cause loss of control and vehicle overturn.
Belt slippage from water or snow ingestion into the PVT system.	Remove the PVT drain plug. Shift the transmission to neutral. Using the throttle, vary the engine rpm from idle to full throttle. Repeat several times as required. During this procedure, the throttle should not be held at the full position for more than 10 seconds. Clutch seals should be inspected for damage if repeated leaking occurs.
Clutch malfunction.	Clutch component inspection should be performed by a Polaris MSD certified technician.
Poor engine performance.	Fouled spark plugs, foreign material in fuel tank, restricted fuel lines, or faulty fuel pump may cause symptoms similar to clutching malfunction.
GENERAL RANGE OPERATION GUIDELINES:	<b>Low:</b> Basic operational speeds less than 7 MPH, riding through rough terrain (swamps, mountains, ect.), or low ground speeds and when continuously operating at speeds less than 30 mph in sand/dune environments.
	<b>High:</b> High ground speeds, or speeds above 7 MPH.

### Operating in Low Gear

Low gear should be used when riding through rough terrain or when basic operational ground speeds are less than 7 MPH. Use High gear when basic operational ground speeds are more than 7 MPH.

### General Sand / Dune Driving

The use of Low gear when continuously operating at speeds less than 30 mph will greatly increase belt life in sand/dune environments. Note: Do not shift from Low to High without coming to a complete stop.

**NOTE: Using High gear for heavy loads, hilly terrain, sand/dune environments, or in wet, muddy conditions will increase the chance of drive belt burning.**

# CLUTCHING

## PVT SYSTEM SERVICE

### PVT Covers and Duct Components

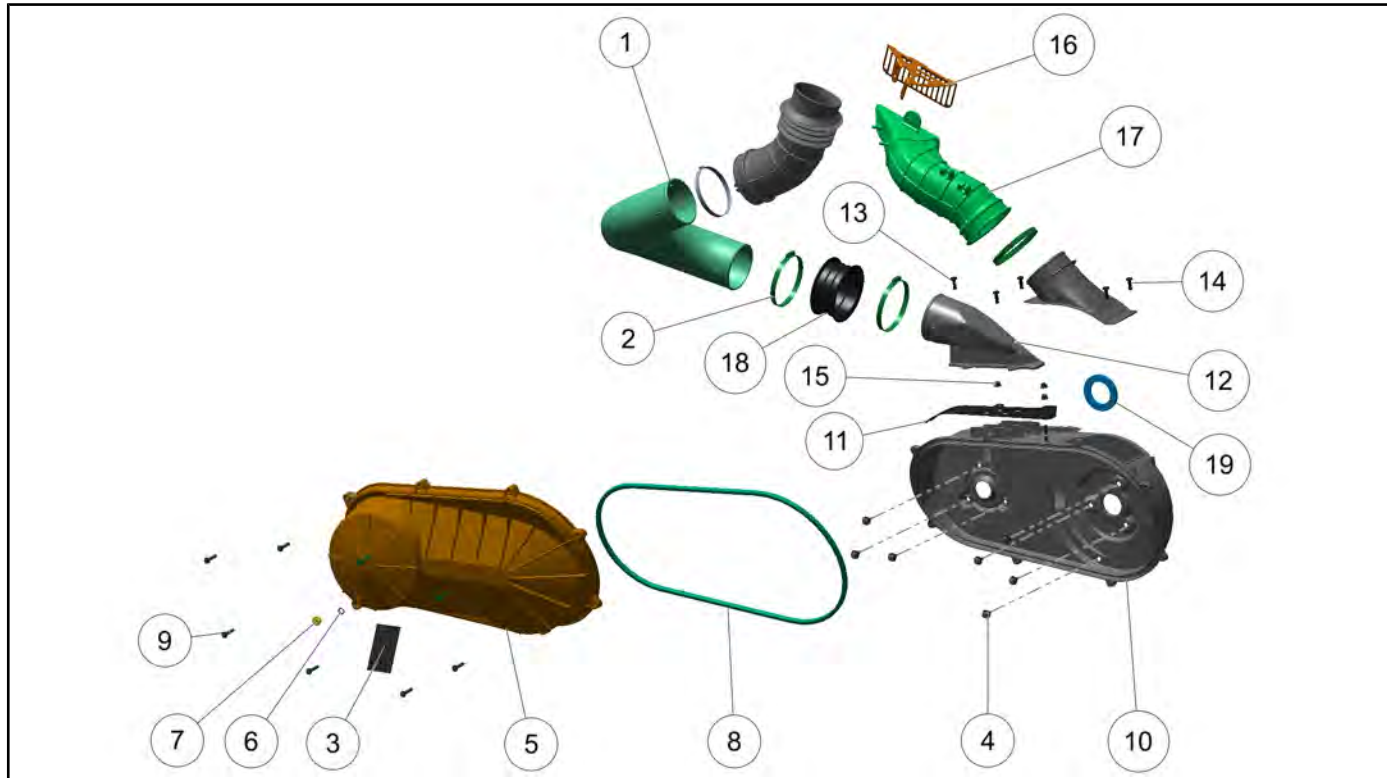

1. CLUTCH DUCT INTAKE ASSEMBLY	11. BRACKET, COVER GUARD
2. CLAMP, WORM	12. AIR INLET DUCT
3. DECAL, CAUTION	13. SCREW
4. BOLT and WASHER	14. SCREW
5. COVER ASSEMBLY, OUTER	15. NUT, NYLOK
6. O-RING	16. BRACKET, BELT SCREEN
7. DRAIN PLUG, COVER	17. HOSE, AIR OUTLET
8. SEAL, COVER	18. INTAKE BOOT
9. SCREW	19. SEAL, COVER
10. COVER ASSEMBLY	

## PVT Disassembly

### CAUTION

#### Correct Drive Clutch Puller P/N 2872085

2872085 - Correct Drive Clutch Puller For RZR XP 900

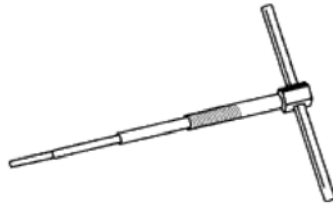

PA-48595 - Incorrect Drive Clutch Puller

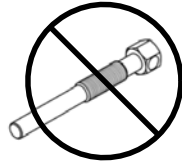

1. Place transmission in neutral.
2. Raise and support the vehicle.

### CAUTION

Serious injury may result if machine tips or falls. Be sure machine is secure before beginning this service procedure.

3. Remove the left rear wheel.
4. Remove the lower mounting bolt and nut (Item 1) from the left rear shock. Discard the nut.
5. Swing shock outward toward the front of the vehicle.
6. Remove the eight clutch cover screws (Item 2) and remove the outer clutch cover from the vehicle.

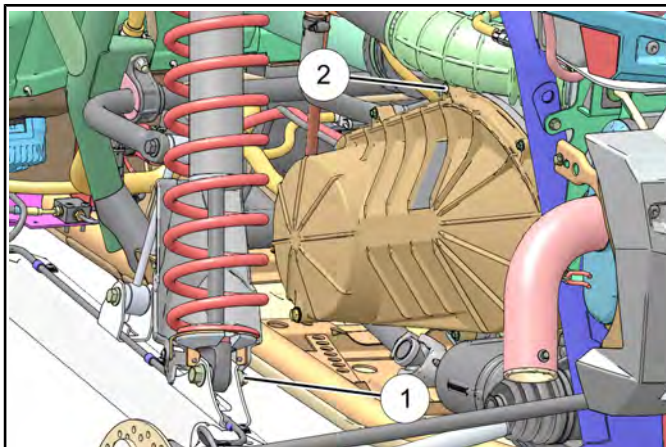

7. Mark the drive belt direction of rotation and remove drive belt (see "DRIVE BELT - Belt Removal").
8. Remove the driven clutch retaining bolt and driven clutch.
9. Install the Drive Clutch Holding Tool (9314177-A) on the drive clutch.

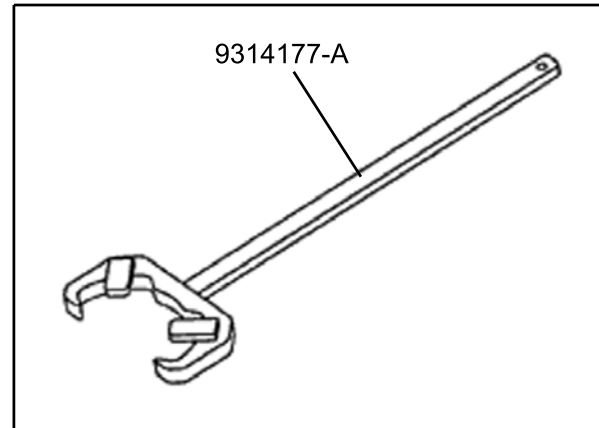

Drive Clutch Holding Tool 9314177-A

10. Remove the drive clutch retaining bolt and remove the drive clutch using Drive Clutch Puller 2872085.

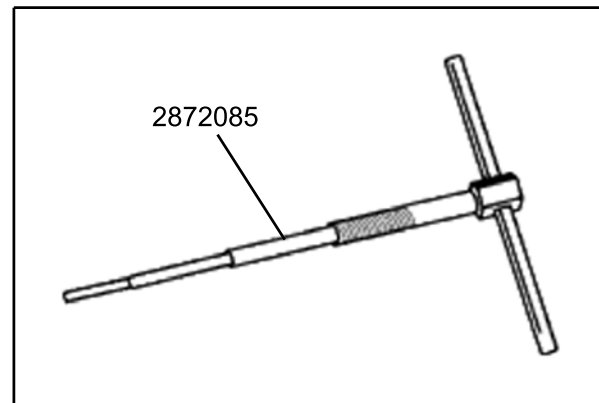

Drive Clutch Puller 2872085

**NOTE:** Be sure to use the correct Drive Clutch Puller (PN 2872085) to prevent damage to crankshaft.



# CLUTCHING

11. Remove the four push rivets that secure the upper guard plate to the top of the inner PVT cover. Make note of the routing of the fuel lines, vent line, battery cable and wire harness for proper assembly.

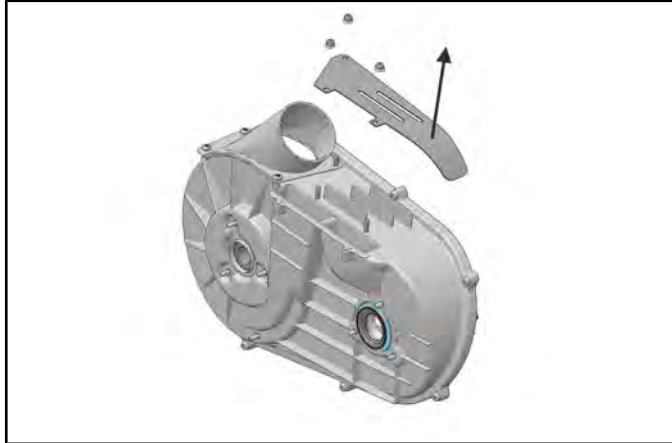

12. Loosen the hose clamp attaching PVT inlet duct to the inner clutch cover. Disengage the hose from the inner clutch cover.

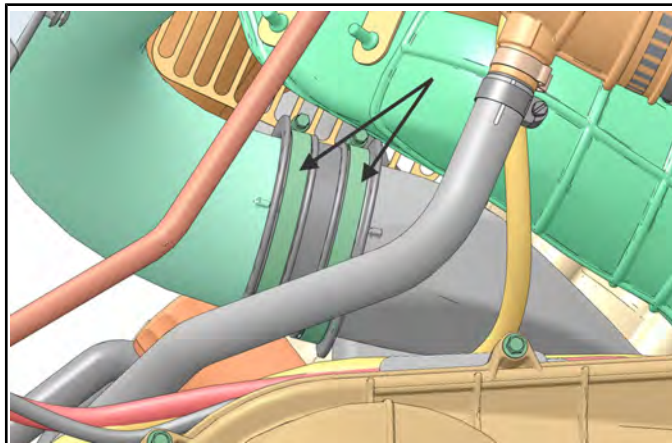

13. Loosen hose clamps (Item 3) that attach clutch outlet duct to inner clutch cover. Disengage hose from the cover.

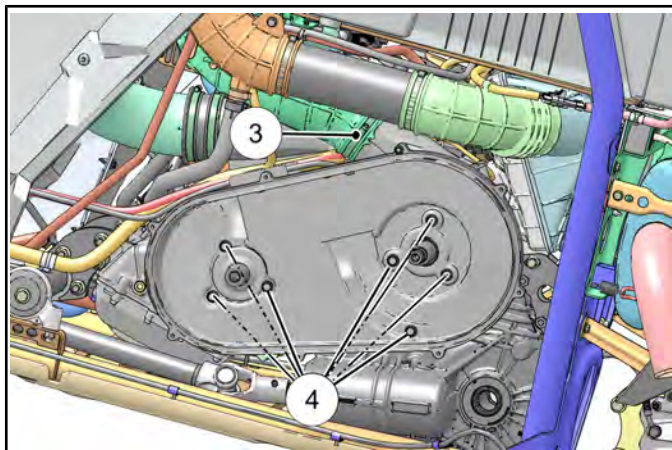

14. Remove the seven bolts (Item 4) that retain inner clutch cover to engine and transmission. Remove inner clutch cover.

## PVT Assembly

1. Inspect inner clutch cover. Replace if cracked or damaged.
2. Inspect the seal on the transmission input shaft. Replace if damaged.
3. Inspect inner clutch cover seal (engine side). Replace if cracked, torn or damaged.

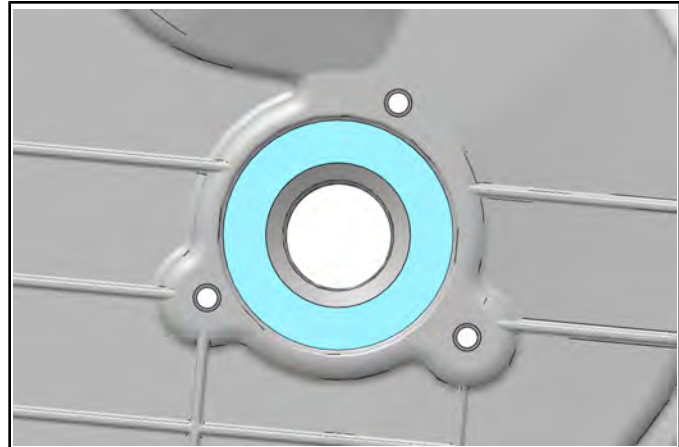

4. Install and properly align the inner clutch cover. Be sure the fuel line, vent line and battery cables are properly routed through the guard plate as shown (Item 1).

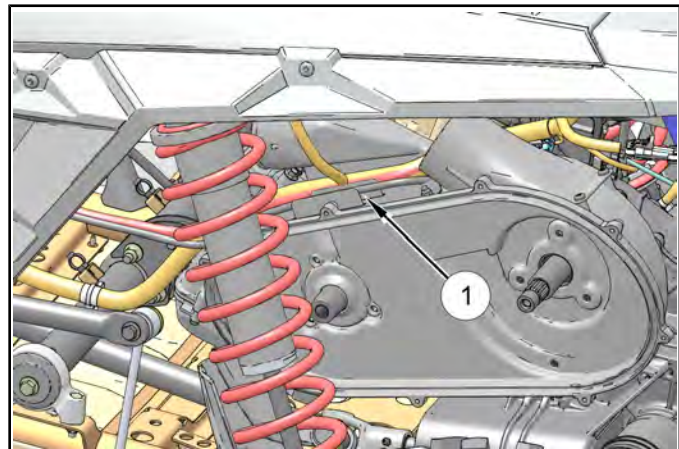

5. Install the protective cover and the four push rivets that secure the cover to the top of the inner PVT cover.



6. Install the four inner clutch cover bolts and washers that retain the cover to the transmission. Torque bolts to specification.
7. Install the three inner clutch cover bolts and washers that retain the cover to the engine. Torque bolts to specification.



Inner Clutch Cover Bolts:  
**12 ft-lb (16 Nm)**

8. Clean the splines inside the driven clutch and on the transmission input shaft.
9. Apply a light film of grease to the splines on the shaft.
10. Install the driven clutch, washer and retaining bolt. Torque to specification.



Driven Clutch Retaining Bolt:  
**55 ft-lb (75 Nm)**

11. Clean the end of the taper on the crankshaft and the tapered bore inside the drive clutch.
12. Install the drive clutch onto the engine.

13. Install the Drive Clutch Holding Tool (9314177-A) and torque the retaining bolt to specification.



Drive Clutch Retaining Bolt:  
**96 ft-lb (130 Nm)**

14. Install the drive belt noting direction of belt rotation (see "DRIVE BELT - Belt Installation"). If a new belt is installed, install so numbers can be easily read.
15. Install a new outer clutch cover seal with the colored stripe facing the inner clutch cover.
16. Reinstall outer clutch cover and secure with screws. Torque screws to specification.





Outer Clutch Cover Retaining Screws:  
**48 in-lb (5 Nm)**

17. Install inlet and outlet ducts and tighten hose clamps.

# CLUTCHING

18. Install the left rear shock lower mounting bolt and the left rear wheel. Torque fasteners to specification.

 = T
Rear Shock Mounting Bolt: 70 ft-lbs (95 Nm)

 = T
Wheel Nuts: 120 ft-lbs (163 Nm)

## DRIVE BELT

### Belt Removal

**NOTE:** Inspect the entire clutch outlet duct (including the outlet duct screen) when replacing a drive belt. Remove any debris found in the outlet duct or outlet duct screen (Item 1).

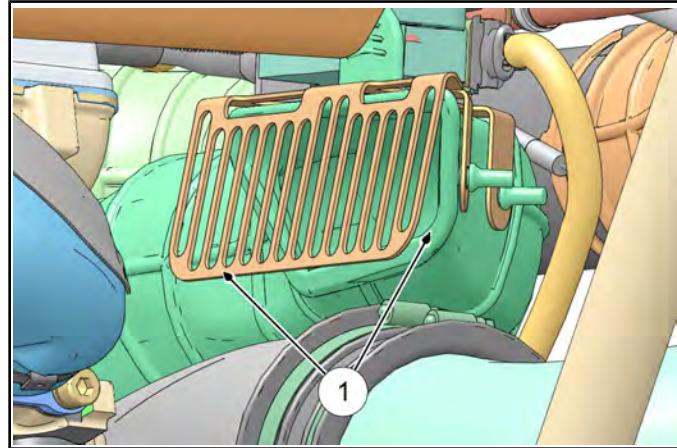

1. Remove the eight screws that retain the outer clutch cover.
2. Maneuver the outer clutch cover outward as shown below to access the drive belt.

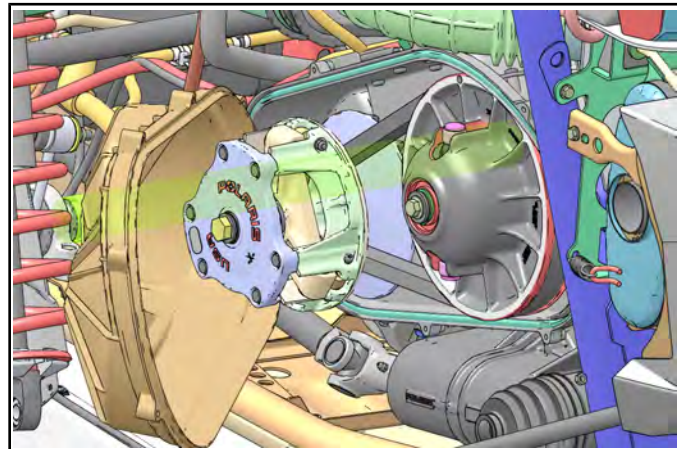

**NOTE:** Removal of left rear wheel or left rear shock is **NOT** necessary for belt replacement.

3. Mark the drive belt direction of rotation so that it can be installed in the same direction.

4. Insert clutch spreader tool (2877408 or 2878925) into the driven clutch as shown (tool included with vehicle's tool kit).

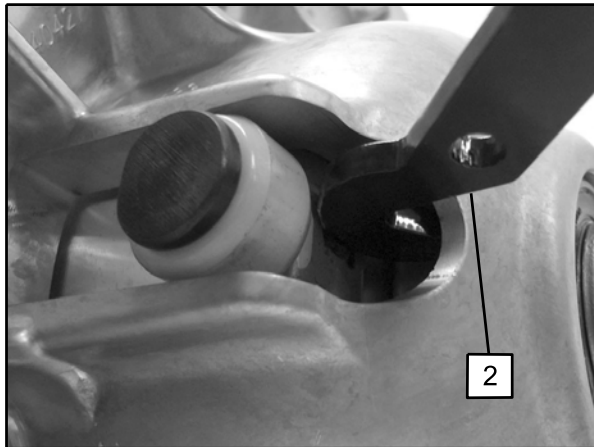

**NOTE:** Make sure the tool is square with the moveable sheave surface of the driven clutch.

5. Rotate tool towards the clutch to open the sheaves.

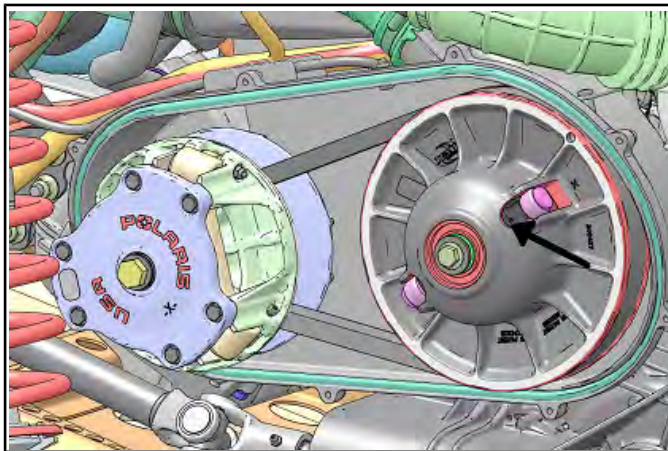

6. Walk the belt out of the driven clutch and drive clutch. Remove the belt from the vehicle.

## Belt Inspection

1. Inspect belt for hour glassing (extreme circular wear in at least one spot and on both sides of the belt). Hour glassing occurs when the drive train does not move and the drive clutch engages the belt.
2. Inspect belt for loose cords, missing cogs, cracks, abrasions, thin spots, or excessive wear. Compare belt measurements with a new drive belt. Replace if necessary.
3. Belts with thin spots, burn marks, etc., should be replaced to eliminate noise, vibration, or erratic PVT operation. See the Troubleshooting Chart at the end of this chapter for possible causes.

## Belt Installation

**NOTE:** Be sure to install belt in the same direction as it was removed.

1. With the clutch spreader tool installed (2877408 or 2878925), loop the belt over the drive clutch and over the driven clutch.

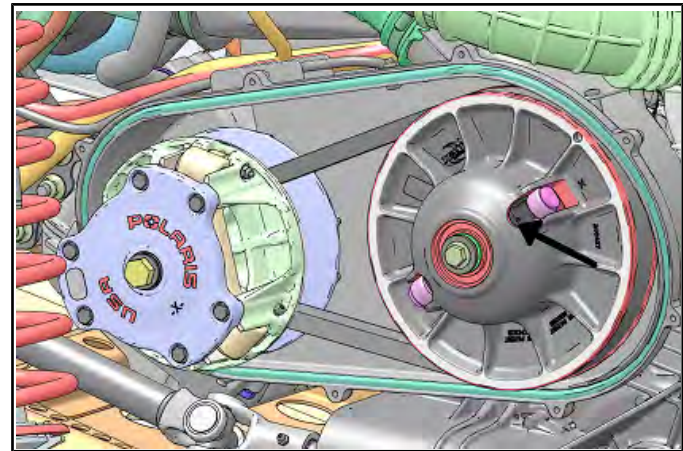

2. Rotate the driven clutch and walk the belt into the clutch.
3. Remove the clutch spreader tool from driven clutch
4. Rotate / spin the driven clutch and belt approximately 5-7 times to properly seat the belt in the driven clutch.
5. Install the outer clutch cover and eight screws. Torque screws to specification.



Outer Clutch Cover Retaining Screws:  
48 in-lb (5 Nm)

## PVT Break-In (Drive Belt / Clutches)

A proper break-in of the clutches and drive belt will ensure a longer life and better performance. Break in the clutches and drive belt by operating at slower speeds during the 10 hour break-in period as recommended (see Chapter 3 Engine Break-In Period, page 3.32 for break-in example). Pull only light loads. Avoid aggressive acceleration and high speed operation during the break-in period.

# CLUTCHING

## DRIVE CLUTCH SERVICE

### Drive Clutch Assembly View

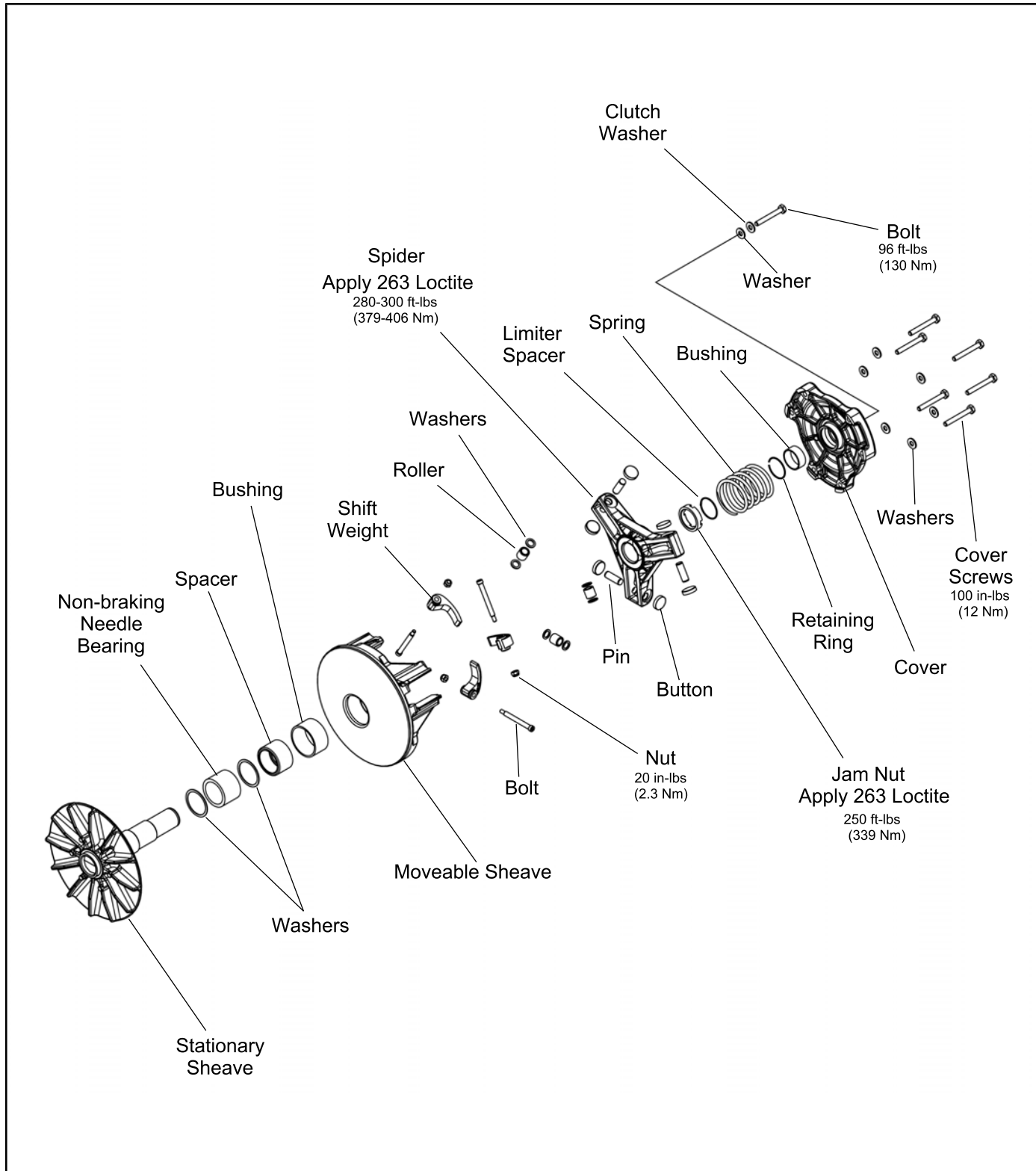

## Drive Clutch Disassembly / Inspection

### WARNING

The clutch assembly is a precisely balanced unit. Never replace parts with used parts from another clutch assembly!

- Using a permanent marker, mark the cover, spider, moveable and stationary sheaves for reference, as the cast in X's may not have been in alignment before disassembly.

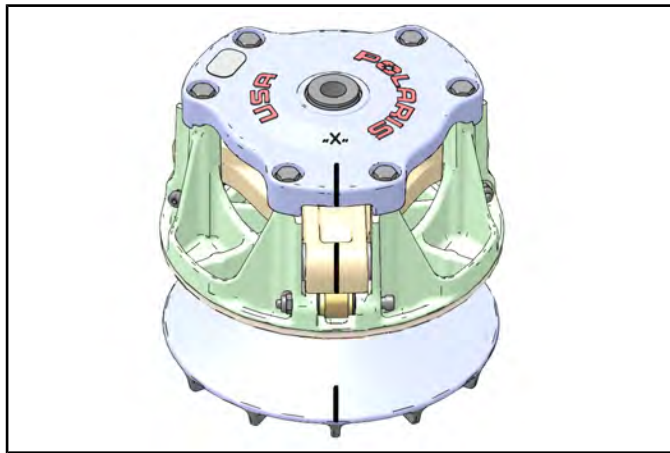

- Mark the stationary sheave and clutch shaft to verify the shaft has not rotated in the sheave after tightening the spider during clutch assembly.

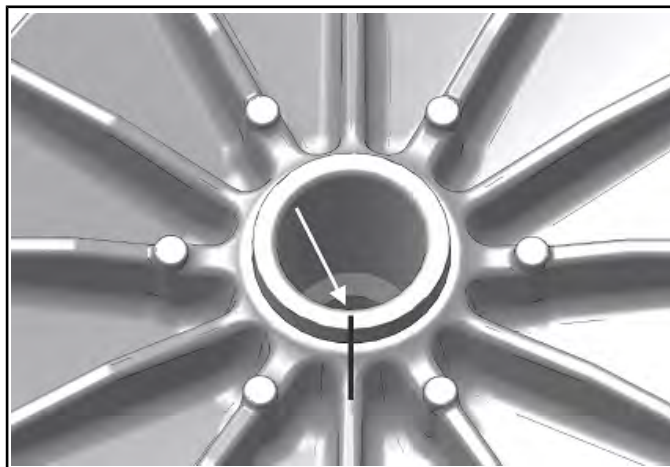

**NOTE:** Upon reassembly, if the reference marks created in step 2 are not in alignment, the clutch will not be in balance and the assembly **MUST** be replaced.

- Remove cover bolts evenly in a cross pattern and remove cover plate.

- Inspect cover bushing (Item 1). The outer cover bushing is manufactured with a Teflon™ coating. Wear is determined by the amount of Teflon™ remaining on the bushing.

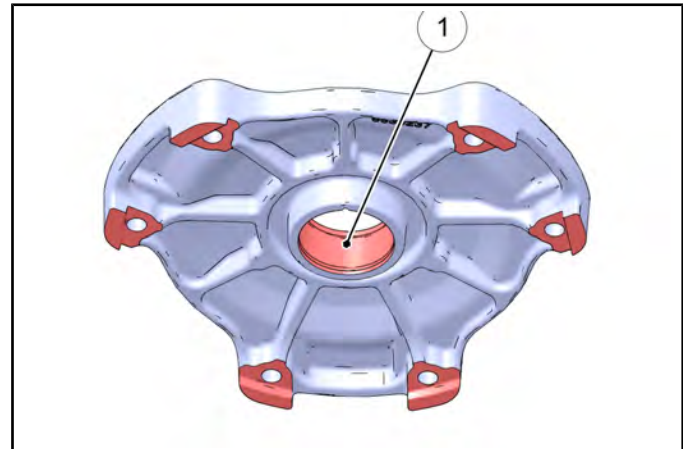

**Cover Bushing Inspection:**  
Replace the cover bushing if more brass than Teflon™ is visible on the bushing. Refer to bushing replacement in this chapter.

- Inspect area on shaft where bushing rides for wear, galling, nicks, or scratches. Replace clutch assembly if worn or damaged.
- Remove and inspect the clutch spring (Item 2). Refer to "Drive Clutch Spring Inspection".

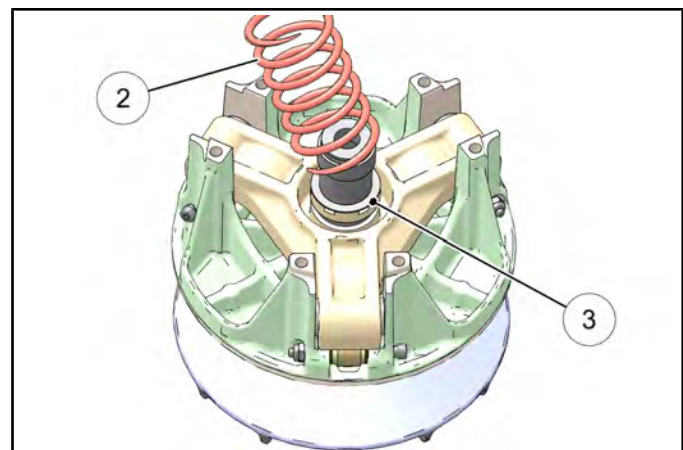

- Remove and inspect limiter spacer (s) (Item 3). Replace if necessary.

### CAUTION

DO NOT reassemble the drive clutch without the limiter spacer. Belt life will be greatly reduced.

### Drive Clutch Spring Inspection

# CLUTCHING

## CAUTION

Never shim a drive clutch spring to increase its compression rate. This may result in complete stacking of the coils and subsequent clutch cover failure.

The drive clutch spring is one of the most critical components of the PVT system. It is also one of the easiest to service. Due to the severe relaxation the spring is subject to during operation, it should always be inspected for tolerance limits during any clutch operation diagnosis or repair.

Check to see that spring coils are parallel to one another using a straight-edge. Distortion of the spring indicates stress fatigue, requiring replacement.

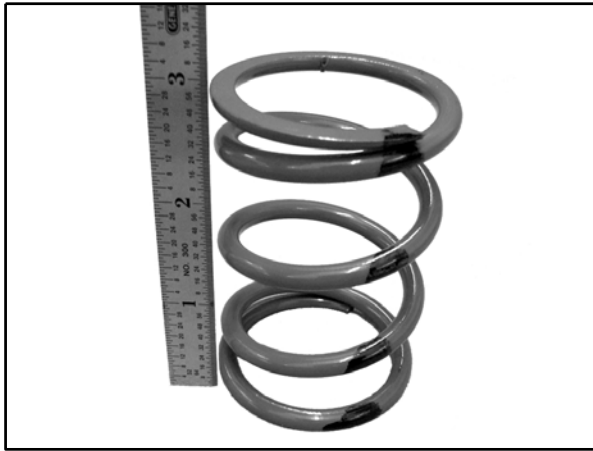

### Drive Clutch Spring Specifications

Part Number	7043924
Color	White / Orange
Free Length	3.563" (90.50 mm)
Spring Wire Diameter	0.177" (4.50 mm)

### Needle Bearing Inspection

1. Rotate the clutch bearing in both clockwise and counter-clockwise directions. The non-braking needle bearing should rotate in both directions on the shaft with only a slight amount of drag.

2. Verify there is no binding or rough spots. If problems are noted continue with disassembly.

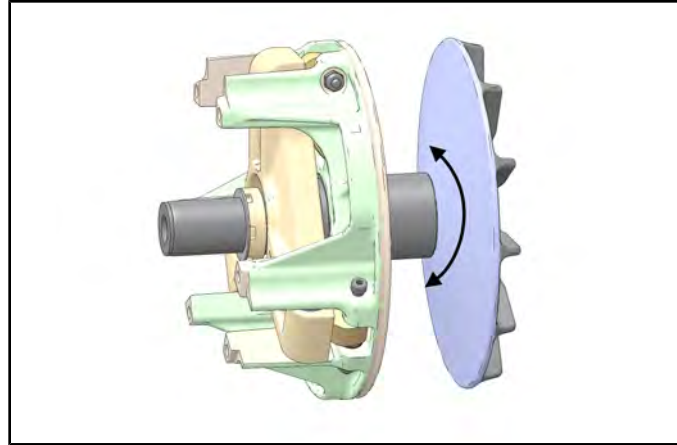

### Shift Weight Inspection

1. Remove shift weight bolts and weights. Inspect the contact surface of each weight. The surface should be smooth and free of dents or gall marks. Inspect the weight pivot bore and bolts for wear or galling. If weights or bolts are worn or broken, replace in sets of three with new bolts and nuts.

## WARNING

The clutch assembly is a precisely balanced unit. Never replace parts with used parts from another clutch assembly!

**NOTE:** A damaged shift weight is usually caused by a damaged or stuck roller in the spider assembly. See "Drive Clutch Roller Pin and Button Service".

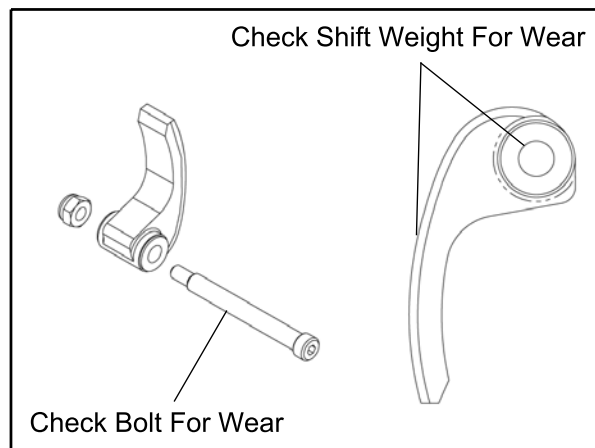

## Button To Tower Clearance Inspection

1. Inspect the button to tower clearance as shown. Replace the drive clutch if clearance is beyond specification.

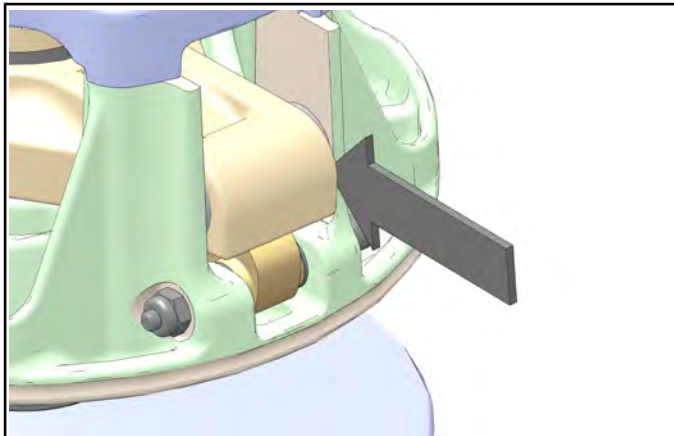

**Button to Tower Clearance:**  
0.000-.012" (.000-.304 mm)

2. Inspect the tower sheave surfaces. Replace the drive clutch if worn, damaged or cracked.

## Spider Removal

1. Install clutch onto holding fixture (2871358-A) and secure in bench vice. Loosen and remove the spider jam nut (counterclockwise) using the Clutch Spider Nut Socket (PU-50578).

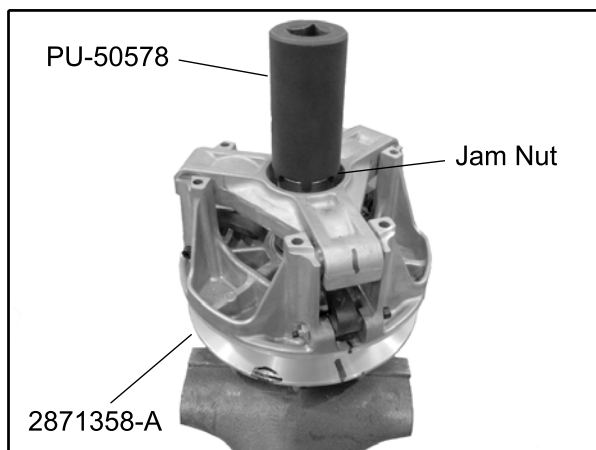

**Clutch Spider Nut Socket: PU-50578**  
**Clutch Holding Fixture: PN 2871358-A**

2. Loosen and remove the spider (counterclockwise) using Clutch Spider Removal / Installation Tool (PN 2870341).

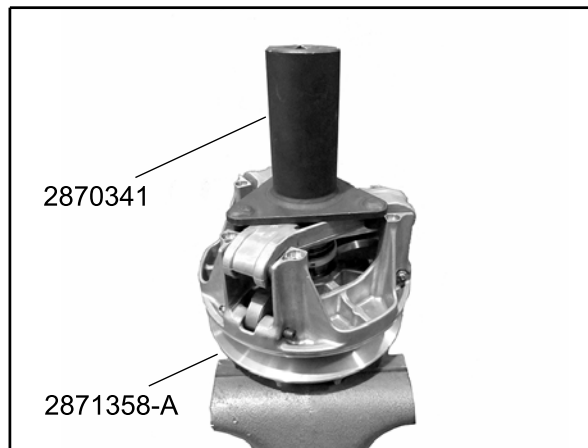

**Spider Removal / Installation Tool: 2870341**  
**Clutch Holding Fixture: 2871358-A**

6

## Roller, Pin, and Thrust Washer Inspection

1. Inspect all rollers, roller bushings and roller pins by pulling a flat metal rod across the roller.
2. Turn roller with your finger. If you notice resistance, galling, or flat spots, replace the drive clutch.

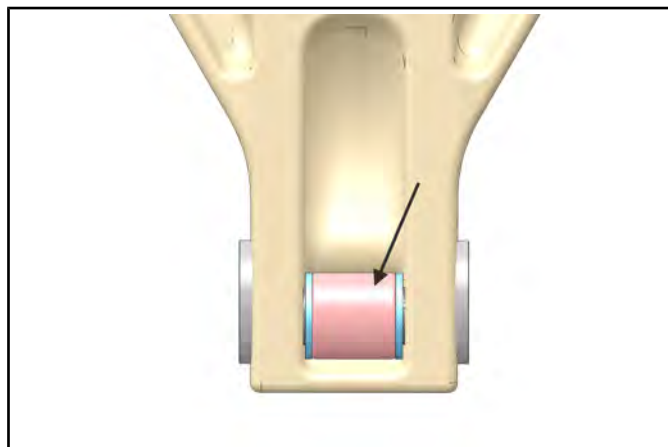

**NOTE: Rollers, pins, thrust washers and buttons are not serviceable at the time of this publication.**



# CLUTCHING

## Clutch Inspection

**NOTE: Remove cover, spring, limiter spacer and spider following the instructions for drive clutch disassembly, then proceed as follows:**

1. Remove and inspect the moveable sheave spacer (Item 1). Visually inspect the spacer for damage and replace if necessary.

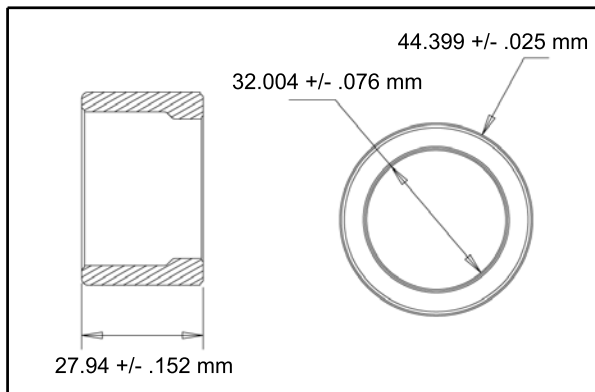
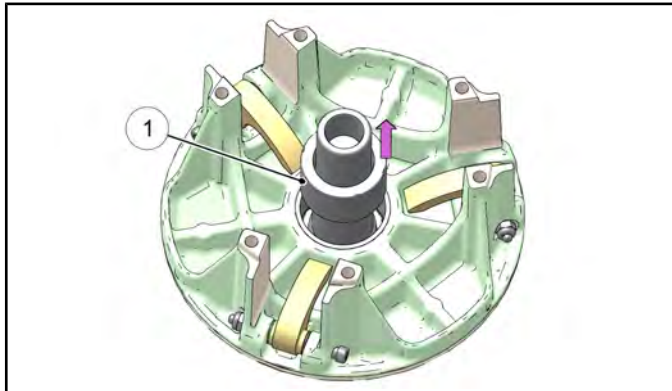

2. Remove the moveable clutch sheave.
3. Lift bearing (Item 3) and thrust washers (Item 2) off the shaft. Replace as an assembly if worn, damaged, or if operational problems were noted prior to disassembly.

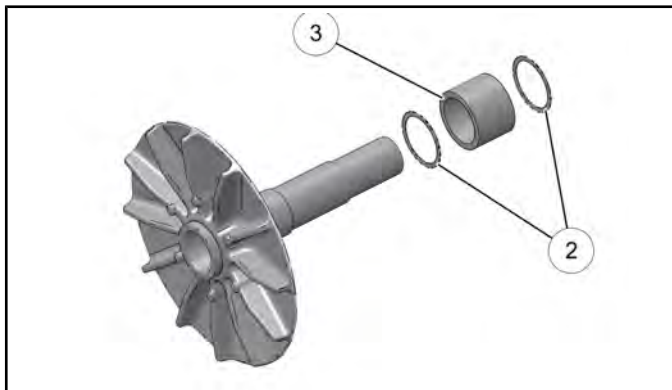

4. Inspect surface of shaft for pitting, grooves or damage. Measure the outside diameter and compare to specifications. Replace the drive clutch assembly if shaft is worn or damaged.

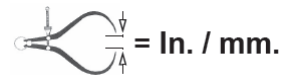
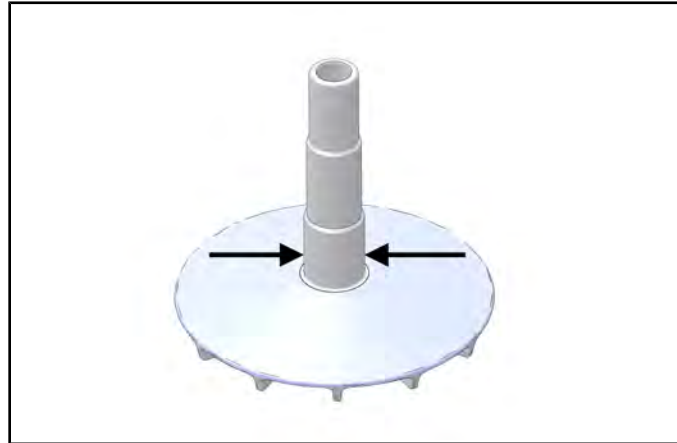

Shaft Diameter:  
 Standard: 1.3725 - 1.3712"  
 (34.8615 - 34.8488 mm)  
**Service Limit: 1.3704" (34.8088 mm)**

5. Visually inspect the thrust washers for damage. Measure the thickness and compare to specification. Replace if worn or damaged.

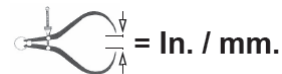

Thrust Washer Thickness:  
**Standard: .030" (.76 mm)**  
**Service Limit: .025" (.64 mm)**

## Moveable Sheave Bushing Inspection

Inspect the Teflon™ coating (arrow) on the moveable sheave bushing. Inspect both sheaves for signs of wear, grooving or cracking. De-glaze sheave surfaces with a 3M™ Scotch-Brite Pad if needed.

**Moveable Sheave Bushing Inspection:**  
 Replace the cover bushing if more brass than Teflon™ is visible on the bushing. Refer to bushing replacement in this chapter.

# CLUTCHING

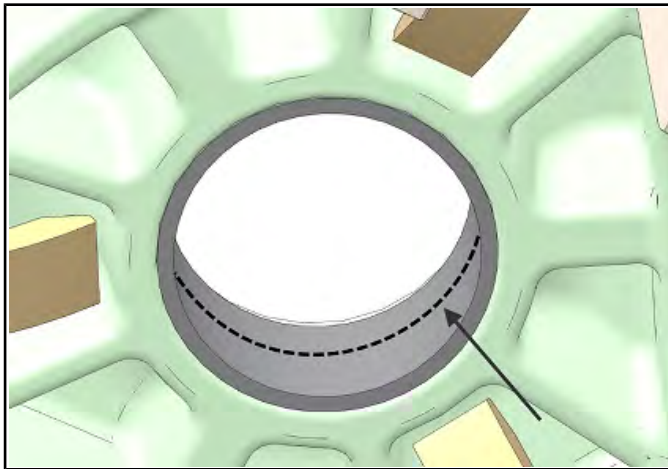

## Bushing Service

**NOTE: Special Tools Required**

### EBS Clutch Bushing Tool Kit - 2201379

ITEM	QTY.	PART #	TOOL DESCRIPTION
A, B	1	5132027	EBS Puller Tool
C	1	5132501	EBS Puller Nut
D	1	5132029	EBS Main Adapter
E	1	5132028	EBS Bushing Removal Tool Instructions
-	1	9915111	Instructions

### Additional Special Tools

QTY.	PART #	TOOL DESCRIPTION
1	2871226	Clutch Bushing Replacement Tool Kit
1	2870386	Piston Pin Puller

### \*Clutch Bushing Replacement Tool Kit (PN 2871226)

ITEM	QTY.	PART #	TOOL DESCRIPTION
#2	1	5020628	P-90 Drive/Driven Clutch Bushing Install Tool
#3	1	5020629	Drive Clutch Cover Bushing Removal /Installation Tool
#5	1	5020631	P-90 Driven Clutch Cover Bushing Removal Tool
#8	1	5020632	Main Puller Adapter

ITEM	QTY.	PART #	TOOL DESCRIPTION
#9	1	5010279	Adapter Reducer
#10	1	5020633	Number Two Puller Adapter

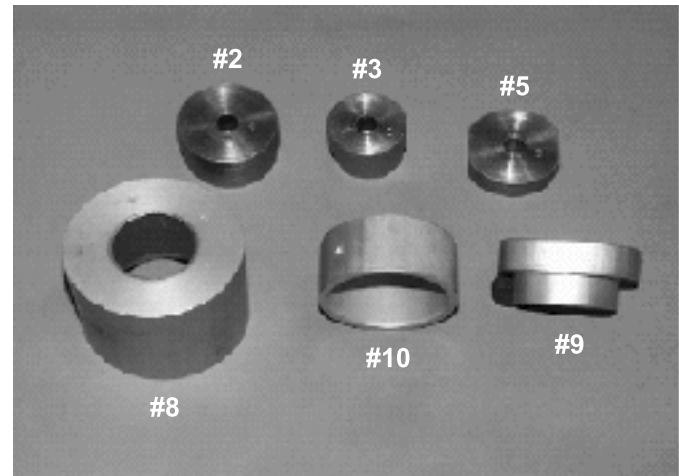

**NOTE: Bushings are installed at the factory using Loctite® 648. In order to remove bushings it will be necessary to apply heat evenly to the area around each bushing. Clean all residual Loctite® from bushing bore prior to installing new bushing.**

## CAUTION

Clutch components will be hot! In order to avoid serious burns, wear insulated gloves during the removal process.

### Moveable Sheave - Bushing Removal

1. Remove clutch as outlined previously in this chapter.

6

# CLUTCHING

2. Install handle end of the Piston Pin Puller (PN 2870386) securely into bench vise and lightly grease puller threads.

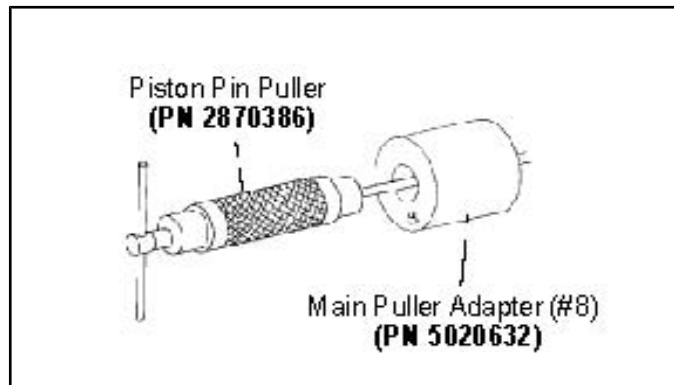

**Piston Pin Puller: PN 2870386**

3. Remove nut from puller rod and set aside.
4. Install puller adapter (Item 10) from kit PN 2871226.
5. Install main adapter (Item D) onto puller.

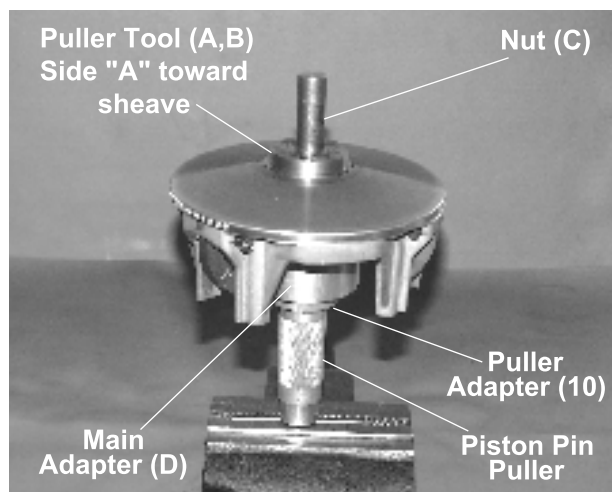

6. With towers pointing toward the vise, slide sheave onto puller rod.
7. Install removal tool (Item A, B) into center of sheave with "A side" toward sheave.

**NOTE: Use Bushing Tool PA-47336.**

8. Install nut (C) onto end of puller rod and hand tighten. Turn puller barrel to increase tension on sheave if needed. Using a hand held propane torch, apply heat around outside of bushing until tiny smoke tailings appear.
9. Turn sheave counterclockwise on puller rod until it comes free. Lift sheave off puller.
10. Remove nut from puller rod and set aside.

11. Pull bushing removal tool and adapter from puller rod. Remove bushing from tool and discard.

## Moveable Sheave - Bushing Installation

12. Place main adapter (Item 8) on puller.

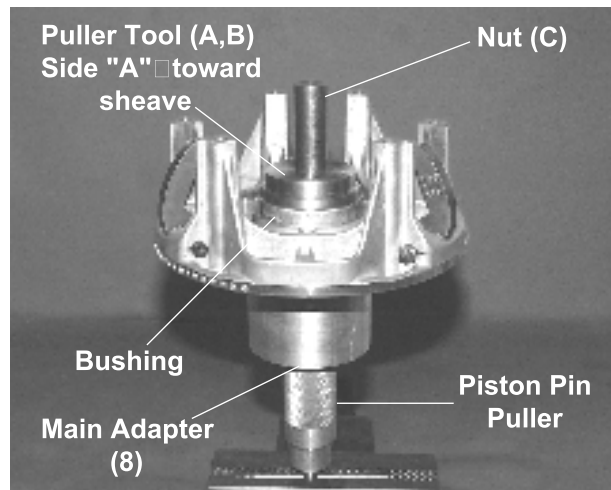

13. Apply Loctite® 648 evenly to bushing bore inside moveable sheave.
14. Set bushing in place on sheave.
15. Insert installation puller tool (Item A/B) with "A" side down, into center of bushing.
16. With towers pointing upward, slide sheave, bushing and tool onto puller rod.
17. Install nut on puller rod and hand tighten. Turn barrel to apply additional tension if needed.
18. Turn sheave counterclockwise, making sure bushing is drawn straight into bore. Continue until bushing is seated.
19. Remove nut from puller rod and set aside.
20. Remove sheave from puller.
21. Remove installation tool.

## Cover Bushing Removal

22. Install main adapter (Item 8) on puller.

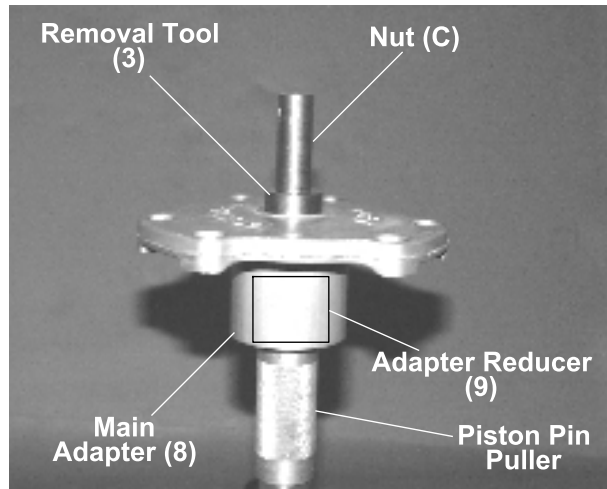

23. Install adapter reducer (Item 9).  
 24. From outside of clutch cover, insert removal tool (Item 3) into cover bushing.  
 25. With inside of cover toward vise, slide cover onto puller.  
 26. Install nut onto puller rod and hand tighten. Turn puller barrel to increase tension as needed.  
 27. Turn clutch cover counterclockwise on puller rod until bushing is removed and cover comes free.  
 28. Remove nut from puller rod and set aside.  
 29. Remove bushing and bushing removal tool from puller. Discard bushing.

### Cover Bushing Installation

30. Apply Loctite® 648 evenly to bushing bore in the cover.  
 31. Working from inside of cover, insert new bushing and bushing installation tool into center of clutch cover.  
 32. With main adapter on puller, insert cover onto puller rod, placing outside of cover toward vise.  
 33. Install nut on rod and hand tighten. Turn puller barrel to apply more tension if needed.  
 34. Turn clutch cover counterclockwise on puller rod until bushing is seated.  
 35. Remove nut from puller rod. Take installation tool and clutch cover off rod.

## Drive Clutch Assembly

### CAUTION

Do not apply oil or grease to the bushings.

Reassemble the drive clutch in the following sequence. Be sure marks that were made during disassembly are aligned during each phase of assembly.

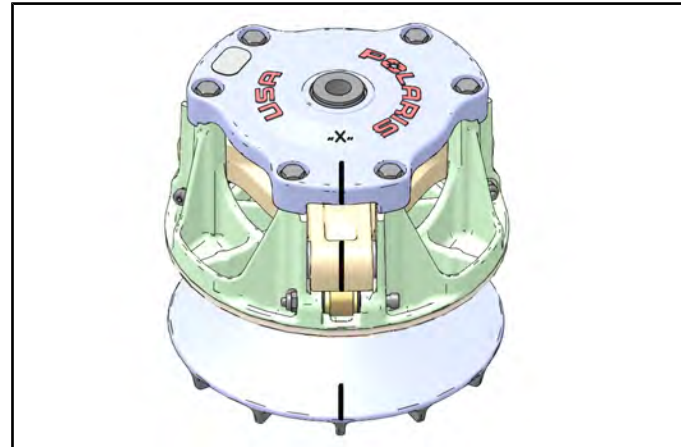

1. Install the shift weights, bolts and nuts onto the moveable sheave. Torque shift weight bolts to specification.



Shift Weight Fasteners:  
**20 in-lb (2 Nm)**

2. Install the non-braking needle bearing (Item 1), the (2) washers (Item 2) and the spacer (Item 4) onto the stationary sheave (Item 3).

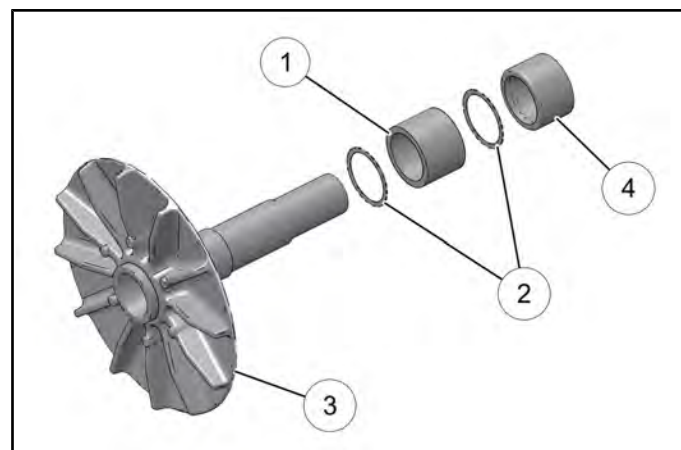

# CLUTCHING

3. Install moveable sheave onto stationary sheave shaft. Be sure the moveable sheave slides freely on the spacer.
4. Apply 0.4 mL of Loctite® 620™ and 0.4 mL of Loctite® 7088™ Primer in 90° apart in vertical stripes to the shaft threads.
5. Install the spider assembly onto the shaft threads. Be sure all of the alignment marks (Item 8) are in alignment.

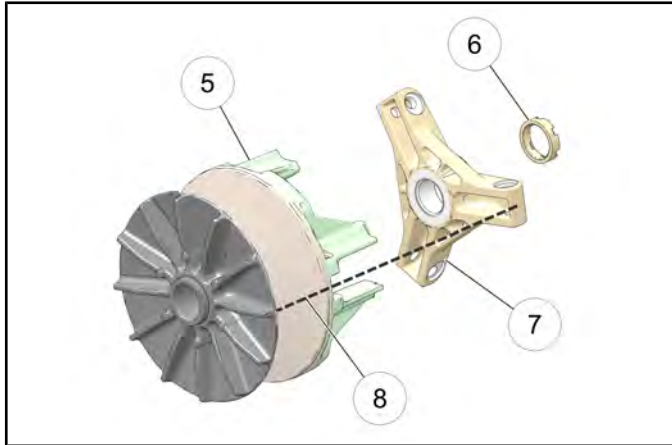

5. Moveable Sheave Asm	6. Jam Nut	7. Spider
------------------------	------------	-----------

6. Install clutch onto holding fixture (PN 2871358-A) and secure in a bench vice. Tighten the spider using Clutch Spider Tool (PN 2870341). Torque spider to specification.

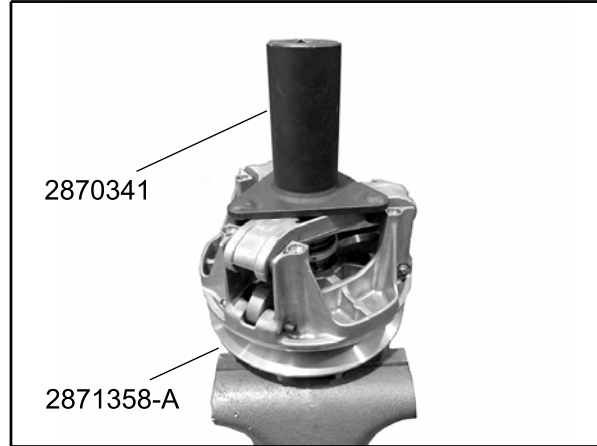

Spider Assembly:  
**290 ft-lb (393 Nm)**  
 (Apply 0.4 mL Loctite® 7088 Primer and 0.4 mL Loctite® 620™) in 90° apart in vertical stripes to the shaft threads.

7. Apply 0.1mL of Loctite® 620™ and 0.1mL of Loctite® 7088™ Primer in 90° apart to the threads of the spider jamb nut. Install spider jamb nut onto stationary shaft threads.

# CLUTCHING

8. Tighten the spider jamb nut using Clutch Spider Nut Socket (PU-50578). Torque jam nut to specification.

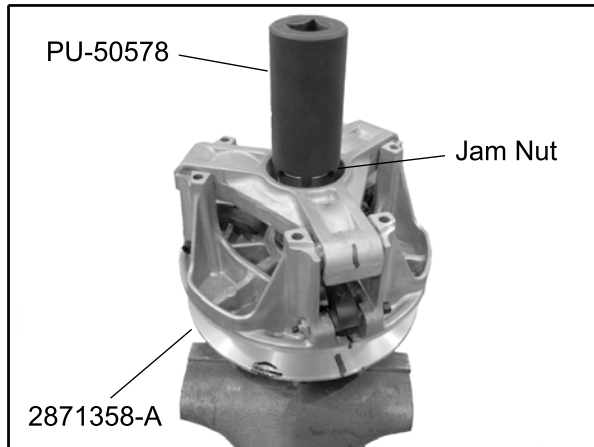

10. Install the limiter spacer (Item 15) and the clutch spring (Item 14).

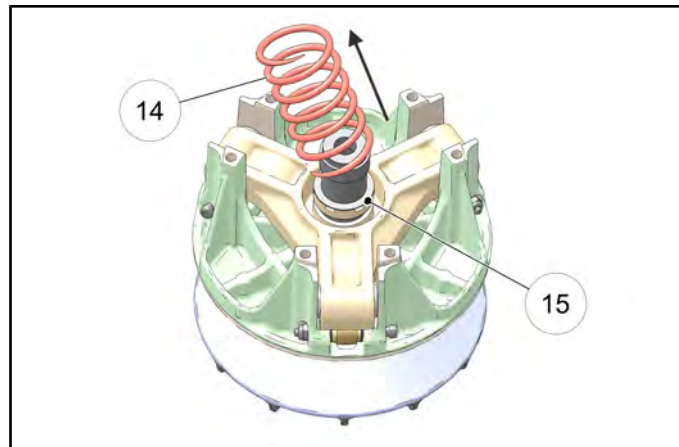

 = T

Spider Jamb Nut:  
**250 ft-lb (339 Nm)**  
 (Apply 0.1 mL Loctite® 7088 Primer and 0.1 mL Loctite® 620™) in 90° apart to the threads of the spider jamb nut.

**CAUTION**

DO NOT reassemble the drive clutch without the limiter spacer. Belt life will be greatly reduced.

9. After the spider and jamb nut have been torqued, remove the clutch assembly from the holding fixture and inspect the alignment marks made during disassembly.

**NOTE:** If the marks illustrated below are not in alignment upon assembly, the clutch will not be in balance and the drive clutch assembly must be replaced.

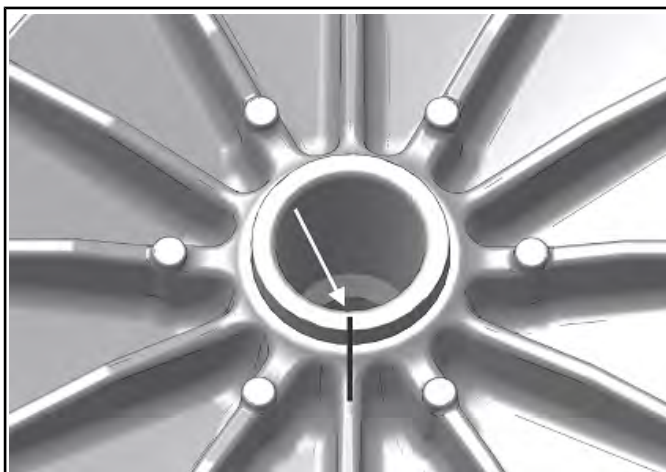

11. Install the drive clutch cover (Item 16). Be sure all alignment marks are in alignment.

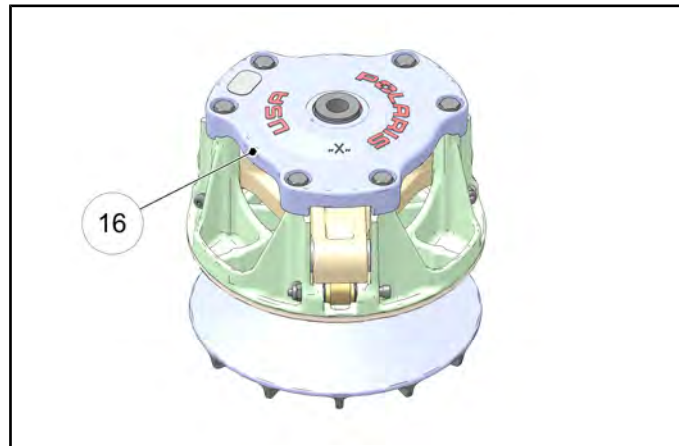

12. Install cover bolts and torque in a cross pattern evenly to specification.

 = T

Drive Clutch Cover Bolts:  
**9 ft-lb (12 Nm)**

6

# CLUTCHING

## DRIVEN CLUTCH SERVICE

### Clutch Disassembly

1. Remove driven clutch from the transmission input shaft. NOTE: If driven clutch is difficult to remove, use 2871056 Driven clutch puller to remove driven clutch. Do not attempt disassembly of the driven clutch from the outside snap ring. The driven clutch must be disassembled from the helix side.



2. It is important to mark the position of the shaft, cam cover and sheave before disassembly or use the X's on the components for reference. This will aid in assembly and maintains clutch balance.

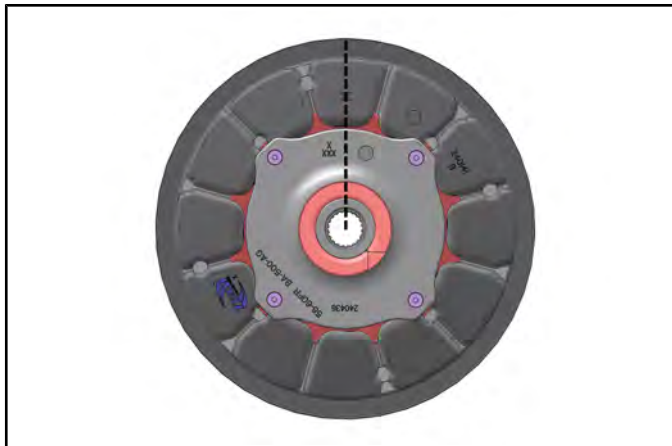

3. Remove the four screws (Item 1) that secure the cam (helix) assembly using a T25 Torx driver.

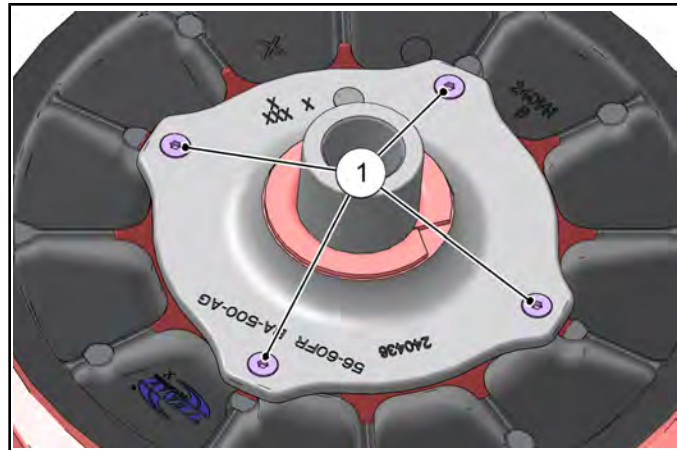

4. Place the driven clutch into the Universal Clutch Compressor **PU-50518**.

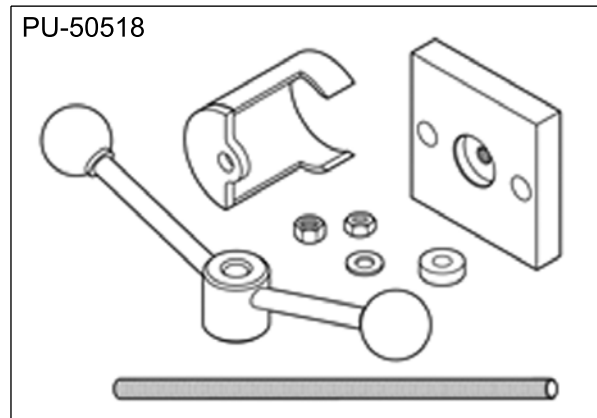

## CLUTCHING

5. Press down on the top of the spider assembly, pushing the spider onto the shaft. Remove snap ring (A) and slowly release the assembly.

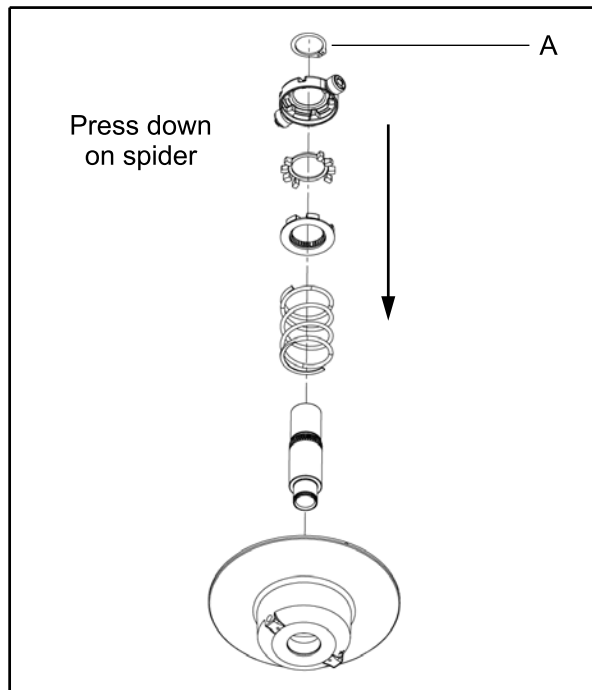

6. Remove the spider assembly and spring (B).

**NOTE: Spring is compression only and has no torsional wind.**

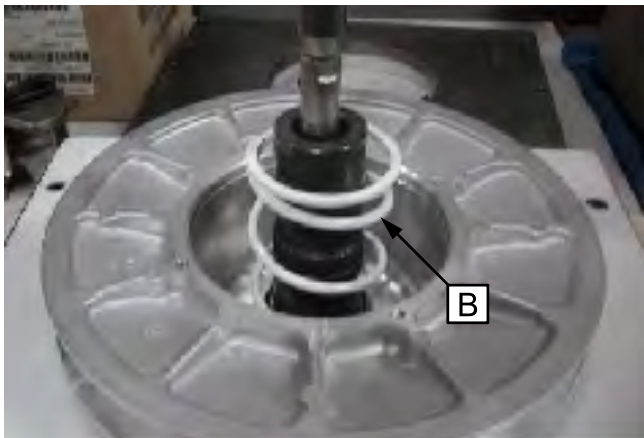

7. Remove the inside spider plate (D) and spider dampener (E). Inspect the spider dampener (E) for wear and replace if needed.

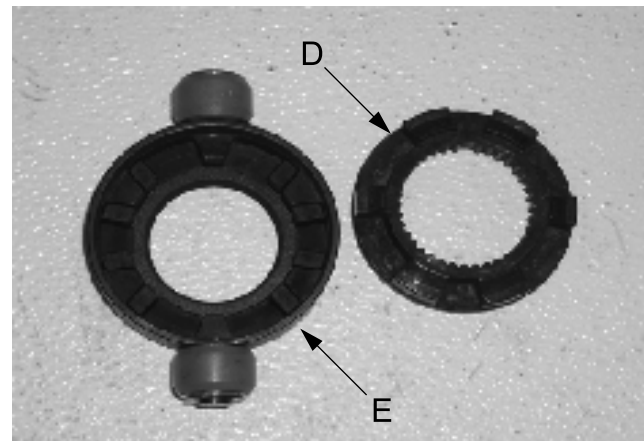

8. Remove the E-clips (F), washers (G), and the clutch rollers (H). Inspect the rollers for wear; replace if worn.

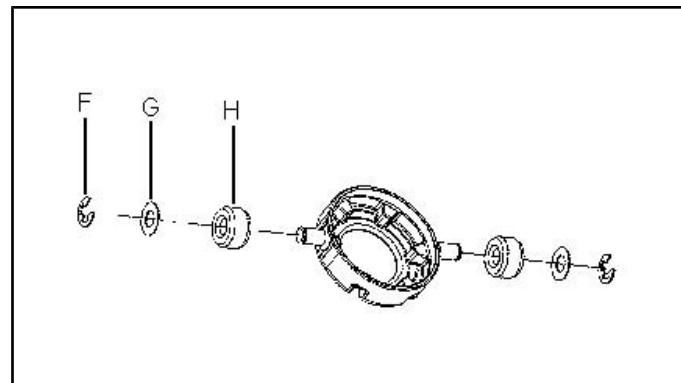

9. Remove the clutch assembly from the holding tool.
10. Press out the spring pins (I) in the inner sheave.

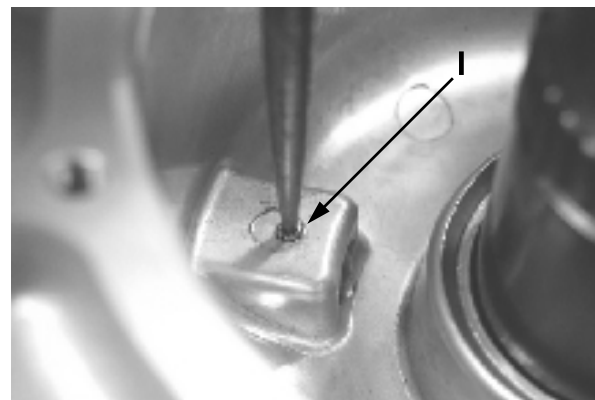

6

6.23



# CLUTCHING

11. Pull out the clutch roller pins (J) and rollers (K).

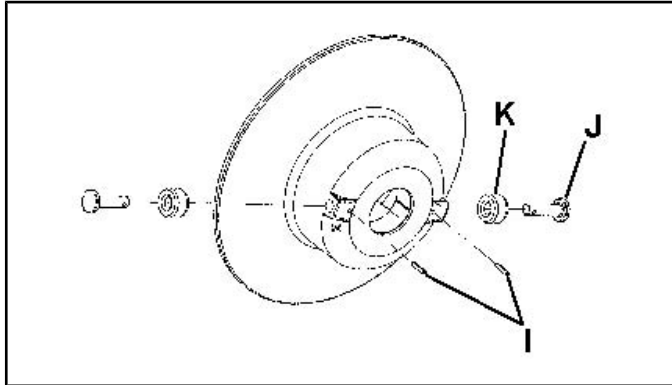

12. Press the shaft and bearing out of the outer sheave using an arbor press.

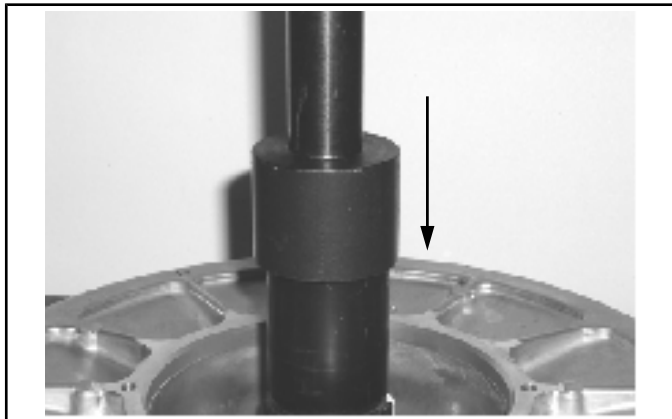

13. Inspect the bearing for wear. Spin the bearing, if the bearing does not spin smoothly, replace it. To replace the bearing, remove the snap ring from the end of the shaft and press the bearing off the shaft.

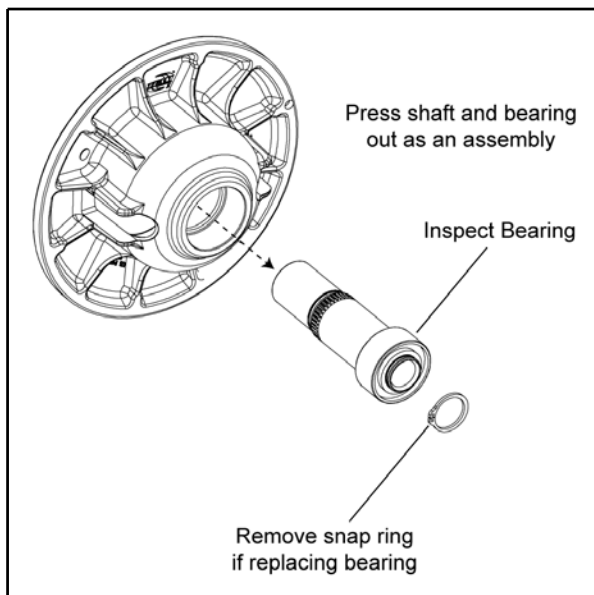

14. Inspect the cam (helix) assembly bushing for wear. If the bushing is worn or the shaft does not fit snug into the bushing, replace the cam (helix) assembly.

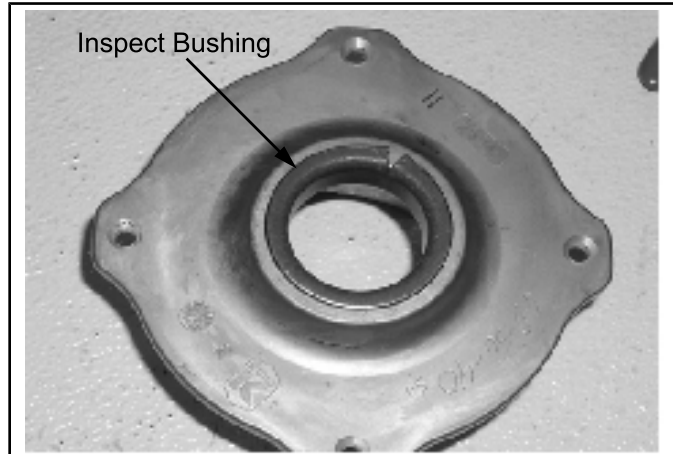

15. Inspect the sheaves for excessive wear or damage.

## Bushing Service

**NOTE: Special Tools Required**

### EBS Clutch Bushing Tool Kit - 2201379

ITEM	QTY.	PART #	TOOL DESCRIPTION
A, B	1	5132027	EBS Puller Tool
C	1	5132501	EBS Puller Nut
D	1	5132029	EBS Main Adapter
E	1	5132028	EBS Bushing Removal Tool Instructions
-	1	9915111	Instructions

### Additional Special Tools

QTY.	PART #	TOOL DESCRIPTION
1	2871226	Clutch Bushing Replacement Tool Kit
1	2870386	Piston Pin Puller

### \*Clutch Bushing Replacement Tool Kit (PN 2871226)

ITEM	QTY.	PART #	TOOL DESCRIPTION
#2	1	5020628	P-90 Drive/Driven Clutch Bushing Install Tool
#3	1	5020629	Drive Clutch Cover Bushing Removal/Installation Tool

ITEM	QTY.	PART #	TOOL DESCRIPTION
#5	1	5020631	P-90 Driven Clutch Cover Bushing Removal Tool
#8	1	5020632	Main Puller Adapter
#9	1	5010279	Adapter Reducer
#10	1	5020633	Number Two Puller Adapter

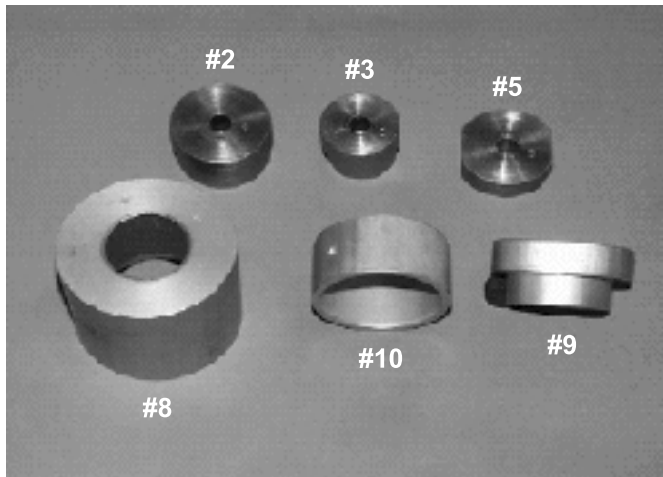

**NOTE:** Bushings are installed at the factory using Loctite® 648. In order to remove bushings it will be necessary to apply heat evenly to the area around each bushing. Clean all residual Loctite® from bushing bore prior to installing new bushing.

### Clutch Bushing Removal

1. Install main puller adapter (Item 8) onto puller.
2. Install adapter reducer (Item 9).
3. Using a hand held propane torch, apply heat around outside of bushing until tiny smoke tailings appear.
4. Flip sheave over so bushing faces downward and install onto puller.

5. Install bushing tool (Item 2).

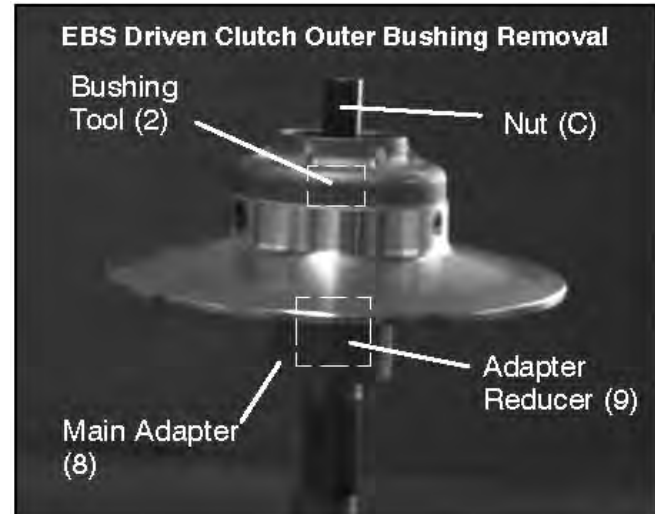

6. Install left hand nut (C) and spacer onto puller rod and tighten by hand. Turn puller barrel for further tension if needed.
7. Turn clutch sheave counterclockwise until bushing is removed and sheave comes free.
8. Remove nut (C) (left hand thread) from puller rod and set aside.
9. Remove adapters from puller.
10. Remove bushing and removal tool from adapters. Discard bushing.

### Clutch Bushing Installation

11. Install puller adapter (Item 10) onto puller.
12. Install adapter (Item 9) onto puller.

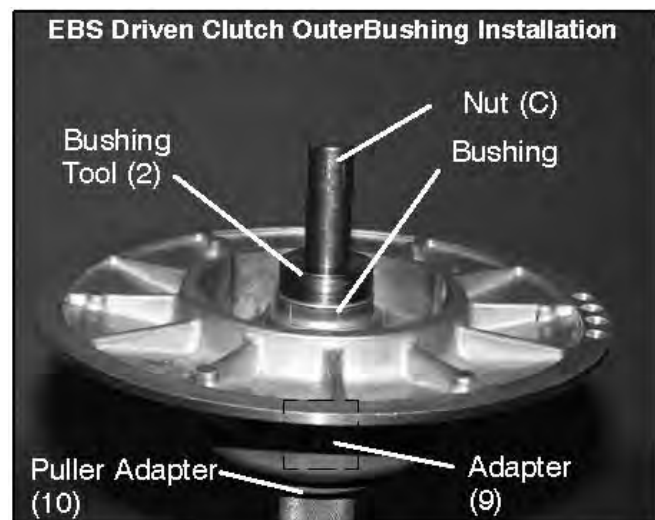

13. Apply Loctite® 648 evenly to bushing bore inside moveable sheave.

6

## CLUTCHING

---

14. Install sheave face down on puller.
15. Install new bushing on installation tool (Item 2) and install assembly into sheave.
16. Install left hand thread nut (C) onto puller rod and hand tighten against installation tool.
17. Turn clutch sheave counterclockwise, making sure bushing is drawn straight into bore. Continue until bushing is seated.
18. Remove nut (C) from puller rod and set aside.
19. Remove installation tool and clutch sheave from puller.

### Clutch Assembly

1. Install a new bearing onto the clutch shaft using an arbor press. Once bearing is fully seated, install a new snap ring.

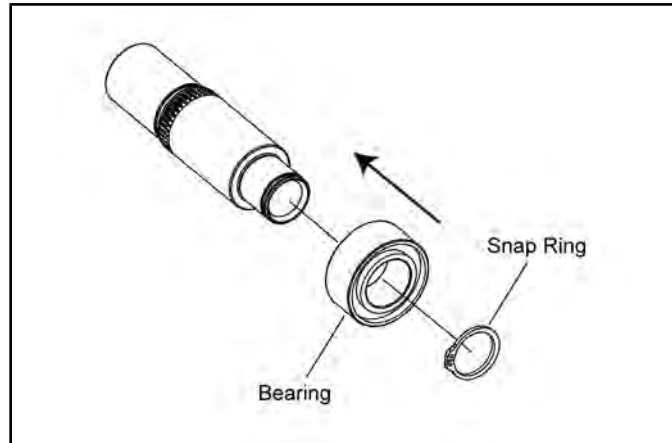

2. Install the shaft and bearing assembly into the outer sheave.

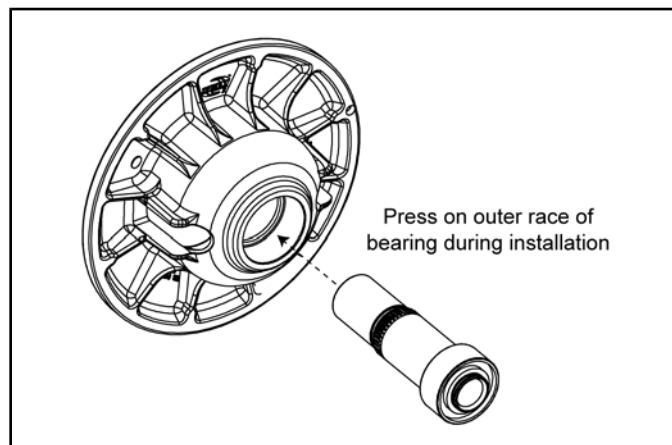

**NOTE:** Press only on the outer race of the bearing during installation to prevent damaging the bearing.

## CLUTCHING

- Line up the "X" on the moveable sheave with the "X" on the stationary sheave or use the marks previously used. Put the sheaves together.

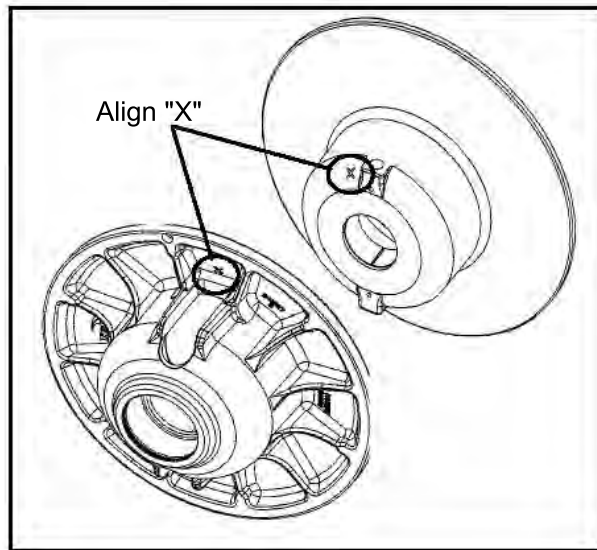

- Install the roller pin into the sheave assembly on both sides. The flat side of the roller pin faces downward when the shaft side is laying flat on the bench.

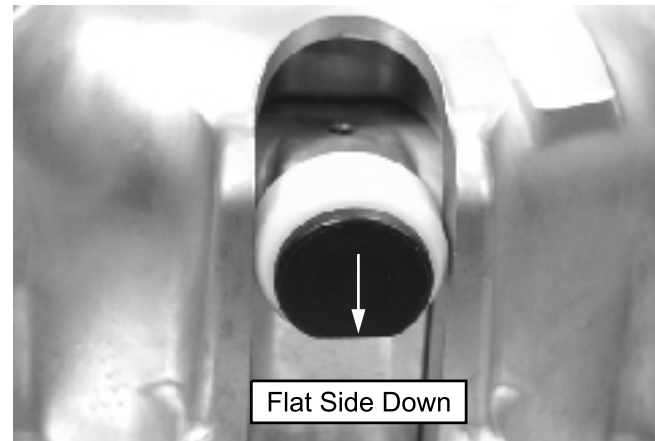

- Install the spring pins (C) to secure the roller pins. Install until flush with sheave surface.



6



- Install the roller (A) onto the roller pin (B) on both sides.

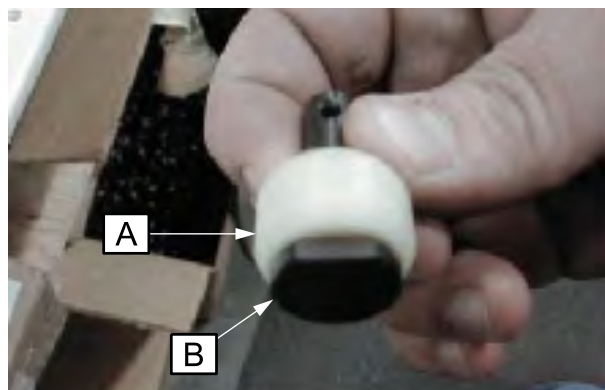

- Install the spring over the shaft.



- Install the clutch rollers (D) onto each side of the outside spider. Install the washers (E) and E-clips (F) to secure the rollers. The rollers should spin freely.

6.27

# CLUTCHING

9. Install the spider dampener (G) inside the outer spider and install the inside spider plate (H).

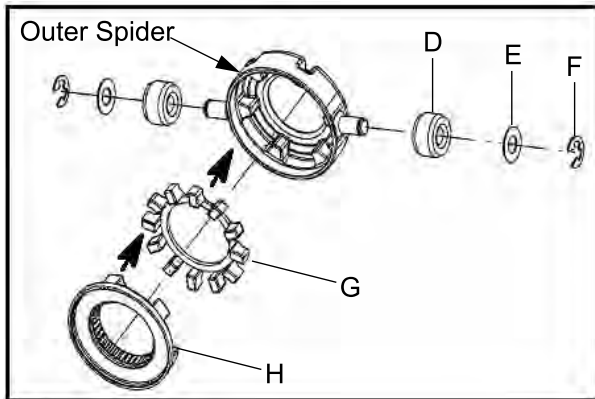

10. Install the spider assembly onto the shaft with the retaining ring on top of the spider. **NOTE:** Use the marks previously made to align the skip tooth spider, or use the "X" on top of the spider and align it with the skip tooth on the shaft.

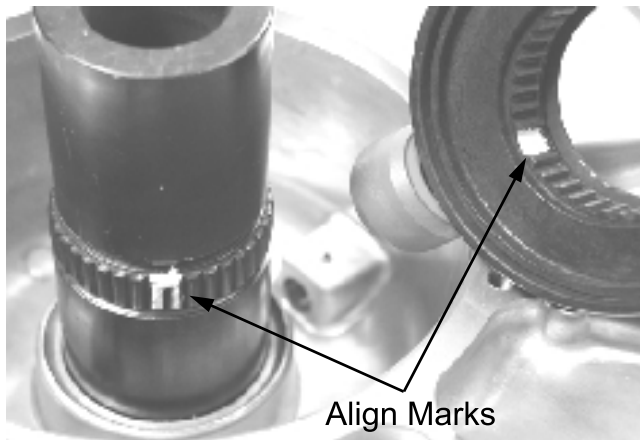

11. Place the driven clutch into the Universal Clutch Compressor **PU-50518**.

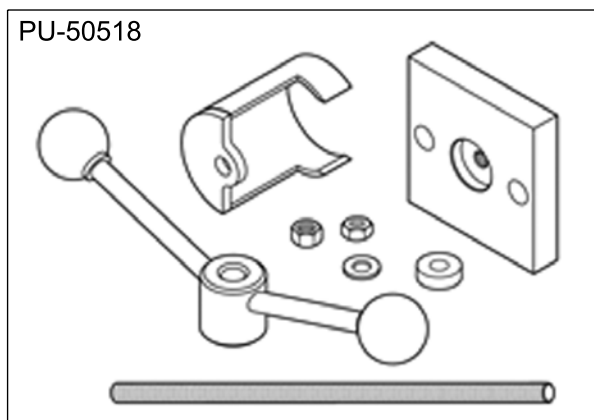

12. Press down on the top of the spider assembly, pushing the spider onto the shaft.

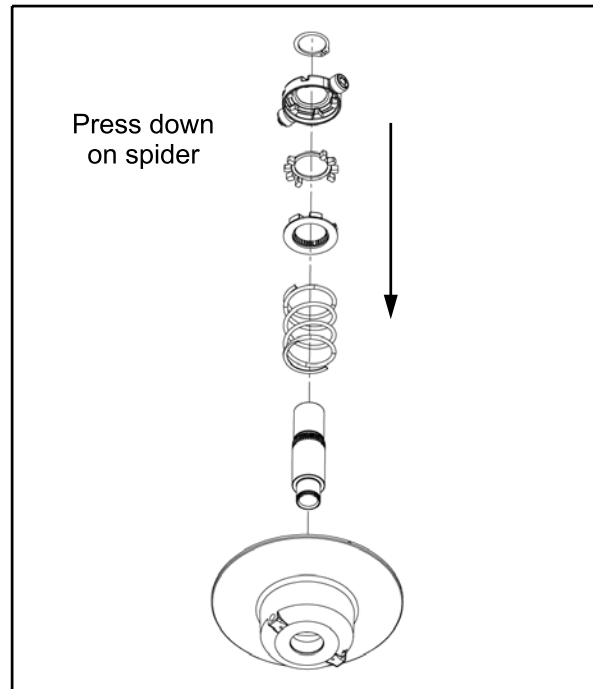

13. Slowly compress the spider into place. If the spider appears to bind while compressing, stop and make sure the skip-tooth on the shaft and the spider are aligned. Once the spider passes the retaining ring notch on the shaft, install the retaining ring.



## CLUTCHING

14. Install the cam (helix) assembly over the shaft. Line up the "X" on the cam, "X" on spider, and "X" on the stationary sheave or use the marks previously made before disassembly. **NOTE:** If the cam assembly (helix) is difficult to install, be sure the sheaves are aligned. To align the sheaves place the clutch assembly on a flat surface with the cam assembly (helix) side down. Press down on the moveable sheave belt face with both hands and the helix will release.



15. Use a T25 Torx driver to install the four helix retaining screws and torque to specification.



Helix Retaining Screws:  
48 in-lb (5 Nm)



## TROUBLESHOOTING

SITUATION	PROBABLE CAUSE	REMEDY
Engine RPM below specified operating range, although engine is properly tuned.	Wrong or broken drive clutch spring.	Replace with recommended spring.
	Drive clutch shift weight too heavy.	Install correct shift weight kit to match engine application.
	Driven clutch spring broken or installed in wrong helix location.	Replace spring; refer to proper installation location.
Erratic engine operating RPM during acceleration or load variations.	Drive clutch binding.	Disassemble drive clutch; inspect shift weights for wear and free operation.
		Clean and polish stationary shaft hub; reassemble clutch without spring to determine problem area.
	Belt worn unevenly - thin / burnt spots.	Replace belt.
	Driven clutch malfunction.	Replace ramp buttons.
		Inspect movable sheave for excessive bushing clearance.
Sheave face grooved.	Replace the clutch.	
Engine RPM above specified operating range.	Incorrect drive clutch spring (too high of rate).	Install correct recommended spring.
	Drive clutch shift weights incorrect for application (too light).	Install correct recommended shift weights.
	Drive clutch binding.	Disassemble and clean clutch, inspecting shift weights and rollers. Reassemble without the spring and move sheaves through entire range to further determine probable cause.
	Driven clutch binding.	Disassemble, clean, and inspect driven clutch, noting worn sheave bushing and ramp buttons and helix spring location.
	Converter sheaves greasy; belt slippage.	Clean sheaves with denatured alcohol or brake cleaner, install new belt.
Harsh drive clutch engagement.	Drive belt worn too narrow.	Replace belt.
	Excessive belt / sheave clearance with new belt.	Perform belt / sheave clearance adjustment with shim washers beneath spider.
Drive belt turns over	Wrong belt for application.	Replace with correct belt.
Belt burnt, thin spots	Abuse (continued throttle application when vehicle is stationary, excess load)	Caution operator to operate machine within guidelines.
	Dragging brake	Inspect brake system.
	Slow, easy clutch engagement	Fast, effective use of throttle for efficient engagement.



## CLUTCHING

SITUATION	PROBABLE CAUSE	REMEDY
PVT cover overheating (melting)	Plugged air intake or outlet.	Clear obstruction
	Belt slippage due to water, oil, grease, etc., rubbing on cover.	Inspect system. Clean , repair or replace as necessary. Seal PVT system ducts.
	Clutches or weight being applied to cover while in operation.	Remove weight. Inform operator.
	High vs. low range.	Instruct operator on guidelines for operation in proper driving range for different terrain as outlined in Owner's Safety and Maintenance Manual.
Water ingestion	Cover seals or ducts leaking	Find leak and repair as necessary.
	Operator error	Instruct operator on guidelines for operation in wet terrain as outlined in Owner's Safety and Maintenance Manual.
Belt slippage	Belt worn out	Replace belt.
	Water ingestion	Inspect and seal PVT system.
	Belt contaminated with oil or grease	Inspect and clean.
PVT noise	Belt worn or separated, thin spots, loose belt	Replace belt.
	Broken or worn clutch components, cover hitting clutches	Inspect and repair as necessary.
Engagement erratic or stabby	Thin spots on belt, worn belt	Replace belt. Refer to belt burnt troubleshooting and instruct operator.
	Drive clutch bushings stick	Inspect and repair clutches.

# CHAPTER 7

## FINAL DRIVE

GENERAL INFORMATION .....	7.2
SPECIAL TOOLS .....	7.2
FINAL DRIVE TORQUE SPECIFICATIONS .....	7.2
FRONT BEARING CARRIER .....	7.3
BEARING CARRIER INSPECTION / REMOVAL .....	7.3
BEARING REPLACEMENT .....	7.4
BEARING CARRIER INSTALLATION .....	7.4
FRONT DRIVE SHAFT .....	7.6
DRIVE SHAFT REMOVAL .....	7.6
DRIVE SHAFT INSTALLATION .....	7.7
FRONT PROPSHAFT SERVICE .....	7.8
FRONT PROPSHAFT REMOVAL .....	7.8
FRONT PROP SHAFT INSTALLATION .....	7.9
REAR PROP SHAFT REMOVAL .....	7.10
REAR PROP SHAFT INSTALLATION .....	7.10
REAR PROP SHAFT REMOVAL XP 4 .....	7.12
REAR PROP SHAFT INSTALLATION XP 4 .....	7.12
SUPPORT BEARING REPLACEMENT .....	7.13
PROP SHAFT U-JOINT SERVICE .....	7.15
FRONT GEARCASE / CENTRALIZED HILLIARD .....	7.16
CENTRALIZED HILLIARD ASSEMBLY VIEW .....	7.16
ALL WHEEL DRIVE OPERATION .....	7.17
AWD DIAGNOSIS .....	7.17
FRONT GEARCASE REMOVAL .....	7.18
FRONT GEARCASE DISASSEMBLY / INSPECTION .....	7.19
FRONT GEARCASE ASSEMBLY .....	7.22
FRONT GEARCASE INSTALLATION .....	7.25
REAR BEARING CARRIER .....	7.26
BEARING CARRIER INSPECTION / REMOVAL .....	7.26
BEARING REPLACEMENT .....	7.27
BEARING CARRIER INSTALLATION .....	7.28
REAR DRIVE SHAFT .....	7.30
DRIVE SHAFT REMOVAL .....	7.30
DRIVE SHAFT INSTALLATION .....	7.31
DRIVE SHAFT CV JOINT / BOOT REPLACEMENT .....	7.33
DRIVE SHAFT / CV JOINT HANDLING TIPS .....	7.33
OUTER CV JOINT / BOOT REPLACEMENT .....	7.33
INNER PLUNGING JOINT / BOOT REPLACEMENT .....	7.35
DRIVE SHAFT ASSEMBLY VIEW .....	7.38
WHEEL HUBS .....	7.39
FRONT HUB ASSEMBLY VIEW .....	7.39
REAR HUB ASSEMBLY VIEW .....	7.39



# FINAL DRIVE

---

## GENERAL INFORMATION

### SPECIAL TOOLS

PART NUMBER	TOOL DESCRIPTION
2872608	Roll Pin Removal Tool
8700226	CV Boot Clamp Pliers (earless type)
PU-48951	Axle Boot Clamp Tool

**Bosch Automotive Service Solutions:** 1-800-345-2233  
or <http://polaris.service-solutions.com/>

### Final Drive Torque Specifications

ITEM	SPECIFICATION
Wheel Lug Nuts	<b>120 ft-lbs (163 Nm)</b>
Hub Castle Nut (front and rear)	<b>110 ft-lbs (149 Nm)</b>
Ball Joint Pinch Fasteners	<b>42 ft-lbs (57 Nm)</b>
Brake Caliper Mounting Bolts	<b>40 ft-lbs (54 Nm)</b>
Tie Rod End Fastener	<b>15 ft-lbs (20 Nm) + 90°</b>
Propshaft Support Bearing Fasteners	<b>35 ft-lb (47 Nm)</b>
Front Gearcase Cover Plate Screws	<b>11 ft-lbs (15 Nm)</b>
Front Gearcase Mounting Bolts	<b>30 ft-lbs (41 Nm)</b>
Bearing Carrier to Trailing Arm Bolts	<b>42 ft-lb (54 Nm)</b>
Radius Rod Fasteners	<b>40 ft-lb (54 Nm)</b>

## FRONT BEARING CARRIER

### Bearing Carrier Inspection / Removal

1. Elevate front of vehicle and safely support machine under the frame area.

#### CAUTION

Serious injury may result if machine tips or falls. Be sure machine is secure before beginning this service procedure. Wear eye protection when removing bearings and seals.

2. Check bearings for side play by grasping the top and bottom of the tire firmly and checking for movement. The tire should rotate smoothly without binding or rough spots.

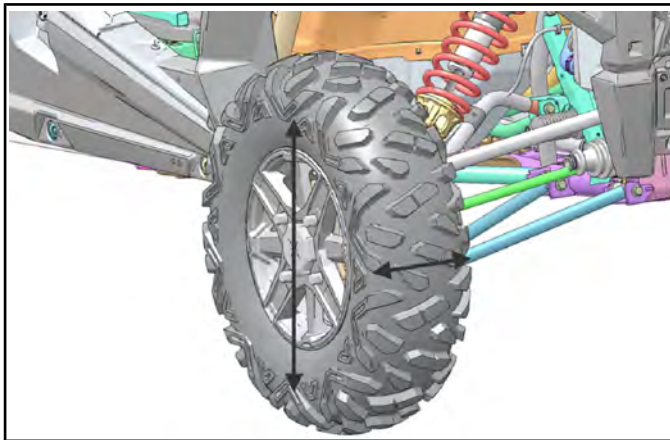

3. Remove the four wheel nuts and remove the front wheel.
4. Remove the cotter pin (Item 1) and loosen the front wheel hub castle nut (Item 2). Remove the nut, and (2) cone washers (Item 3) from the front wheel hub assembly.

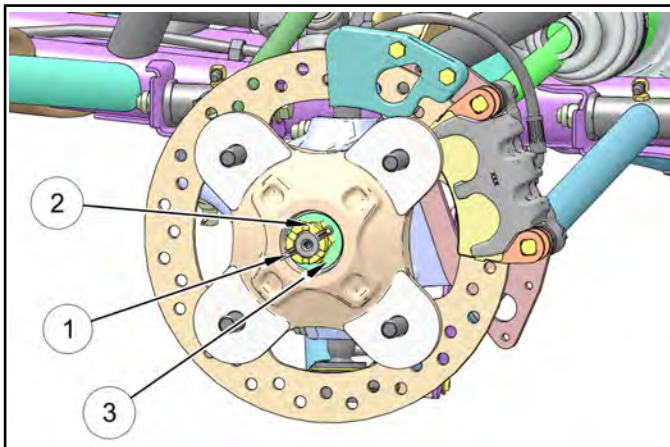

5. Remove the fastener retaining the steering tie rod end to the front bearing carrier.
6. Remove and discard the two front brake caliper mounting bolts and remove the caliper from the brake disc (see Chapter 9- Caliper Removal, page 9.14).
7. **CAUTION:** Do not hang the caliper by the brake line. Use wire to hang caliper to prevent damage to the brake line.
8. Remove the front wheel hub assembly.
9. Remove and discard the upper and lower ball joint pinch bolts (Item 4).

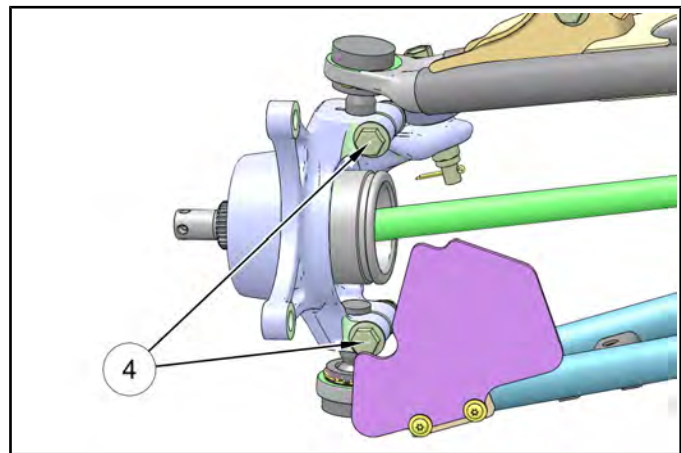

10. Using a soft faced hammer, lightly tap on the bearing carrier while removing the upper and lower ball joint ends.
11. Remove the bearing carrier from the front drive shaft.
12. Rotate bearing by hand and check for smooth rotation. Visually inspect bearing for moisture, dirt, or corrosion.

**NOTE:** Due to extremely close tolerances and minimal wear, the bearings must be inspected visually, and by feel. While rotating bearings by hand, inspect for rough spots, discoloration, or corrosion. The bearings should turn smoothly and quietly, with no detectable up and down movement and minimal movement sideways between inner and outer race.

13. Replace bearing if moisture, dirt, corrosion, or roughness is evident.

# FINAL DRIVE

## Bearing Replacement

### Bearing Removal

1. Remove the outer snap ring (Item 1).

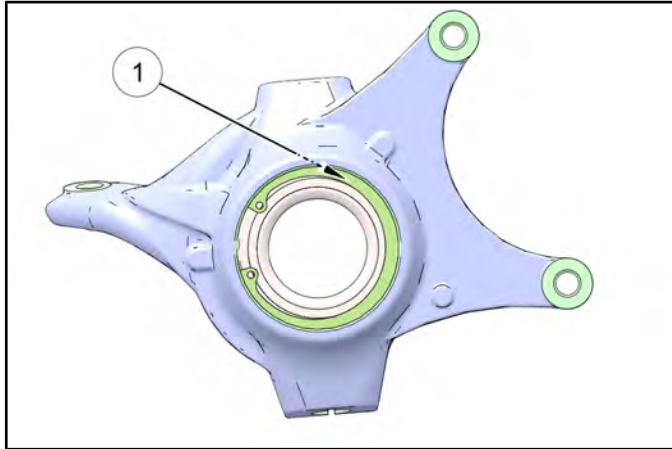

2. From the back side of the bearing carrier, tap on the outer bearing race with a drift punch in the reliefs as shown.

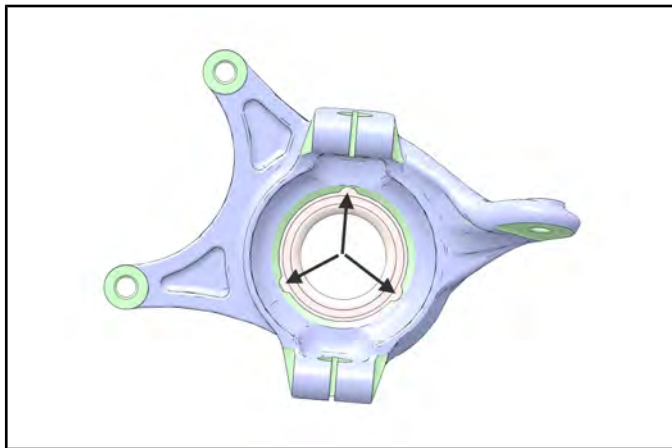

3. Drive bearing out evenly by tapping on outer race only. Once bearing is at bottom of casting, support casting on outer edges so bearing can be removed.
4. Inspect the bearing carrier housing for scratches, wear or damage. Replace front bearing carrier if damaged.

### Bearing Installation

5. Thoroughly clean the front bearing carrier housing and the outer race on the new bearing. Be sure that all oil residue has been removed from each surface.
6. Support the bottom of the bearing carrier housing.

### CAUTION

Use an arbor and press only on the outer race, otherwise bearing damage may occur.

7. Apply **Loctite® 603™** retaining compound to the outer circumference of the new bearing (Item 2) race and carefully press the new bearing into the bearing carrier housing.

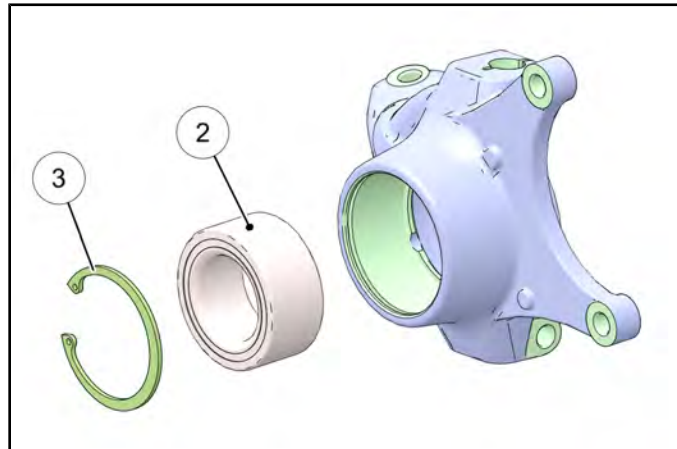

**NOTE: Use care to not allow any of the Loctite® compound to get in the bearing.**

8. Wipe the housing clean of any excess compound and install the snap ring (Item 3).

### Bearing Carrier Installation

1. Install drive shaft axle through the backside of the bearing carrier.
2. Install the upper and lower ball joint ends into the front bearing carrier.
3. Install **new** pinch bolts (Item 1) and nuts. Torque to specification.

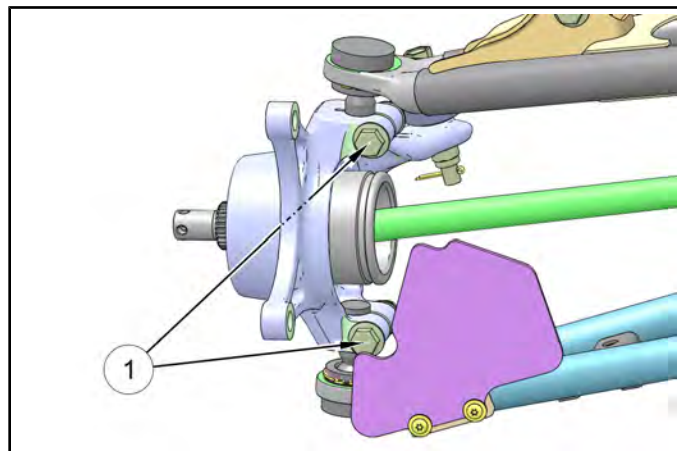

Ball Joint Pinch Bolts:  
**42 ft-lbs (57 Nm)**

4. Apply Anti-Seize to drive shaft axle splines.
5. Install front wheel hub assembly (Item 2), cone washers (Item 3), and hand tighten the castle nut. Install washers with domed side out.

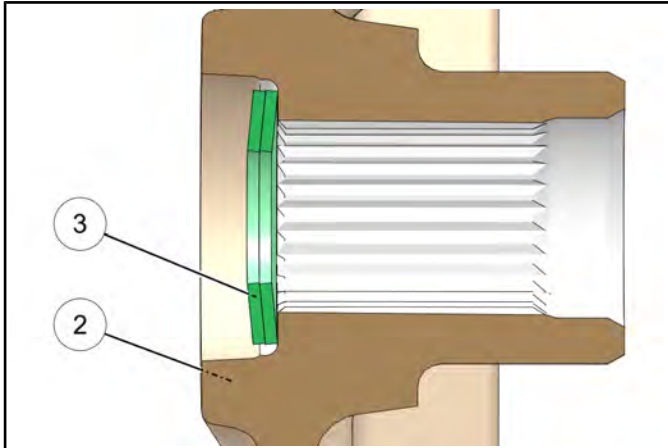

6. Install **new** brake caliper mounting bolts and torque to specification.



Front Caliper Mounting Bolts:  
**40 ft-lbs (54 Nm)**

### CAUTION

New bolts have a pre-applied locking agent which is destroyed upon removal. Always use new brake caliper mounting bolts upon assembly.

7. Install the steering tie rod end (Item 4) onto the front bearing carrier.

**NOTE:** Refer to the photos below to ensure proper placement of the tie rod end.

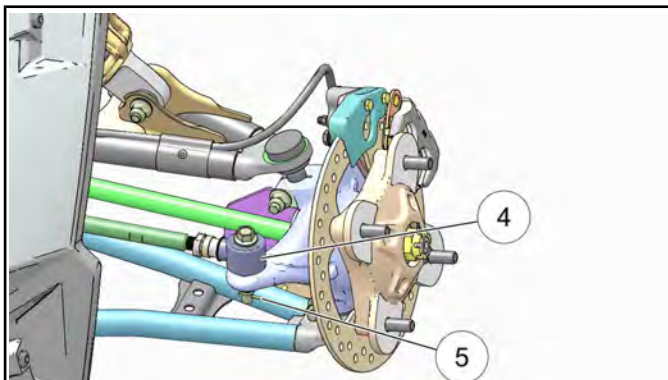

8. Torque the tie rod end fastener (Item 5) to specification and install a **new** cotter pin (Item 5).



Tie Rod End Fastener:  
**15 ft-lbs (20 Nm) + 90°**

9. Torque wheel hub nut (Item 6) to specification and install a **new** cotter pin (Item 7). Tighten nut slightly if necessary to align cotter pin holes. Bend both ends of cotter pin around end of spindle in different directions.

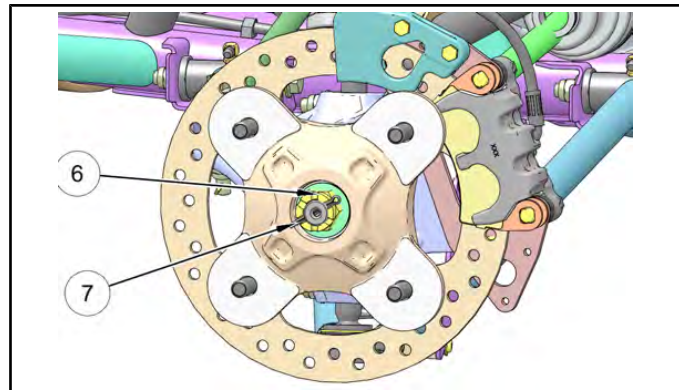

Wheel Hub Castle Nut:  
**110 ft-lbs (149 Nm)**

10. Install wheel and four wheel nuts. Torque wheel nuts to specification.



Wheel Nuts:  
**120 ft-lbs (163 Nm)**

11. Rotate wheel and check for smooth operation.

# FINAL DRIVE

## FRONT DRIVE SHAFT

### Drive Shaft Removal

1. Elevate front of vehicle and safely support machine under the frame area.

#### CAUTION

Serious injury may result if machine tips or falls. Be sure machine is secure before beginning this service procedure. Wear eye protection when removing bearings and seals.

2. Remove the four wheel nuts and remove the front wheel.
3. Remove the cotter pin (Item 1) and loosen the front wheel hub castle nut (Item 2). Remove the nut, and cone washers (Item 3) from the front wheel hub assembly.

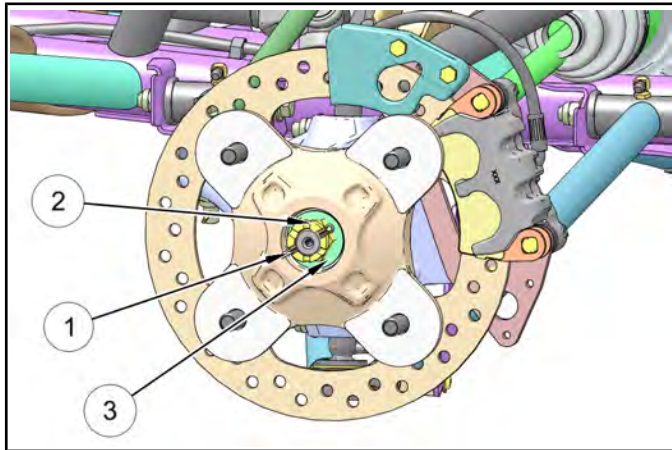

4. Remove and discard the two front brake caliper mounting bolts and remove the caliper from the brake disc (see Chapter 9).
5. **CAUTION:** Do not hang the caliper by the brake line. Use wire to hang caliper to prevent damage to the brake line.
6. Remove the front wheel hub assembly.

7. Remove and discard the upper and lower ball joint pinch bolts (Item 4) and nuts.

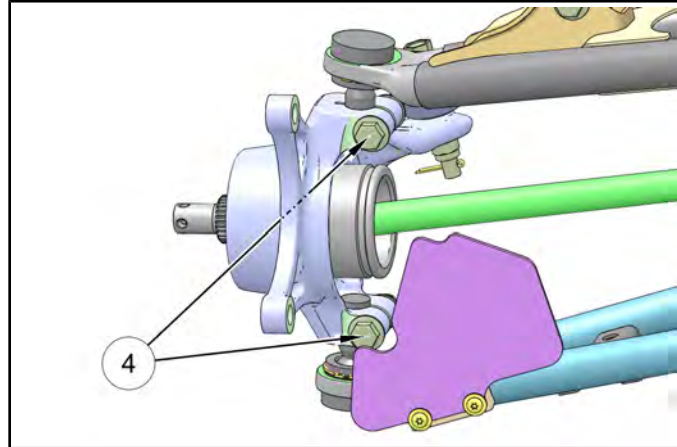

8. Using a soft faced hammer, lightly tap on the bearing carrier while removing the upper ball joint end.
9. Remove the drive shaft from the front bearing carrier.

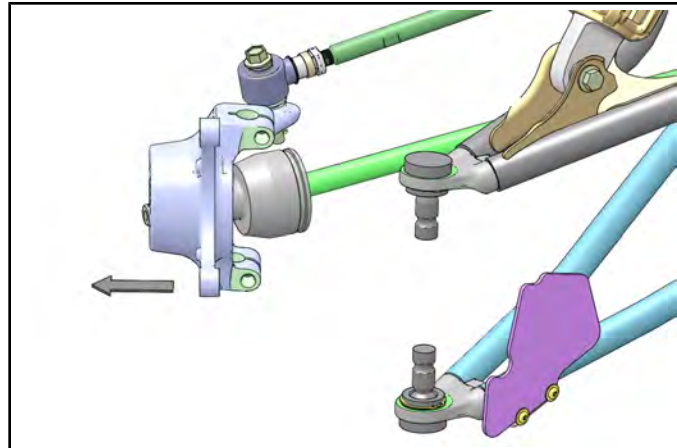

10. With a short, sharp jerk, remove drive shaft from the front gearcase.

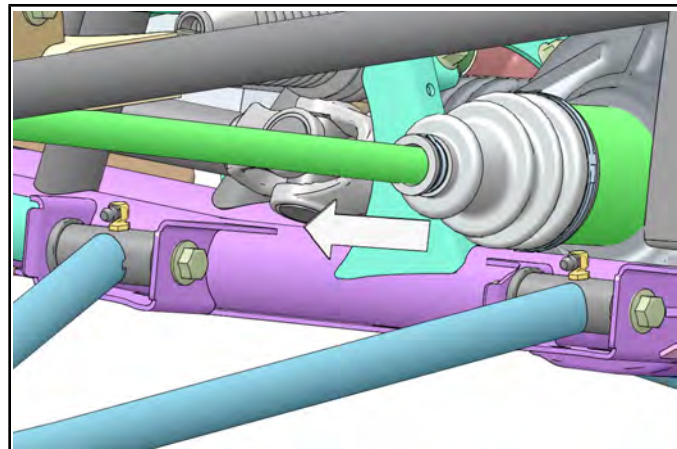

## Drive Shaft Installation

1. Install **new** spring ring (Item 1) on drive shaft. Apply an anti-seize compound to the splines (Item 2).

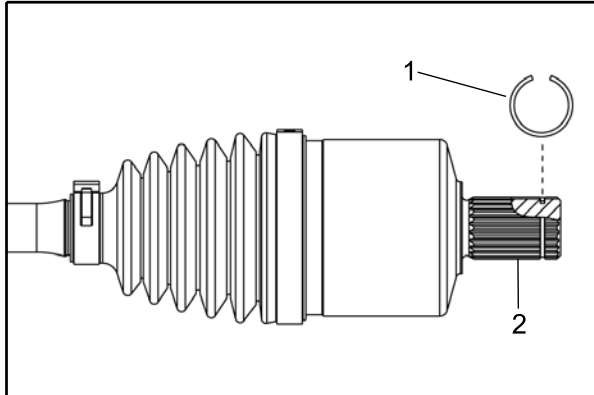

2. Align splines of drive shaft with front gearcase and reinstall the drive shaft. Use a rubber mallet to tap on the outboard end of the drive shaft if necessary

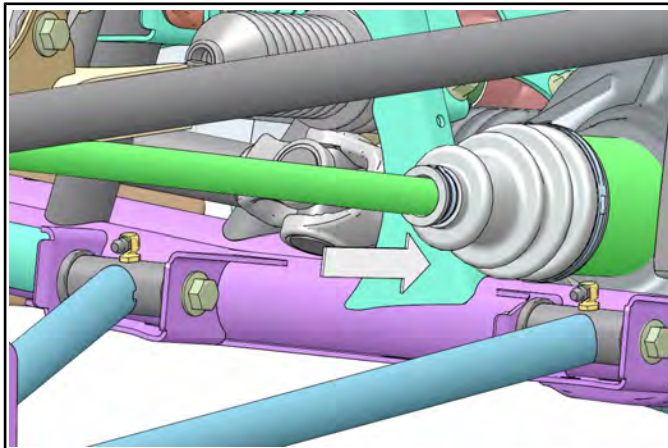

3. Install drive shaft into the front bearing carrier.

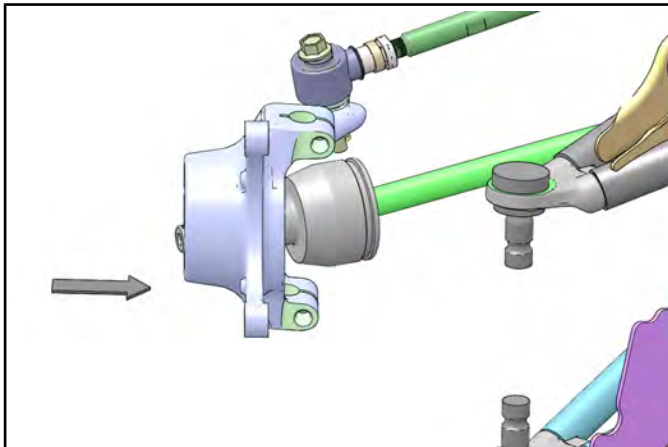

4. Install the upper and lower ball joint ends into the front bearing carrier.

5. Install **new** pinch bolts and nuts. Torque to specification.

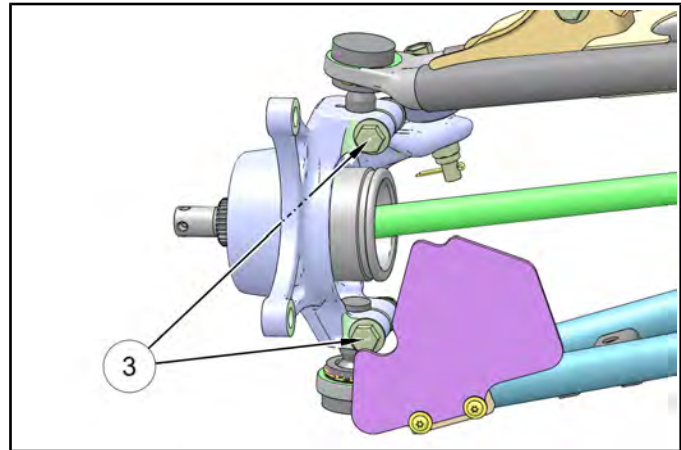

Ball Joint Pinch Bolts:  
42 ft-lbs (57 Nm)

6. Apply Anti-Seize to drive shaft axle splines.
7. Install front wheel hub assembly (Item 4), cone washers (Item 5), and hand tighten the castle nut. Install washers with domed side out.

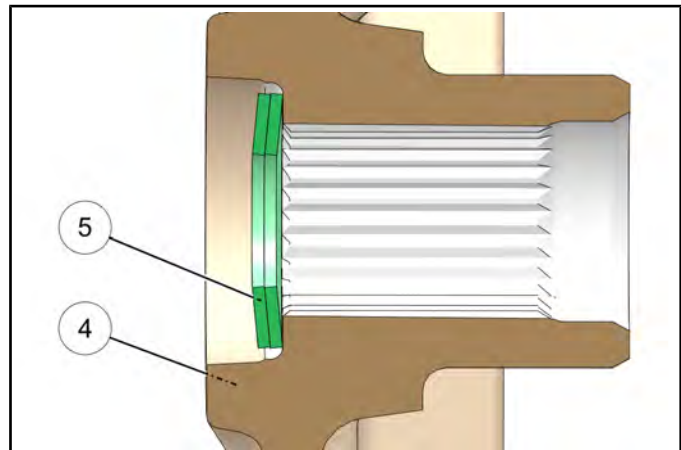



# FINAL DRIVE

- Torque wheel hub nut (Item 6) to specification and install a **new** cotter pin (Item 7). Tighten nut slightly if necessary to align cotter pin holes. Bend both ends of cotter pin around end of spindle in different directions.

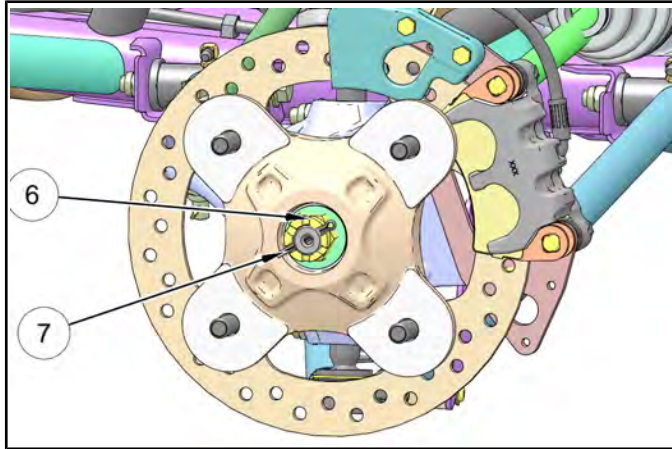

Wheel Hub Castle Nut:  
**110 ft-lbs (149 Nm)**

- Install **new** brake caliper mounting bolts and torque to specification.



Front Caliper Mounting Bolts:  
**40 ft-lbs (54 Nm)**

### CAUTION

New bolts have a pre-applied locking agent which is destroyed upon removal. Always use new brake caliper mounting bolts upon assembly.

- Install wheel and four wheel nuts. Torque wheel nuts to specification.



Wheel Nuts:  
**120 ft-lbs (163 Nm)**

- Rotate wheel and check for smooth operation.

## 7.8

# FRONT PROPSHAFT SERVICE

## Front Propshaft Removal

- Remove the center console.

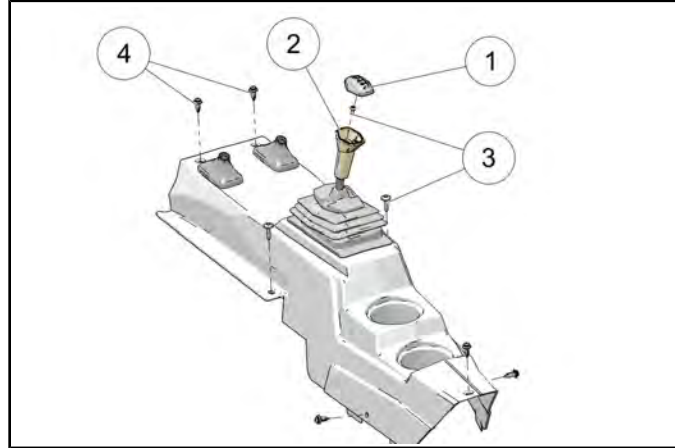

1. Cap

3. Torx Screw

2. Shifter

4. Push Rivet

- Locate the prop shaft roll pin and use the Roll Pin Removal Tool (PN 2872608) to remove the roll pin. Discard roll pin. Push the front prop shaft rearward to remove it from the front gearcase input shaft.

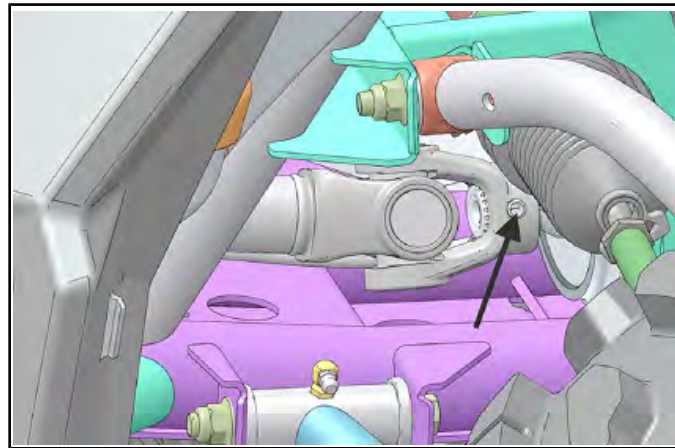

**Roll Pin Removal Tool:  
PN 2872608**

**NOTE:** Right front wheel can be removed to gain better access to the propshaft roll pin.

- Slide the front propshaft (Item 5) off the rear propshaft (Item 6) and remove it from the vehicle.

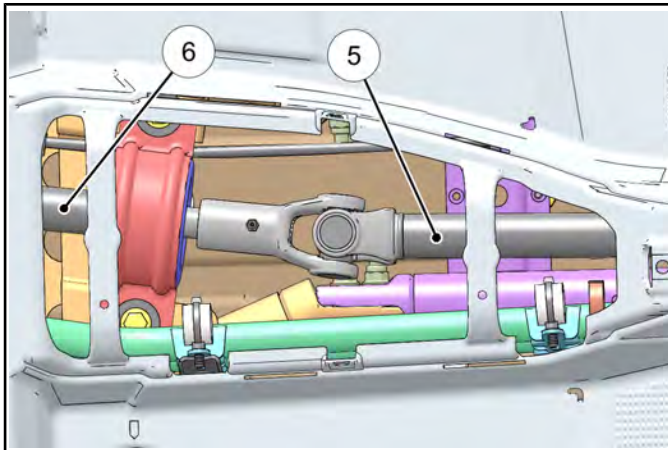

- Align the front and rear prop shafts as shown below and slide them together.

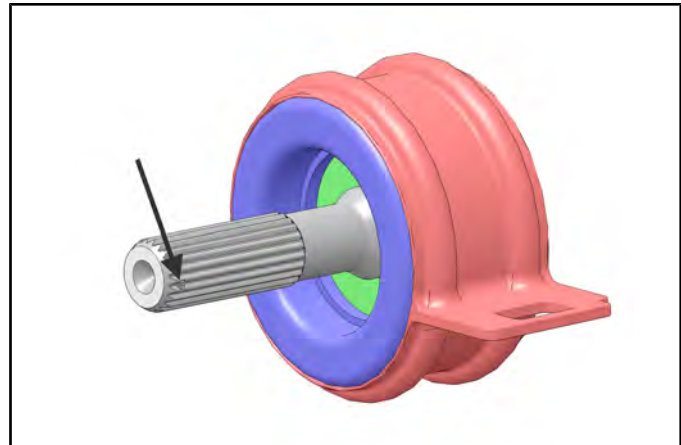

- Proceed to "Front Prop Shaft Installation".

## Front Prop Shaft Installation

- Reverse the appropriate "Front Propshaft Removal" procedure to reinstall the front propshaft.
- Lubricate front gearcase shaft splines with Anti-Seize.
- Lubricate the front and rear prop shaft mid joint with Polaris All Purpose Grease.



**NOTE:** Paint marks are applied to the front and rear prop shafts to aid shaft alignment. Reference these marks during installation if still visible.

- When installing the front prop shaft onto the front gearcase, use a new roll pin.
- Reposition the front gearcase and install the four bolts that secure the front gearcase to the frame. Torque bolts to specification.



Front Gearcase Mounting Bolts:  
30 ft-lbs (41 Nm)

# FINAL DRIVE

## Rear Prop Shaft Removal

1. Remove the center console.

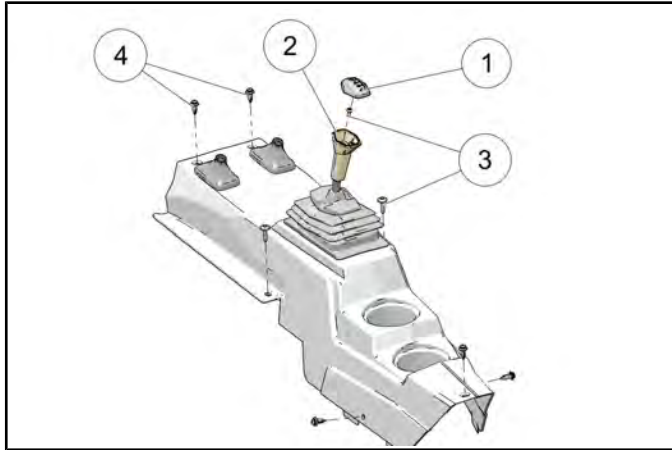

1. Cap	3. Torx Screw
2. Shifter	4. Push Rivet

2. Remove the two fasteners (Item 5) retaining the support bearing cover (Item 6) to the frame.

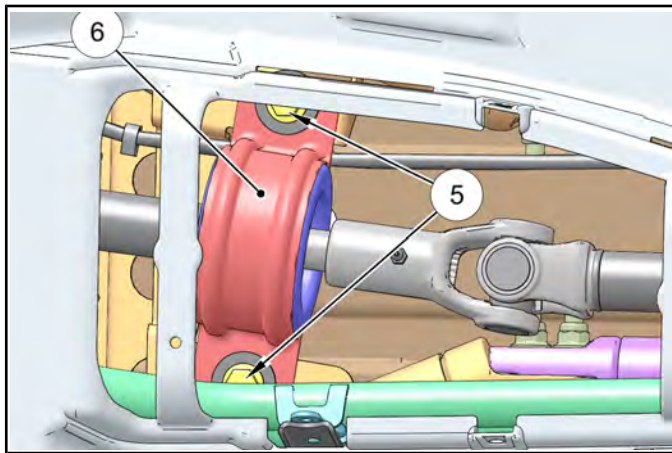

3. While moving the prop shaft support bearing assembly, slide the front prop shaft off the rear prop shaft and remove it from the vehicle.

4. Once the front and rear prop shafts have been separated, slide the rear prop shaft forward to remove it from the transmission output shaft.

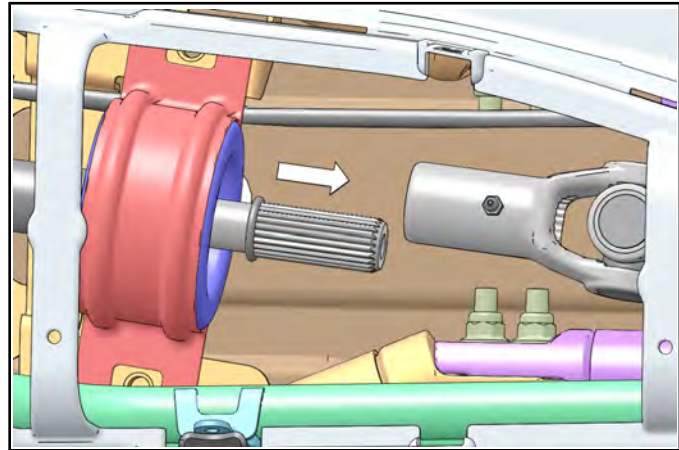

5. Remove the support bearing rubber bushing by pulling it off the rear prop shaft.
6. Remove the rear prop shaft out of the left rear of the vehicle.

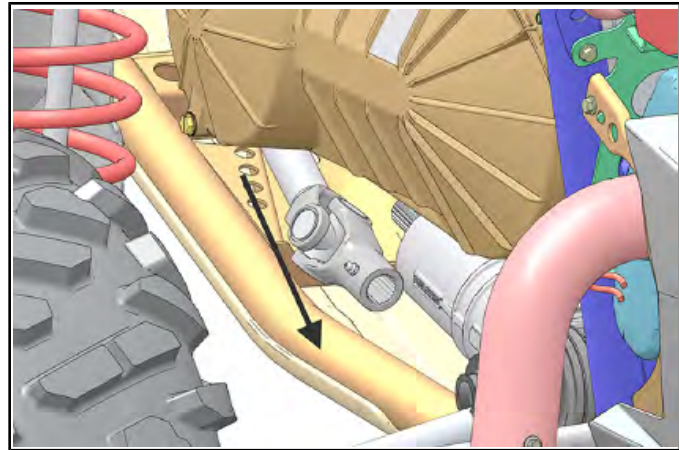

## Rear Prop Shaft Installation

1. Reverse the appropriate "Rear Prop Shaft Removal" procedure to reinstall the rear prop shaft.
2. Lubricate the transmission output shaft splines with Polaris All Purpose Grease.
3. Lubricate the front and rear prop shaft mid joint with Polaris All Purpose Grease.
4. Slide the rear prop shaft forward from the left rear of the machine just below the PVT cover. Install the rear prop shaft on the transmission snorkel shaft.
5. Lubricate the support bushing with light oil to ease installation and install the bushing on the rear prop shaft bearing.

# FINAL DRIVE

6. Align the front and rear prop shafts as shown below and slide them together.

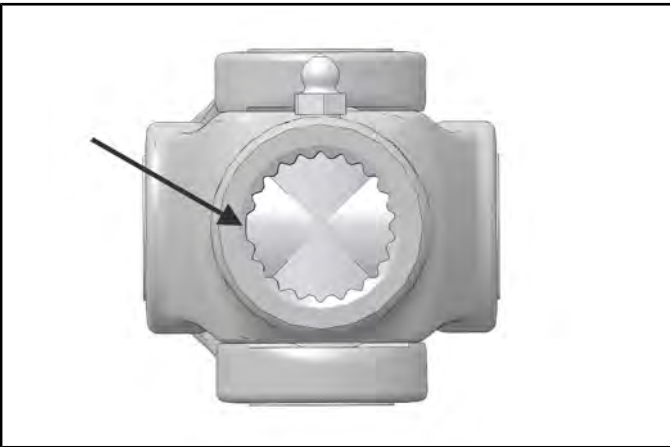
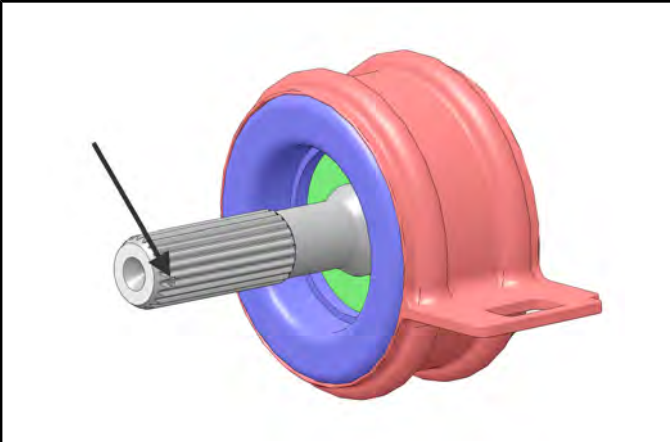

8. Align the front propshaft paint mark with the front gearcase input shaft mark so the pin holes align. Install a new roll pin.

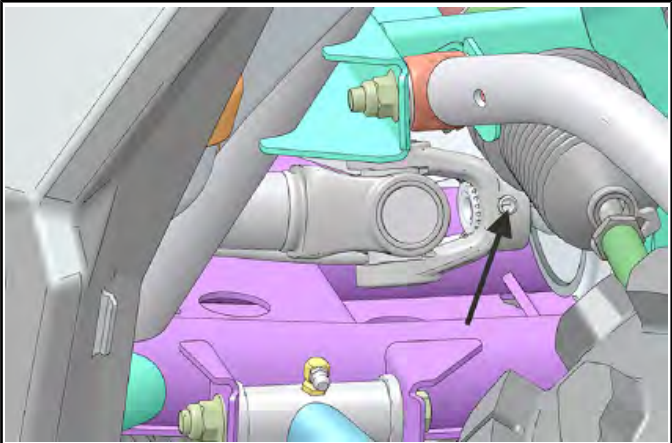

**NOTE:** Paint marks are applied to the front and rear prop shafts to aid shaft alignment. Reference these marks during installation if still visible.

7. Torque the support bearing fasteners to specification.

 = T
Support Bearing Fasteners: <b>35 ft-lb (47 Nm)</b>

# FINAL DRIVE

## Rear Prop Shaft Removal XP 4

1. Remove all seats.
2. Remove the front and rear center consoles (see Body Component Removal - Rocker Panels, Rear Console and Floor XP 4).
3. Remove the fasteners (Item 1) from center (Item 2) and rear skid plates (Item 3).

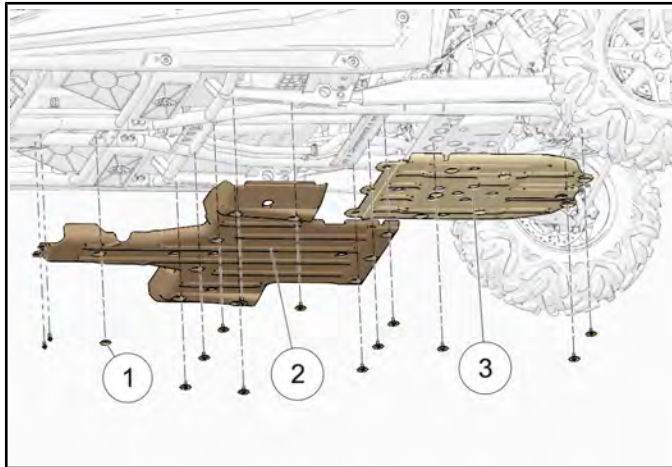

4. Remove center and rear skid plates.
5. Remove the fasteners (Item 4) securing the support bearing cover (Item 5) to the frame.

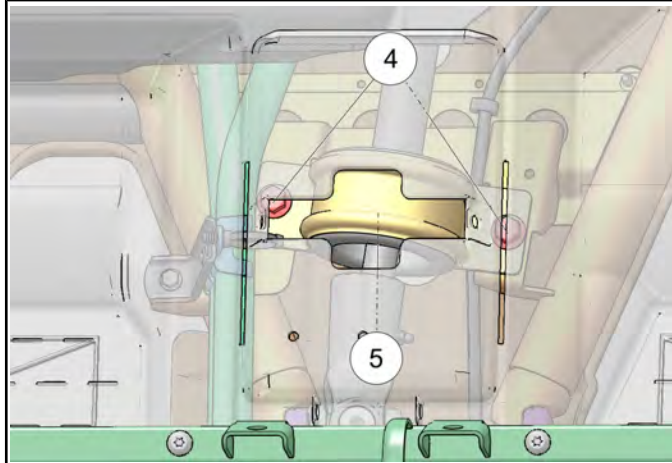

6. Move the prop shaft support bearing assembly to the drivers side to slide the rear prop shaft yoke (Item 6) off the transmission output shaft.

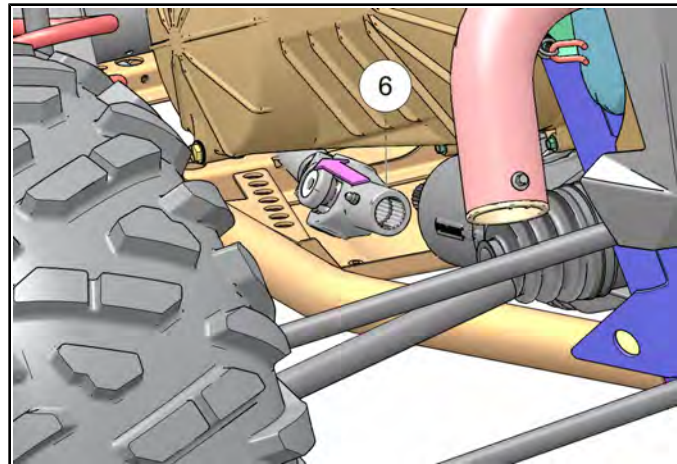

7. Slide the prop shaft to the rear of the vehicle until the front of the shaft clears the frame support and slide the prop shaft forward out of the vehicle.

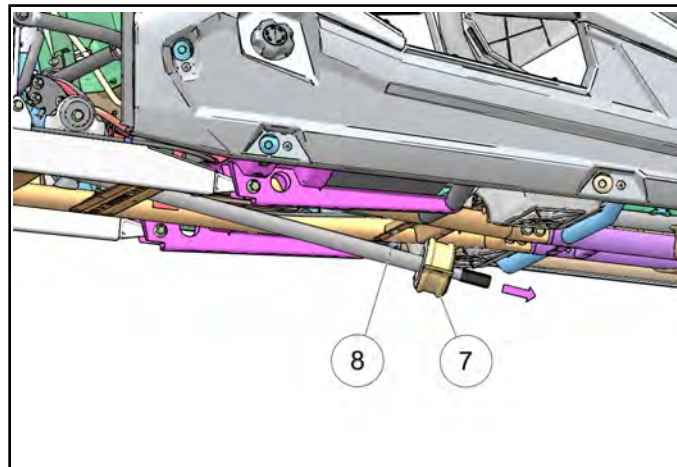

## Rear Prop Shaft Installation XP 4

1. Reverse the appropriate "Rear Prop Shaft Removal" procedure to reinstall the rear prop shaft.
2. Lubricate the transmission output shaft splines with Polaris All Purpose Grease.
3. Lubricate the front and rear prop shaft mid joint with Polaris All Purpose Grease.
4. Align the front and rear prop shafts and slide them together.

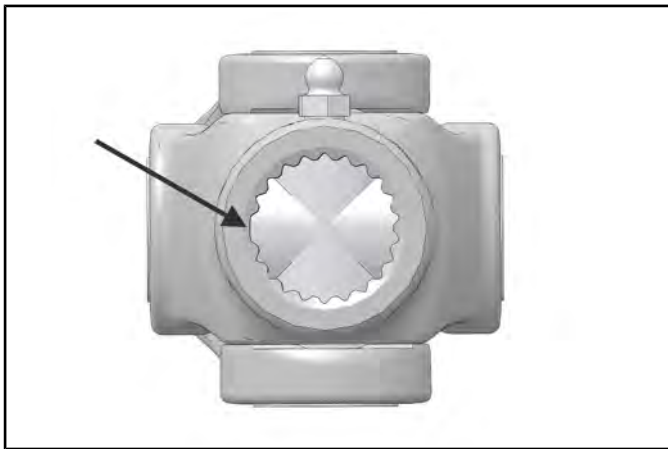
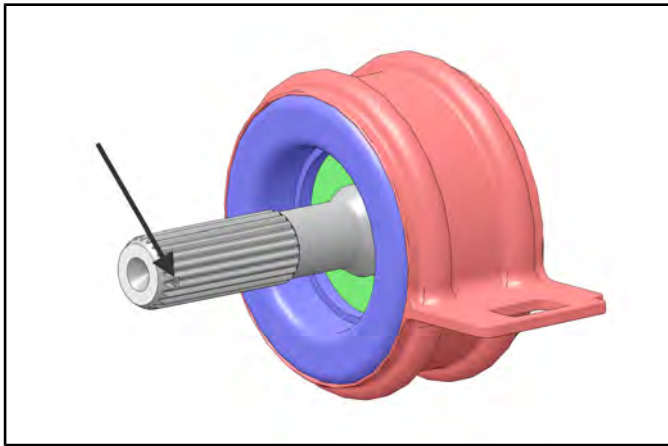

**NOTE:** Paint marks are applied to the front and rear propshafts to aid shaft alignment. Reference these marks during installation if still visible.

5. Torque the support bearing fasteners to specification.



Support Bearing Fasteners:  
35 ft-lb (47 Nm)

## Support Bearing Replacement

1. Remove the rear prop shaft from the vehicle (see "Rear Propshaft Removal" procedure).
2. Using a rubber mallet, remove the rubber isolated bearing support from the shaft to expose the bearing.

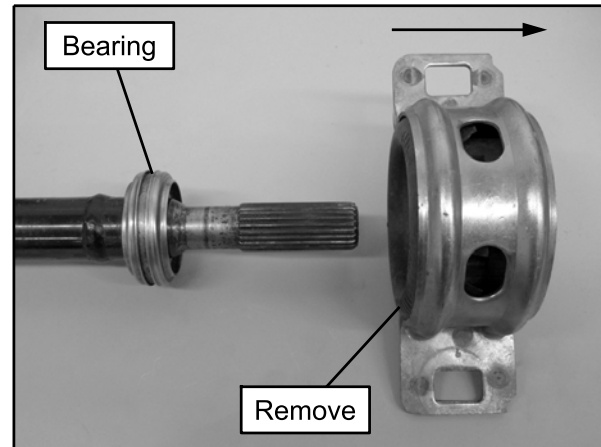

3. Using a commercially available 2-jaw puller, remove the bearing from the end of the propshaft.
4. Clean the bearing mounting surface on the shaft and apply **Loctite® 603™** retaining compound to the clean surface.

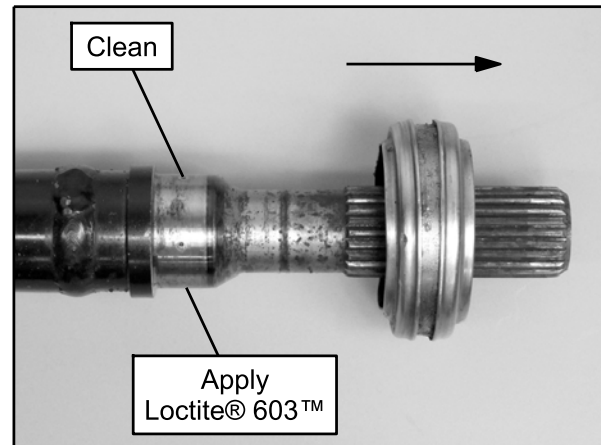

5. Install the new support bearing assembly onto the end of the prop shaft.

**NOTE:** Do not attempt to separate the bearing from the rubber isolated support assembly upon installation.

7

## FINAL DRIVE

---

- Using an appropriate bearing/bushing installation sleeve, drive the support bearing assembly onto the propshaft until it seats against the shoulder on the shaft.

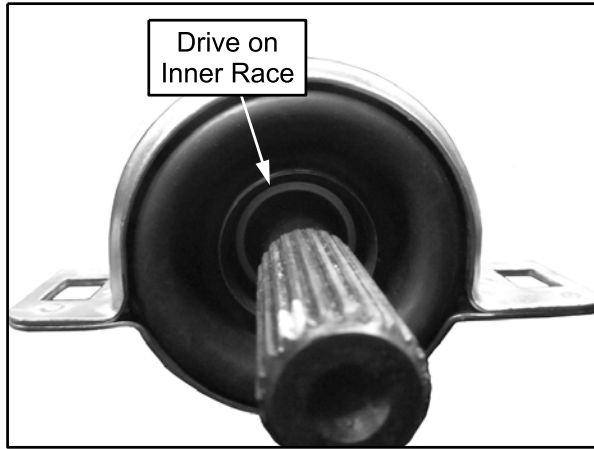

**NOTE:** Take care while installing the support bearing assembly. Be sure to only drive on the inner race of the bearing. Driving on the bearing or support in any other location will damage the bearing or support assembly.

- Wipe the bearing and shaft clean of any excess retaining compound.

**NOTE:** Use care to not allow any of the Loctite® compound to get in the bearing.

- Install the rear prop shaft into the vehicle (see “**Rear Prop Shaft Installation**” procedure).

### **Prop Shaft U-Joint Service**

The prop shafts on this unit are not serviceable. If a cross or yoke is worn, the prop shaft assembly needs to be replaced.



# FINAL DRIVE

## FRONT GEARCASE / CENTRALIZED HILLIARD

### Centralized Hilliard Assembly View

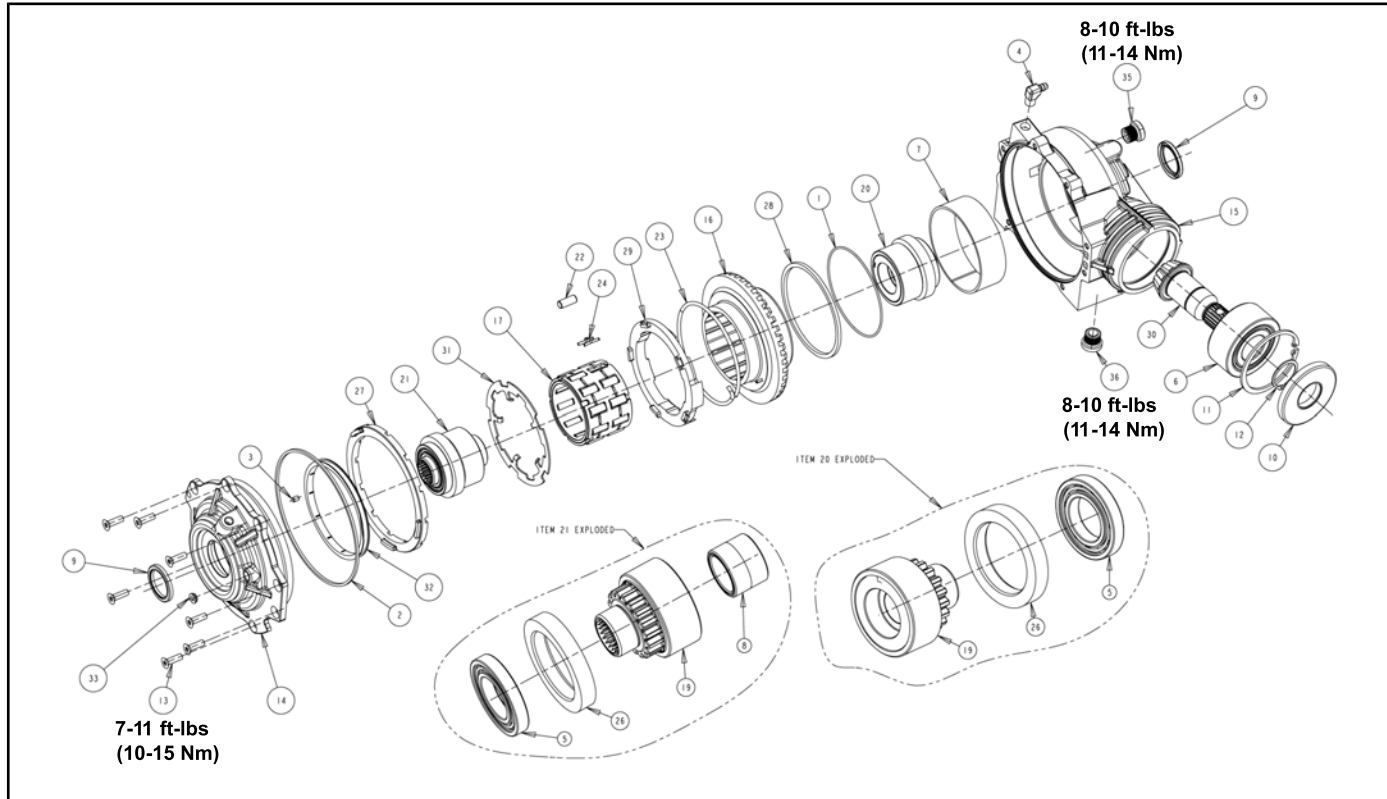

REF#	DESCRIPTION	QTY	REF#	DESCRIPTION	QTY
1	O-Ring	1	17	Roll Cage	1
2	O-Ring	1	19	Hub / Race Assembly	2
3	Dowel Pin	1	20	Hub Sub-Assembly (Female)	1
4	Vent Hose Fitting	1	21	Hub Sub-Assembly (Male)	1
5	Ball Bearing	2	22	Rollers	20
6	Ball Bearing (Double Row)	1	23	Torsion Spring	1
7	Bushing	1	24	H-Clip Spring	20
8	Bushing	1	26	Nylon Spacer	2
9	Oil Seal	2	27	Backlash Spacer	1
10	Oil Seal	1	28	Ring Gear Spacer	1
11	Retaining Ring, Internal	1	29	Torsion Spring Retainer	1
12	Retaining Ring	1	30	Pinion Gear	1
13	Cover Screws, M6 (T30 Torx)	7	31	Armature Plate	1
14	Cover Plate Assembly	1	32	AWD Coil	1
15	Gearcase Housing	1	35	Fill Plug	1
16	Clutch Housing (Ring Gear)	1	36	Drain Plug, Magnetic	1

## All Wheel Drive Operation

The AWD switch may be turned on or off while the vehicle is moving, however, AWD will not enable until the engine RPM drops below 3100. Once the AWD is enabled, it remains enabled until the switch is turned off.

Engage the AWD switch before getting into conditions where the front wheel drive may be needed. If the rear wheels are spinning, release the throttle before switching to AWD.

### CAUTION

Switching to AWD while the rear wheels are spinning may cause severe drive shaft and gearcase damage. Always switch to AWD while the rear wheels have traction or are at rest.

With the AWD switch off, the vehicle drives through the rear wheels only (2 wheel drive). When the AWD is enabled, the front drive acts as an on-demand AWD system. This means, the front drive will engage once the rear wheels have lost traction, and will remain engaged until the torque requirement goes away (i.e. rear wheels regain traction).

### CAUTION

If the rear wheels are spinning, release the throttle before turning the AWD switch on.  
If AWD is engaged while the wheels are spinning, severe drive shaft and front gearcase damage could result.

**AWD Engagement:** When the AWD switch is activated, the AWD coil is powered by a 12 Vdc input which creates a magnetic field. This magnetic field attracts an armature plate that is keyed to the roll cage. When the ring gear and roll cage are spinning (vehicle is moving), the energized coil and armature plate will apply drag to the roll cage that indexes the rollers inside the ring gear to an engagement position. While in the engagement position, the front drive will be in an “over-running” condition (not engaged), until the rear wheels lose traction. Once the rear wheels begin to lose traction, the front drive will engage by coupling the output hubs to the ring gear via the rollers. The front drive will remain engaged until the torque requirement goes away (i.e. rear wheels regain traction).

**AWD Disengagement:** Once the rear wheels regain traction, the front wheels will return to the “over-running” condition. The vehicle is now back to rear wheel drive until the next loss of rear wheel traction occurs.

**Torsion Spring Operation:** The torsion spring acts as a return mechanism to help disengage the coupling of the

output hubs and ring gear by creating an “over-running” condition for the rollers upon disengagement.

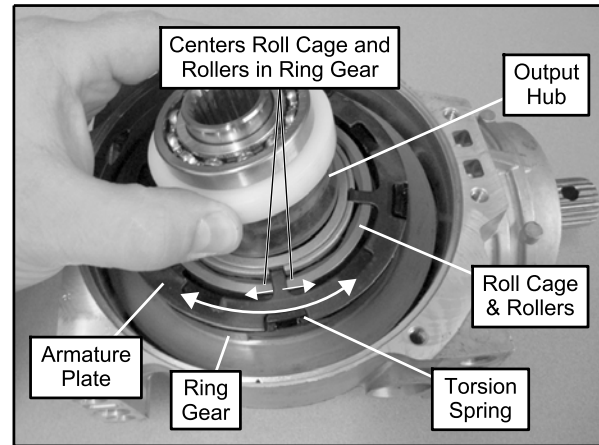

## AWD Diagnosis

### Symptom: AWD Will Not Engage

1. Check the gearcase coil resistance. To test the coil resistance, measure between Grey and Brown/White wires. Measurement should be within specification.

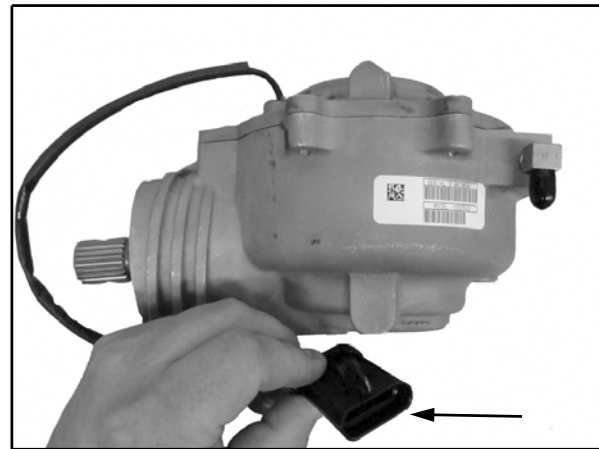

**Front Gearcase Coil Resistance:  
21.6 - 26.4 Ohms**

2. Turn on ignition and AWD switches and place gear selector in High or Low. Check for minimum battery voltage at Gray and Brown/White chassis wires that power the coil. Should have a minimum of 11 Vdc.
3. If electrical tests are within specification, remove gearcase (see “Gearcase Removal”) and inspect components.

7

## FINAL DRIVE

4. Inspect armature plate for a consistent wear pattern. There should be two distinct wear bands (one band inside the other). If only one band of wear is present (or if there is wear between the two bands), inspect the coil area as indicated in Step 5. A wear band with an interrupted wear mark may indicate a warped plate, which may cause intermittent operation.

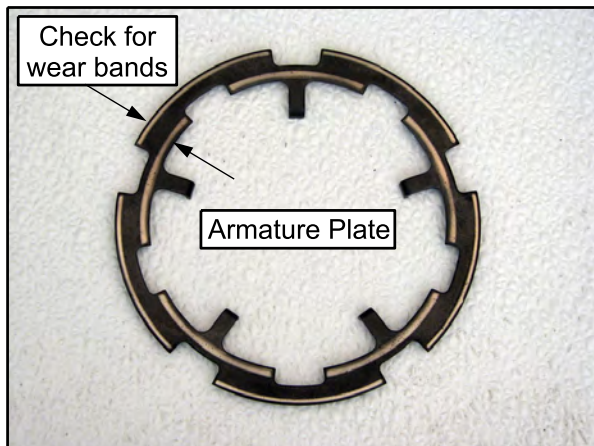

5. Check to make sure the coil is seated in the U-shaped insert that is pressed into the gearcase cover. The top of the coil should be seated below the U-shaped insert. The U-shaped insert controls the pole gap. If the top of the coil is above the surface of the U-shaped insert it raises the armature plate, thereby increasing pole gap. If the pole gap increases the coil will not be strong enough to engage the AWD system. If this is found, replace the cover plate assembly.

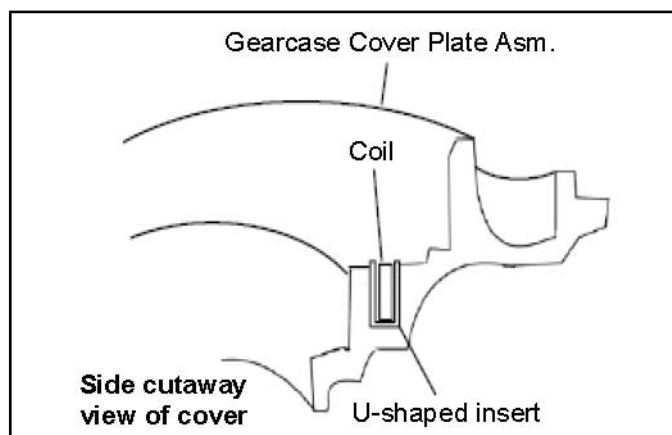

6. Inspect the rollers for nicks and scratches. The rollers must slide up, down, in and out freely within the roll cage sliding surfaces and H-springs.

7. Inspect the roll cage assembly for cracks or excessive wear. If damaged, replace the roll cage assembly.

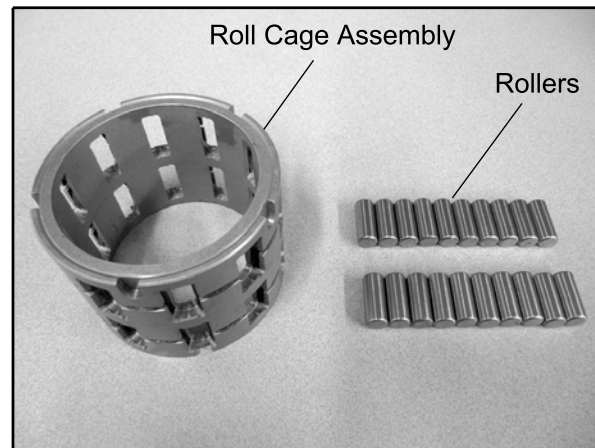

### Front Gearcase Removal

1. Raise and support vehicle
2. Place gear selector in neutral.
3. Refer to FRONT DRIVE SHAFT, page 7.6 and remove both front drive shafts from the front gearcase.
4. Remove the front section of the prop shaft (see "PROP SHAFT SERVICE").
5. Disconnect the wire harness for the front gearcase and remove the harness from the retaining dart.
6. Remove the vent line from the front gearcase and plug vent line fitting.
7. Remove the four bolts (Item 4) securing the front gearcase to the frame.

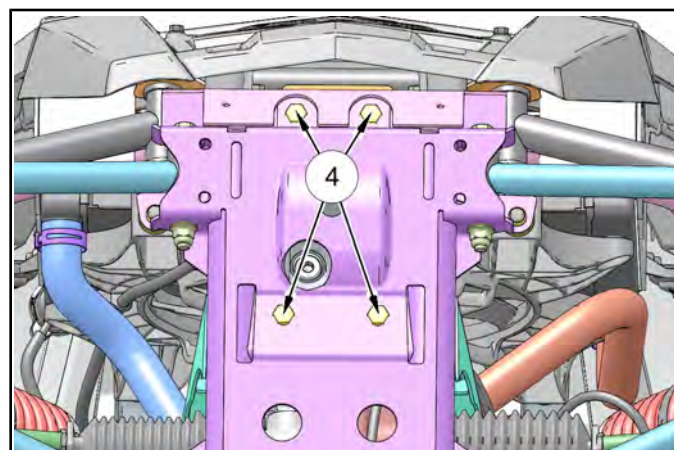

8. Rotate front of gearcase up so the input shaft is facing down. Lift and remove the gearcase from the front LH wheel well area and slide it out of the vehicle above the upper A-arm.

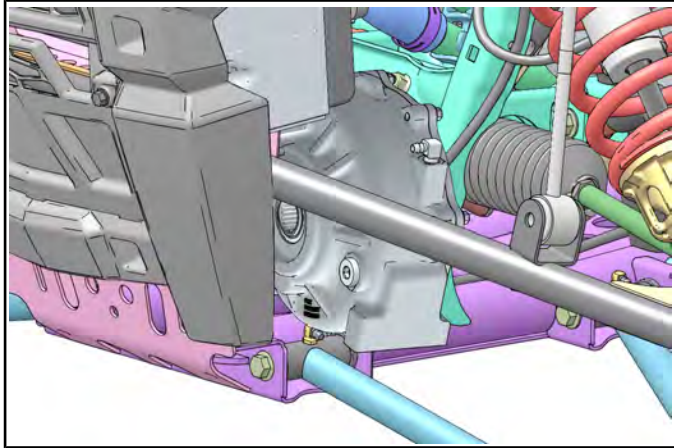

### Front Gearcase Disassembly / Inspection

1. Drain and properly dispose of gearcase fluid. Remove any metal particles from the drain plug magnet.
2. Remove the seven cover screws and remove the cover plate assembly.

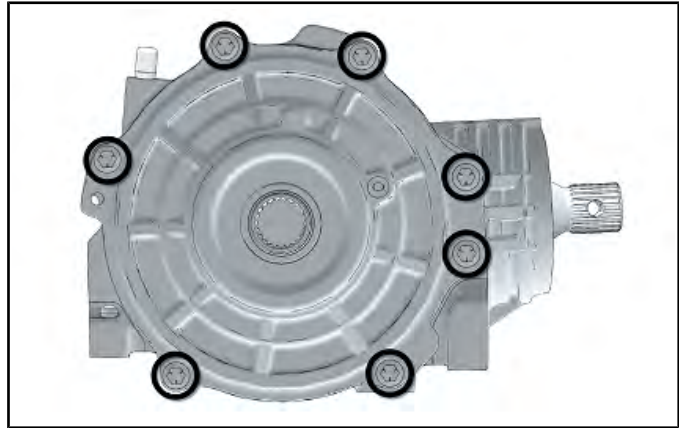

3. Remove the LH output hub assembly from the clutch housing or outer cover plate assembly.

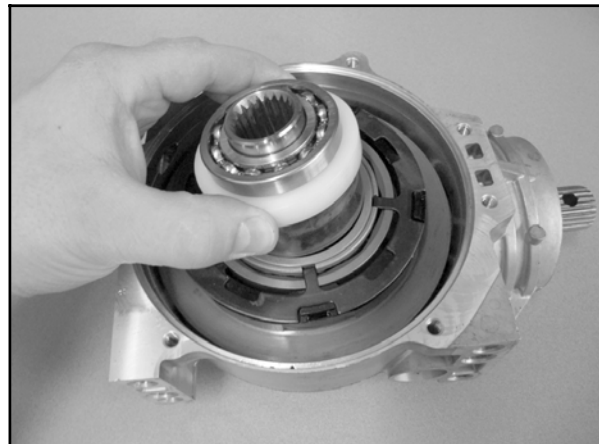

**NOTE: Nylon spacer is non-serviceable and should not be removed.**

## FINAL DRIVE

---

4. Remove and inspect the armature plate. Refer to "AWD Diagnosis" for detailed inspection process.

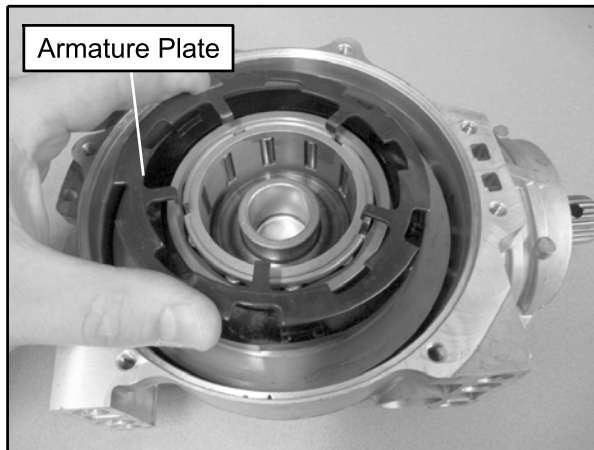

6. Remove the clutch housing / ring gear and roll cage assembly from the gearcase housing.

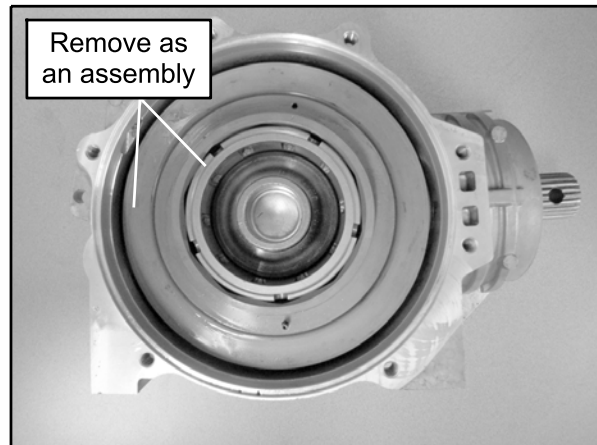

5. Remove the torsion spring retainer and torsion spring from the top of the ring gear.

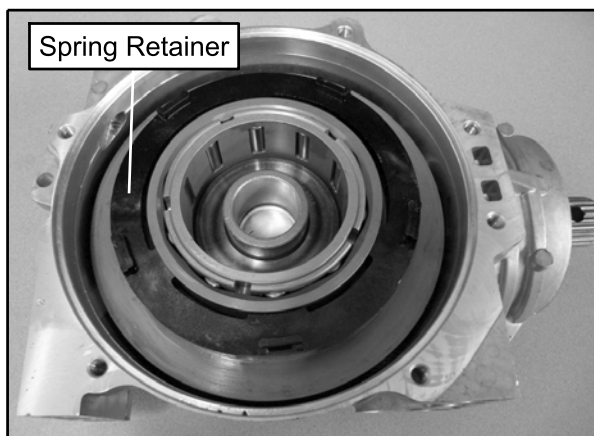

7. Remove the RH output hub assembly from the gearcase housing.

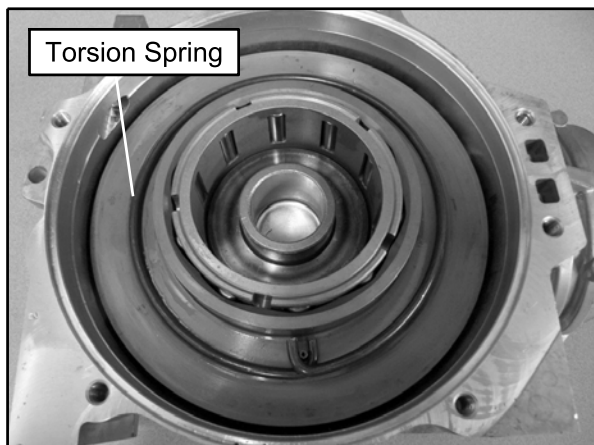

## FINAL DRIVE

8. Remove pinion seal, internal retaining ring and pinion gear assembly from the gearcase housing. Inspect and clean the gearcase housing and replace all oil seals and O-rings.

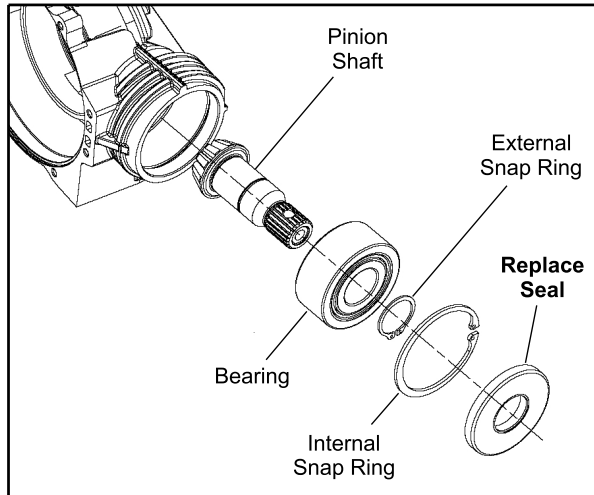

9. Inspect the pinion gear for chipped, broken or missing teeth. Inspect the pinion bearing for signs of wear and the pinion shaft seal surface for pitting.

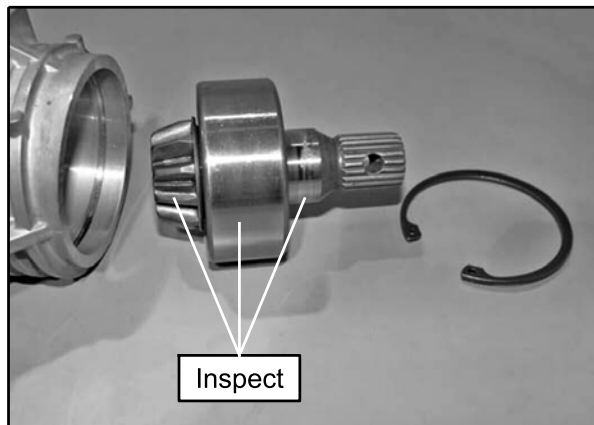

10. Inspect the AWD coil located in the outer cover plate assembly. Refer to "AWD Diagnosis" for detailed inspection process. Replace the cover plate seal and O-ring.

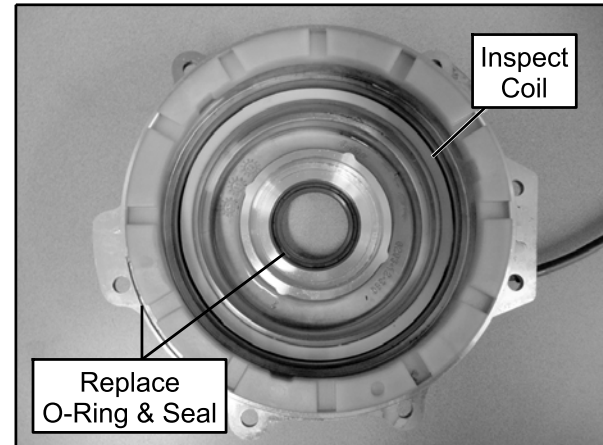

11. Remove the roll cage assembly and rollers from the clutch housing. Use a shop towel to cover the housing in order to retain all the rollers.

**NOTE: Rollers are spring loaded. Take care not to allow them to fall out or lose them upon removal of the roll cage.**

12. Thoroughly clean all parts and inspect the rollers (A) for nicks and scratches. The rollers must slide up and down and in and out freely within the roll cage (B) sliding surfaces and H-springs.

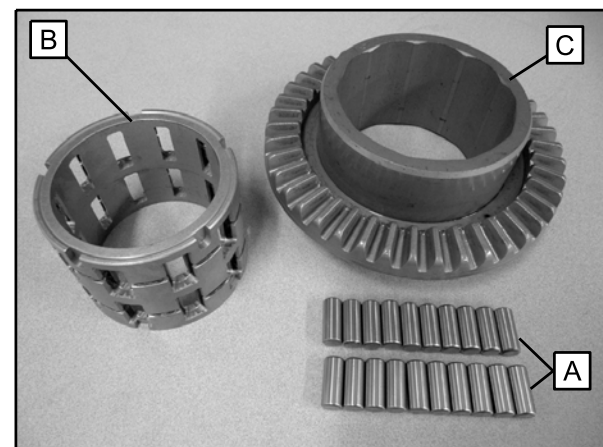

**NOTE: Refer to the "Electronic Parts Catalog" for individual part availability. Most parts are to be replaced as an assembly or as a complete kit.**

13. Inspect clutch housing / ring gear (C) for a consistent wear pattern. Inspect the ring gear for chipped, broken, or missing teeth.

7

7.21

## FINAL DRIVE

14. Inspect the roll cage assembly (B) sliding surfaces and H-springs. The sliding surfaces must be clean and free of nicks, burrs or scratches. If damaged, replace the roll cage assembly.

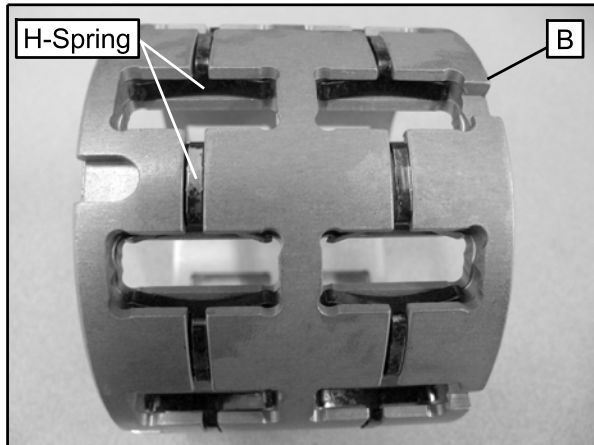

3. Install a new pinion shaft seal into the pinion gear housing. Using a universal seal installer, press the new seal into the housing until the seal is just below the housing chamfer.

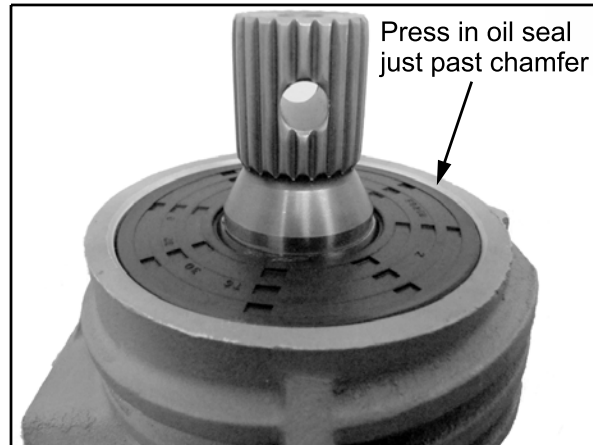

15. Inspect both output hub assemblies. Inspect the bearings and replace if needed.

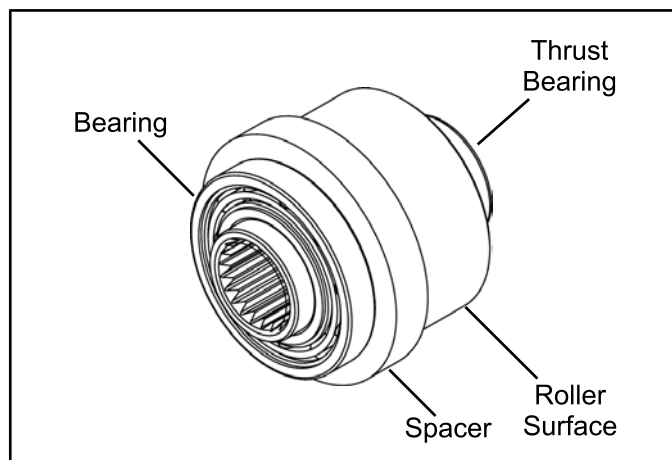

4. Install the RH output hub into the gearcase housing.

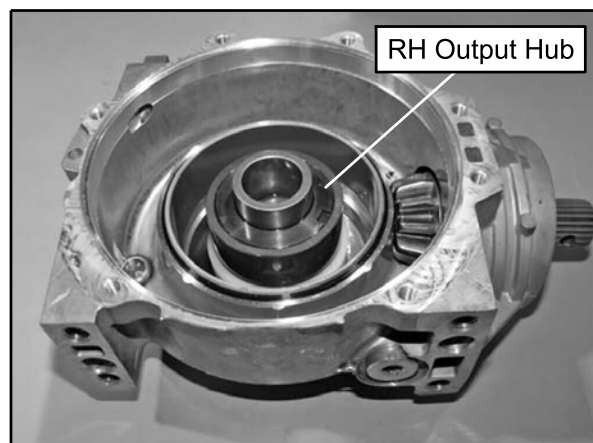

16. Clean and inspect all remaining front gearcase components. Check each for excessive wear or damage.

### Front Gearcase Assembly

1. As mentioned during gearcase disassembly section, replace all O-rings, seals and worn components.
2. Install pinion shaft assembly and install internal snap ring.

**NOTE:** If bearing replacement was required, press new bearing onto the pinion shaft and install a new external snap ring.

5. Carefully install the rollers into the roll cage assembly while installing the assembly into the clutch housing.

**NOTE:** Install roll cage so that the ring gear grooves line up with the roll cage windows (see below). Be sure roll cage top groove is facing upward.

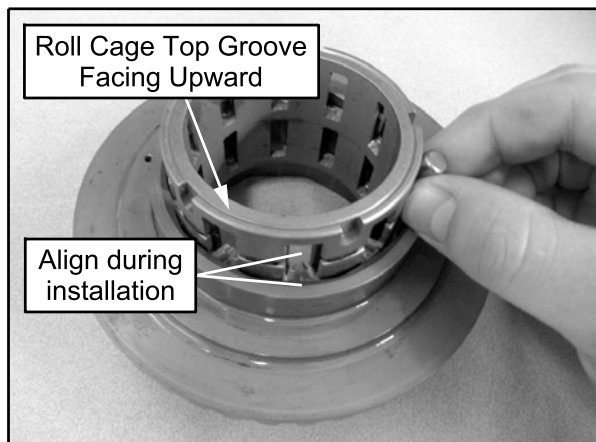

6. Install the torsion spring by wrapping each leg of the spring around the dowel pin on the ring gear.

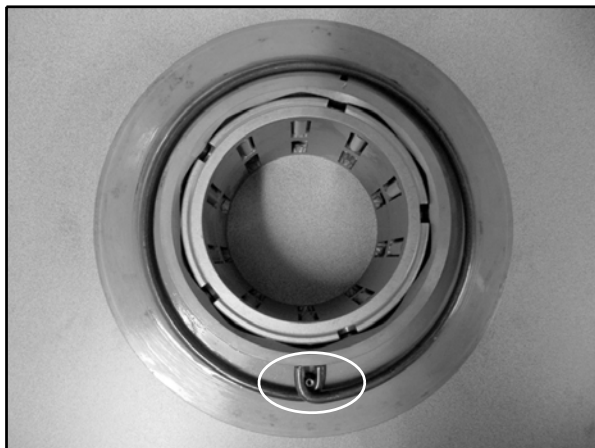

7. Align spring retainer dowel pin with ring gear dowel pin and install the retainer on top of the torsion spring.

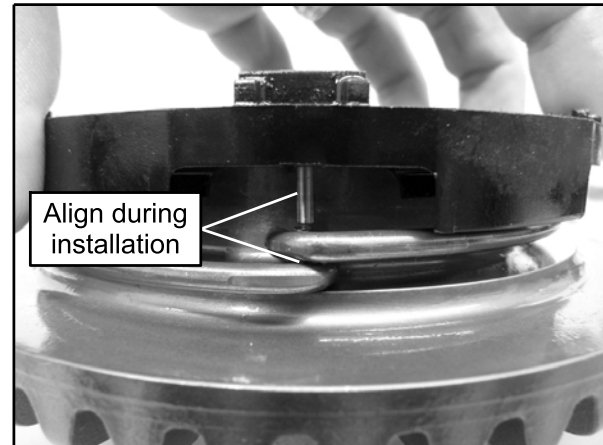

8. Check the action of the torsion spring by rotating in both directions to ensure the spring and retainer are installed properly.

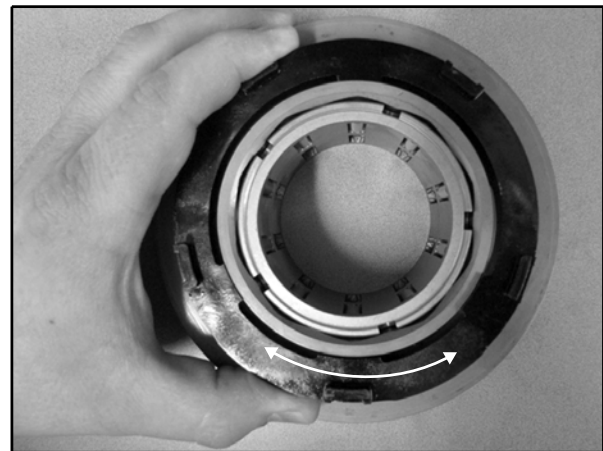



## FINAL DRIVE

9. Install armature plate. Be sure all of the armature plate tabs are fully engaged into the roll cage assembly and that it is resting properly on the torsion spring retainer.

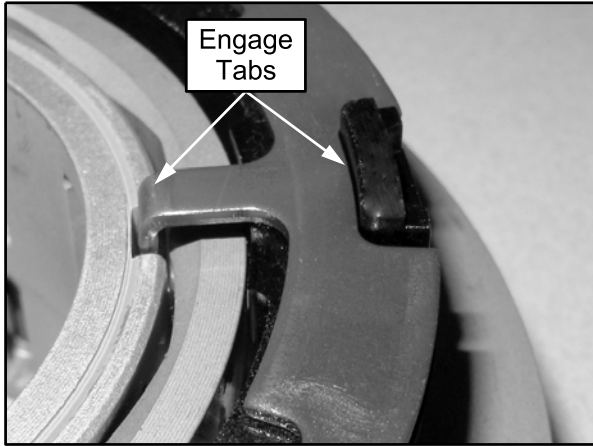

**NOTE:** Verify armature plate tabs are in the roll cage slots and that it rests properly on the spring retainer.

10. Carefully install the ring gear and roll cage assembly into the gearcase housing.

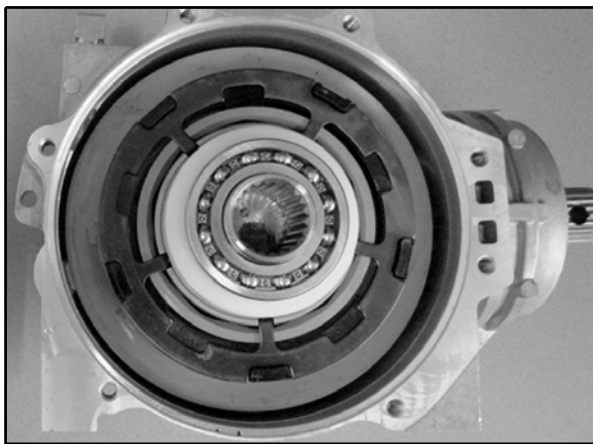

11. Install a new O-ring on the cover plate assembly.

**NOTE:** Be sure the square O-ring is placed flat on the cover surface. If the O-ring is twisted fluid leakage may occur.

12. Carefully install the LH output hub assembly into the cover plate. Take care not to damage the new cover plate seal while installing the output hub.

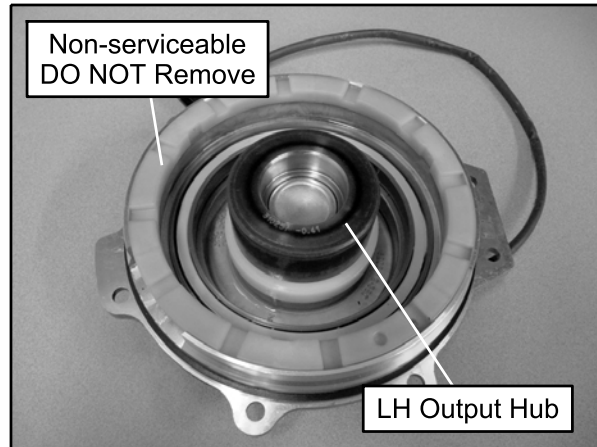

13. Install the output cover assembly onto the gearcase housing. Install the seven cover plate screws and torque to specification.

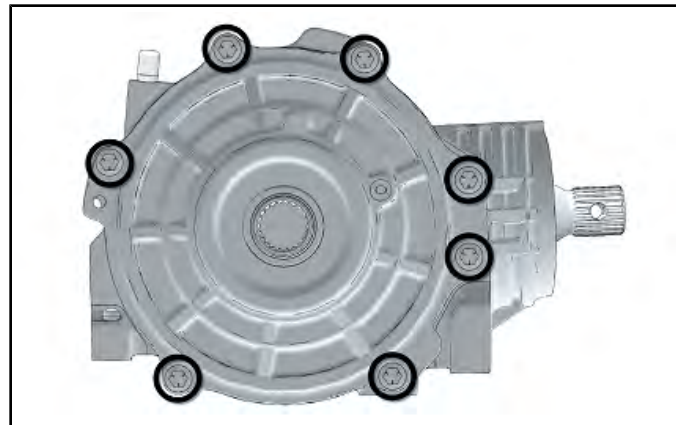

Cover Plate Screws:  
11 ft-lbs (15 Nm)

## Front Gearcase Installation

1. Install the gearcase back into the vehicle through the LH wheel well area, above the upper A-arm.

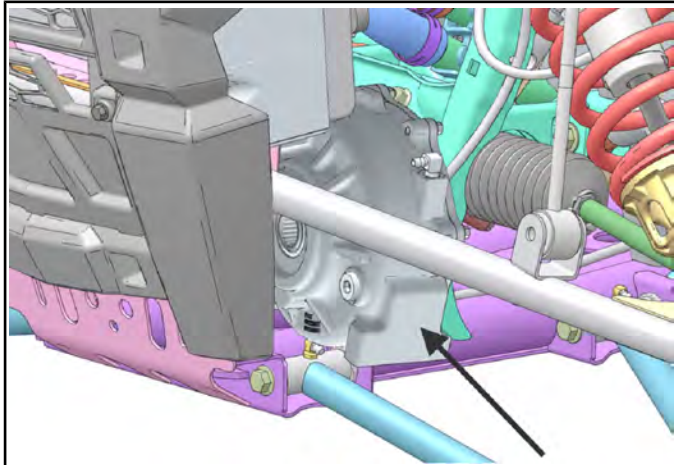

2. Lubricate the front gearcase splines with Anti-Seize.
3. Install the prop shaft onto the front gearcase input shaft. Use a NEW spring pin in the front propshaft.
4. Install the four bolts (Item 1) that secure the front gearcase to the frame and torque to specification.



Front Gearcase Mounting Bolts:  
**30 ft-lbs (41 Nm)**

5. Install the vent line (Item 2).

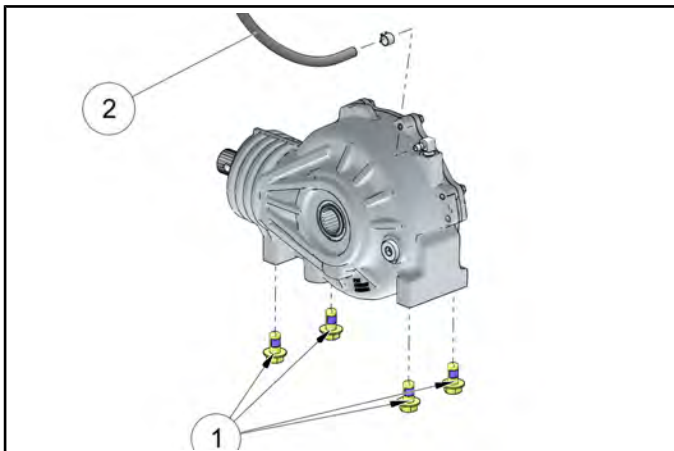

6. Connect the AWD wire harness.

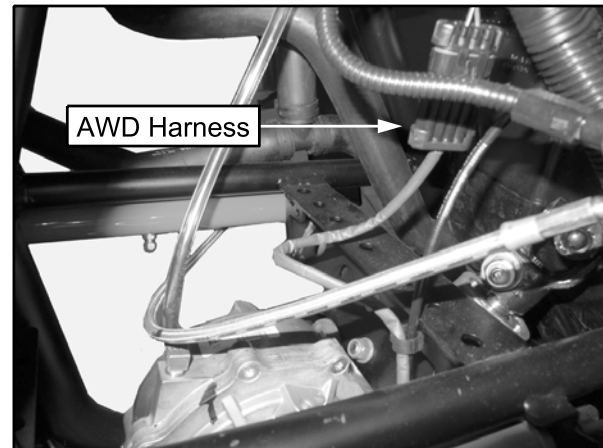

7. Refer to "FRONT DRIVE SHAFT - Drive Shaft Installation" and install both front drive shafts into the gearcase.
8. Add the proper lubricant to the front gearcase. Refer to Chapter 2 for fluid fill and change information.

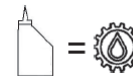

**Recommended Front Gearcase Fluid:**  
Polaris Demand Drive  
(PN 2877922) (Quart)

**Capacity:** □ 8.5 oz. (250 ml)  
(fill on a level surface to bottom of threads on the fill hole)

# FINAL DRIVE

## REAR BEARING CARRIER

### Bearing Carrier Inspection / Removal

1. Elevate rear of vehicle and safely support machine under the frame area.

#### CAUTION

Serious injury may result if machine tips or falls. Be sure machine is secure before beginning this service procedure. Wear eye protection when removing bearings and seals.

2. Check bearings for side play by grasping the top and bottom of the tire firmly and checking for movement. The tire should rotate smoothly without binding or rough spots.
3. Remove the four wheel nuts and rear wheel.
4. Remove the cotter pin (Item 1) and loosen the rear wheel hub castle nut (Item 2). Remove the nut, and (2) cone washers (Item 3) from the rear wheel hub assembly.

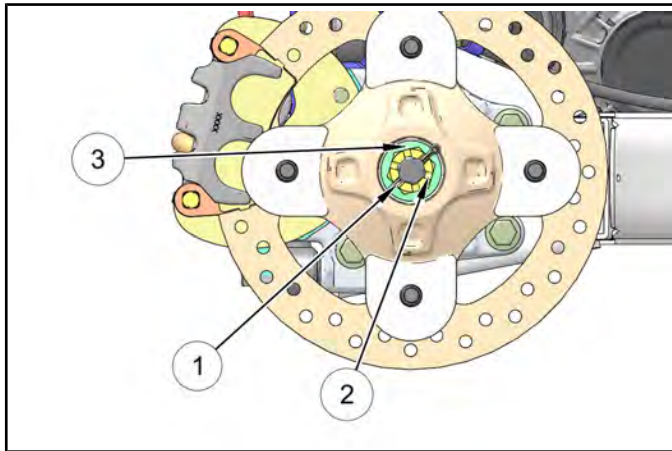

5. Remove the lower radius rod outer mounting bolt (Item 4), nut and washer from the bearing carrier. Swing radius rod down. Discard the nut.

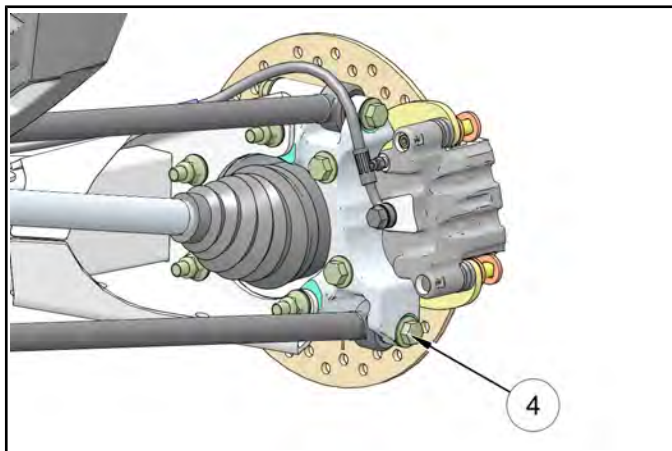

6. Remove the two brake caliper mounting bolts (Item 5). Remove the rear brake caliper assembly.
7. **CAUTION:** Do not hang the caliper by the brake line. Use wire to hang caliper to prevent damage to the brake line.

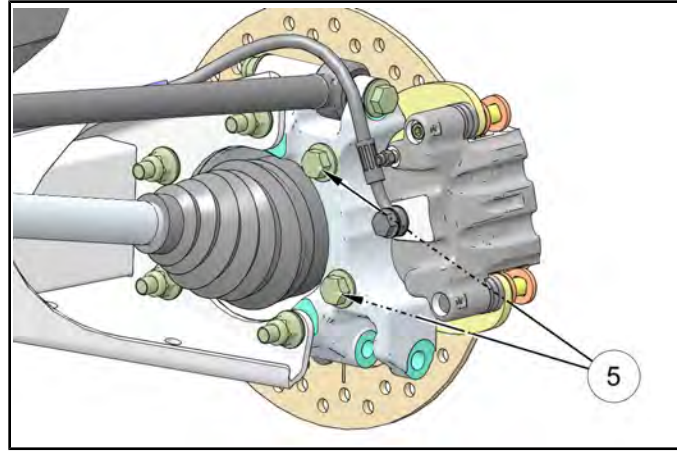

8. Remove the rear wheel hub and brake disk assembly.
9. Remove the five remaining bolts (Item 6) that attach the rear bearing carrier to the trailing arm. Discard the nuts.

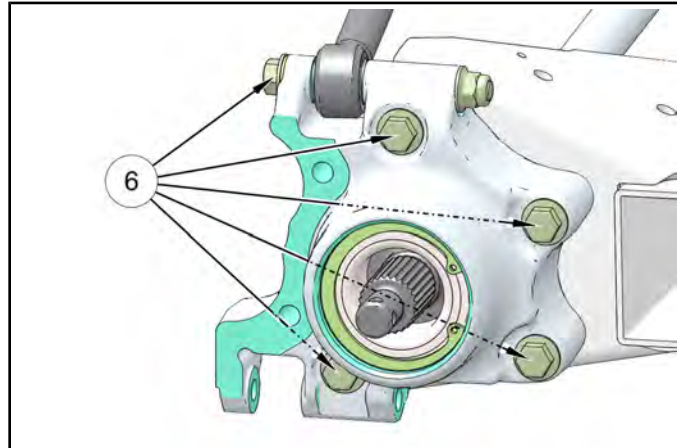

10. Remove the bearing carrier from the rear drive shaft and trailing arm.

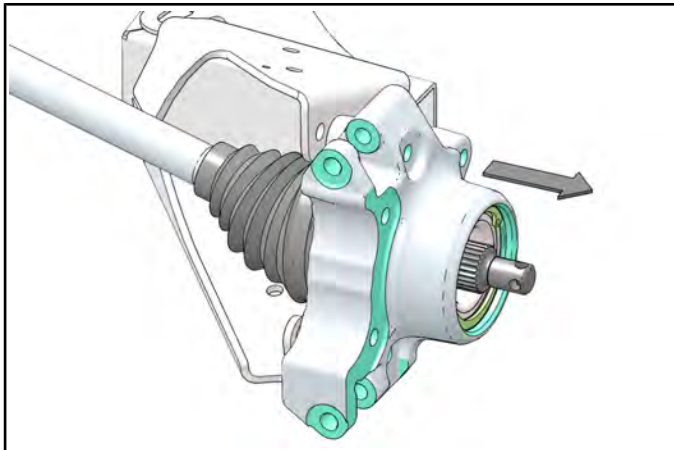

11. Rotate bearing by hand and check for smooth rotation. Visually inspect bearing for moisture, dirt, or corrosion.

**NOTE:** Due to extremely close tolerances and minimal wear, the bearings must be inspected visually, and by feel. While rotating bearings by hand, inspect for rough spots, discoloration, or corrosion. The bearings should turn smoothly and quietly, with no detectable up and down movement and minimal movement sideways between inner and outer race.

12. Replace bearing if moisture, dirt, corrosion, or roughness is evident.

## Bearing Replacement

### Bearing Removal

1. Remove the outer snap ring (Item 1).

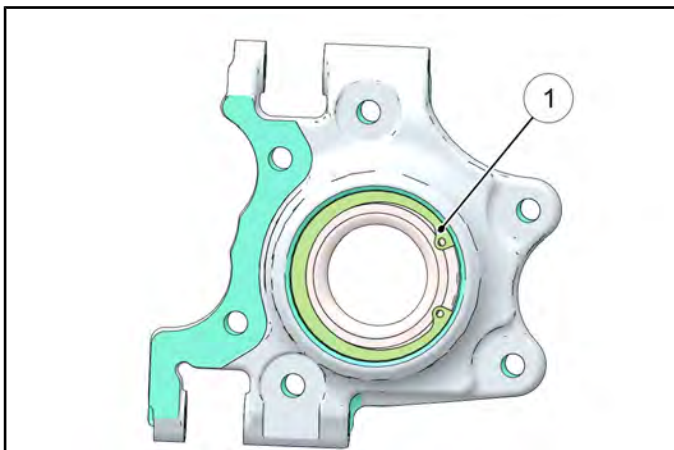

2. From the back side of the bearing carrier, tap on the outer bearing race with a drift punch in the reliefs as shown.

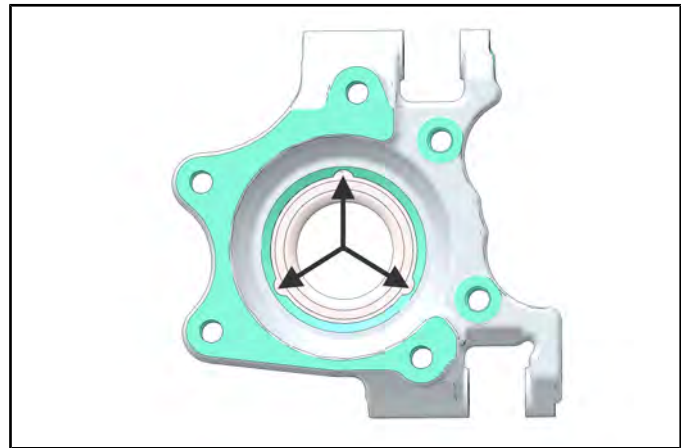

3. Drive bearing out evenly by tapping on outer race only. Once bearing is at bottom of casting, support casting on outer edges so bearing can be removed.
4. Inspect the bearing carrier housing for scratches, wear or damage. Replace rear bearing carrier if damaged.

### Bearing Installation

5. Thoroughly clean the rear bearing carrier housing and the outer race on the new bearing. Be sure that all oil residue has been removed from each surface.
6. Support the bottom of the bearing carrier housing.

### CAUTION

Use an arbor and press only on the outer race, otherwise bearing damage may occur.

## FINAL DRIVE

7. Apply **Loctite® 603™** retaining compound to the outer circumference of the new bearing race (Item 2) and carefully press the new bearing into the bearing carrier housing (Item 3).

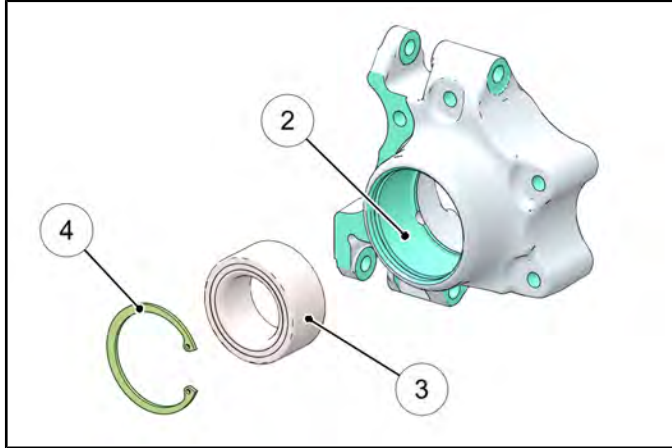

**NOTE:** Use care to not allow any of the Loctite® compound to get in the bearing.

8. Wipe the housing clean of any excess compound and install the snap ring (Item 4).

### Bearing Carrier Installation

1. Install drive shaft through the backside of the bearing carrier.

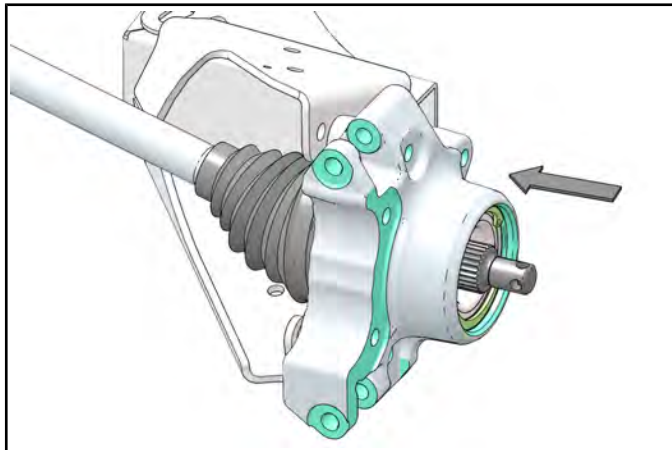

2. Install the four fasteners (Item 1) that attach the rear bearing carrier to the trailing arm. Install the (1) fastener (Item 2) that attaches the upper radius rod to the bearing carrier. Torque bolts to specification.

**NOTE:** Use new nuts upon installation of the rear bearing carrier.

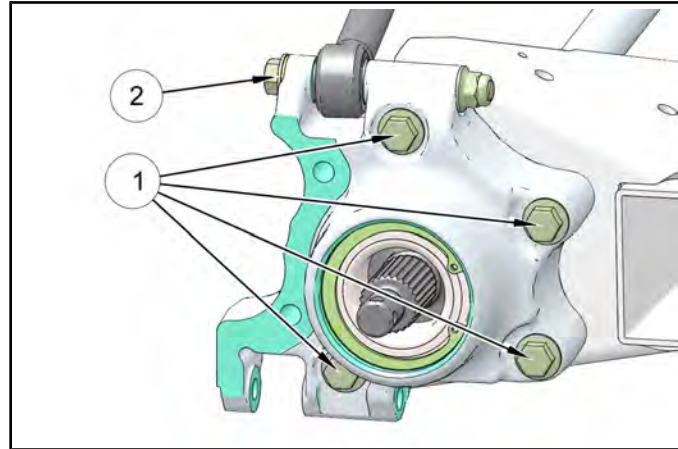

Bearing Carrier to Trailing Arm Bolts:  
**42 ft-lb (54 Nm)**

Radius Rod to Bearing Carrier Fasteners:  
**40 ft-lb (54 Nm)**

3. Apply anti-seize to drive shaft splines.
4. Install rear wheel hub assembly (Item 2), cone washers (Item 3), and hand tighten the castle nut. Install washers with domed side out.

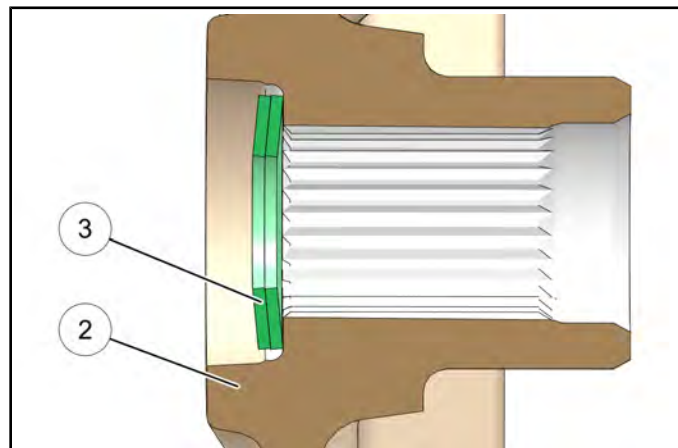

# FINAL DRIVE

5. Install the rear brake caliper assembly and new bolts (Item 4). Torque to specification.

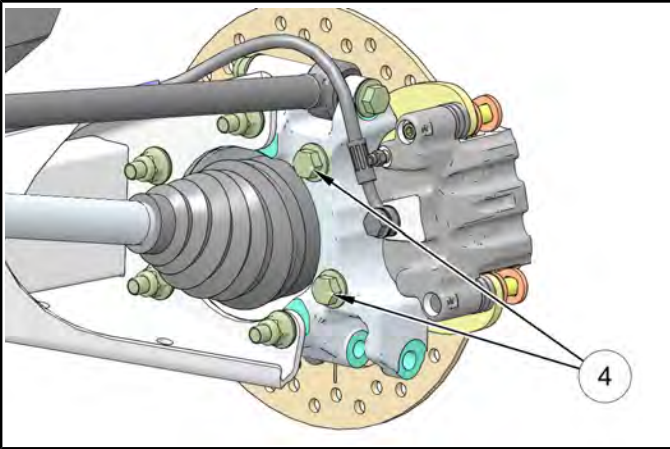

 = T

Rear Caliper Mounting Bolts:  
**40 ft-lbs (54 Nm)**

6. Torque wheel hub nut to specification and install a **new** cotter pin (Item 5). Tighten nut slightly if necessary to align cotter pin holes.

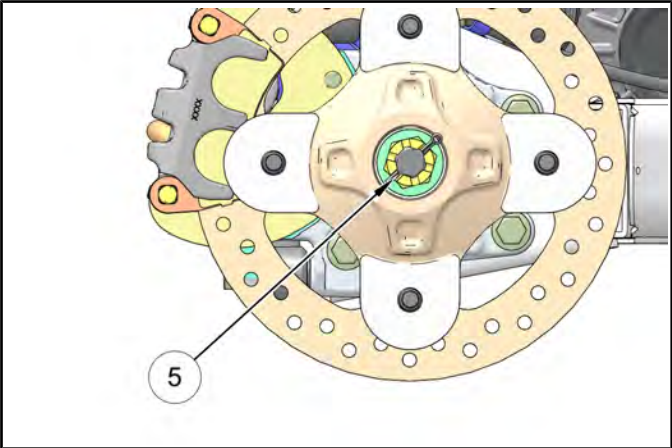

 = T

Hub Castle Nut:  
**110 ft-lbs (149 Nm)**

7. Install wheel and (4) wheel nuts. Torque wheel nuts to specification.

 = T

Wheel Nuts:  
**120 ft-lbs (163 Nm)**

8. Rotate wheel and check for smooth operation. Bend both ends of cotter pin around end of spindle in different directions.

7

# FINAL DRIVE

## REAR DRIVE SHAFT

### Drive Shaft Removal

1. Raise and support the vehicle.

#### CAUTION

Serious injury may result if machine tips or falls. Be sure machine is secure before beginning this procedure. Always wear eye protection.

2. Remove the four wheel nuts and rear wheel.
3. Remove the cotter pin (Item 1) and loosen the rear wheel hub castle nut (Item 2). Remove the nut, and (2) cone washers (Item 3) from the rear wheel hub assembly.

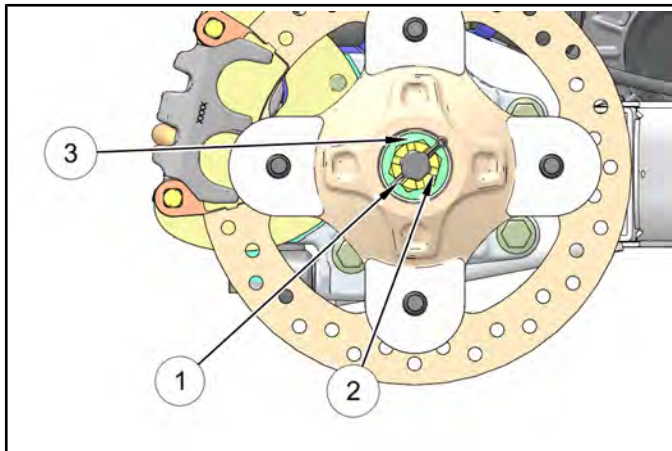

4. Remove the two bolts (Item 4) retaining the upper and lower radius rods to the bearing carrier. Discard the nuts. Let the radius rods swing downward.
5. Remove the brake caliper mounting bolts (Item 5). Remove the rear brake caliper assembly.
6. **CAUTION:** Do not hang the caliper by the brake line. Use wire to hang caliper to prevent damage to the brake line.

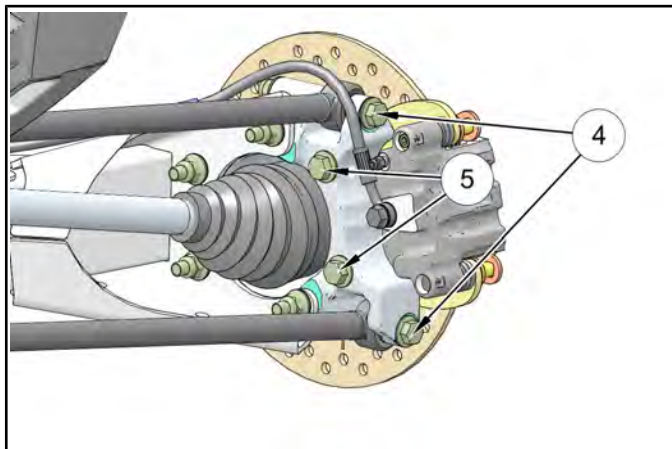

7. Remove the rear hub assembly from the bearing carrier.
8. Support the trailing arm from underneath.
9. Remove the lower shock mounting bolt and nut (Item 6). Swing the shock inward. Discard the nut.
10. Remove the stabilizer bar mounting bolt, washer and nut (Item 7). Discard the nut.
11. Lift the trailing arm assembly upward so the rear drive shaft is parallel with the ground.
12. Leaving the drive shaft in the transmission, swing the rear trailing arm assembly outward until it is free from the rear drive shaft.
13. Lower the trailing arm.

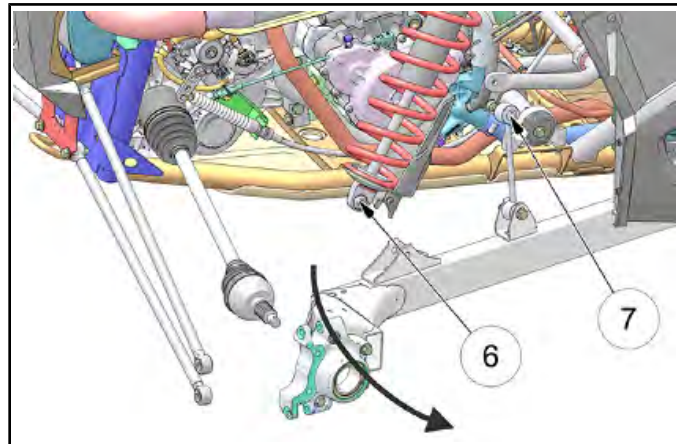

14. With a short, sharp jerk, remove drive shaft from the transmission splines.

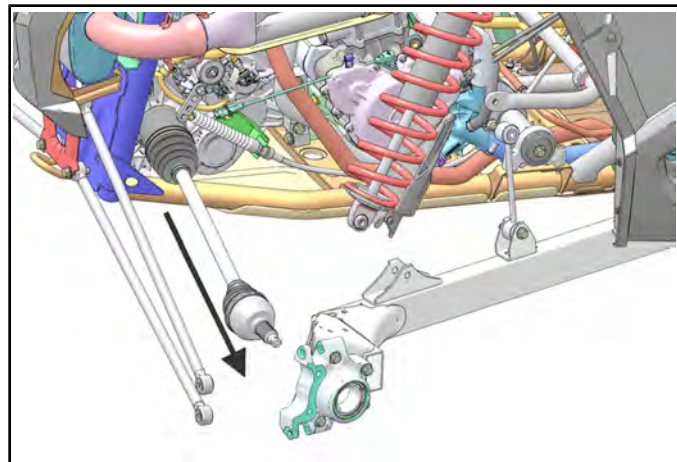

## Drive Shaft Installation

1. Install **new** spring ring (Item 1) on drive shaft. Apply an anti-seize compound to the splines (Item 2).

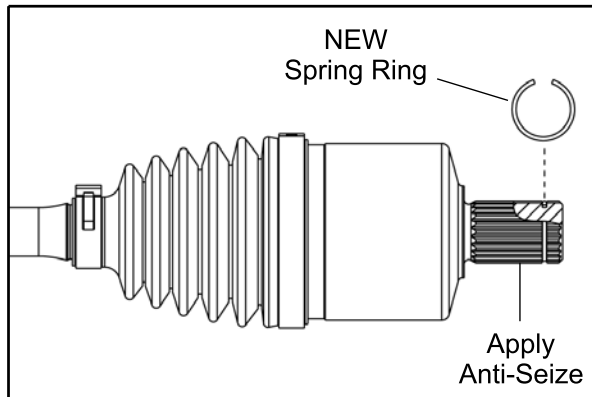

2. Align splines of drive shaft with transmission splines and reinstall the drive shaft. Use a rubber mallet to tap on the outboard end of the drive shaft if necessary.

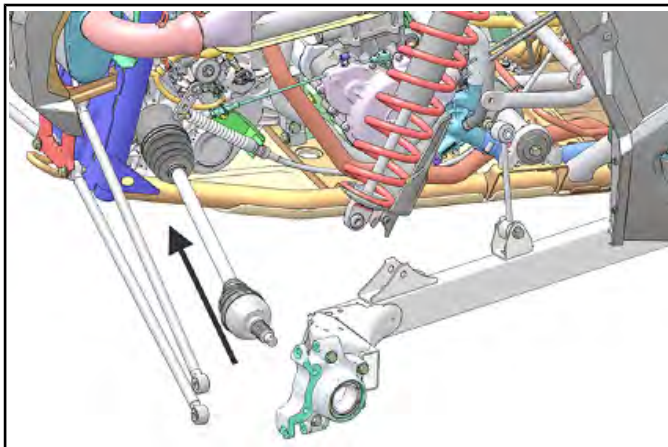

3. Swing the rear trailing arm assembly outward and upward until the rear axle can be inserted into the bearing carrier. Support the trailing arm from underneath.

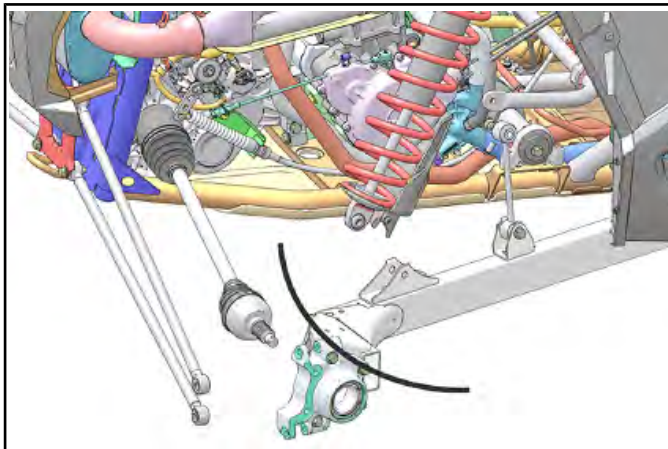

4. Install the lower shock mounting bolt and **new** nut. Torque fastener to specification.



Lower Shock Bolt to Trailing Arm:  
**70 ft-lbs (95 Nm)**

5. Install the stabilizer bar mounting bolt, washer and **new** nut. Torque fastener to specification.



Stabilizer Bar Linkage:  
**40 ft-lbs (54 Nm)**

6. Apply Anti-Seize to drive shaft axle splines.



# FINAL DRIVE

7. Install rear wheel hub assembly (Item 3). Install the two cone washers (Item 4) and castle nut. Torque castle nut to specification. Install new cotter pin (Item 5).

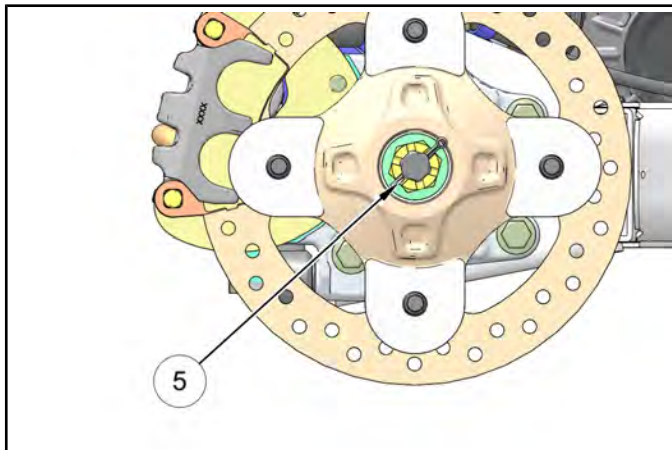
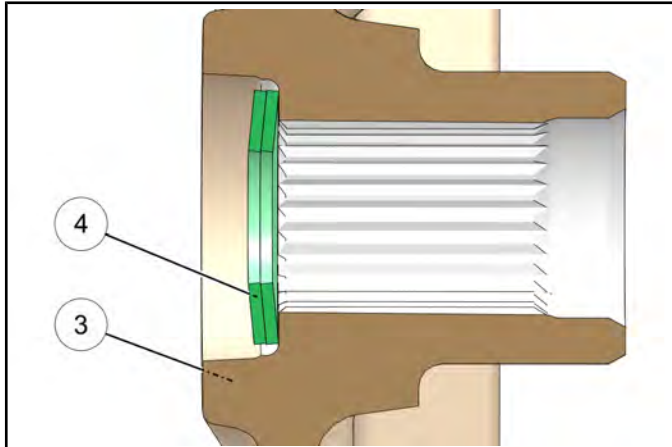

 = T

**Rear Hub Castle Nut:  
110 ft-lbs (149 Nm)**

8. Install the radius rod bolts, washers and **new** nuts. Torque fasteners to specification.

 = T

**Radius Rods to Bearing Carrier:  
40 ft-lb (54 Nm)**

9. Install the rear brake caliper assembly and **new** bolts (Item 6). Torque to specification.

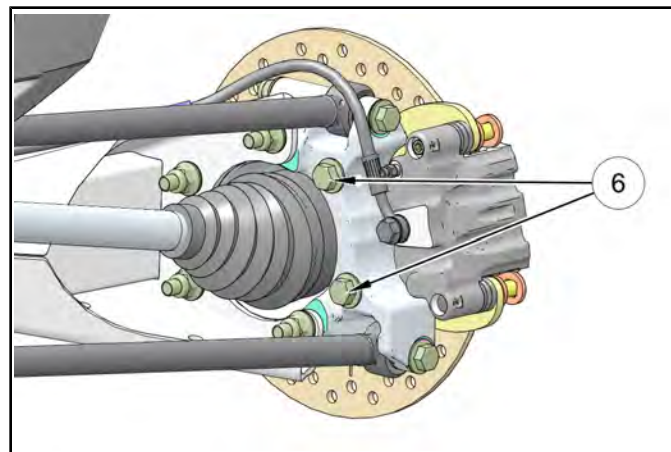

 = T

**Rear Caliper Mounting Bolts:  
40 ft-lbs (54 Nm)**

10. Install wheel and (4) wheel nuts. Torque wheel nuts to specification.

 = T

**Wheel Nuts:  
120 ft-lbs (163 Nm)**

## DRIVE SHAFT CV JOINT / BOOT REPLACEMENT

### Drive Shaft / CV Joint Handling Tips

Care should be exercised during drive shaft removal or when servicing CV joints. Drive shaft components are precision parts.

Cleanliness and following these instructions is very important to ensure proper shaft function and a normal service life.

- The complete drive shaft and joint should be handled by getting hold of the interconnecting shaft to avoid disassembly or potential damage to the drive shaft joints.
- Over-angling of joints beyond their capacity could result in boot or joint damage.
- Make sure surface-ground areas and splines of shaft are protected during handling to avoid damage.
- Do not allow boots to come into contact with sharp edges or hot engine and exhaust components.
- The drive shaft is not to be used as a lever arm to position other suspension components.
- Never use a hammer or sharp tools to remove or to install boot clamps.
- Be sure joints are thoroughly clean and that the proper amount and type of grease is used to refill when joint boots are replaced and when joints are cleaned. Refer to text for grease capacity of CV joints and CV joint boots.

### Outer CV Joint / Boot Replacement

1. Use a side cutters to cut and discard the boot clamps.

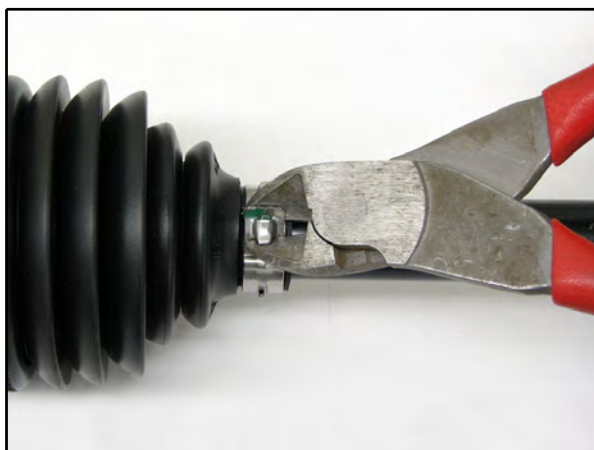

2. Remove the large end of the boot from the CV joint and slide the boot down the shaft.

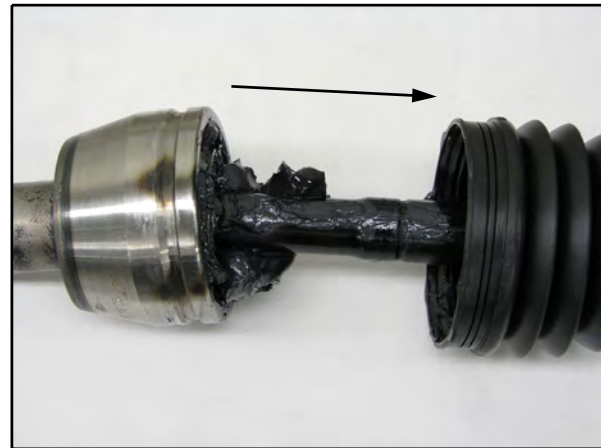

3. Clean the grease from the face of the joint.
4. Place the drive shaft in a soft-jawed vise. Using a soft-faced hammer, or brass drift (Item 1), strike the inner race of the joint to drive the joint off the drive shaft. Be sure to tap evenly around the joint to avoid binding.

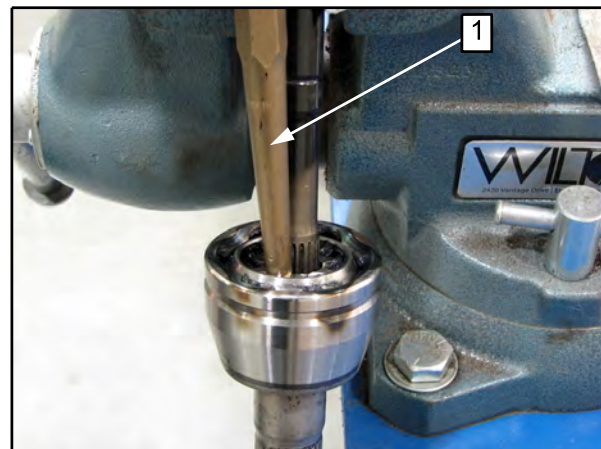

**NOTE: Tap on inner race only!**

7

## FINAL DRIVE

5. Make sure circlip (Item 2) is on the shaft and not left in the joint.

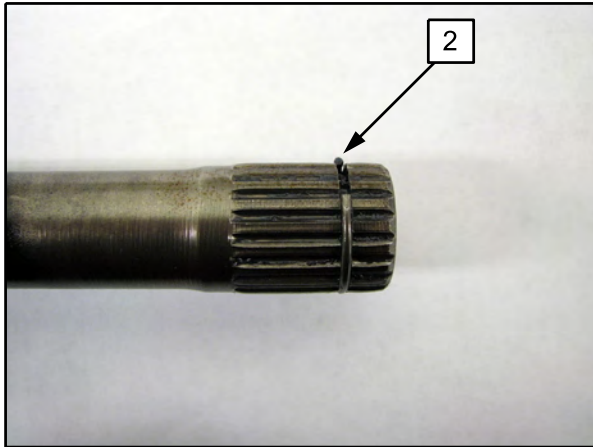

6. Remove the CV boot from the shaft.

### CAUTION

Complete disassembly of the CV joint is NOT recommended. The internal components are precision fit and develop their own characteristic wear patterns. Intermixing the internal components could result in looseness, binding, and/or premature failure of the joint.

**NOTE: If the grease in the joint is obviously contaminated with water and/or dirt, the joint should be replaced.**



7. Thoroughly clean the joint with an appropriate solvent and dry the joint to prevent any residual solvent from being left in the joint upon reassembly.

8. Visually inspect the joint by tilting the inner race to one side to expose each ball. Severe pitting, galling, play between the ball and its cage window, any cracking or damage to the cage, pitting or galling or chips in raceways call for joint replacement.

**NOTE: Shiny areas in ball tracks and on the cage spheres are normal. Do not replace CV joints because parts have polished surfaces. Replace CV joint only if components are cracked, broken, worn or otherwise unserviceable.**

9. Clean the splines on the end of the shaft and apply a light coat of grease prior to reassembly.
10. Slide the small boot clamp and boot (small end first) onto the drive shaft and position the boot in its groove machined in the shaft.
11. Install a **new** circlip on the end of the shaft.
12. Grease the joint with the special CV joint grease provided in the boot replacement kit. Fill the cavity behind the balls and the splined hole in the joint's inner race. Pack the ball tracks and outer face flush with grease. Place any remaining grease into the boot.

### CAUTION

The grease provided in the replacement kit is specially formulated for wear resistance and durability. DO NOT use substitutes or mix with other lubricants.

**NOTE: The amount of grease provided in the boot kit is pre-measured. Use entire contents of package.**

13. Slide the joint onto the drive shaft splines and align the circlip with the lead-in chamfer on the inner race of the joint.



14. Use a soft-faced hammer to tap the joint onto the drive shaft until it locks into place.
15. Pull on the joint to make sure it is securely locked in place.
16. Remove excess grease from the CV joint's external surfaces and place the excess grease in the boot.
17. Pull the boot over the joint and position the boot lips into the grooves on the joint housing and shaft. Make sure the boot is not dimpled or collapsed.
18. Install and tighten the large clamp using the appropriate clamp tool.



**Axle Boot Clamp Tool: PU-48951  
or  
CV Boot Clamp Pliers: 8700226**

19. While pulling out on the CV shaft, fully extend the CV joint and slide a straight O-ring pick or a small slotted screw driver between the small end of the boot and the shaft. This will allow the air pressure to equalize in the CV boot in the position that the joint will spend most of its life. Before you remove your instrument, be sure the small end of the boot is in its correct location on the shaft.

20. Install and tighten the small clamp on the boot using the appropriate clamp tool.



**Axle Boot Clamp Tool: PU-48951  
or  
CV Boot Clamp Pliers: 8700226**

### Inner Plunging Joint / Boot Replacement

1. Use a side cutters to cut and discard the boot clamps

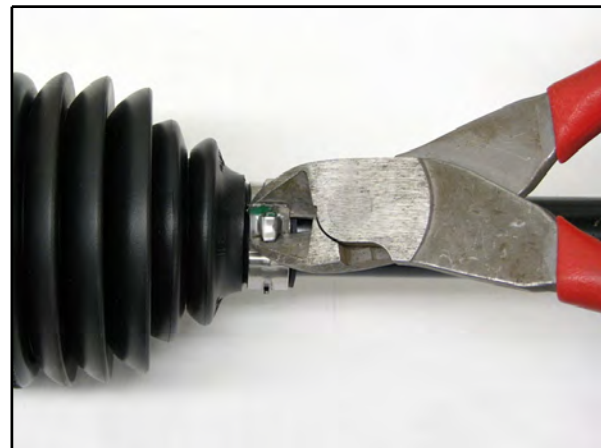

## FINAL DRIVE

2. Remove the large end of the boot from the plunging joint and slide the boot down the shaft.

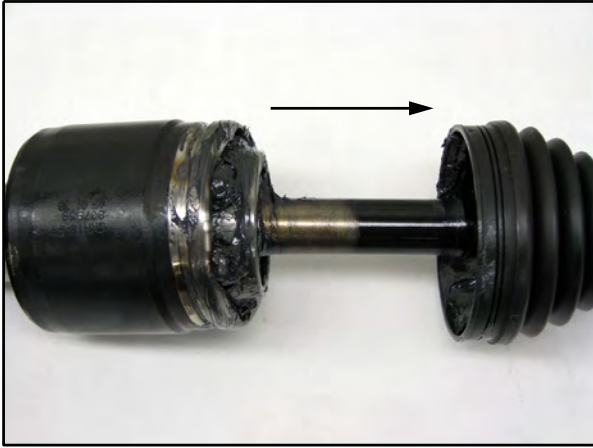

5. Make sure the circlip (Item 2) is on the shaft and not left in the joint.

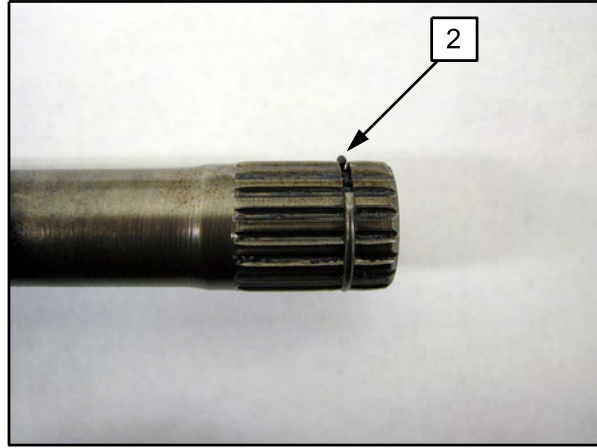

3. Clean the grease from the face of the joint and place the drive shaft in a soft-jawed vise.
4. Using a soft-faced hammer, or brass drift (Item 1), strike the inner race of the joint to drive the joint off the shaft. Be sure to tap evenly around the joint to avoid binding.

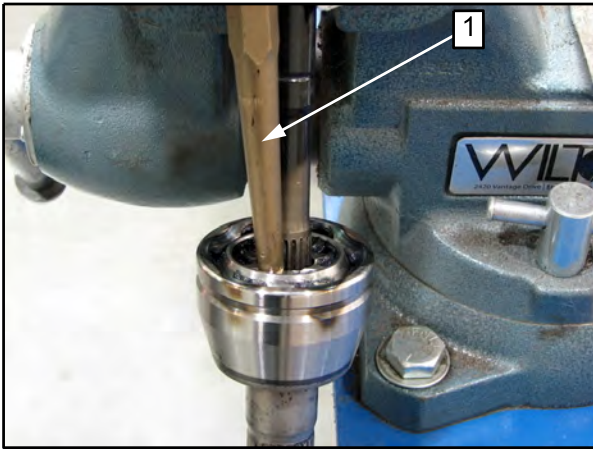

**NOTE: Tap on inner race only!**

6. Remove the boot from the shaft.

### CAUTION

Complete disassembly of the plunging joint is NOT recommended. The internal components are precision fit and develop their own characteristic wear patterns. Intermixing the internal components could result in looseness, binding, and/or premature failure of the joint.

**NOTE: If the grease in the joint is obviously contaminated with water and/or dirt, the joint should be replaced.**



7. Thoroughly clean the joint with an appropriate solvent and dry the joint to prevent any residual solvent from being left in the joint upon reassembly.
8. Visually inspect the joint for damage. Replace if needed.

9. Clean the splines on the end of the shaft and apply a light coat of grease prior to reassembly.
10. Slide the small boot clamp and boot (small end first) onto the drive shaft and position the boot in its groove machined in the shaft.
11. Install a **new** circlip on the end of the shaft.
12. Grease the joint with the special joint grease provided in the boot replacement kit. Fill the cavity behind the balls and the splined hole in the joint's inner race. Pack the ball tracks and outer face flush with grease. Place any remaining grease into the boot.

### CAUTION

The grease provided in the replacement kit is specially formulated for wear resistance and durability. **DO NOT** use substitutes or mix with other lubricants.

**NOTE:** The amount of grease provided in the boot kit is pre-measured. Use entire contents of package.

13. Fully compress the joint and push the drive shaft firmly into the inner race.
14. Align the circlip with the lead-in chamfer.



15. Use a soft-faced hammer to tap the joint onto the drive shaft until you reach the end of the splines and the joint locks in place.
16. Pull on the joint to test that the circlip is seated and that the joint is securely fastened to the shaft.
17. Remove excess grease from the plunging joint's external surfaces and place the excess grease in the boot.

18. Pull the boot over the joint and position the boot lips into the grooves on the joint housing and shaft. Make sure the boot is not dimpled or collapsed.
19. Install and tighten the small clamp using the appropriate clamp tool.



**Axle Boot Clamp Tool: PU-48951  
or  
CV Boot Clamp Pliers: 8700226**

20. Pull out on the drive shaft to center the joint in the housing. Slide a straight O-ring pick or a small slotted screw driver between the large end of the boot and the joint housing and lift up to equalize the air pressure in the boot.
21. Position the boot lip in its groove. Install and tighten the large clamp using the appropriate clamp tool.



**Axle Boot Clamp Tool: PU-48951  
or  
CV Boot Clamp Pliers: 8700226**

# FINAL DRIVE

## Drive Shaft Assembly View

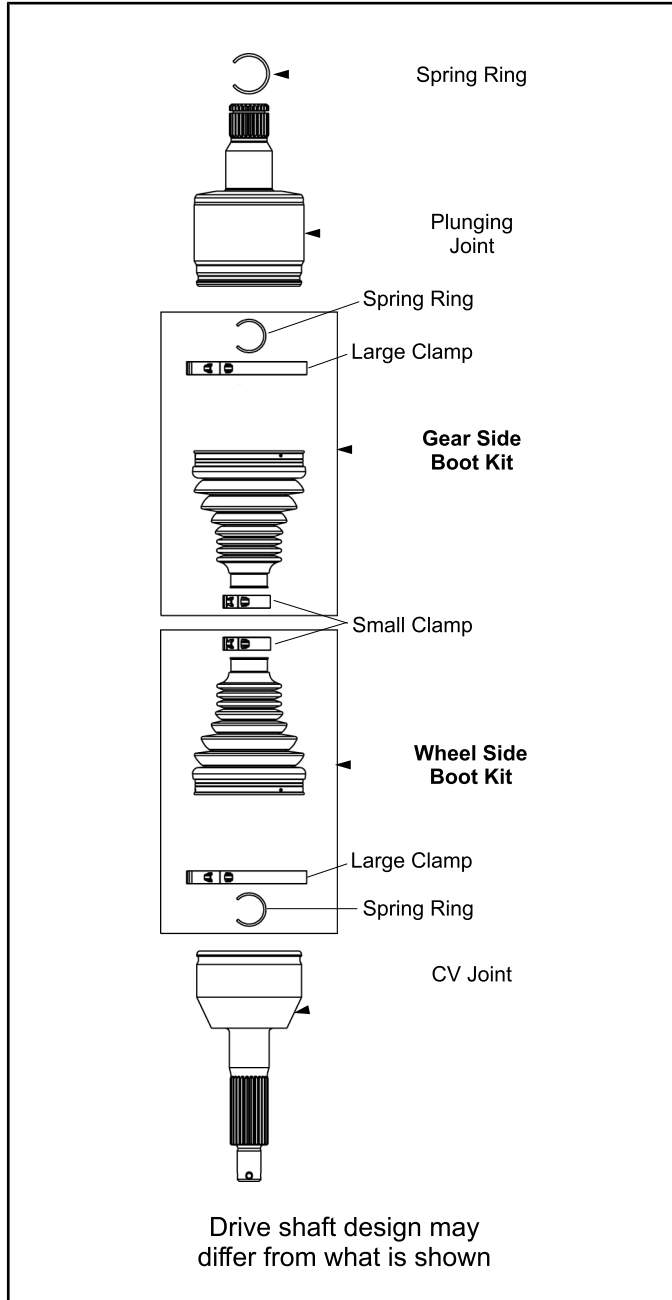

**WHEEL HUBS**

**Front Hub Assembly View**

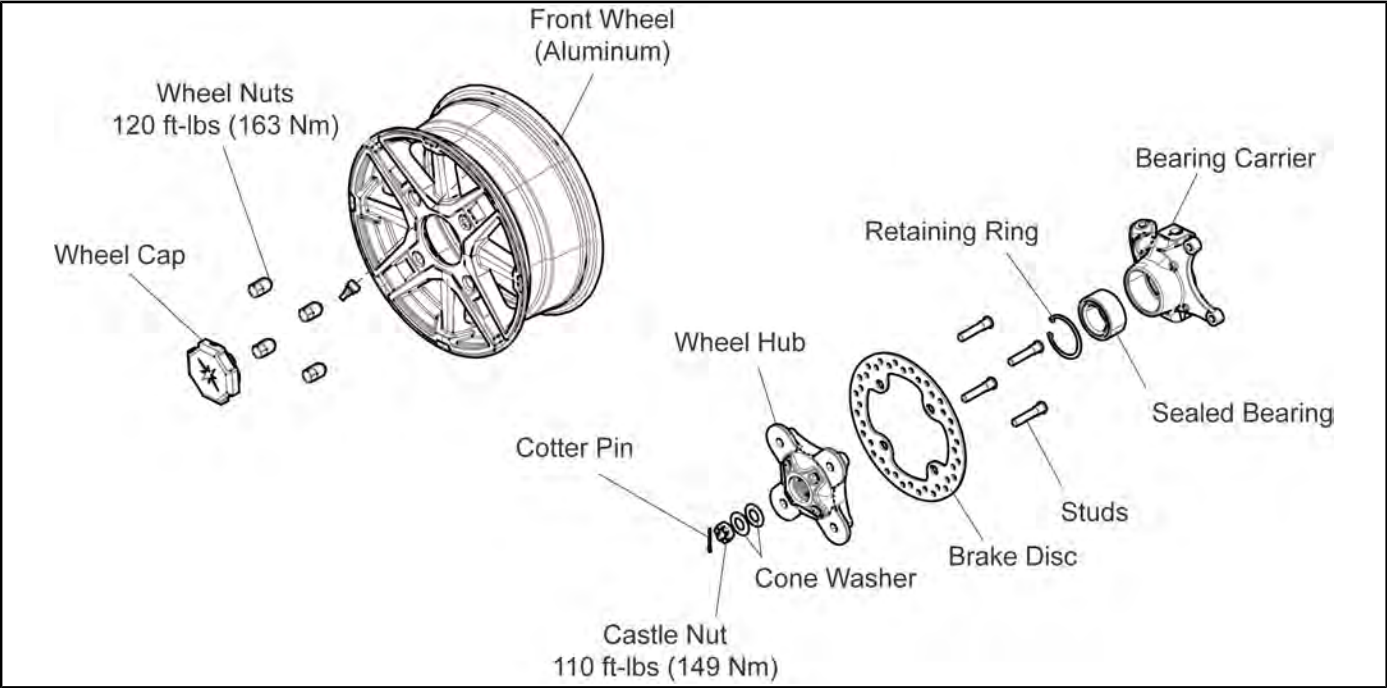

**Rear Hub Assembly View**

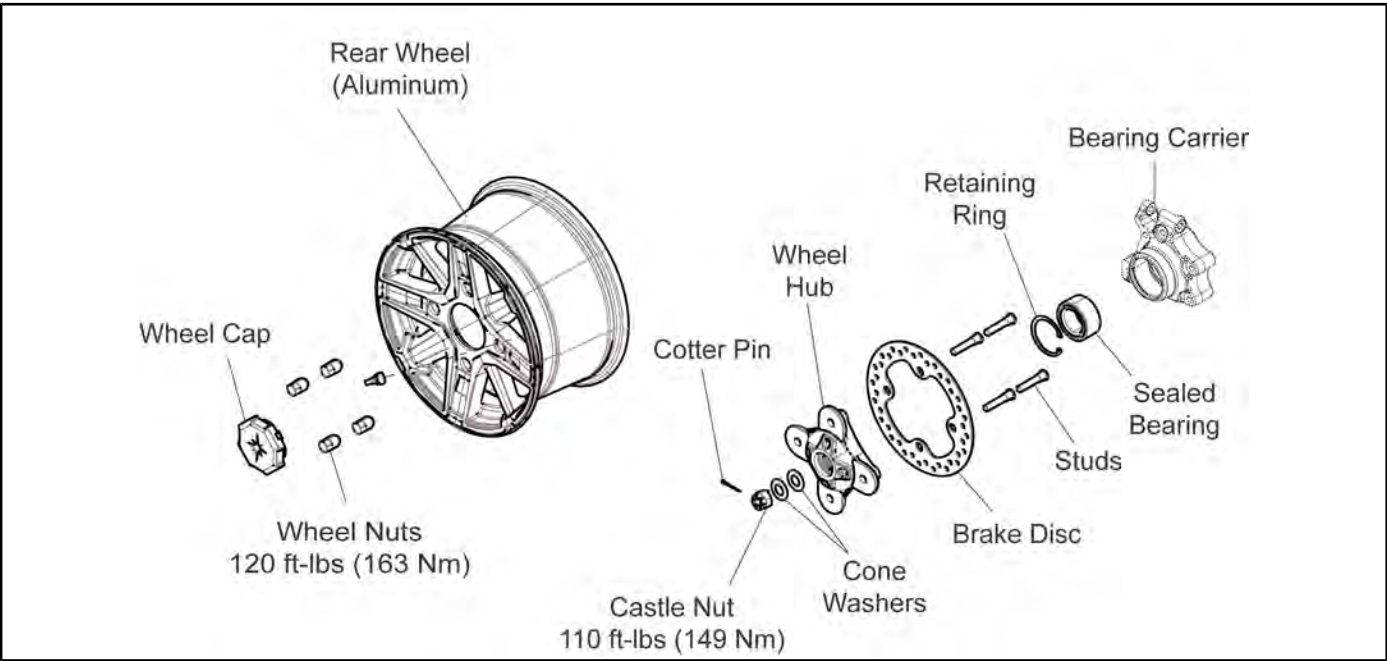

7





# CHAPTER 8 TRANSMISSION

SPECIFICATIONS .....	8.2
SPECIAL TOOLS .....	8.2
TORQUE SPECIFICATIONS .....	8.2
LUBRICATION .....	8.2
TRANSMISSION MOUNTING AND TORQUE VALUES .....	8.3
SHIFT LEVER .....	8.3
REMOVAL .....	8.3
INSTALLATION .....	8.4
SHIFT CABLE .....	8.4
INSPECTION .....	8.4
ADJUSTMENT .....	8.4
TRANSMISSION REMOVAL .....	8.5
TRANSMISSION INSTALLATION .....	8.8
TRANSMISSION SERVICE .....	8.12
TRANSMISSION DISASSEMBLY .....	8.12
GEAR / SHAFT / BEARING INSPECTION .....	8.17
SNORKEL GEAR BACKLASH PROCEDURE .....	8.18
TRANSMISSION SERVICE (INT'L) .....	8.25
DIFFERENTIAL OPERATION .....	8.25
TRANSMISSION DISASSEMBLY .....	8.26
PLANETARY DIFFERENTIAL DISASSEMBLY .....	8.31
PLANETARY DIFFERENTIAL BUSHING REPLACEMENT .....	8.32
PLANETARY DIFFERENTIAL ASSEMBLY .....	8.35
GEAR / SHAFT / BEARING INSPECTION .....	8.36
SNORKEL GEAR BACKLASH PROCEDURE .....	8.37
TROUBLESHOOTING .....	8.45
TROUBLESHOOTING CHECKLIST .....	8.45
TRANSMISSION ASSEMBLY VIEW .....	8.46
TRANSMISSION ASSEMBLY VIEW (INT'L) .....	8.48

# TRANSMISSION

## SPECIFICATIONS

### Special Tools

PART NUMBER	TOOL DESCRIPTION
PA-50231	Snorkel Tool
2871698 (Part of 2871702 Kit)	Rear Output Seal Driver
2871699 (Part of 2871702 Kit)	Rear Driveshaft Seal Guide
2871282	Bearing Seal Driver (50 mm)
PU-50566	Transmission Nut Socket
PU-50658	Clutch Center Distance Tool

**Bosch Automotive Service Solutions:** 1-800-345-2233  
or <http://polaris.service-solutions.com/>

### Torque Specifications

ITEM	TORQUE VALUE
Bell Crank Nut	<b>18 ft-lb (24 Nm)</b>
Fill / Drain Plugs	<b>14 ft-lbs (19 Nm)</b>
Gear Sector Cover	<b>12 ft-lb (16 Nm)</b>
Park Brake Disc Mounting Bolt (INT'L)	<b>14 ft-lb (20 Nm)</b>
Park Flange Screws	<b>10 ft-lb (14 Nm)</b>
Rear Transmission Isolator Bolt	<b>40 ft-lb (54 Nm)</b>

ITEM	TORQUE VALUE
Rear Transmission Mount Bracket Fasteners	<b>17 ft-lb (23 Nm)</b>
Snorkel Tube	Refer to Snorkel Gear Backlash Procedure, page 8.18
Snorkel Tube Locking Screw	<b>10 ft-lb (14 Nm)</b>
Shift Cable Bracket Bolts	<b>17 ft-lb (23 Nm)</b>
Shift Fork Screws	<b>10 ft-lb (14 Nm)</b>
Transmission Case Screws	<b>20 ft-lbs (27 Nm)</b>
Speed Sensor Screw	<b>12 ft-lb (16 Nm)</b>
Differential Cover Screw	<b>22 ft-lb (30 Nm)</b>

### Lubrication

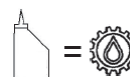

**Recommended Transmission Lubricant:**  
AGL (PN 2878068) (Quart)

**Capacity (Standard):** 44 oz. (1300 ml)  
**Capacity (INT'L):** 41 oz. (1200 ml)

## Transmission Mounting and Torque Values

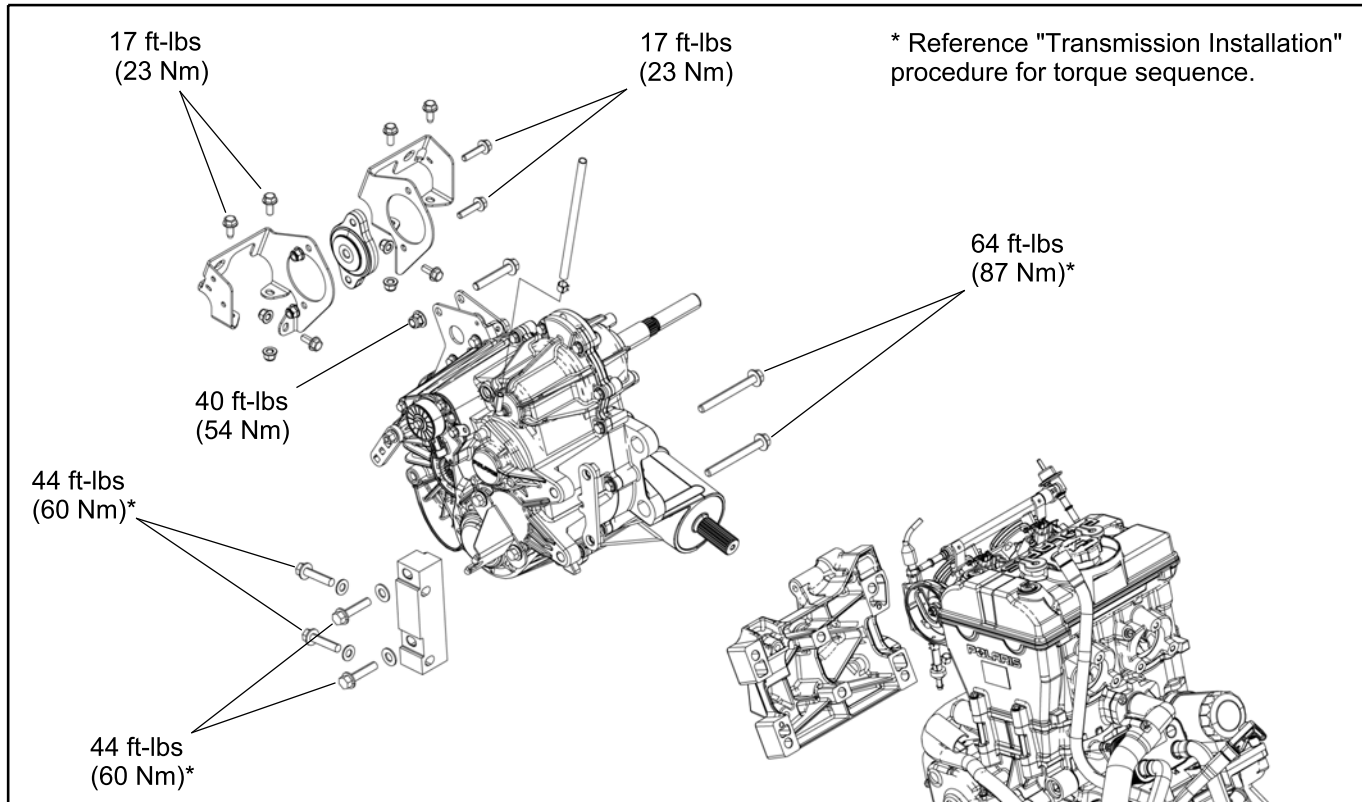

## SHIFT LEVER

### Removal

1. Remove the shift knob cover (Item 1), retaining screw (Item 2) and shift knob (Item 3) from the shift lever (Item 4).



2. Remove the screws retaining the center console using a T27 and T30 Torx driver. Remove the console from the vehicle.

3. Remove the clip and washer retaining the shift cable to the shift lever and disconnect the cable end from the lever.

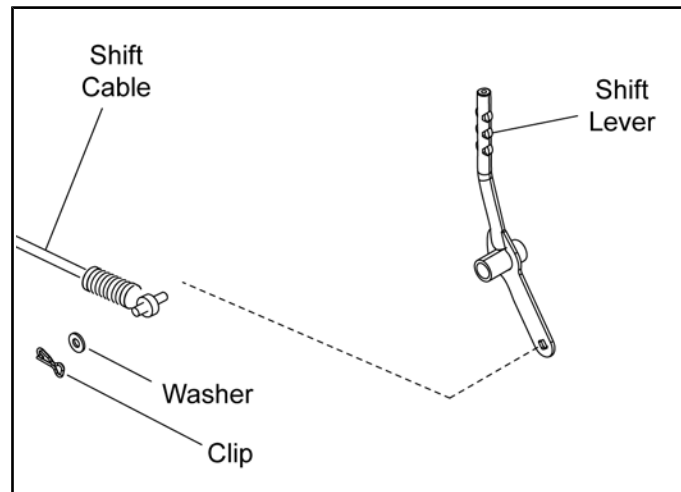

## TRANSMISSION

4. Remove the retaining ring (Item 1) and slide the shift lever (Item 3) off the mounting bracket and out from the frame.

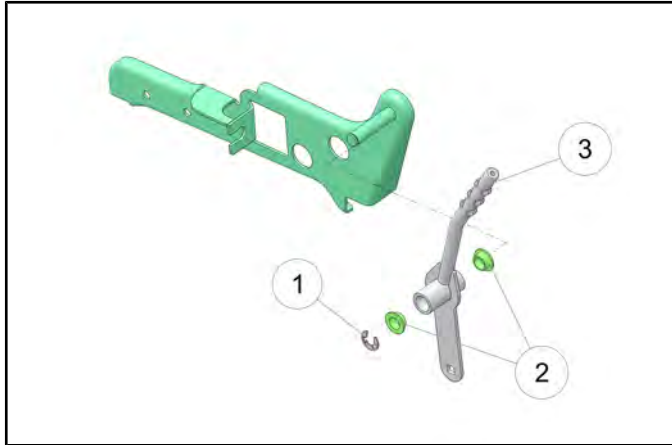

5. Remove both bushings (Item 2) from the shift lever and service as needed.

### Installation

1. Perform the removal steps in reverse order to install the gear shift lever (lever, cable, console, shift knob).

## SHIFT CABLE

### Inspection

Shift cable adjustment may be necessary if symptoms include:

- No gear position or AWD display on instrument cluster
- Ratcheting noise on deceleration
- Inability to engage into a gear
- Excessive gear lash (noise)
- Gear selector moving out of desired range

Inspect shift cable, clevis pins, and pivot bushings and replace if worn or damaged.

### Adjustment

1. Locate the shift cable attached to the transmission case in the right rear wheel well area.
2. Inspect shift cable (Item 1), clevis pin, pivot bushings, and dust boot (Item 2). Replace if worn or damaged.

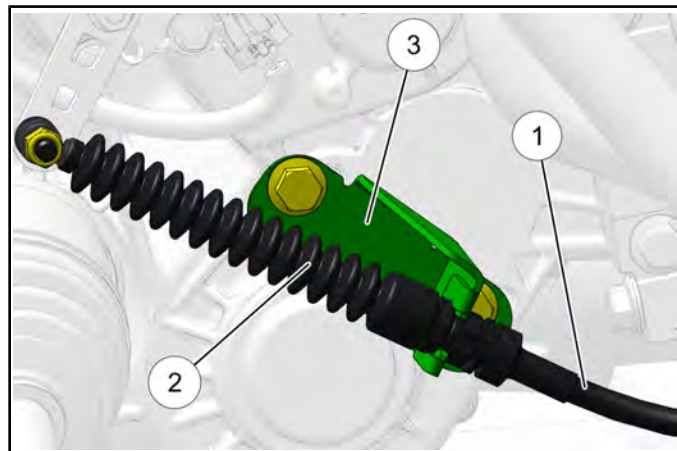

3. If adjustment is required, loosen the lower jam nut (Item 4) and pull the cable out of the mount (Item 3) to move the upper jam nut (Item 5).

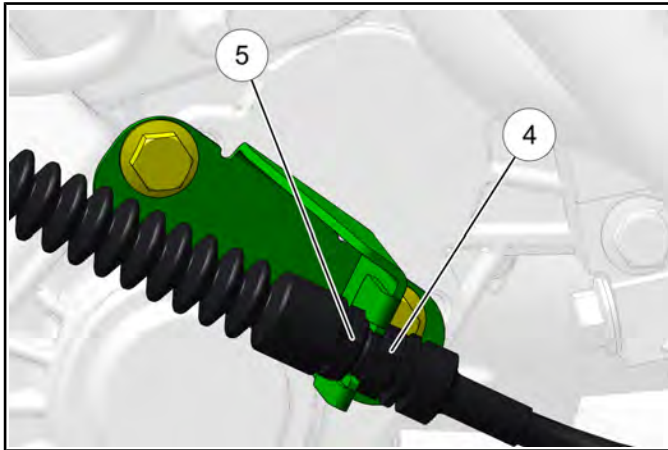

4. Adjust the shift cable so there is the same amount of cable travel when shifting slightly past HIGH gear and PARK.
5. Thread the upper or lower jam nut as required to obtain proper cable adjustment.

**NOTE: This procedure may require a few attempts to obtain the proper adjustment.**

6. Once the proper adjustment is obtained, place the shift cable and upper jam nut into the mount. Tighten the lower jam nut against the mount.
7. Start engine and shift through all gears to ensure the shift cable is properly adjusted. If transmission still ratchets after cable adjustment, the transmission will require service.

## TRANSMISSION REMOVAL

### CAUTION

Serious injury may result if machine tips or falls. Be sure machine is secure before beginning this procedure. Always wear eye protection.

1. Remove the seats, console cover and engine service panel (see Chapter 5).
2. Disconnect the (-) negative battery cable from the battery.
3. Remove the rear bumper and cargo box as an assembly (see Chapter 5).
4. Remove the air box assembly (see Chapter 4 "ECT Sensor Replacement").
5. Raise and support the vehicle.
6. Remove the prop shaft from the transmission output shaft (see Chapter 7).

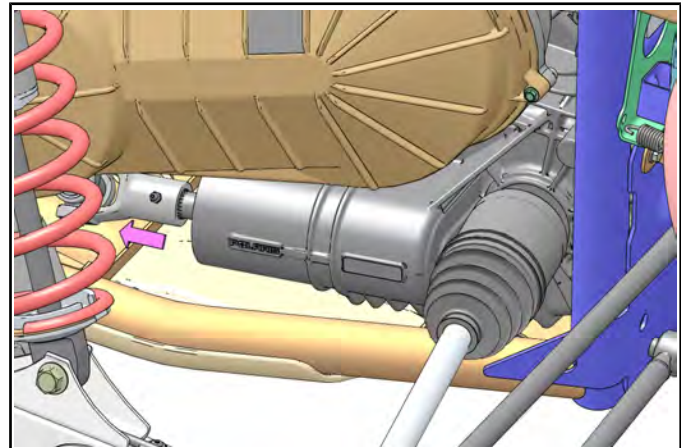

7. Remove rear wheels from the vehicle.
8. If internal transmission repair is required, drain the transmission lubricant (see Chapter 2).
9. Remove the lower mounting bolt from the left rear shock. Swing shock outward.
10. Remove the outer clutch cover, drive belt, drive clutch, driven clutch, inner clutch cover and clutch outlet duct (see Chapter 6).

**NOTE: Be sure to use the correct Drive Clutch Puller (PN 2872085) to prevent damage to crankshaft.**

# TRANSMISSION

## CAUTION

### Correct Drive Clutch Puller P/N 2872085

2872085 - Correct Drive Clutch Puller For RZR XP 900

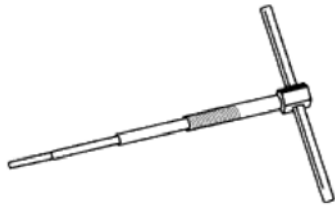

PA-48595 - Incorrect Drive Clutch Puller

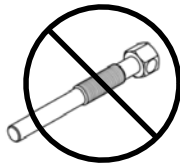

11. Loosely install the left rear shock bolt to hold left rear trailing arm up in position.
12. Remove the stabilizer bar mounting bolt and nut (Item 1) from both sides. Discard nuts and replace with new upon assembly.

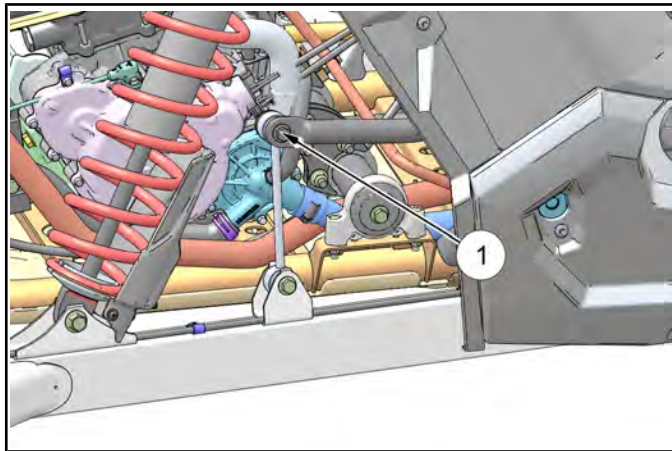

13. Remove the four bolts (Item 2) attaching the upper and lower radius rods to the bearing carriers (left and right side). Discard nuts and replace with new upon assembly. Allow the radius rods swing downward.

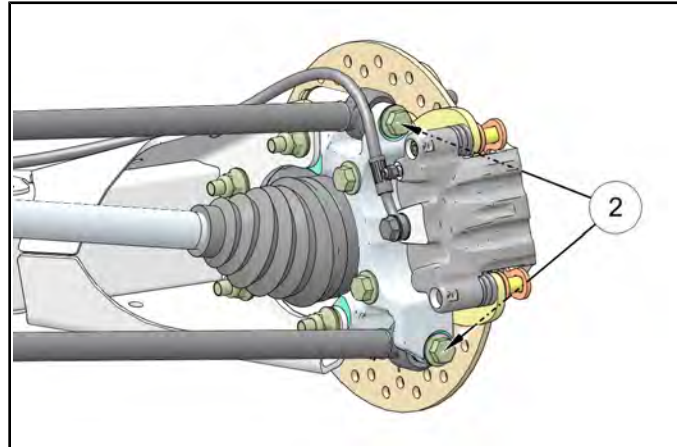

14. Remove both lower shock bolts (left and right side) while supporting the trailing arms from underneath. Lift trailing arms up and swing trailing arms outward to remove the drive shafts from the transmission.
15. Maneuver the drive shafts out of the vehicle frame. Reinstall the lower shock bolts (Item 3) to hold the trailing arms up during the rest of the removal procedure.

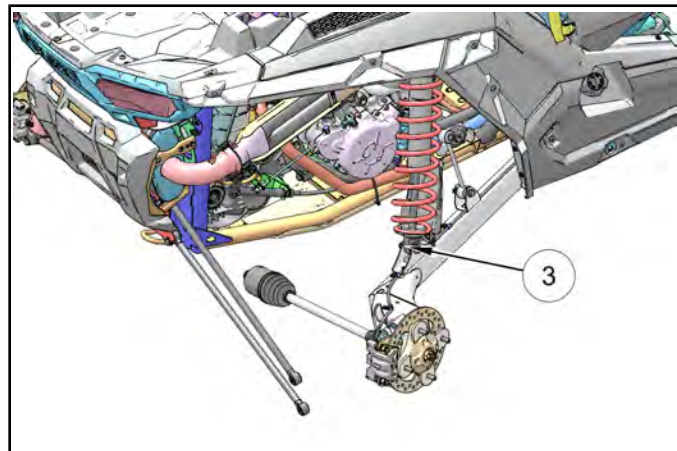

## TRANSMISSION

16. Place a spacer or support between the vehicle frame and engine to hold the engine up in position.

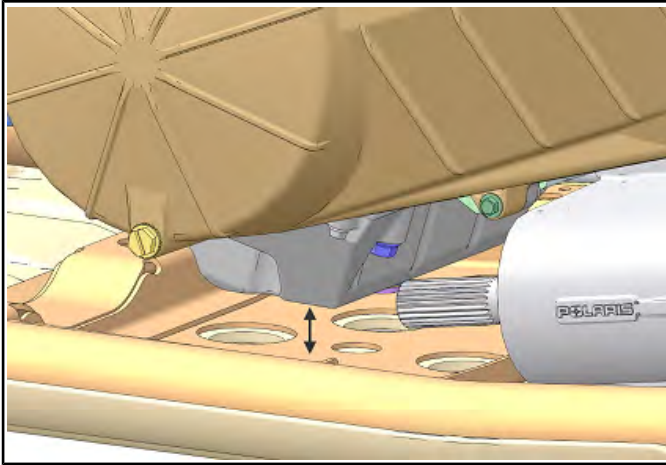

19. Remove the wire ties retaining harness to transmission and mounts.

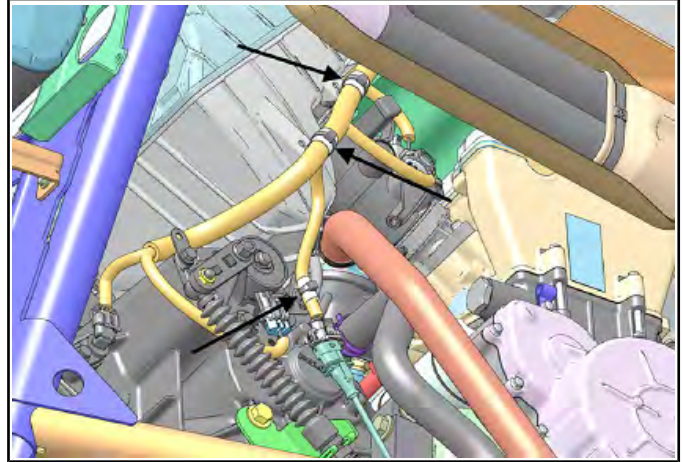

17. Remove vent hose from transmission.  
18. Remove the gear position switch connector (Item 6), speed sensor connector (Item 5), crankshaft position sensor connector (Item 4), shift bracket bolts and shift bracket (Item 7), shift cable clevis pin and washer (Item 8) from the transmission.

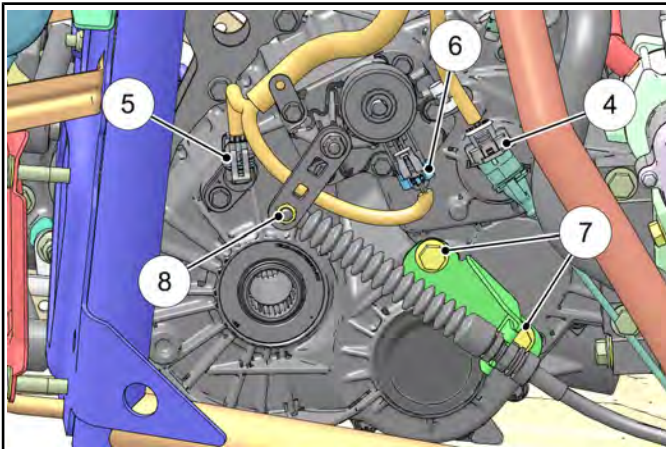

20. Using a 15mm socket, remove the four bolts from the left side (Item 9) and right side (Item 10), securing the transmission to the engine.

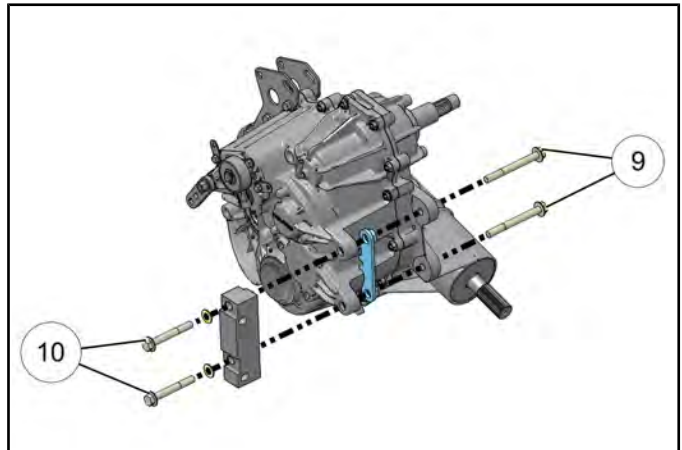

21. Remove the two rear exhaust springs securing the muffler to the rear transmission mounting bracket.

8



## TRANSMISSION

22. Remove the two fasteners (Item 11) attaching the rear transmission mount bracket assembly to the frame. Remove the fasteners (Item 12) that attach the rear mount to the transmission. Remove the mount assembly from the vehicle.

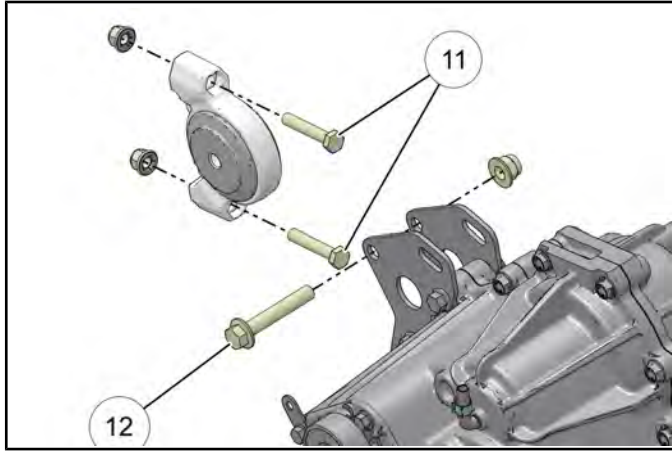

23. Slide transmission towards the rear of the vehicle. Lift and rotate the top of the transmission towards the left side of the vehicle. With the help of an assistant, remove transmission from the left rear wheel well area.

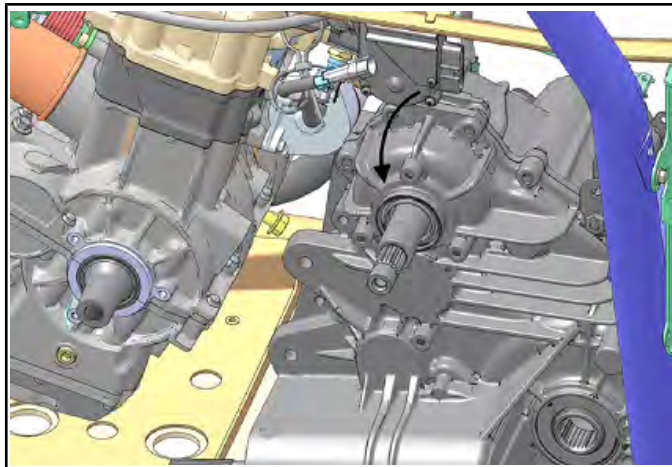

## TRANSMISSION INSTALLATION

1. With the help of an assistant, position the transmission into the vehicle frame through the left rear wheel well area.
2. Slide transmission towards rear of the vehicle and rotate the top of the transmission toward the right side of the vehicle.

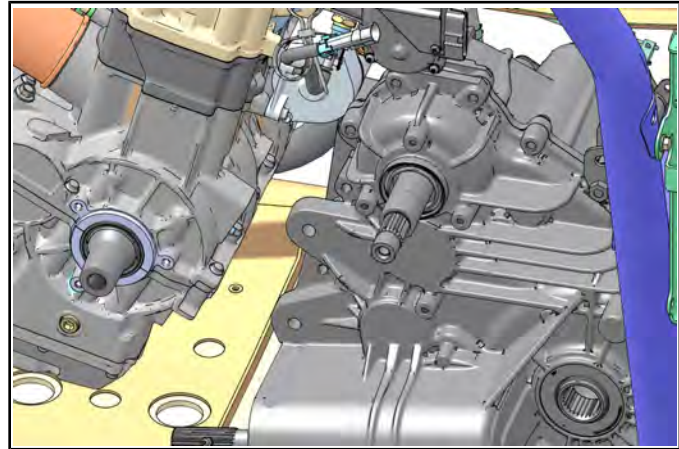

3. Install the rear transmission mount to the frame and secure with M8 bolts and nuts. Torque nuts to specification.

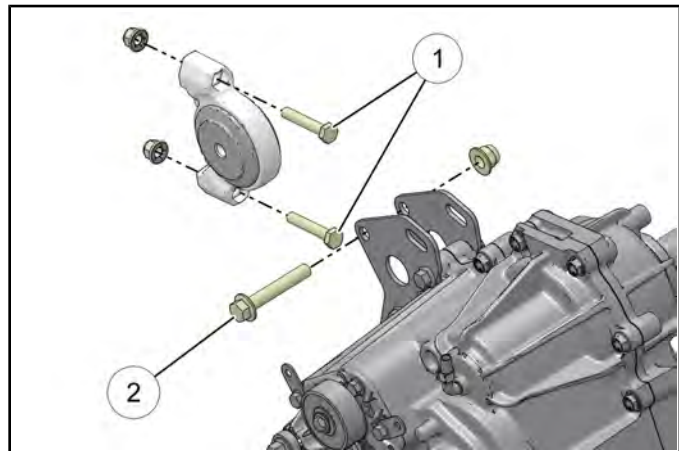

Rear Transmission Mount Bracket Fasteners (Item 1):  
**17 ft-lb (23 Nm)**

# TRANSMISSION

4. Install M10 bolt and nut securing the transmission bracket to the rear mount. Torque fasteners to specification.

 = T
Rear Transmission Isolator Fasteners (Item 2): <b>40 ft-lb (54 Nm)</b>

5. Install the two rear exhaust springs securing the muffler to the rear transmission mounting bracket.
6. Install the Clutch Center Distance Tool (PU-50658) onto the crankshaft and transmission input shaft to properly position the clutch center distance.

**IMPORTANT:** Tool should bottom out on the transmission input shaft and lay flush on the crankshaft.

7. Loosen the two bolts retaining the transmission coupler bracket to the engine on the right side.

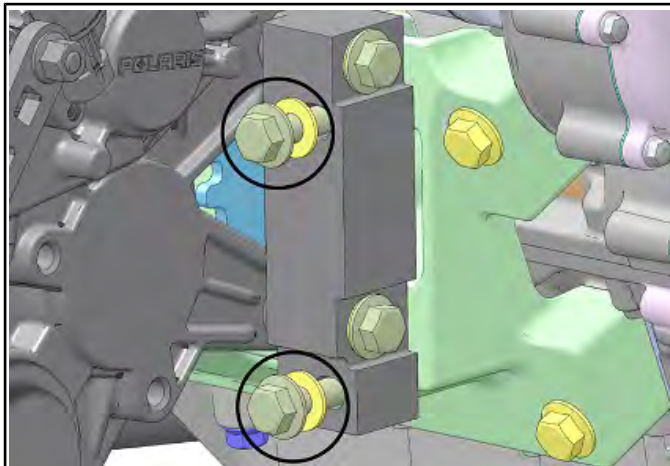

8. Align front transmission mounting holes with transmission joint bracket mounting holes on engine.
9. Loosely install the two longer bolts into left side mounting holes and two shorter bolts with washers into right side mounting holes.

**NOTE:** DO NOT torque fasteners at this time.

10. Torque left side mounting bolts to specification in sequence.

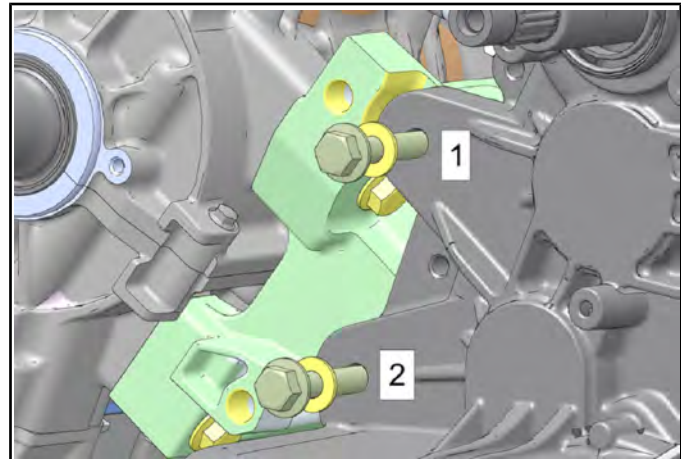

11. Torque right side mounting bolts to specification using the numbered sequence shown.

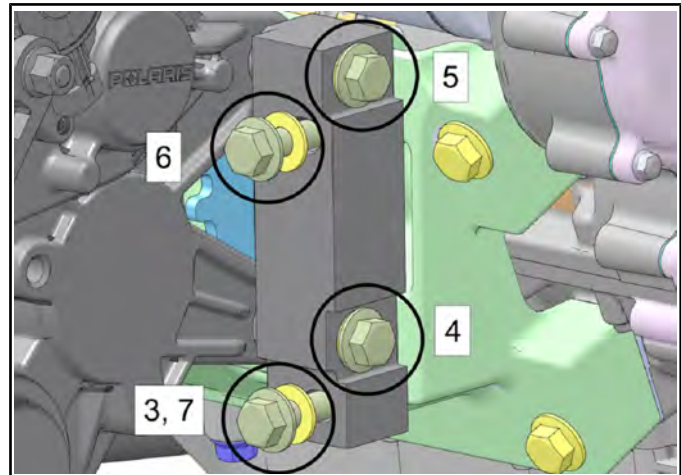

 = T
Engine / Transmission Mounting Bolts:  <b>Step 1-2: 64 ft-lb (87 Nm)</b> <b>Step 3: 5 ft-lb (7 Nm)</b> <b>Step 4-7: 44 ft-lb (60 Nm)</b>

12. Remove the clutch center distance tool.

# TRANSMISSION

13. Remove the spacer or support between the vehicle frame and engine.

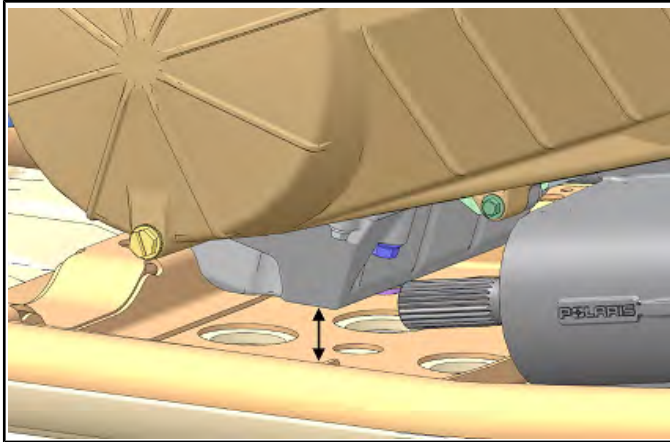

14. Install and properly route the gear position switch connector (Item 5), speed sensor connector (Item 6), crankshaft position sensor connector (Item 7), shift bracket and shift bracket bolts (Item 8), shift cable clevis pin and washer (Item 9) onto the transmission.

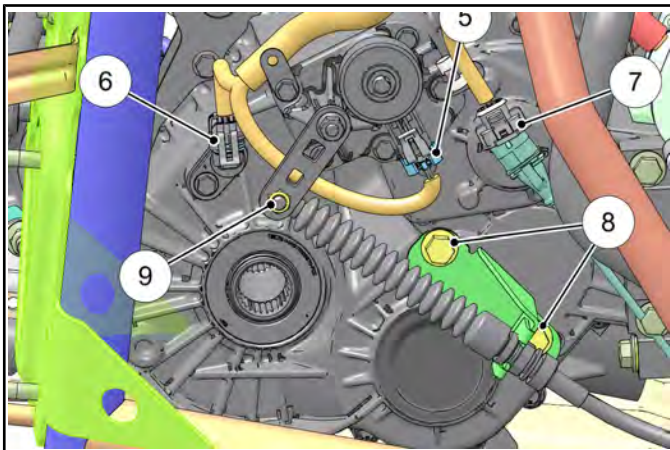

15. Torque the two shift cable bracket bolts to specification.

 = T
Shift Cable Bracket Bolts: <b>17 ft-lb (23 Nm)</b>

16. Install three wire ties to retain wire harness to transmission and mounts.

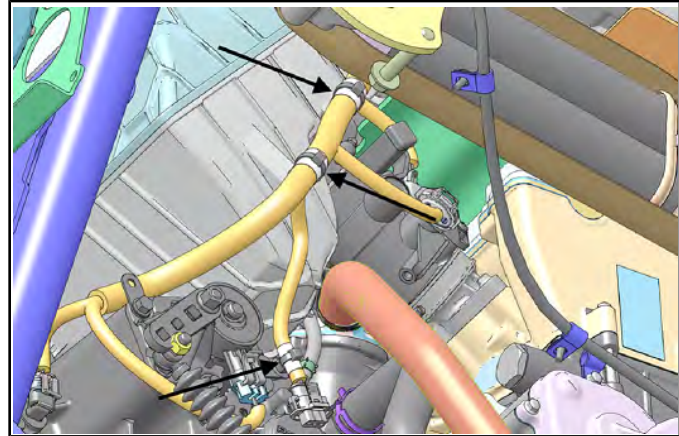

17. Install and properly route the vent hose.
18. Lubricate the transmission splines and mid propshaft joint splines with Polaris All Purpose Grease. Install the propshaft onto the transmission output shaft (see Chapter 7).
19. Install inner clutch cover, outlet duct, drive clutch, driven clutch, belt and outer clutch cover (see Chapter 6).
20. Install new spring ring (Item 10) on rear drive shafts. Apply an anti-seize compound to the splines (Item 11).

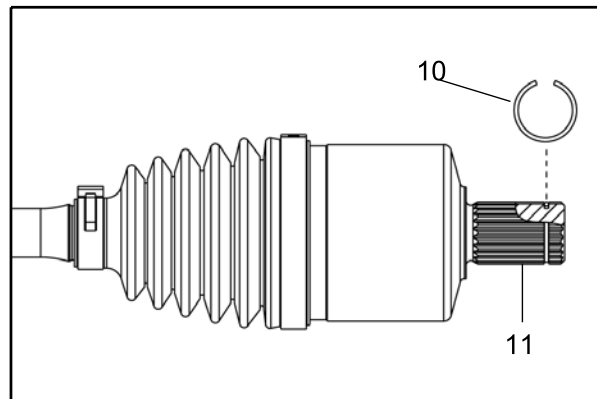

21. Remove lower shock mounting bolt and swing the rear trailing arm out and up. Align the splines of the drive shaft with the transmission splines. Push inward on the trailing arm assembly until the rear drive shafts lock into the transmission splines.
22. Install the rear shocks onto the trailing arms and install the lower mounting bolts with new retaining nuts. Torque to specification.

# TRANSMISSION

23. Install the four rear radius rods to the bearing carriers on each side. Use new retaining fasteners (Item 12). Torque to specification.

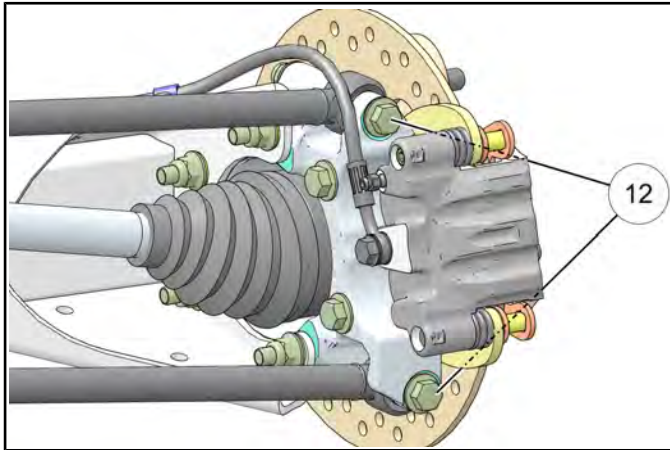

24. Install the stabilizer bar link mounting bolts and new nuts (Item 13). Torque to specification.

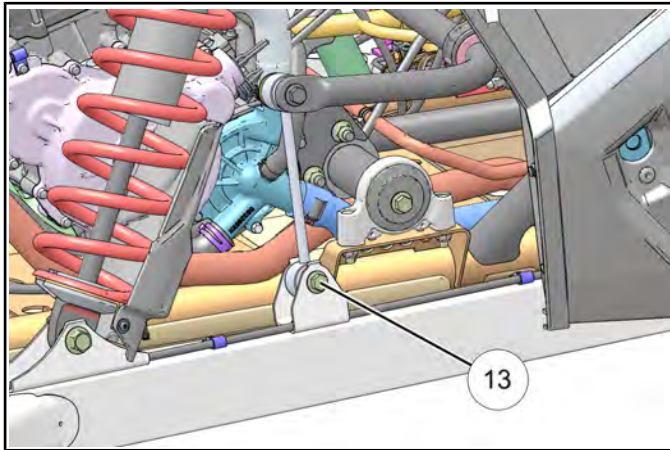

25. Install rear wheels and wheel nuts. Torque to specification.

 = T
Rear Shock Lower Bolt: <b>70 ft-lbs (95 Nm)</b>
Outer Radius Rod Bolts: <b>40 ft-lb (54 Nm)</b>
Stabilizer Bar Linkage: <b>40 ft-lbs (54 Nm)</b>
Wheel Nuts: <b>120 ft-lbs (163 Nm)</b>

26. Properly lower the vehicle.

27. Install the air box assembly as outlined in the EFI Chapter (see Chapter 4 “ECT Sensor Replacement”).
28. Install the rear bumper and cargo box as an assembly (see Chapter 5).
29. Connect the (-) negative battery cable.
30. Install the engine service panel, console cover and seats.
31. If transmission lubricant was drained, fill the transmission with the specified amount of **Polaris AGL** (see Chapter 2 “Transmission Lubrication”).

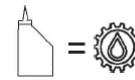

Recommended Transmission Lubricant:  
**AGL (PN 2878068) (Quart)**

Capacity (Standard): **44 oz. (1300 ml)**  
 Capacity (INT'L): **41 oz. (1200 ml)**

# TRANSMISSION

## TRANSMISSION SERVICE

### Transmission Disassembly

**NOTE:** Refer to the exploded view at the end of this chapter as a reference.

1. Place transmission in High gear before disassembly.
2. Drain and properly dispose of the transmission lubricant (see Chapter 2).
3. Remove the bellcrank nut (Item 1) and bellcrank (Item 2).

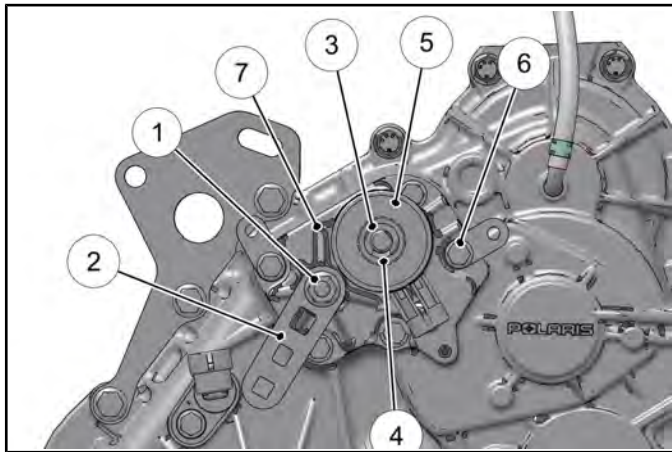

4. Remove E-clip (Item 3) that retains spring washer (Item 4), flat washer (Item 4) and gear switch (Item 5). Remove the switch.
5. Remove the sector cover bolts (Item 6) and remove the sector cover (Item 7).

**NOTE:** Removal can be aided by using your thumbs to press in on the shafts while pulling out the cover with your fingers.

6. Remove the compression spring (H).

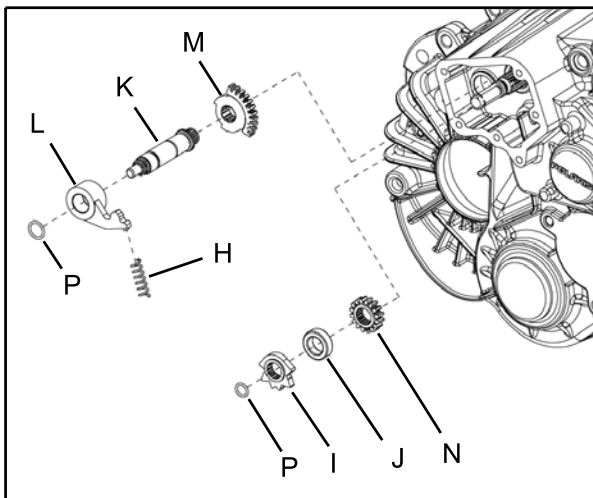

7. Remove the detent star (I). Note how the detent star fits onto the splined shaft with the raised edge facing outward for reassembly.
8. Remove the spacer (J).
9. Remove the shift shaft (K), detent pawl (L) and the shift sector gears (M and N).

**NOTE:** Note the timing marks on the shift gears (M and N) for reassembly purposes.

10. Remove the O-rings (P) from each shaft and discard. Use new O-rings upon assembly.
11. Remove all the transmission case bolts. Using suitable pry bars, remove the cover using the designated pry points (indicated by the black arrows in the illustration below).

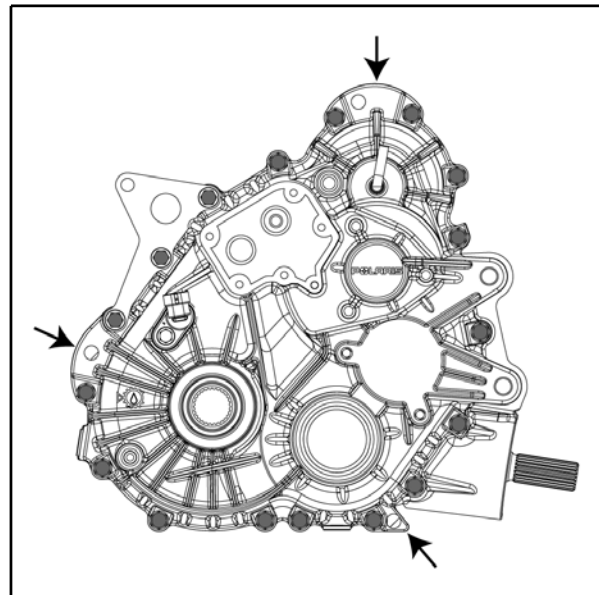

### CAUTION

**Do not pry on case sealing surfaces.  
Use only the designated pry points  
on the transmission.**

## TRANSMISSION

12. Lift up on the shift shaft rail (Q) and move the rail assembly rearward to allow the shift fork pins to be removed from the shift drum (R). Remove the shift drum (R) from the transmission housing.

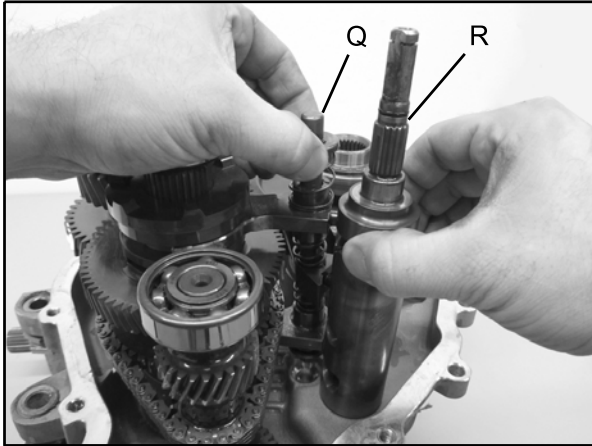

13. Remove the shift shaft rail (Q) and shift forks from the transmission housing as an assembly.

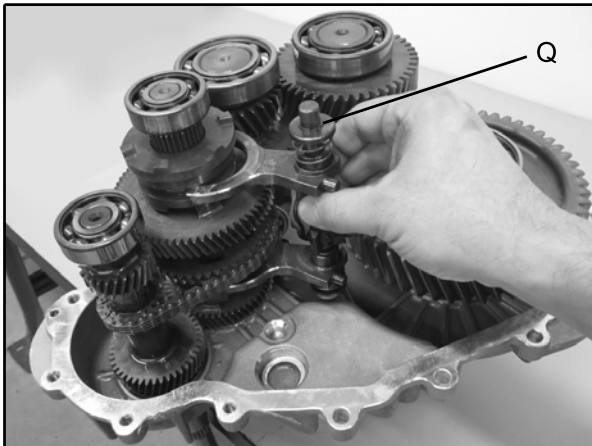

14. Remove the rear output shaft assembly (S) by lifting underneath the gear or by tapping the shaft from the opposite side.

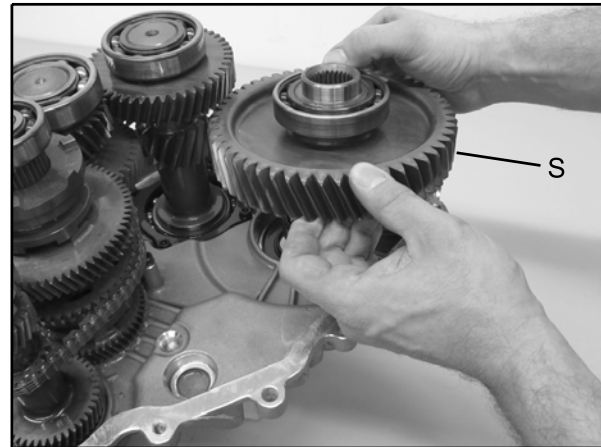

15. Remove the idler gear shaft assembly (T) and gear cluster assembly (U) from the transmission housing by pulling both assemblies straight up.

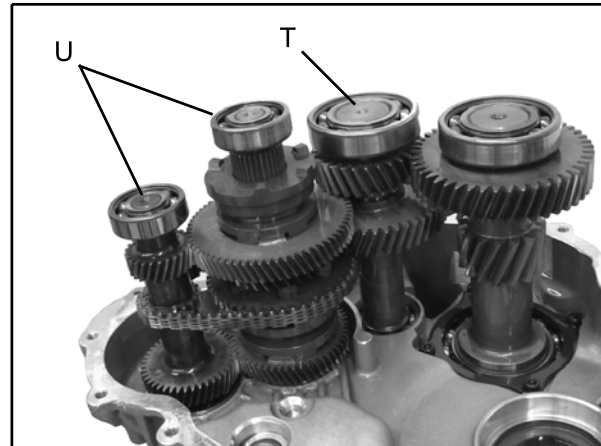

16. Place the gear cluster assembly on a clean surface for inspection. If disassembly is required, refer to "Gear Cluster Disassembly".

# TRANSMISSION

- Using a 5 mm Allen wrench, remove the screws that secure the pinion shaft assembly (V). Lift the pinion shaft assembly straight up to remove it from the housing. Note the longer screw (W) that locks the snorkel tube.

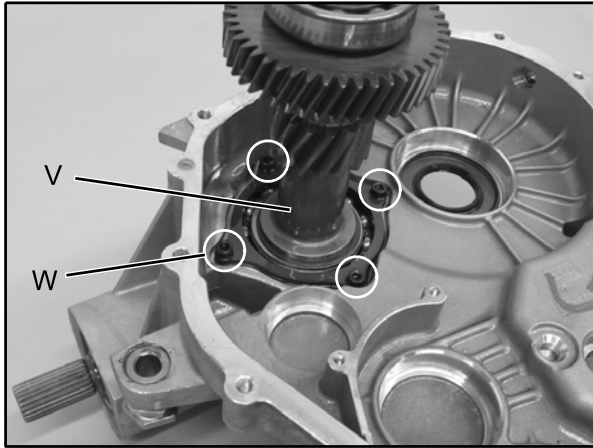

- Remove all seals from the gearcase halves and clean the cases in preparation for assembly.

### Gear Cluster Disassembly

- Remove the bearing from the reverse shaft using a bearing puller. Remove the retaining ring and slide the washers, 53T gear and needle bearing off the reverse shaft (see Figure 8-1).

Figure 8-1

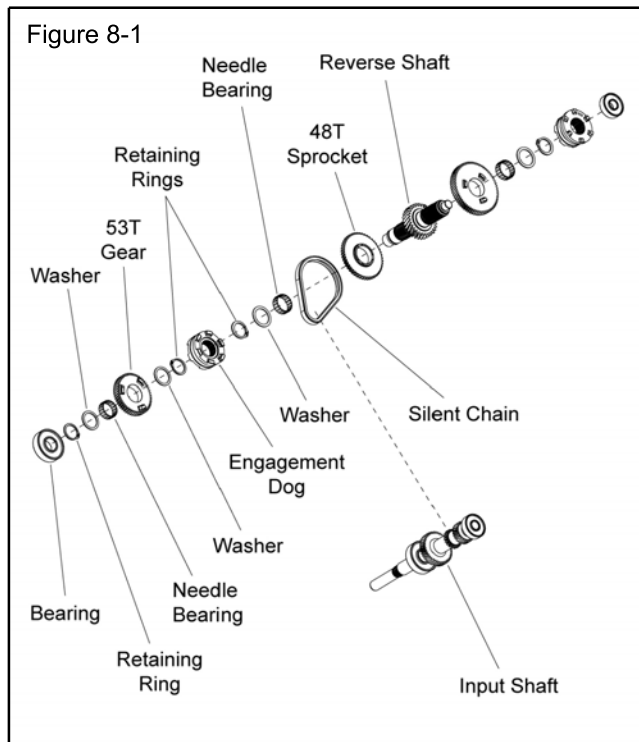

- Remove the retaining ring and engagement dog from the reverse shaft (see Figure 8-1).
- Remove the retaining ring, washer, needle bearing, and sprocket from the reverse shaft (see Figure 8-1).
- Tilt the two shafts towards each other and remove the silent chain from the two shafts.
- If necessary, disassemble the other end of the reverse shaft. Remove the bearing, engagement dog, retaining ring, washer, gear and needle bearing from the reverse shaft (see Figure 8-2).

Figure 8-2

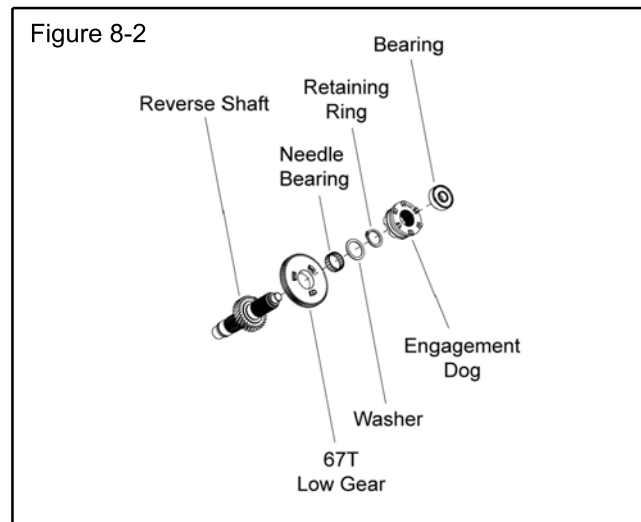

24. To disassemble the shift shaft rail remove the snap ring (X) from the end of the shift rail on either side.

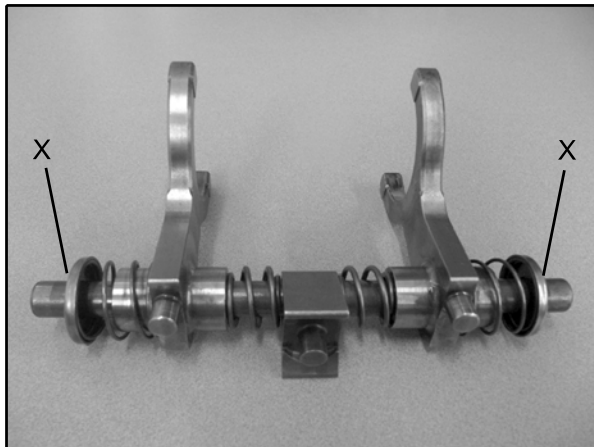

26. Using the Snorkel Tool (PA-50231), fully loosen the snorkel tube.

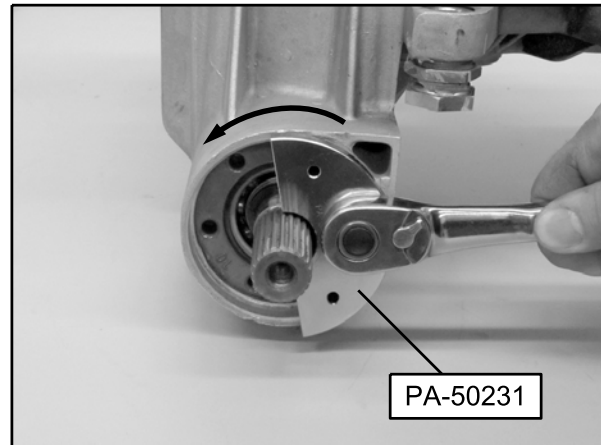

## CAUTION

Use caution when disassembling the shift rail. The compressed springs on the shift rail may pop off causing eye or face injury.

Snorkel Shaft Removal / Disassembly

## ⚠ CAUTION

The pinion shaft must be removed prior to removing the snorkel shaft assembly. Failure to remove pinion shaft, will result in damage to the snorkel shaft.

27. Remove the snorkel tube and shaft assembly from the transmission case.

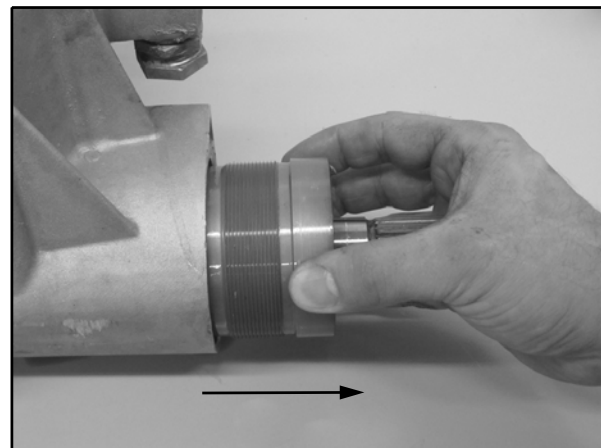

25. Extract the seal from the snorkel shaft to access the snorkel tube for removal.

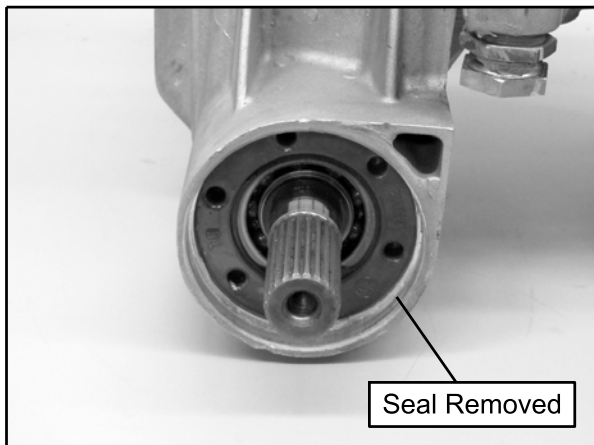

28. Remove the snap ring (Y) and shim (Z) from the snorkel shaft.

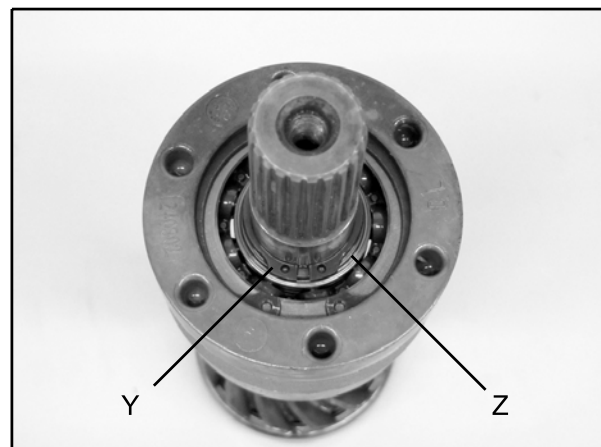



## TRANSMISSION

29. Use an arbor press to remove the snorkel tube from the snorkel shaft.

30. Remove the snap ring (A) and shim (B) retaining the bearing in the snorkel tube.

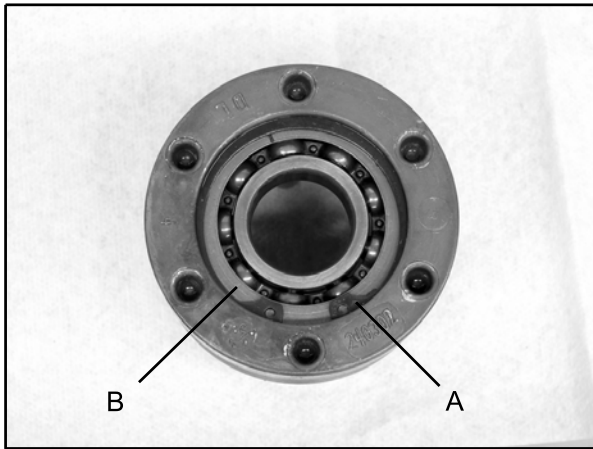

31. Lightly tap on the bearing from the opposite side to remove it from the snorkel tube.



32. Remove the retaining ring to remove the remaining washer, bearing and gear from the snorkel shaft.

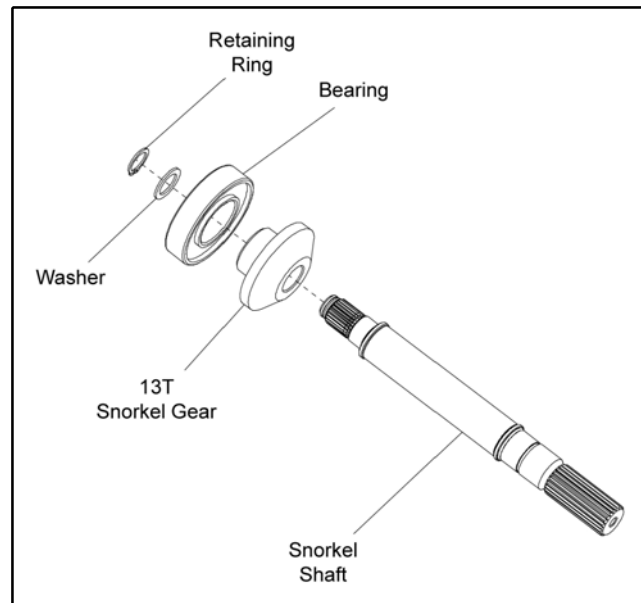

## Gear / Shaft / Bearing Inspection

Inspect all gear sets and shafts for excessive wear or damage.

**IMPORTANT:** If gear replacement is required, be sure to also replace the corresponding gear or gear shaft.

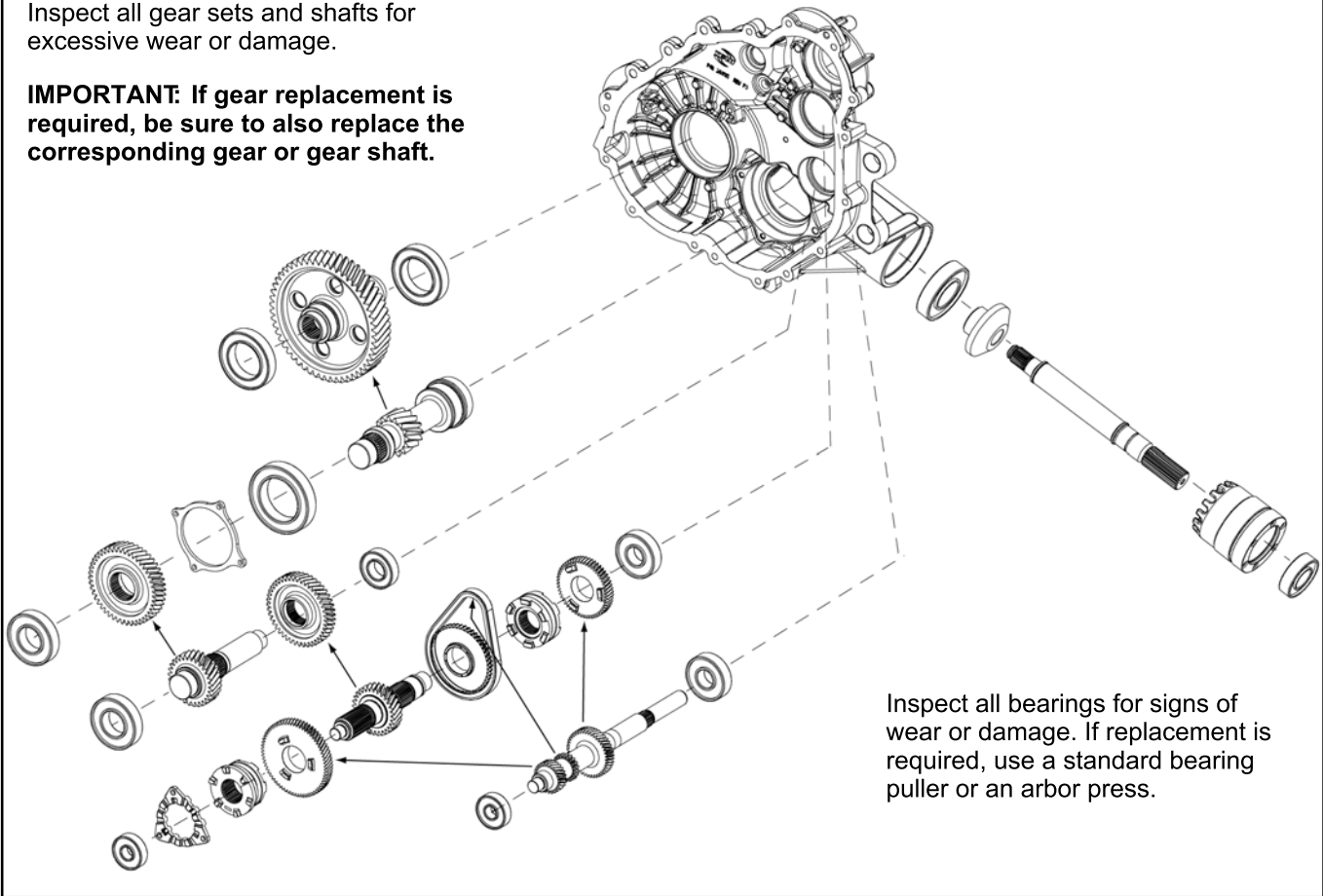

Inspect all bearings for signs of wear or damage. If replacement is required, use a standard bearing puller or an arbor press.

# TRANSMISSION

## Snorkel Gear Backlash Procedure

1. Reassemble the snorkel tube and snorkel shaft assembly by reversing the disassembly procedure (see "Snorkel Shaft Removal / Disassembly").

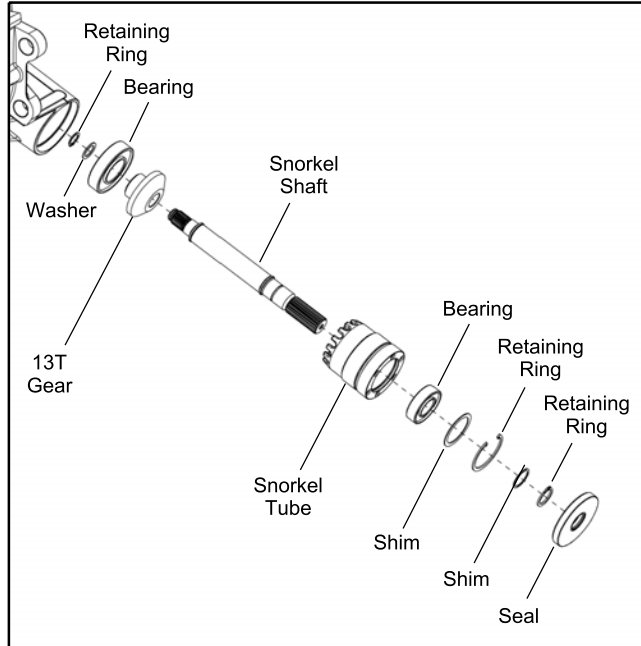

2. After the 13T gear and bearing are pressed onto the snorkel shaft (flush to the shoulder), install the washer and new retaining ring.
3. Press the gear back towards the retaining ring. Avoid excessive force so the retaining ring is not damaged or pre-stressed significantly.

**NOTE: Failure to press the gear back against the washer and retaining ring will lead to a gear backlash change after vehicle is placed into service.**

4. Apply a small amount of white lithium grease or Anti-Seize on the threads of the snorkel tube.

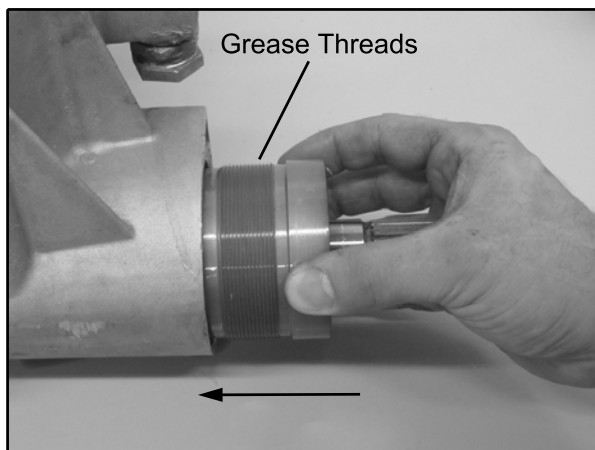

5. Install the snorkel shaft into the gearcase. Using the Snorkel Tool (PA-50231), tighten the snorkel tube until it is lightly seated in the transmission housing.

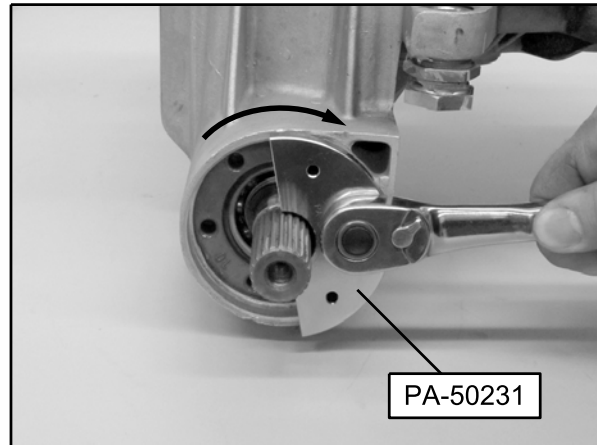

6. Inspect the pinion shaft assembly. Replace bearings if needed. Inspect each gear for damage, chips or abnormally worn teeth.

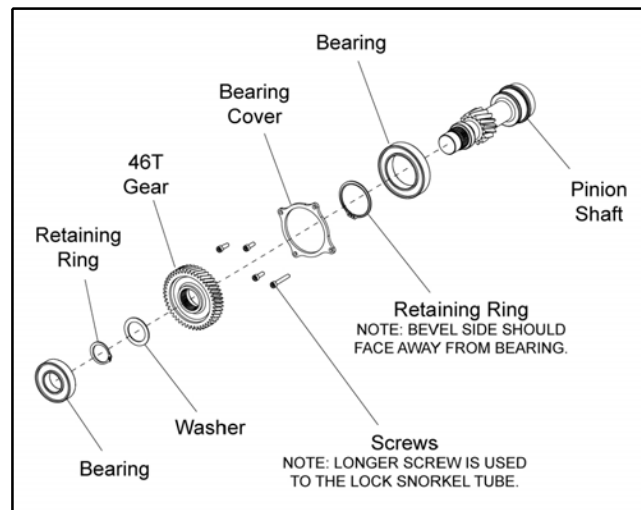

**NOTE: If pinion shaft was disassembled, the bearing cover must be installed on the shaft before installing the 46T gear.**

7. Install the pinion shaft assembly. Be sure to properly mesh the snorkel shaft bevel gear with the pinion shaft bevel gear.
8. Apply Loctite® 242™ to the threads of the bearing cover retaining screws.

9. Using a 5 mm Allen wrench, install only the (3) screws that secure the pinion shaft assembly as shown below. Leave the longer locking screw (A) out at this point.

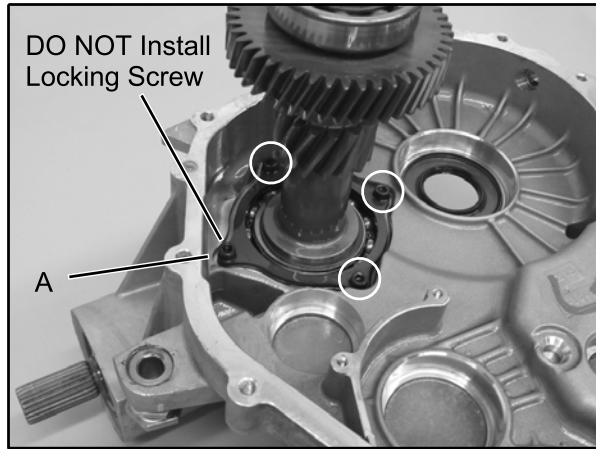

**NOTE: DO NOT install the longer screw (A). Installing the longer screw will lock the snorkel tube and not allow for backlash setting adjustment.**

10. Torque the bearing cover retaining screws to specification.

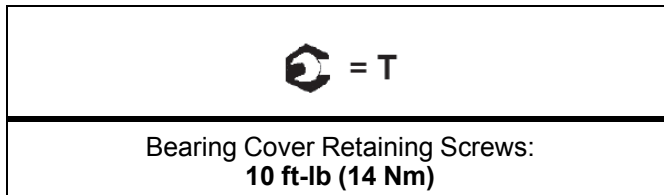

11. Rotate the snorkel tube *counterclockwise* using the snorkel tool (PA-50231) until the snorkel gear and pinion gear have 'zero' backlash.

**NOTE: DO NOT overtighten the snorkel tube when backing it out. At the 'zero' backlash position, you should still be able to turn the snorkel shaft using your fingers, but it will feel rough and may have some tight spots.**

12. Look down into the transmission housing to see the snorkel locking screw hole opening to reference your starting point.

**NOTE: If you have a hard time seeing into the hole, insert a small Allen wrench, punch or screwdriver into the hole to feel when the notch is aligned with the hole.**

13. Slowly rotate the snorkel tube *clockwise* while counting the number of notches passing through the hole opening as you rotate the tube. Rotate the snorkel tube to the **3rd** notch from the 'zero' backlash position obtained in step 11.

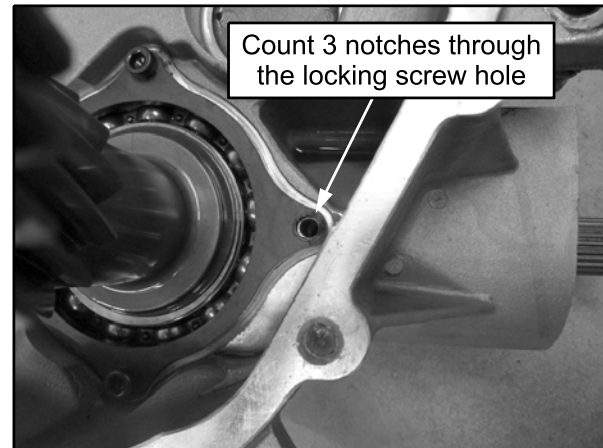

14. Check the pinion shaft gear backlash again by feel. If the pinion shaft gear lash appears to be too tight, rotate the snorkel shaft *clockwise* to the next notch (4th notch).

15. Once the backlash is set, apply Loctite® 242™ to the threads and install the locking screw to secure the snorkel tube.

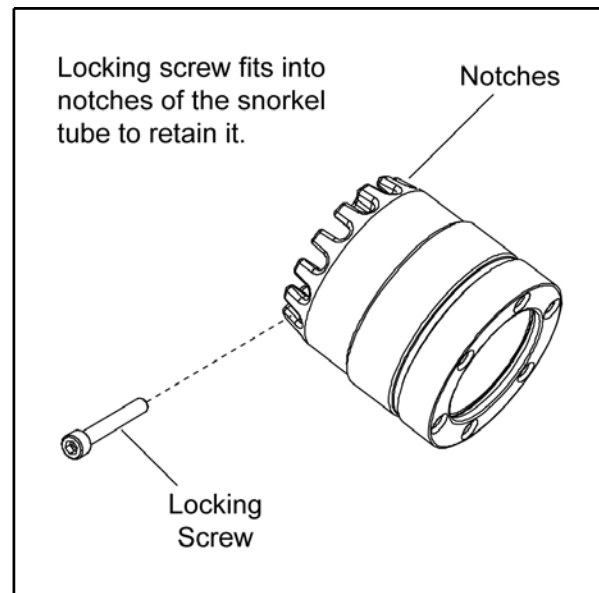

# TRANSMISSION

16. Torque the locking screw to specification.

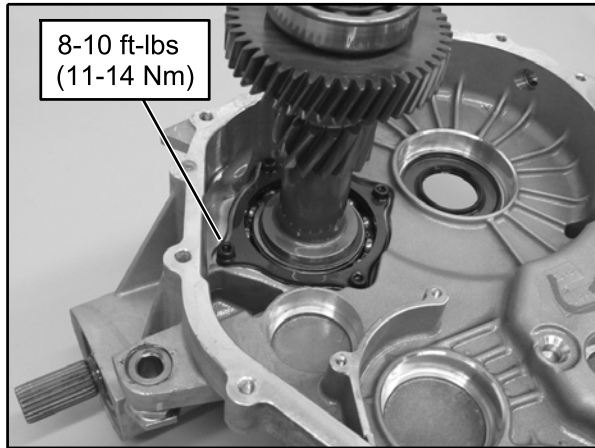

 = T  
**Snorkel Locking Screw:  
10 ft-lb (14 Nm)**

## Transmission Assembly

**NOTE: The snorkel shaft and pinion shaft must be installed prior to transmission assembly. The snorkel shaft cannot be installed after assembling the transmission.**

17. Clean both transmission case halves thoroughly. Inspect case half mating surfaces for damage.

18. Assemble the reverse shaft assembly and input shaft assembly if previously disassembled (see illustrations).

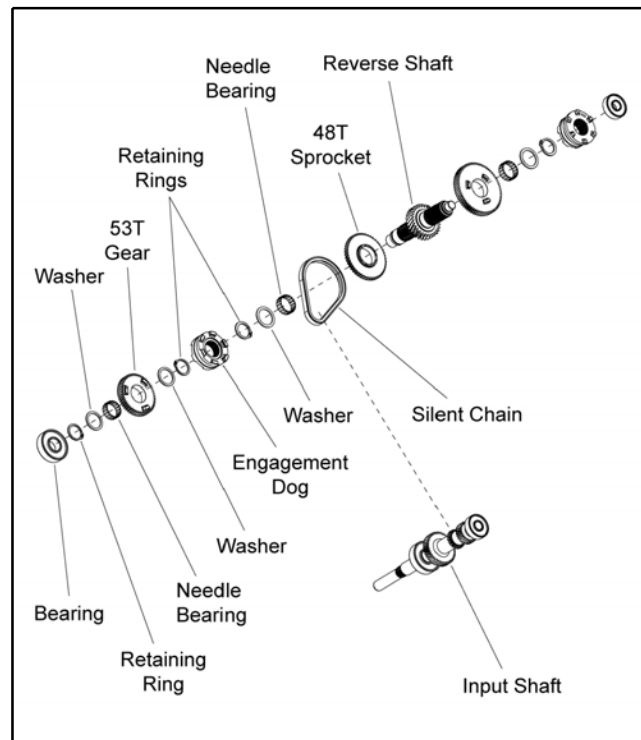
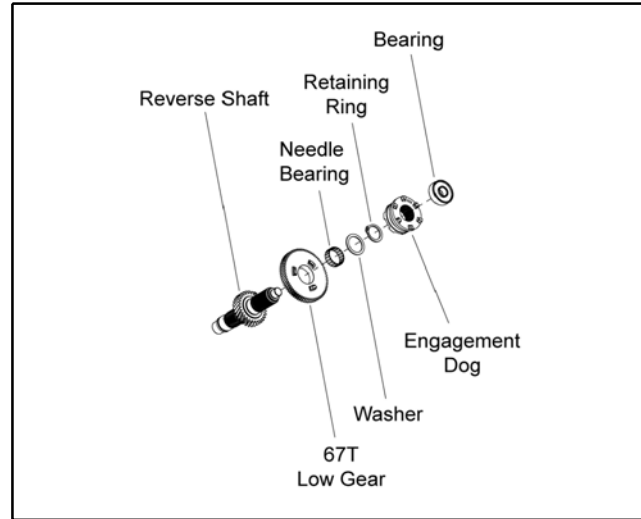

## TRANSMISSION

19. Install the idler gear shaft assembly (A) and gear cluster assembly (B) into the transmission housing, all at the same time.

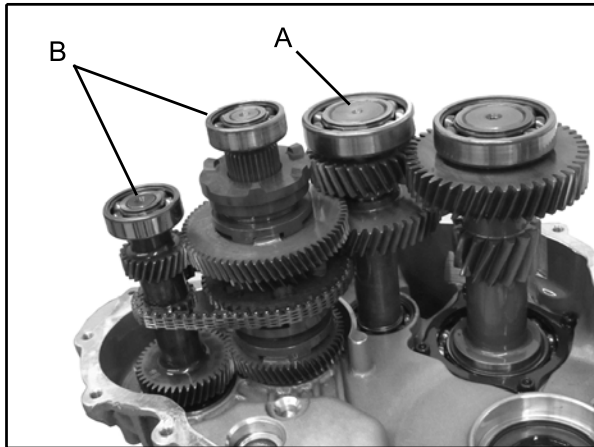

20. Install the rear output shaft assembly (C).

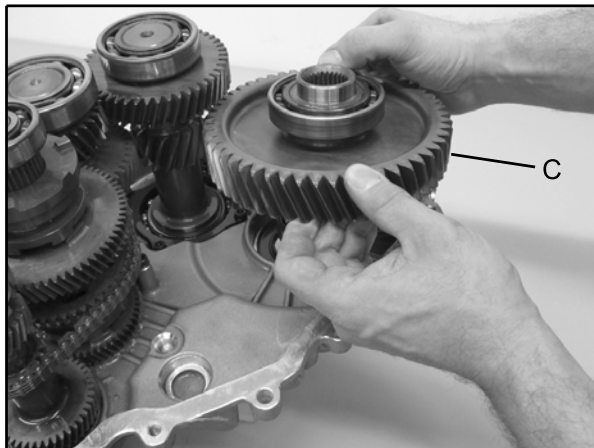

21. Assemble the shift shaft rail if previously disassembled.

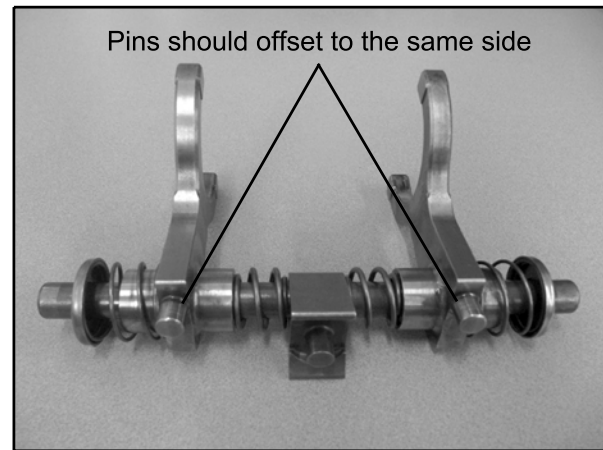

**NOTE:** Both shift forks need to be orientated the same way, so that the shift fork pins are both offset to the same side of the rail.

22. Install the shift shaft rail (D) and shift forks into the transmission housing as an assembly. Be sure the shift forks are engaged into the engagement dogs.

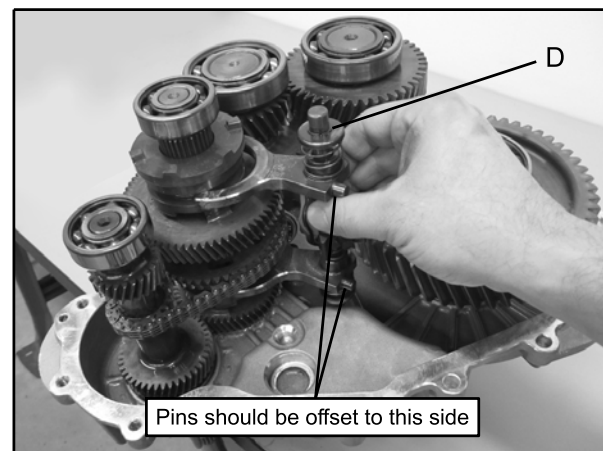

**NOTE:** Shift fork pins should be offset towards the input shaft as shown above.

# TRANSMISSION

23. Inspect the shift drum for any damage or wear. Inspect the splines of the shift drum.

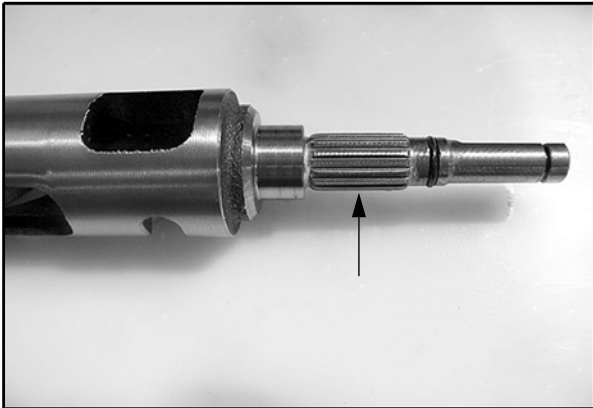

24. Install the shift drum (E) into the transmission housing. Lift up on the shift shaft rail (D) and move the rail assembly towards the shift drum to allow the shift fork ends to be installed into the shift drum (E).

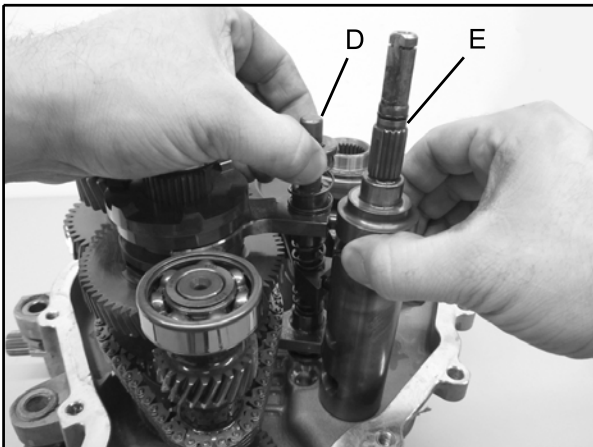

25. Apply a continuous bead of Crankcase 3 Bond Sealant (PN 2871557) to left-hand transmission mating surface.

26. Install the transmission case cover and retaining bolts. Torque bolts to specification.

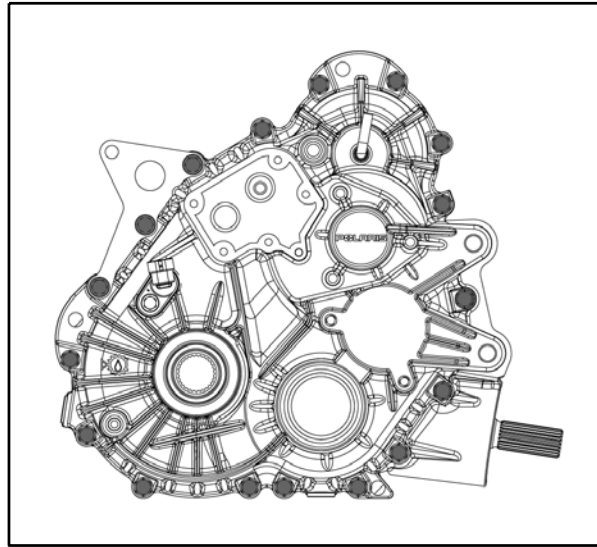

Transmission Case Bolts:  
**20 ft-lbs (27 Nm)**

27. Install new seals into the transmission case halves.

- The snorkel shaft seal (F), should be pressed in until it seats against the housing counter-bore.
- The input shaft seal (G), should be pressed in until it seats flush with the housing.
- The rear output shaft seals (H), can be installed using a standard bushing installation tool. Seals should be installed just past the case lead-in chamfer (.070" or 1.8 mm from outer face of bore).

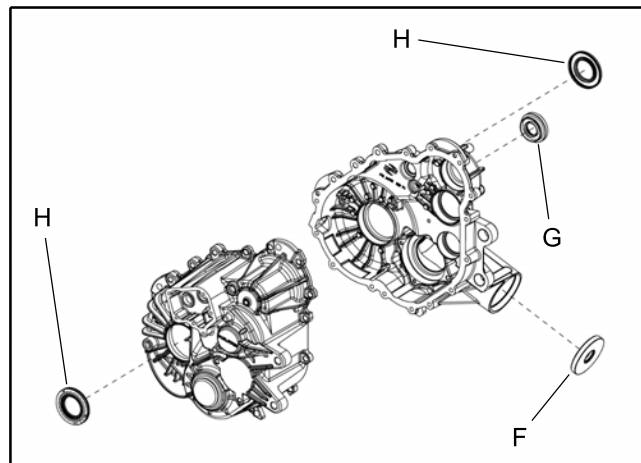

28. Thoroughly clean the shift shaft housing. **Be sure the transmission is in High gear prior to reassembly.**

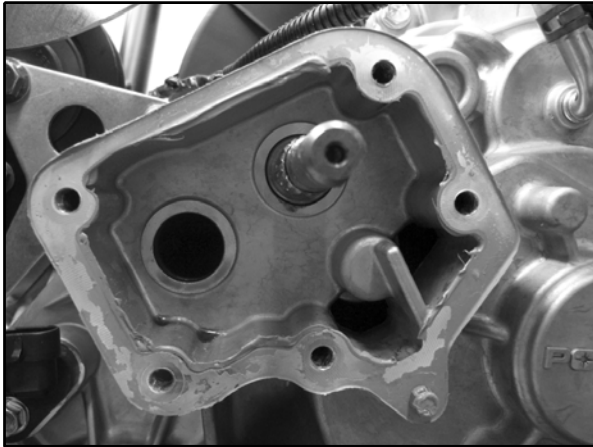

29. Install the sector gear (16T) onto the shift drum shaft. Install the shift shaft assembly and sector gear (11T) into the bushing pocket on the left side. Align the timing marks on the gears as shown.

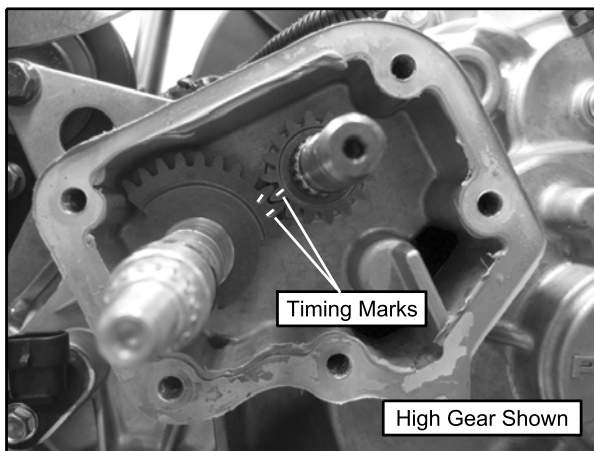

30. Install the spacer onto the shift drum shaft.

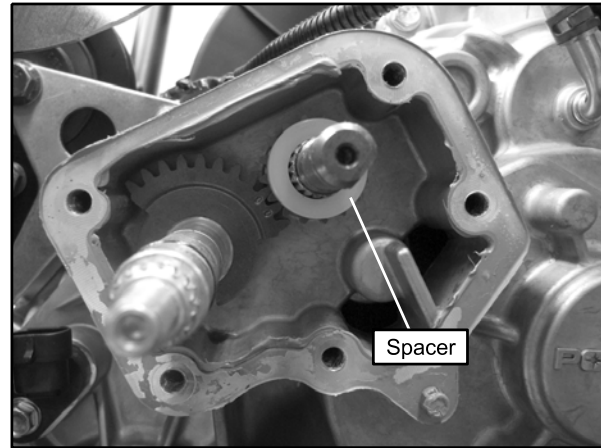

31. Install the detent star onto the shift drum shaft. Be sure to install the detent star with the raised edge facing outward and skip-tooth aligned.
32. Install the detent pawl onto the shift shaft and carefully install the compression spring.

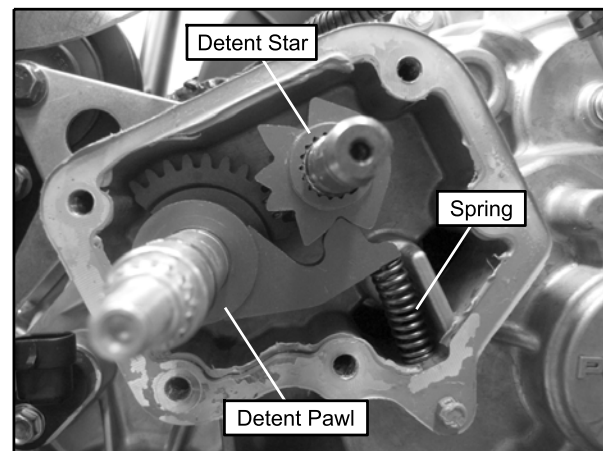



# TRANSMISSION

33. Install a new O-ring on each shift shaft. Apply a small amount of white lithium grease on the O-rings, shift shafts and component contact surfaces prior to installing the sector cover.

39. Refer to "Transmission Installation" to complete the repair.

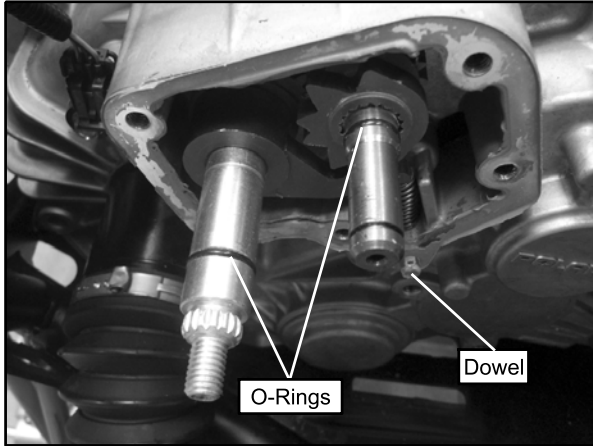

- 34. Clean the transmission and gear sector cover mating surfaces thoroughly.
- 35. Apply Crankcase Sealant (3-Bond) (PN 2871557) onto the cover and transmission case mating surface.
- 36. Install the sector cover and align the transmission case dowel with the alignment hole. Install and torque the bolts to specification.

 = T
Sector Gear Cover Bolts: <b>12 ft-lb (16 Nm)</b>

37. Install the transmission drain plug and torque to specification.

 = T
Fill / Drain Plug: <b>14 ft-lbs (19 Nm)</b>

38. Install the bellcrank onto the shift shaft. Note the key splined on the bellcrank and shift shaft. Install the nut and torque to specification.

 = T
Bell Crank Nut: <b>18 ft-lb (24 Nm)</b>

## TRANSMISSION SERVICE (INT'L)

### Differential Operation

The INT'L transmission has two traction operational modes: Differential Lock and Differential Unlock. Locking the rear differential is beneficial in low traction and rough terrain conditions. Unlocking the rear differential makes maneuvering easier and minimizes damage to terrain.

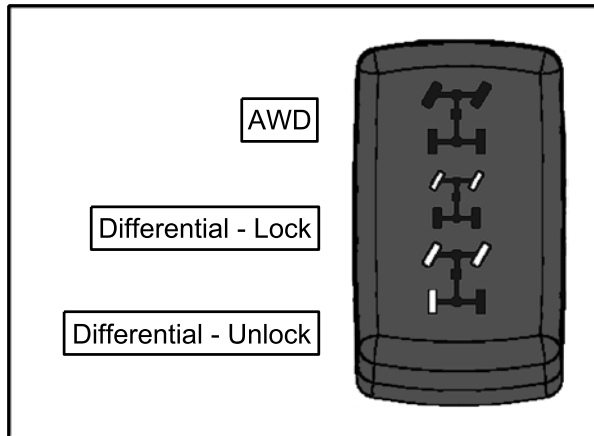

When "Differential-Unlock" is selected, the rear differential becomes unlocked for tighter turns. An electrical solenoid mounted in the rear portion of the gearcase actuates the shift fork. The solenoid plunger extends out to move the fork and slides the engagement dog away from the side gear that is part of the planetary differential assembly. This unlocks the rear differential. The rear drive shafts are now dependent on the differential allowing for tighter turns.

When switch position is set to "Unlock" the solenoid is powered and the plunger extends to disengage the side gear and unlock the differential.

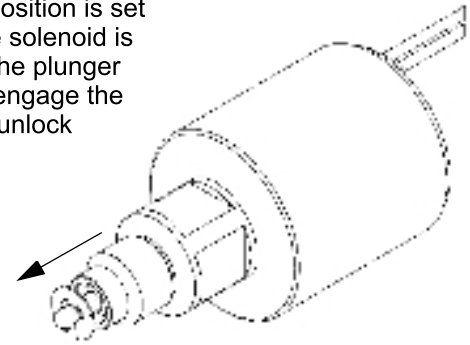

When "Differential-Lock" is selected, power is removed from the electrical solenoid allowing the solenoid plunger to retract. Spring tension moves the shift fork back into place and mates the engagement dog to the side gear that is part of the planetary differential assembly. This locks the rear differential as a solid rear axle, increasing traction.

When switch position is set to "lock", power is removed from the solenoid and spring tension retracts the plunger to engage the clutch gear and lock the differential.

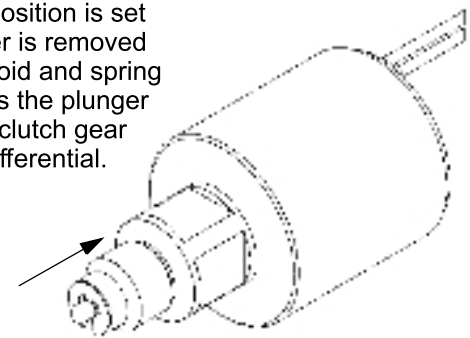

# TRANSMISSION

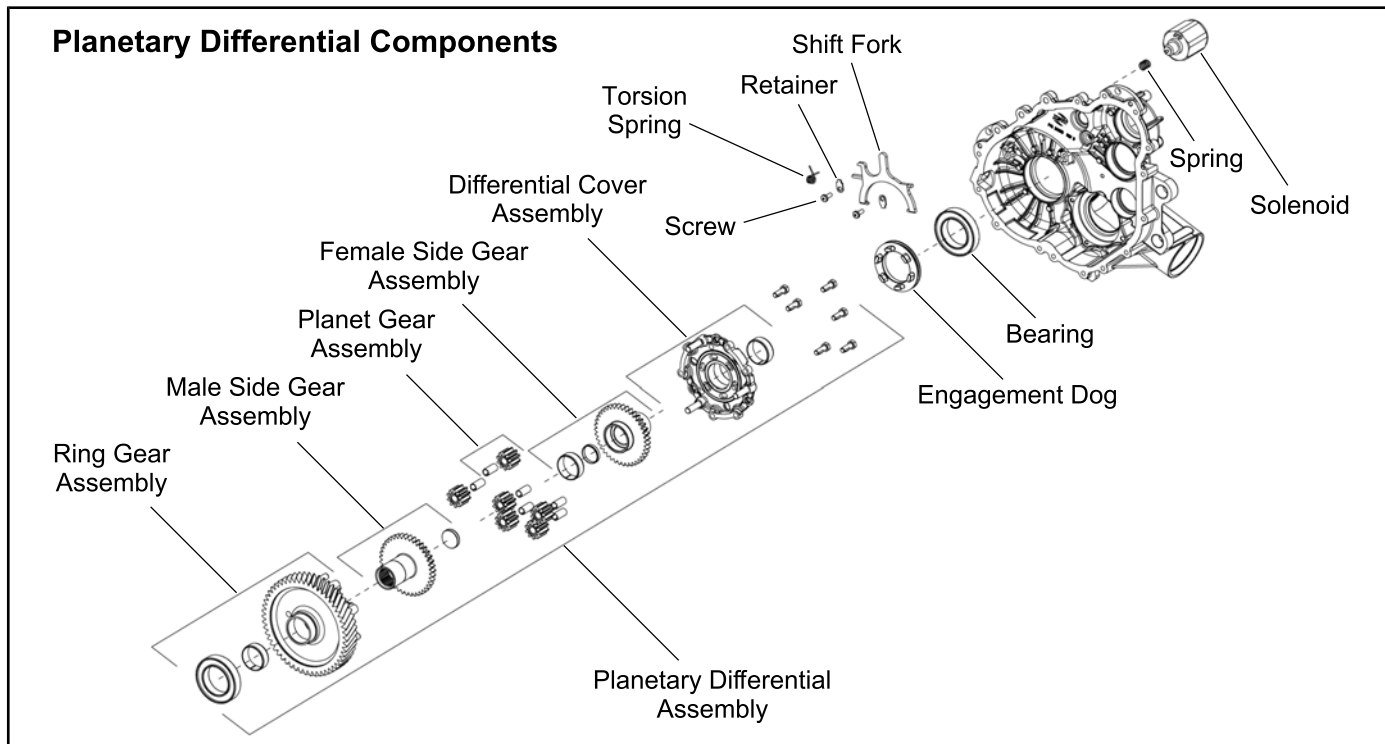

## Transmission Disassembly

**NOTE:** Refer to the exploded view at the end of this chapter as a reference.

1. Place transmission in High gear before disassembly.
2. Drain and properly dispose of the transmission lubricant (see Chapter 2).
3. Remove the bellcrank nut (Item 1) and bellcrank (Item 2).

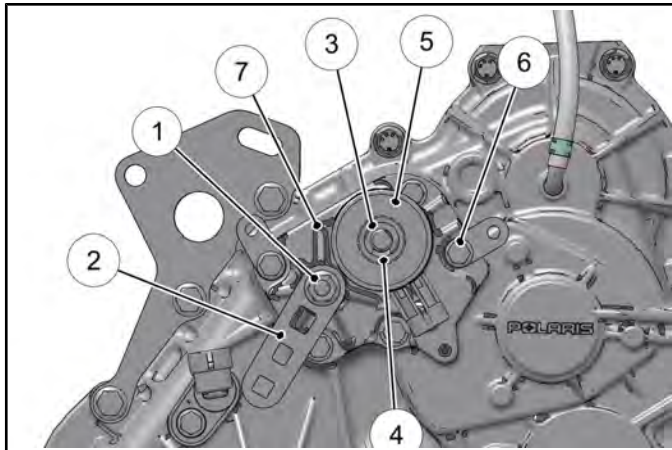

4. Remove E-clip (Item 3) that retains spring washer (Item 4), flat washer (Item 4) and gear switch (Item 5). Remove the switch.

5. Remove the sector cover bolts (Item 6) and remove the sector cover (Item 7).

**NOTE:** Removal can be aided by using your thumbs to press in on the shafts while pulling out the cover with your fingers.

6. Remove the compression spring (H).

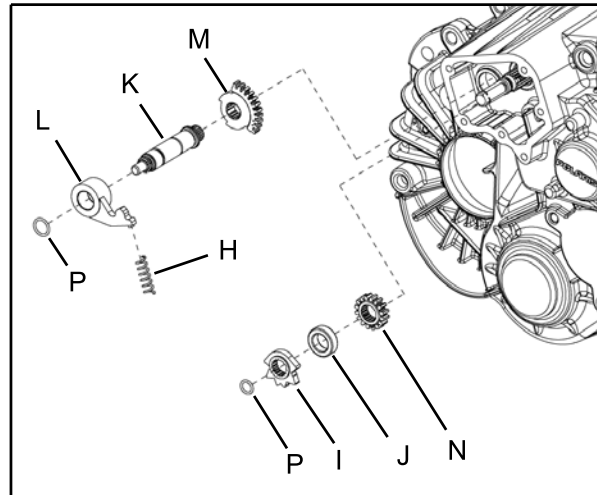

7. Remove the detent star (I). Note how the detent star fits onto the splined shaft with the raised edge facing outward for reassembly.
8. Remove the spacer (J).

## TRANSMISSION

9. Remove the shift shaft (K), detent pawl (L) and the shift sector gears (M and N).

**NOTE:** Note the timing marks on the shift gears (M and N) for reassembly purposes.

10. Remove the O-rings (P) from each shaft and discard. Use new O-rings upon assembly.
11. Remove the bolt and washer retaining the brake disc to transmission pinion shaft. Remove disc from shaft.
12. Remove all transmission case bolts. Using suitable pry bars, remove the cover using the designated pry points (indicated by black arrows in illustration below).

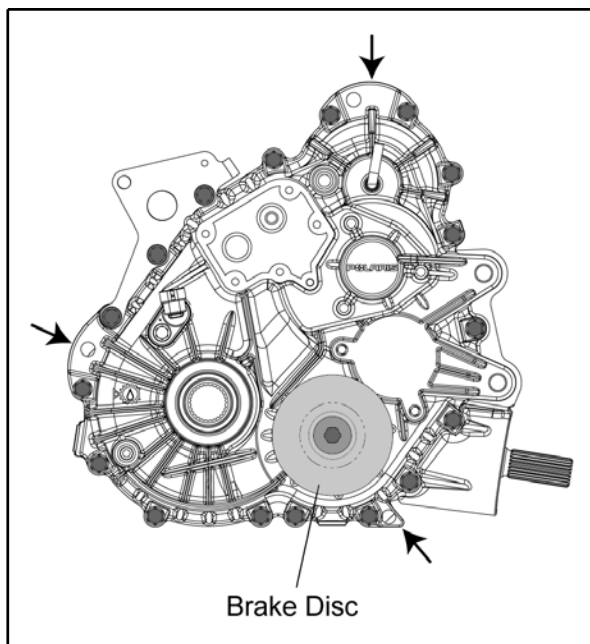

### CAUTION

Do not pry on case sealing surfaces.  
Use only the designated pry points  
on the transmission.

13. Lift up on the shift shaft rail (Q) and move the rail assembly rearward to allow the shift fork pins to be removed from the shift drum (R). Remove the shift drum (R) from the transmission housing.

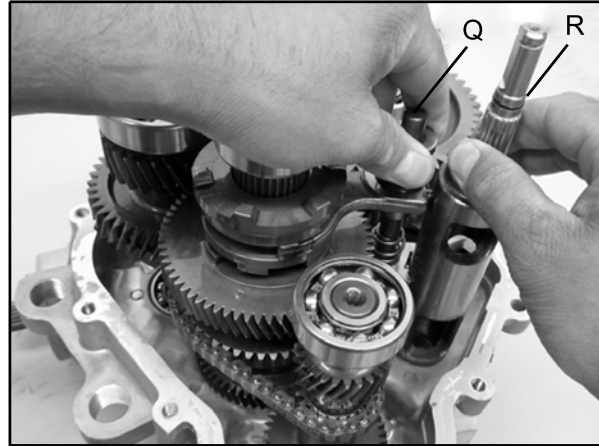

14. Remove the shift shaft rail (Q) and shift forks from the transmission housing as an assembly.



## TRANSMISSION

15. Remove the rear output shaft assembly (S) by lifting underneath the gear or by tapping the shaft from the opposite side. If use of a pry bar is necessary, take care not to pry on sealing surfaces of case.



19. Remove (2) screws and retaining plates, then lift shift fork (Y) and torsion spring out of transmission housing.

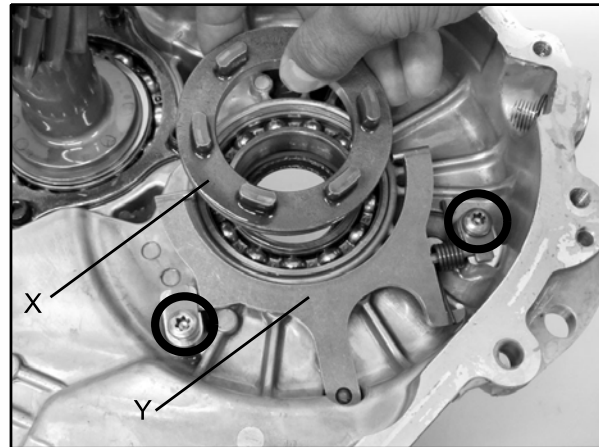

16. Remove the idler gear shaft assembly (T) and gear cluster assembly (U) from the transmission housing by pulling both assemblies straight up.

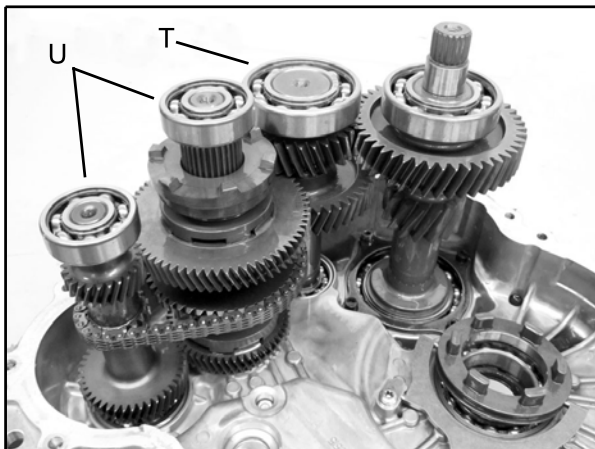

20. Using a 5 mm Allen wrench, remove the screws that secure the pinion shaft assembly (V). Lift the pinion shaft assembly straight up to remove it from the housing. Note the longer screw (W) that locks the snorkel tube.



17. Place the idler gear shaft assembly (T) and gear cluster assembly (U) on a clean surface for inspection. If disassembly is required, refer to "Gear Cluster Disassembly".

21. Remove all seals from the gearcase halves and clean the cases in preparation for assembly.

18. Slide engagement dog (X) off of shift fork guides.

### Gear Cluster Disassembly

# TRANSMISSION

22. Remove the bearing from the reverse shaft using a bearing puller. Remove the retaining ring and slide the washers, 53T gear and needle bearing off the reverse shaft (see Figure 8-1).

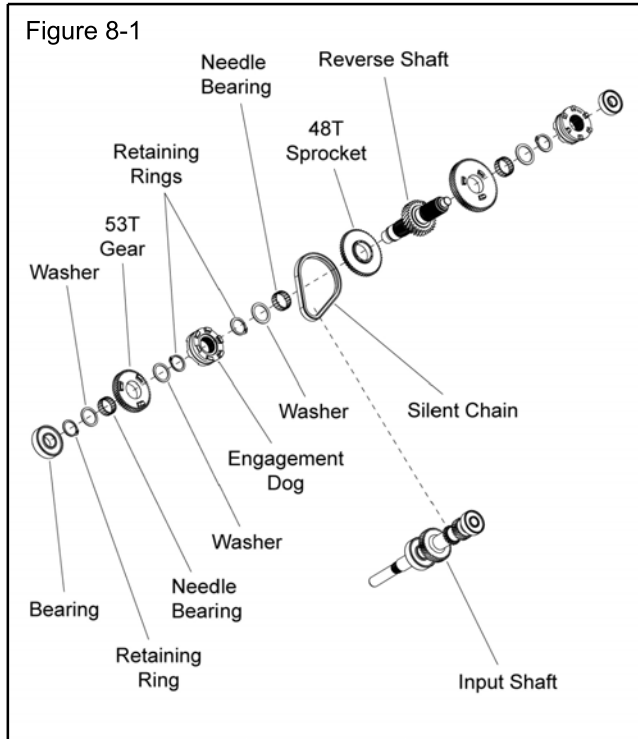

23. Remove the retaining ring and engagement dog from the reverse shaft (see Figure 8-1).
24. Remove the retaining ring, washer, needle bearing, and sprocket from the reverse shaft (see Figure 8-1).
25. Tilt the two shafts towards each other and remove the silent chain from the two shafts.

26. If necessary, disassemble the other end of the reverse shaft. Remove the bearing, engagement dog, retaining ring, washer, gear and needle bearing from the reverse shaft (see Figure 8-2).

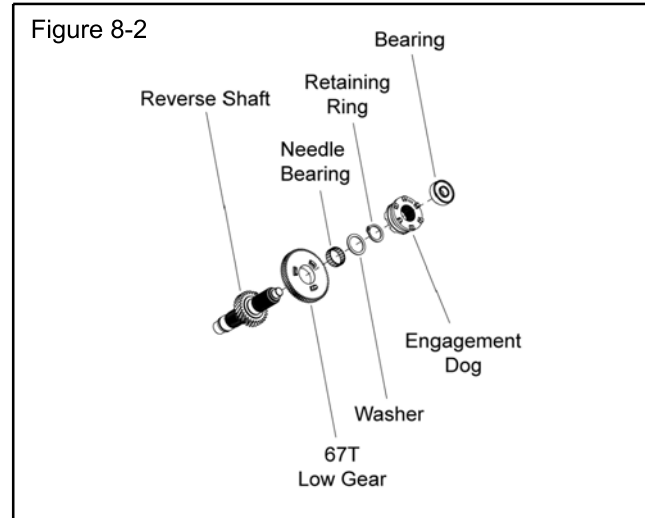

27. To disassemble the shift shaft rail remove the snap ring (X) from the end of the shift rail on either side.

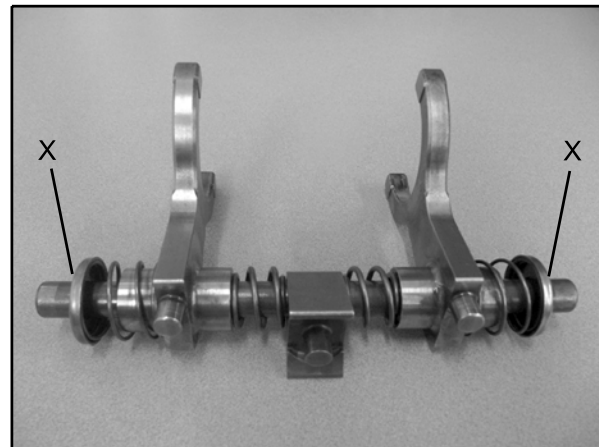

## CAUTION

Use caution when disassembling the shift rail. The compressed springs on the shift rail may pop off causing eye or face injury.

Snorkel Shaft Removal / Disassembly

# TRANSMISSION

**⚠ CAUTION**

The pinion shaft must be removed prior to removing the snorkel shaft assembly. Failure to remove pinion shaft, will result in damage to the snorkel shaft.

28. Extract the seal from the snorkel shaft to access the snorkel tube for removal.

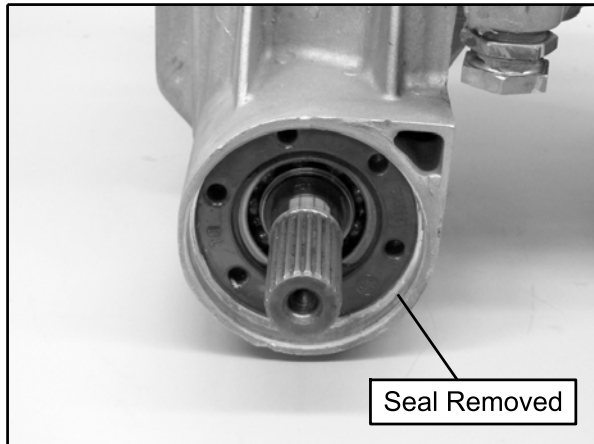

29. Using the Snorkel Tool (PA-50231), fully loosen the snorkel tube.

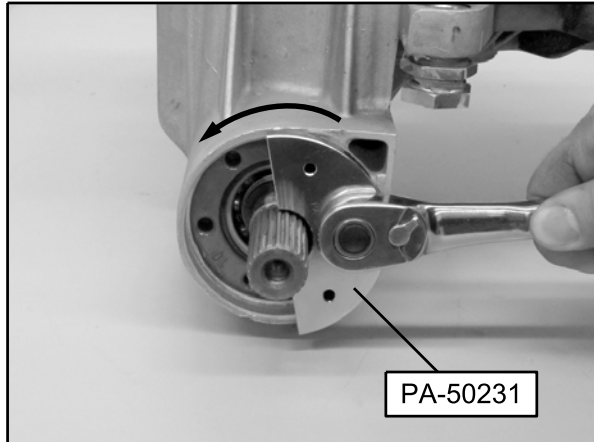

30. Remove the snorkel tube and shaft assembly from the transmission case.

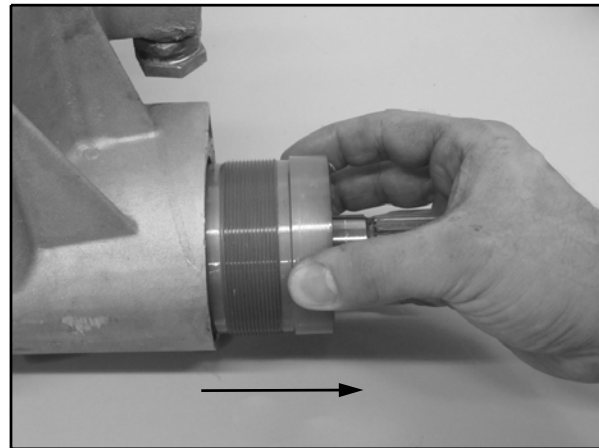

31. Remove the snap ring (Y) and shim (Z) from the snorkel shaft.

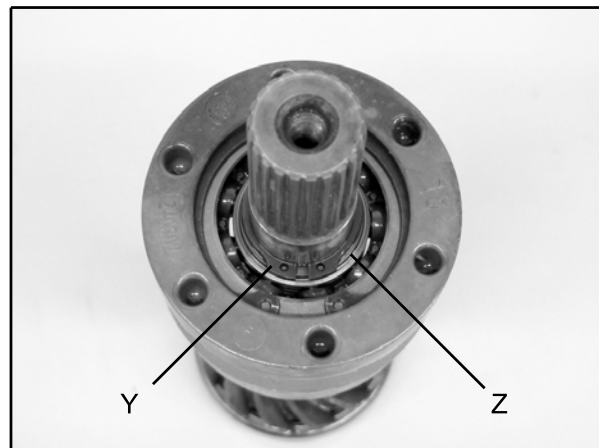

32. Use an arbor press to remove the snorkel tube from the snorkel shaft.

33. Remove the snap ring (A) and shim (B) retaining the bearing in the snorkel tube.

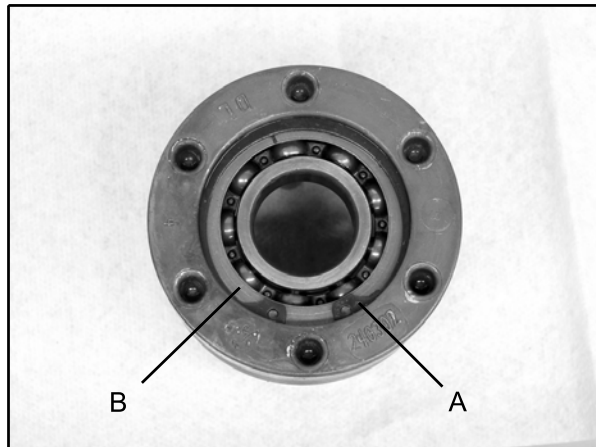

34. Lightly tap on the bearing from the opposite side to remove it from the snorkel tube.

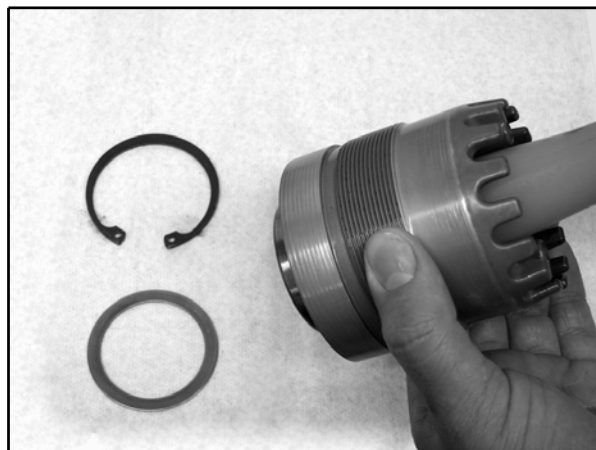

35. Remove the retaining ring to remove the remaining washer, bearing and gear from the snorkel shaft.

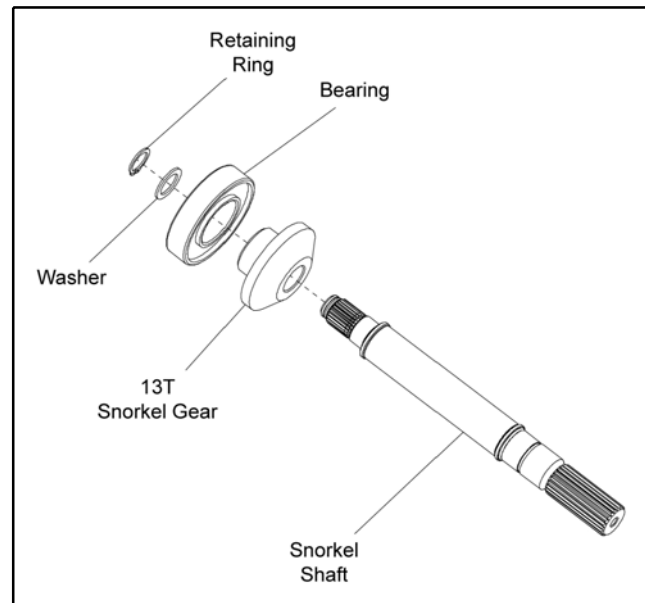

## Planetary Differential Disassembly

**NOTE:** If the gearcase is completely assembled, perform the "Gearcase Disassembly and Inspection" procedure.

1. Use a scribe to mark the differential cover and ring gear prior to disassembly.

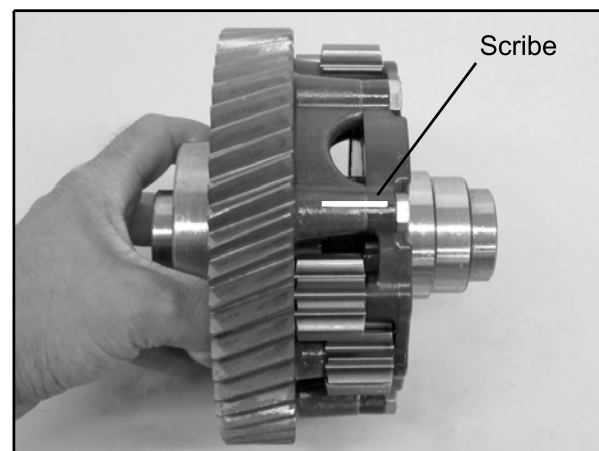



## TRANSMISSION

2. Remove the six screws retaining the differential cover and remove the cover.



3. Remove the six planet gears and each side gear assembly from the ring gear.

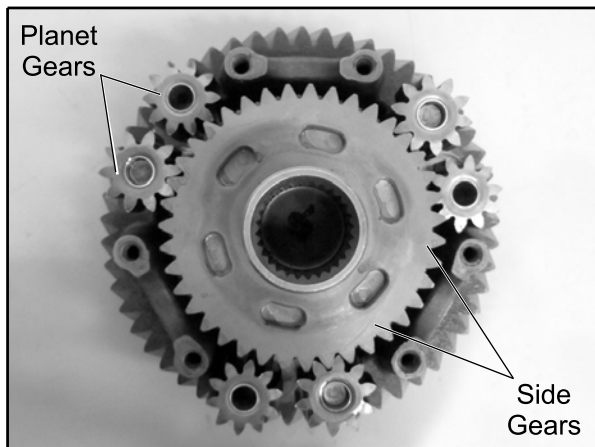

4. Inspect the female side gear (A), male side gear (B), planet gears (C) and ring gear (D). Replace components or bushings as needed. Bushing replacement can be performed on all necessary differential components. If bushing replacement is required, proceed to "Planetary Differential Bushing Replacement".

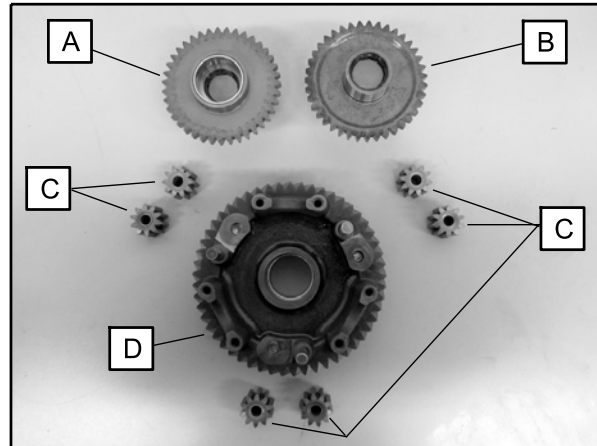

### Planetary Differential Bushing Replacement

**NOTE:** If the differential is completely assembled, perform the "Planetary Differential Disassembly" procedure.

#### Ring Gear Bushing Replacement

1. Press the old bushing out of the ring gear.
2. Thoroughly clean the bore of the ring gear and check for any unwanted burrs.

3. Press the new bushing into the ring gear housing.

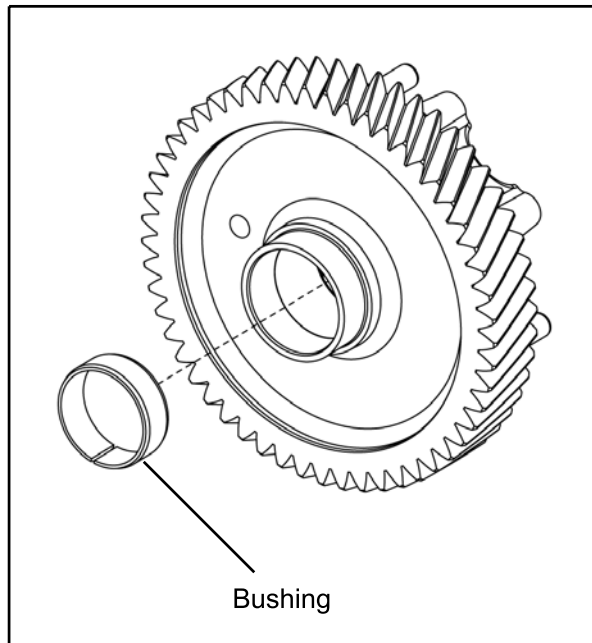

4. Install the bushing to the specified depth as shown.

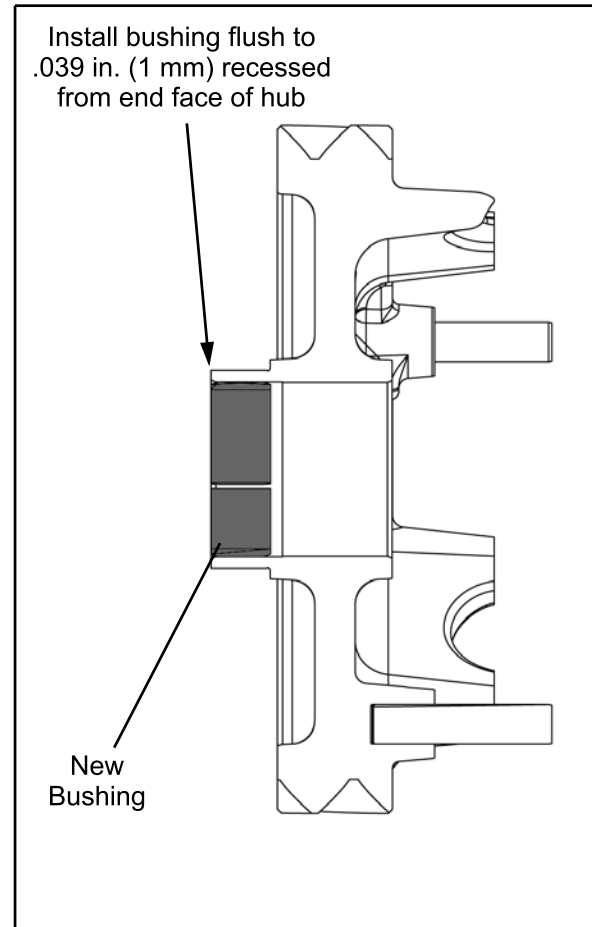

## Planet Gear Bushing Replacement

5. Press the old bushing out of the planet gear.
6. Thoroughly clean the bore of the planet gear and check for any unwanted burrs.

# TRANSMISSION

7. Press the new bushing into the planet gear until it is flush on each end. Repeat this procedure for the remaining planet gears.

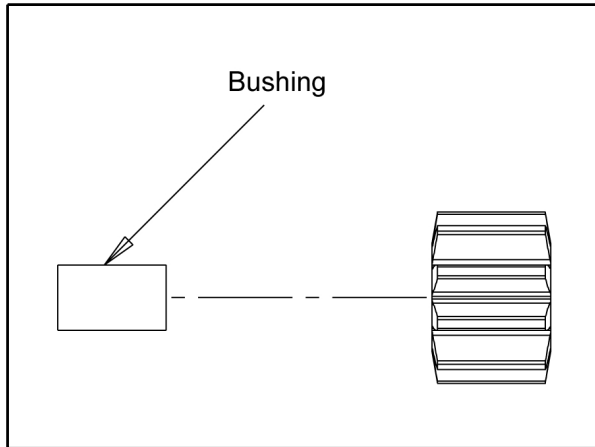

## Differential Cover Bushing Replacement

8. Press the old bushing out of the differential cover.
9. Thoroughly clean the bore of the differential cover and check for any unwanted burrs.
10. Press the new bushing into the differential cover.

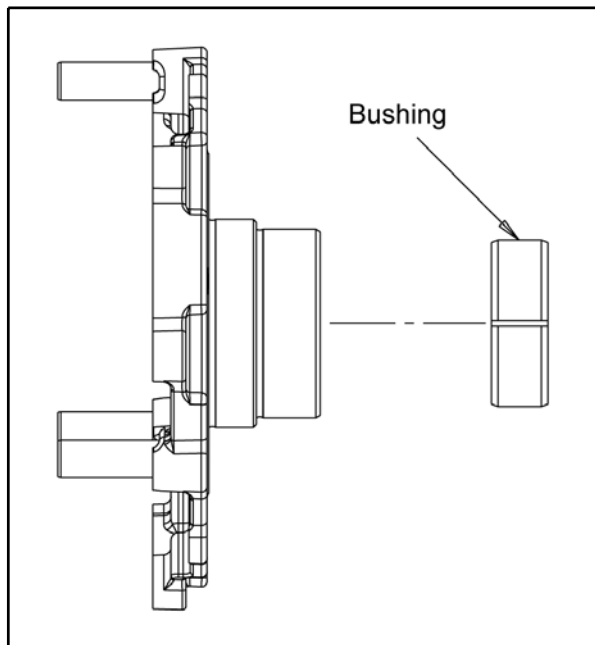

11. Install the bushing to the specified depth as shown.

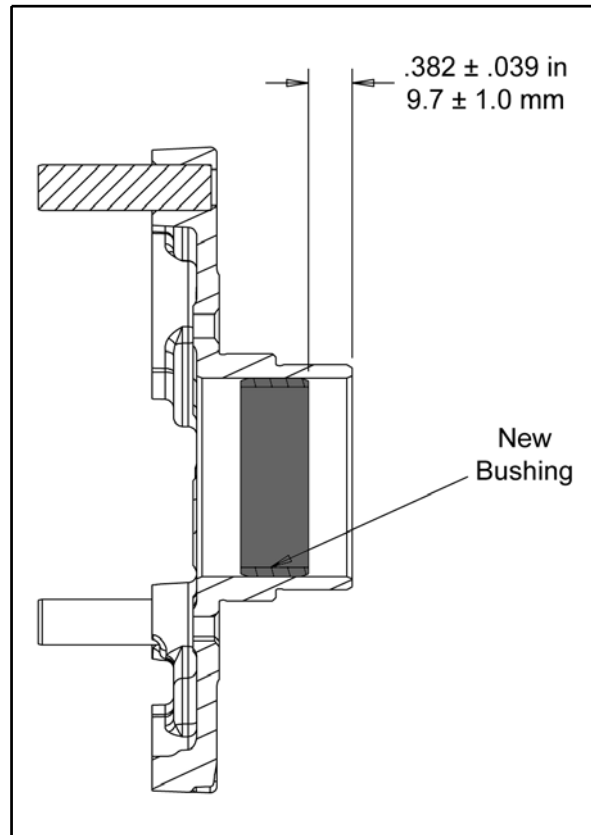

## Female Side Gear Bushing Replacement

12. Locate the bushing split. Using a small chisel or flat blade screwdriver, peel back and remove the old bushing from the side gear, being careful not to damage the side gear.

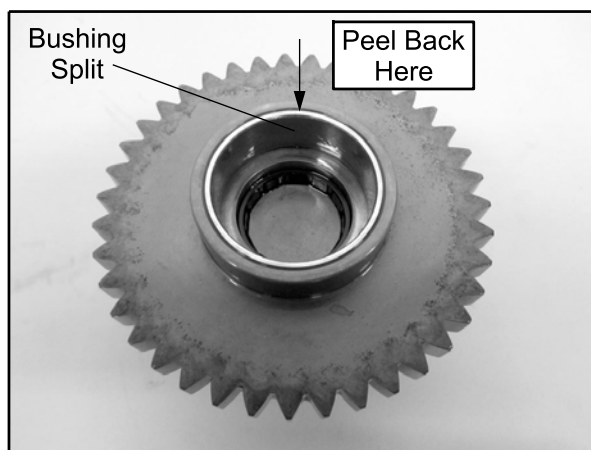

13. Thoroughly clean the bore of the side gear and check for any unwanted burrs.

14. Press the new bushing into the side gear until it bottoms out.

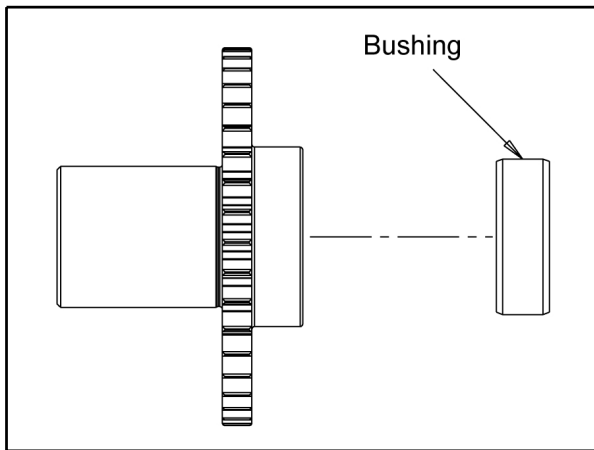

3. Align and install the differential cover using the previously made scribe marks.
4. Apply Loctite® 2760™ to cover screws.
5. Install screws hand tight. Place assembly in soft jaw vise and torque to specification.



## Planetary Differential Assembly

1. Thoroughly clean the differential components.
2. Assemble the side gears and place them onto the ring gear along with the (6) planet gears.

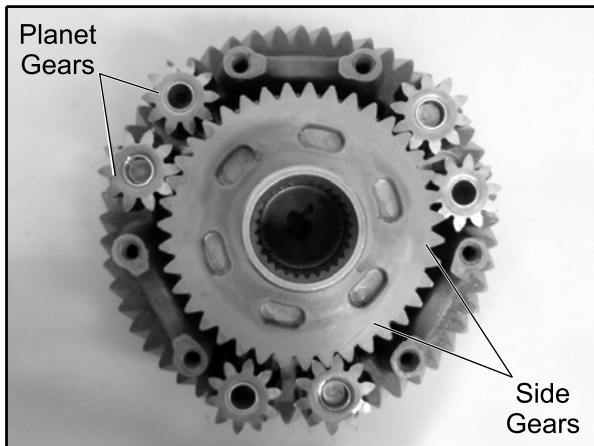

Differential Cover Screws:  
**22 ft-lb (30 Nm)**

# TRANSMISSION

## Gear / Shaft / Bearing Inspection

Inspect all gear sets and shafts for excessive wear or damage.

**IMPORTANT:** If gear replacement is required, be sure to also replace the corresponding gear or gear shaft.

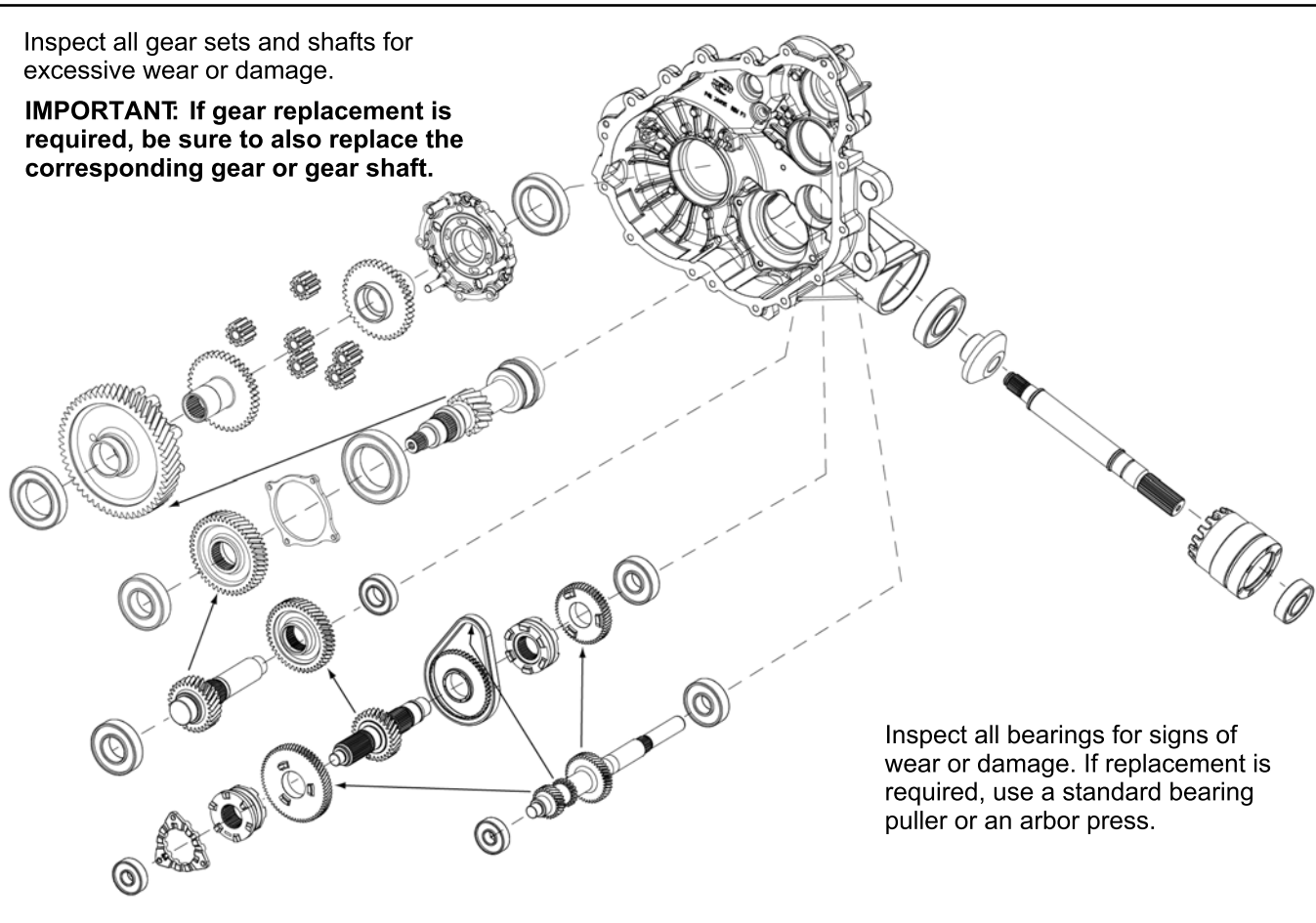

Inspect all bearings for signs of wear or damage. If replacement is required, use a standard bearing puller or an arbor press.

## Snorkel Gear Backlash Procedure

1. Reassemble the snorkel tube and snorkel shaft assembly by reversing the disassembly procedure (see "Snorkel Shaft Removal / Disassembly").

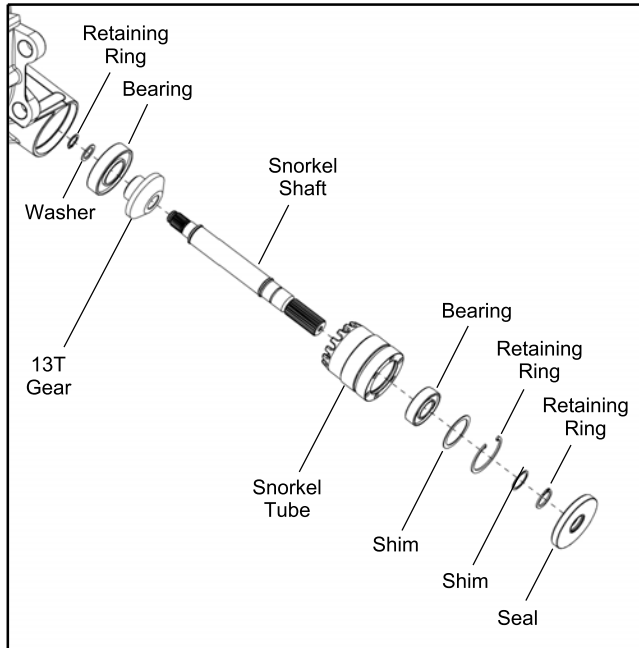

2. After the 13T gear and bearing are pressed onto the snorkel shaft (flush to the shoulder), install the washer and new retaining ring.
3. Press the gear back towards the retaining ring. Avoid excessive force so the retaining ring is not damaged or pre-stressed significantly.

**NOTE: Failure to press the gear back against the washer and retaining ring will lead to a gear backlash change after vehicle is placed into service.**

4. Apply a small amount of white lithium grease or Anti-Seize on the threads of the snorkel tube.

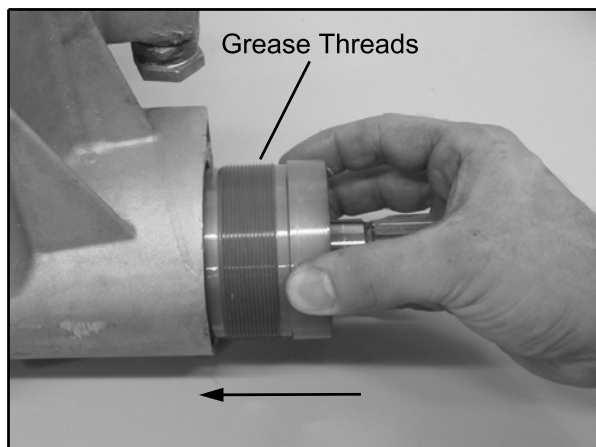

5. Install the snorkel shaft into the gearcase. Using the Snorkel Tool (PA-50231), tighten the snorkel tube until it is lightly seated in the transmission housing.

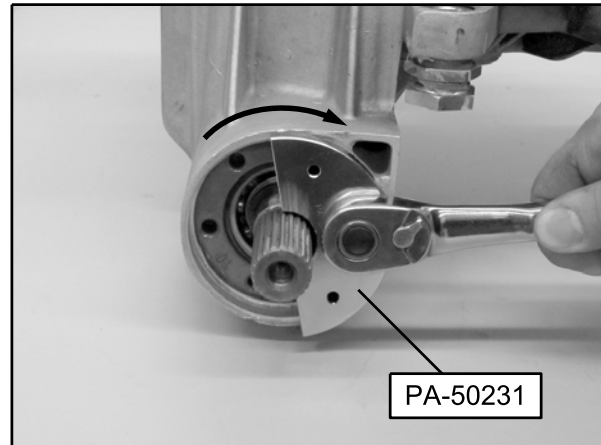

6. Inspect the pinion shaft assembly. Replace bearings if needed. Inspect each gear for damage, chips or abnormally worn teeth.

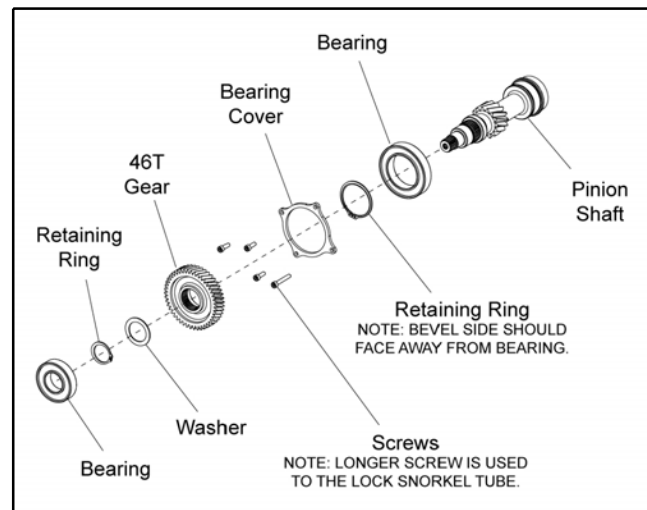

**NOTE: If pinion shaft was disassembled, the bearing cover must be installed on the shaft before installing the 46T gear.**

7. Install the pinion shaft assembly. Be sure to properly mesh the snorkel shaft bevel gear with the pinion shaft bevel gear.
8. Apply Loctite® 242™ to the threads of the bearing cover retaining screws.

# TRANSMISSION

9. Using a 5 mm Allen wrench, install only the (3) screws that secure the pinion shaft assembly as shown below. Leave the longer locking screw (A) out at this point.



**NOTE: DO NOT install the longer screw (A). Installing the longer screw will lock the snorkel tube and not allow for backlash setting adjustment.**

10. Torque the bearing cover retaining screws to specification.

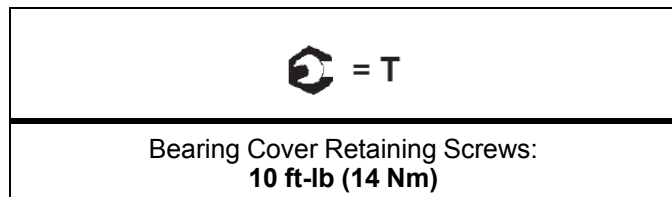

11. Rotate the snorkel tube *counterclockwise* using the snorkel tool (PA-50231) until the snorkel gear and pinion gear have 'zero' backlash.

**NOTE: DO NOT overtighten the snorkel tube when backing it out. At the 'zero' backlash position, you should still be able to turn the snorkel shaft using your fingers, but it will feel rough and may have some tight spots.**

12. Look down into the transmission housing to see the snorkel locking screw hole opening to reference your starting point.

**NOTE: If you have a hard time seeing into the hole, insert a small Allen wrench, punch or screwdriver into the hole to feel when the notch is aligned with the hole.**

13. Slowly rotate the snorkel tube *clockwise* while counting the number of notches passing through the hole opening as you rotate the tube. Rotate the snorkel tube to the **3rd** notch from the 'zero' backlash position obtained in step 11.

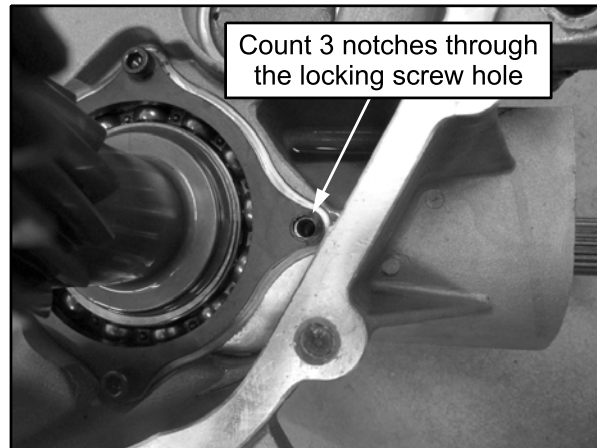

14. Check the pinion shaft gear backlash again by feel. If the pinion shaft gear lash appears to be too tight, rotate the snorkel shaft *clockwise* to the next notch (4th notch).

15. Once the backlash is set, apply Loctite® 242™ to the threads and install the locking screw to secure the snorkel tube.

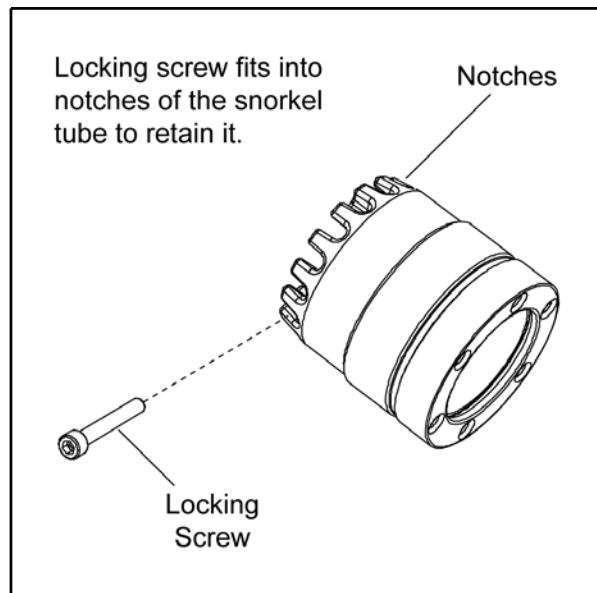

## TRANSMISSION

16. Torque the locking screw to specification.

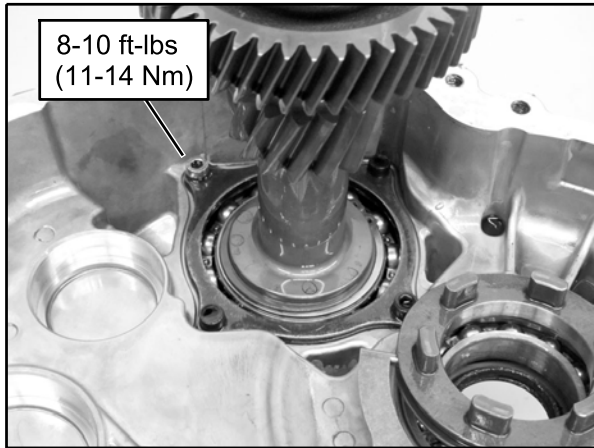

Snorkel Locking Screw:  
**10 ft-lb (14 Nm)**

Transmission Assembly

**NOTE: The snorkel shaft and pinion shaft must be installed prior to transmission assembly. The snorkel shaft cannot be installed after assembling the transmission.**

17. Clean both transmission case halves thoroughly. Inspect case half mating surfaces for damage.
18. Install shift fork (S) and torsion spring into transmission housing as an assembly. Load spring as shown in image below

19. Apply Loctite® 242™ to (2) screws (T) and install with retaining plates over shift fork. Torque to specification.

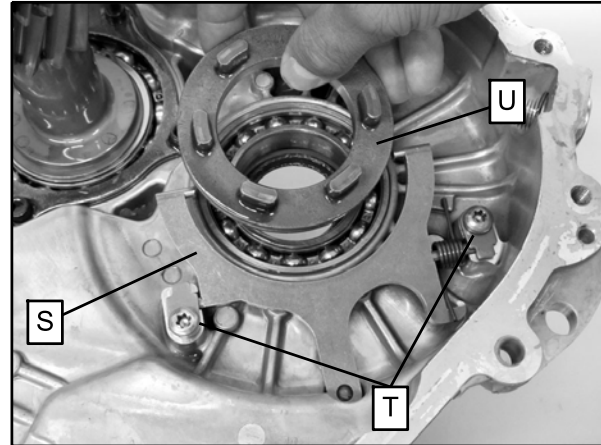

Shift Fork Screws:  
**10 ft-lb (14 Nm)**

20. Slide engagement dog (U) onto retaining pins of shift fork.



# TRANSMISSION

21. Assemble the reverse shaft assembly and input shaft assembly if previously disassembled (see illustrations).

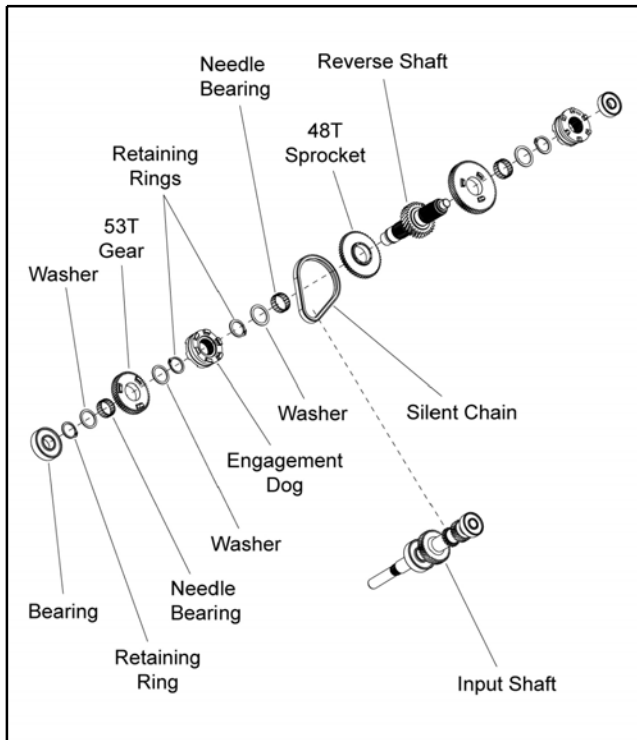
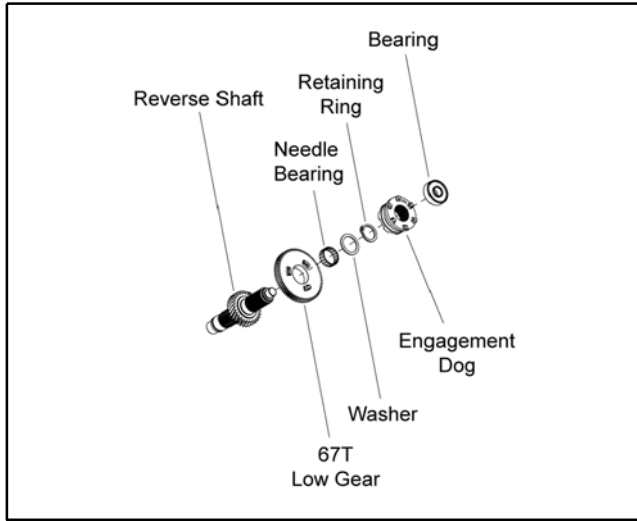

22. Install the idler gear shaft assembly (A) and gear cluster assembly (B) into the transmission housing, all at the same time.

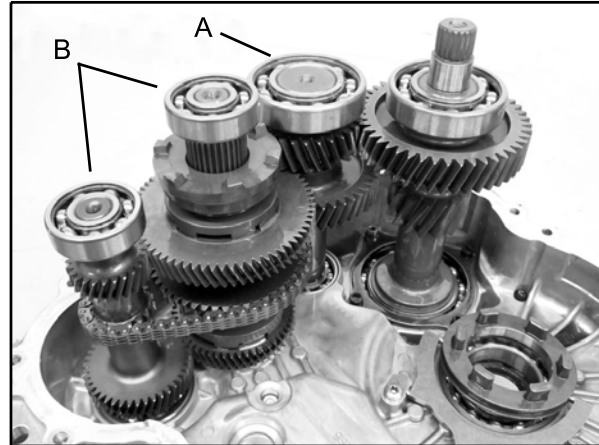

23. Install the rear output shaft assembly (C). Rotate output shaft assembly to align slots with engagement dog. Ensure bearing is fully seated upon assembly.

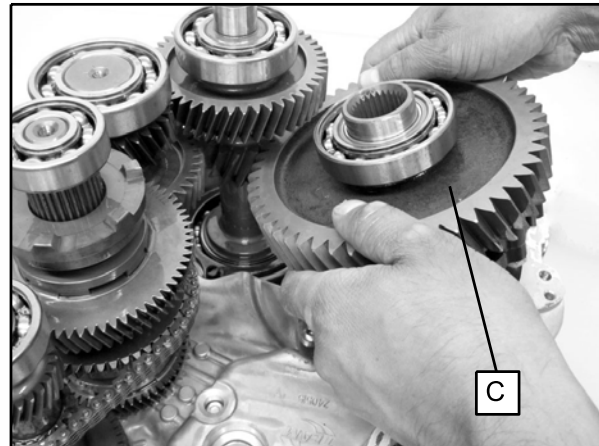

## TRANSMISSION

24. Assemble shift shaft rail if previously disassembled.

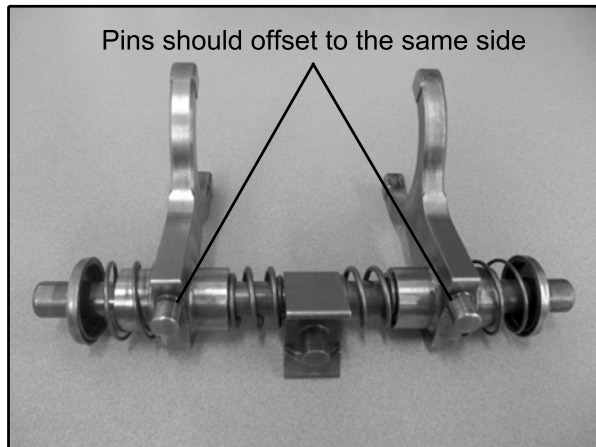

**NOTE:** Both shift forks need to be orientated the same way, so that the shift fork pins are both offset to the same side of the rail.

25. Install the shift shaft rail (D) and shift forks into the transmission housing as an assembly. Be sure the shift forks are engaged into the engagement dogs.

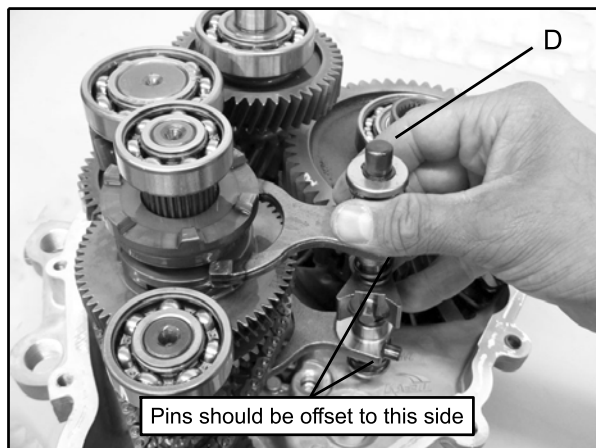

**NOTE:** Shift fork pins should be offset towards the input shaft as shown above.

26. Inspect the shift drum for any damage or wear. Inspect the splines of the shift drum.

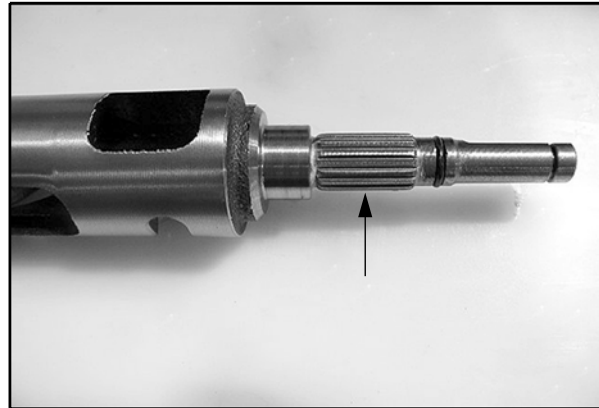

27. Install the shift drum (E) into the transmission housing. Lift up on the shift shaft rail (D) and move the rail assembly towards the shift drum to allow the shift fork ends to be installed into the shift drum (E).

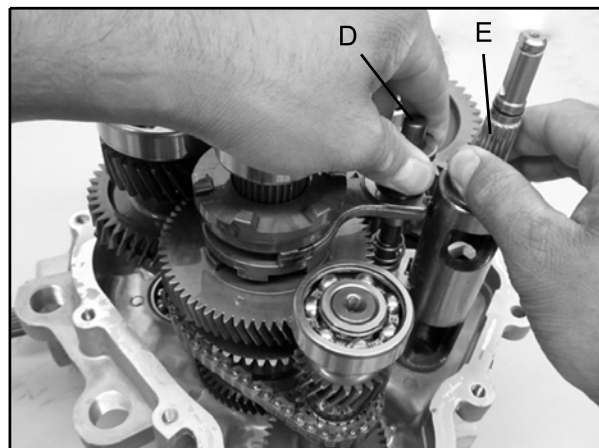

28. Apply a continuous bead of Crankcase 3 Bond Sealant (PN 2871557) to the left hand transmission mating surface.

# TRANSMISSION

29. Install the transmission case cover and retaining bolts. Torque bolts to specification.

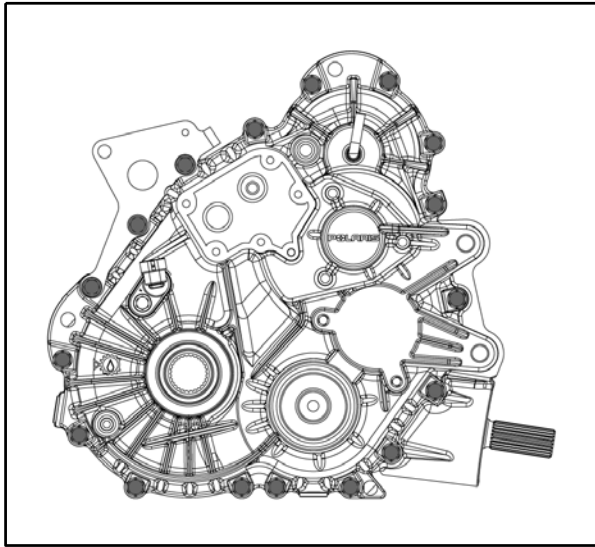

Transmission Case Screws:  
**20 ft-lbs (27 Nm)**

30. Install new seals into the transmission case halves.

- The snorkel shaft seal (F), should be pressed in until it seats against the housing counter-bore.
- The input shaft seal (G), should be pressed in until it seats flush with the housing.
- The rear output shaft seals (H) and pinion shaft seal (J) can be installed using a standard bushing installation tool. Seals should be installed just past the case lead-in chamfer (.070" or 1.8 mm from outer face of bore).

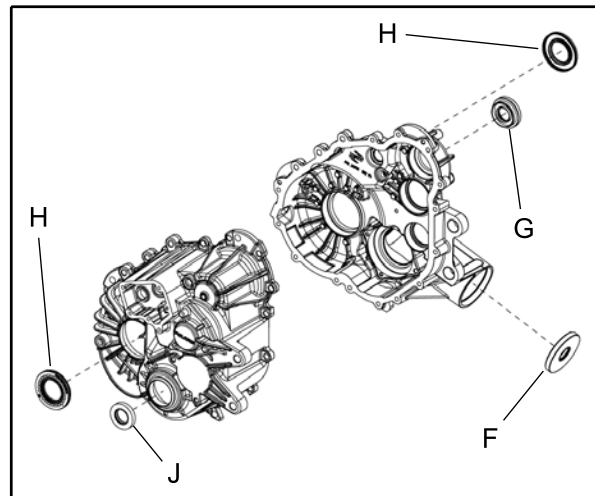

## TRANSMISSION

31. Install the brake disc onto the pinion shaft. Install the washer and apply Loctite® 262™ or 2760™ to the mounting bolt threads. Torque the bolt to specification.

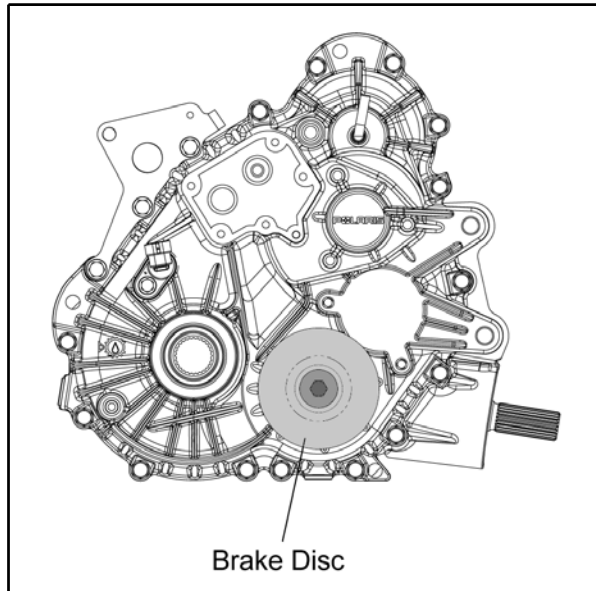

Park Brake Disc Mounting Bolt:  
14 ft-lb (20 Nm)

32. Thoroughly clean the shift shaft housing. **Be sure the transmission is in High gear prior to reassembly.**

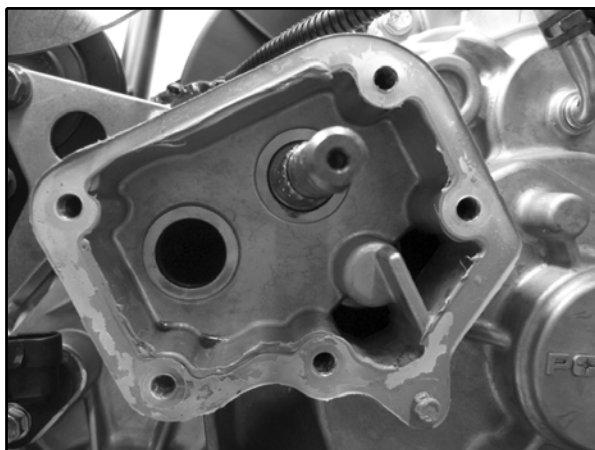

33. Install the sector gear (16T) onto the shift drum shaft. Install the shift shaft assembly and sector gear (11T) into the bushing pocket on the left side. Align the timing marks on the gears as shown.

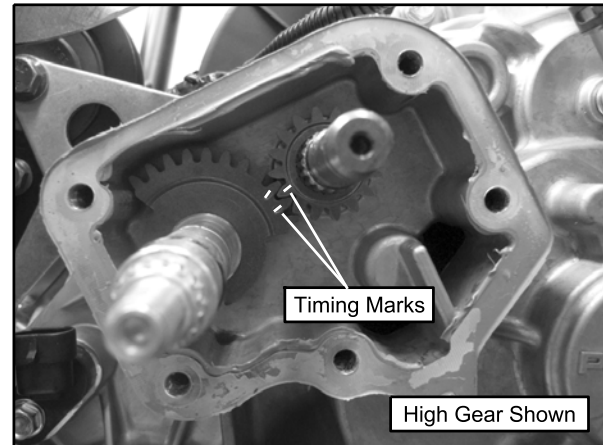

34. Install the spacer onto the shift drum shaft.

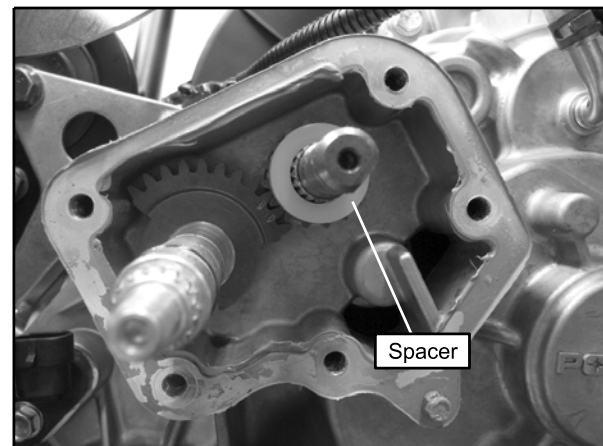

35. Install the detent star onto the shift drum shaft. Be sure to install the detent star with the raised edge facing outward and skip-tooth aligned.

# TRANSMISSION

36. Install the detent pawl onto the shift shaft and carefully install the compression spring.

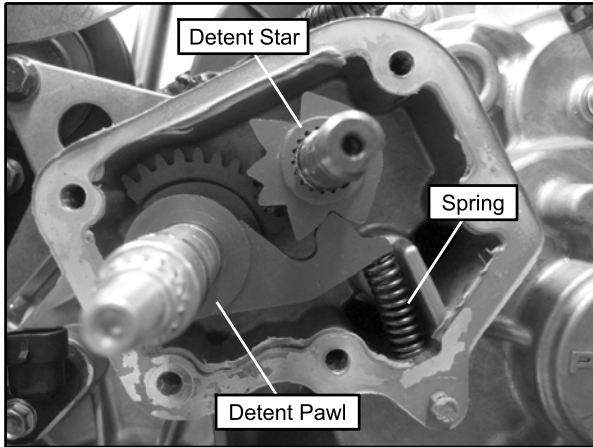

37. Install a new O-ring on each shift shaft. Apply a small amount of white lithium grease on the O-rings, shift shafts and component contact surfaces prior to installing the sector cover.

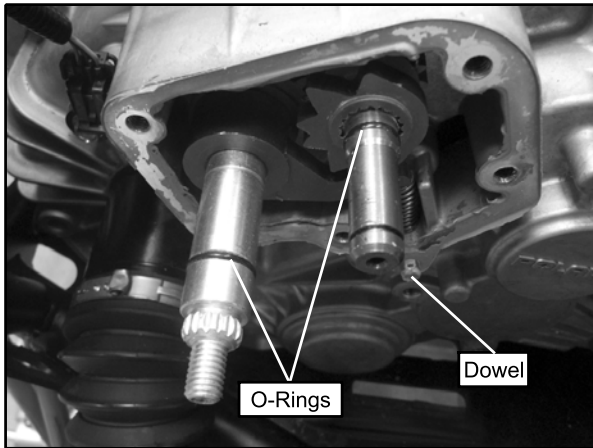

38. Clean the transmission and gear sector cover mating surfaces thoroughly.
39. Apply Crankcase Sealant (3-Bond) (PN 2871557) onto the cover and transmission case mating surface.
40. Install the sector cover and align the transmission case dowel with the alignment hole. Install and torque the bolts to specification.

 = T
<b>Sector Cover Bolts:</b> <b>12 ft-lb (16 Nm)</b>

41. Install the transmission drain plug and torque to specification.

 = T
<b>Fill / Drain Plug:</b> <b>14 ft-lbs (19 Nm)</b>

42. Install the bellcrank onto the shift shaft. Note the key splined on the bellcrank and shift shaft. Install the nut and torque to specification.

 = T
<b>Bell Crank Nut:</b> <b>18 ft-lb (24 Nm)</b>

43. Refer to "Transmission Installation" to complete the repair.

## TROUBLESHOOTING

### Troubleshooting Checklist

Check the following items when shifting difficulty is encountered.

- Shift cable adjustment/condition
- PVT alignment (clutch center distance)
- Idle speed (throttle cable routing)
- Transmission lubricant type/quality
- Loose fasteners on sector gear cover
- Worn rod ends, clevis pins, or pivot arm bushings
- Shift selector rail travel
- Worn, broken or damaged internal transmission components

**NOTE:** To determine if shifting difficulty or problem is caused by an internal transmission problem, isolate the transmission by disconnecting the shift cable end from the transmission bellcrank. Manually select each gear range at the transmission bellcrank, and test ride vehicle. If it functions properly, the problem is outside the transmission.

If transmission problem remains, disassemble transmission and inspect all gear dogs for wear (rounding) or damage. Inspect all bearings, circlips, thrust washers and shafts for wear.

# TRANSMISSION

## TRANSMISSION ASSEMBLY VIEW

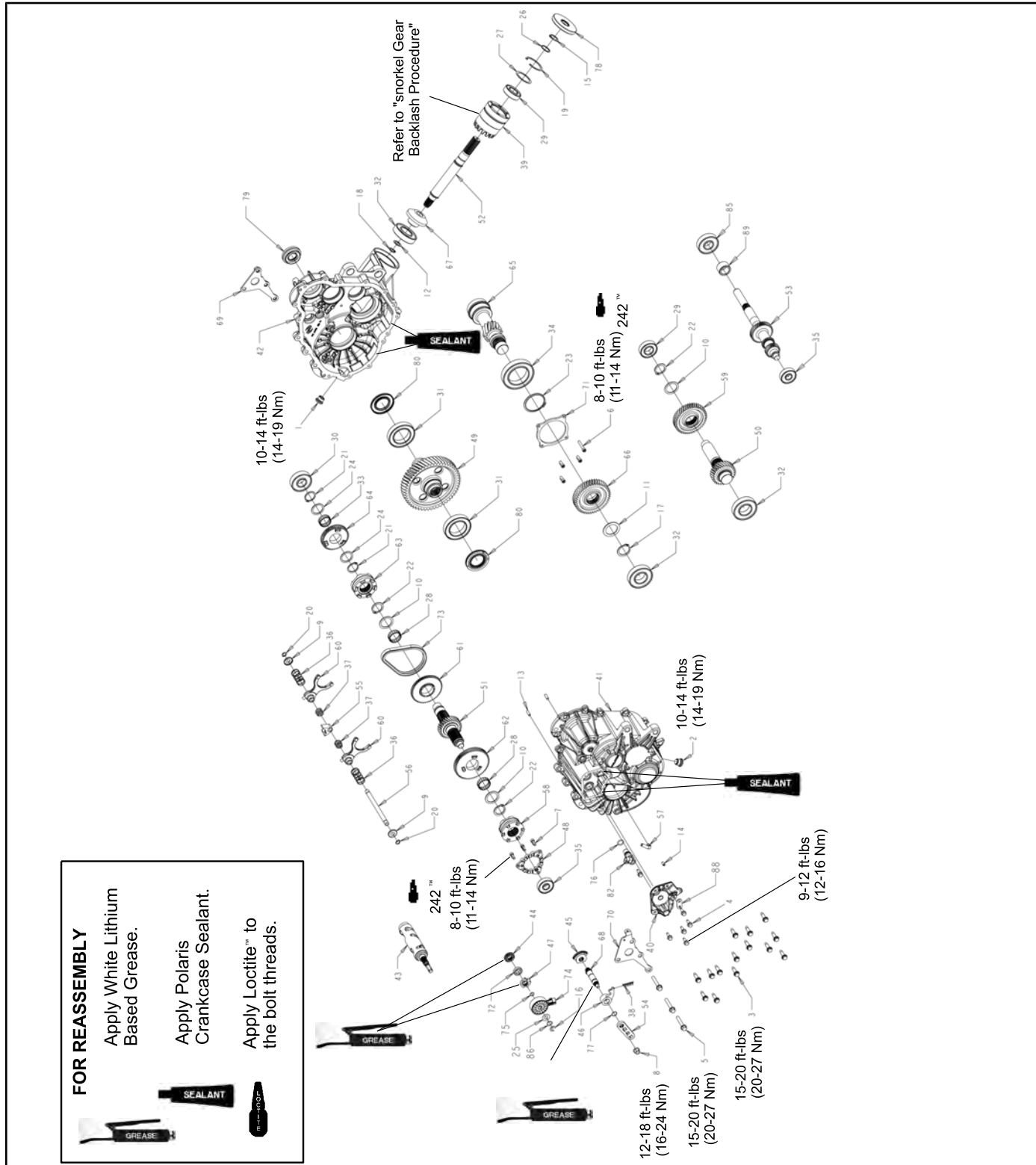

## TRANSMISSION

REF.	QTY.	DESCRIPTION	REF.	QTY.	DESCRIPTION
1.	1	Fill Plug	44.	1	Gear, Sector 16T
2.	1	Drain Plug, Magnetic	45.	1	Gear, Sector 31T
3.	14	Screw, M8 x 1.25 x 30	46.	1	Pawl, Detent
4.	6	Screw, M6 x 1 x 20	47.	1	Star, Detent
5.	3	Screw, M8 x 50	48.	1	Plate, Park, 12-Face
6.	1	Screw, M6 x 1 x 40	49.	1	Shaft, Output 53T
7.	6	Screw, M6 x 1 x 18	50.	1	Shaft, Idler 29T
8.	1	Nut, NyLoc, M8 x 1.25	51.	1	Shaft, Reverse 29T
9.	2	Washer, Cup	52.	1	Shaft, Front Output
10.	3	Washer	53.	1	Shaft, Input Helical
11.	1	Washer	54.	1	Bellcrank
12.	1	Washer	55.	1	Collar, Shift
13.	2	Pin, Dowel	56.	1	Rail, Shift Shaft
14.	1	Pin, Spring	57.	1	Tube, Vent, 1/4 in.
15.	1	Retaining Ring, External	58.	1	Shift Dog, Park
16.	1	Snap Ring	59.	1	Gear, 44T
17.	1	Retaining Ring, External	60.	2	Fork, Shift
18.	1	Retaining Ring, External	61.	1	Sprocket, 48T, 6-Face
19.	1	Retaining Ring, Internal	62.	1	Gear, Low 67T
20.	2	Retaining Ring, External	63.	1	Engagement Dog, 6-Face
21.	2	Retaining Ring, External	64.	1	Gear, 53T
22.	3	Retaining Ring, External	65.	1	Shaft, Pinion 11T
23.	1	Retaining Ring, External	66.	1	Gear, 46T
24.	2	Washer, Thrust	67.	1	Gear, Snorkel 13T
25.	1	Washer, Thrust	68.	1	Shaft, Shift
26.	1	Shim	69.	1	Weldment, Rear Mount Bracket
27.	1	Shim	70.	1	Bracket, Rear Mount
28.	2	Bearing, Needle Cage	71.	1	Cover, Bearing, Center Drive
29.	2	Bearing, Ball	72.	1	Spacer
30.	2	Bearing, Ball	73.	1	Chain, Silent
31.	2	Bearing, Ball	74.	1	Switch, Rotary, 2-Pin
32.	3	Bearing, Ball	75.	1	O-Ring
33.	1	Bearing, Needle Cage	76.	1	O-Ring
34.	1	Bearing, Ball	77.	1	O-Ring
35.	2	Bearing, Ball	78.	1	Seal, Triple Lip
36.	2	Spring, Compression	79.	1	Seal, Dual Lip
37.	2	Spring, Compression	80.	2	Seal, Triple Lip
38.	1	Spring, Compression, Detent	81.	-	N/A
39.	1	Tube, Snorkel	82.	1	Sensor, Speed
40.	1	Cover, Sector Gears	85.	1	Bearing, Ball
41.	1	Case, RH	86.	1	Spring, Wave
42.	1	Case, LH	88.	1	Bracket, Wire Harness
43.	1	Drum, Shift	89.	1	Collar Sleeve, Input Shaft



# TRANSMISSION

## TRANSMISSION ASSEMBLY VIEW (INT'L)

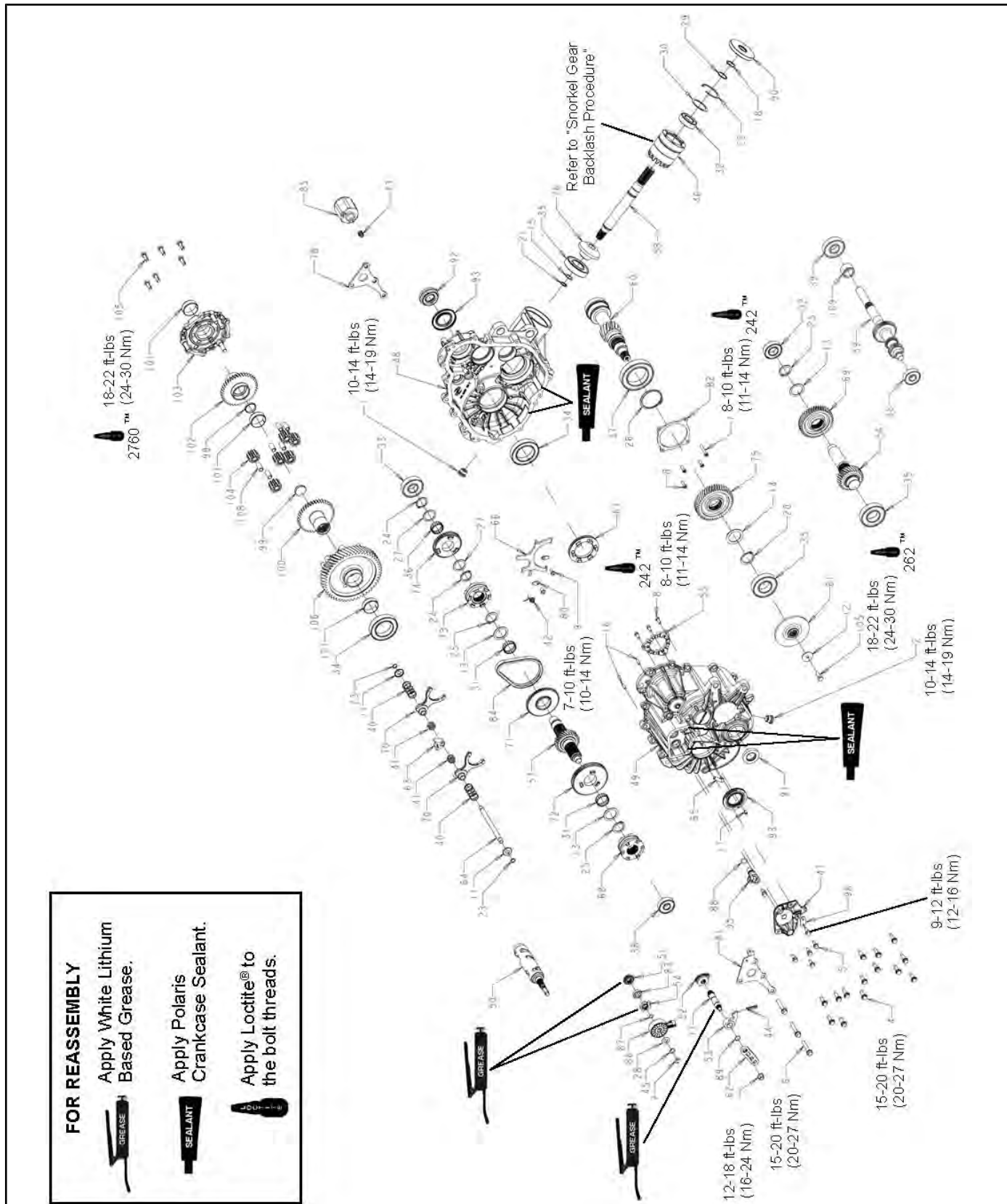

## TRANSMISSION

REF.	DESCRIPTION	REF.	DESCRIPTION	REF.	DESCRIPTION
1.	Fill Plug	37.	Bearing, Ball	72.	Gear, Low 67T
2.	Drain Plug, Magnetic	38.	Bearing, Ball	73.	Engagement Dog, 6-Face
4.	Screw, M8 x 1.25 x 30	39.	Bearing, Ball	74.	Gear, 53T
5.	Screw, M6 x 1 x 20	40.	Spring, Compression	75.	Gear, 46T
6.	Screw, M8 x 50	41.	Spring, Compression	76.	Gear, Snorkel 13T
7.	Screw, M6 x 1 x 40	42.	Spring, Torsion	77.	Shaft, Shift
8.	Screw, M6 x 1 x 18	43.	Spring, Compression	78.	Weldment, Rear Mount Bracket
9.	Screw, M6 x 1 x 16	44.	Spring, Compression, Detent	80.	Retainer, Fork
10.	Nut, NyLoc, M8 x 1.25	45.	Spring, Washer	81.	Bracket, Rear Mount
11.	Washer, Cup	46.	Tube, Snorkel	82.	Cover, Bearing, Center Drive
12.	Washer	47.	Cover, Sector Gears	83.	Spacer
13.	Washer	48.	Case, LH	84.	Chain, Silent
14.	Washer	49.	Case, RH	85.	Solenoid
15.	Washer	50.	Drum, Shift	86.	Switch, Rotary, 2-Pin
16.	Pin, Dowel	51.	Gear, Sector 16T	87.	O-Ring
17.	Pin, Spring	52.	Gear, Sector 31T	88.	O-Ring
18.	Retaining Ring, External	53.	Pawl, Detent	89.	O-Ring
19.	Snap Ring	54.	Star, Detent	90.	Seal, Triple Lip
20.	Retaining Ring, External	55.	Plate, Park, 12-Face	91.	Seal, Triple Lip
21.	Retaining Ring, External	56.	Shaft, Idler 29T	92.	Seal, Dual Lip
22.	Retaining Ring, Internal	57.	Shaft, Reverse 29T	93.	Seal, Triple Lip
23.	Retaining Ring, External	58.	Shaft, Front Output	95.	Sensor, Speed
24.	Retaining Ring, External	59.	Shaft, Input Helical	98.	Bracket, Wire Harness
25.	Retaining Ring, External	60.	Shaft, Pinion, 11T	99.	Plug, Expansion
26.	Retaining Ring, External	61.	Disc, Brake	100.	Side Gear, Male, 39T
27.	Washer, Thrust	62.	Bellcrank	101.	Bearing, Plain
28.	Washer, Thrust	63.	Collar, Shift	102.	Side Gear, Female, 39T
29.	Shim	64.	Rail, Shift Shaft	103.	Diff Cover
30.	Shim	65.	Tube, Vent, 1/4 in.	104.	Planet Gear
31.	Bearing, Needle Cage	66.	Fork, Pivot Shaft	105.	Screw, M8 x 1.25 x 25
32.	Bearing, Ball	67.	Dog, Engagement	106.	Ring Gear, 53T
33.	Bearing, Ball	68.	Shift Dog, Park	108.	Bearing, Plain
34.	Bearing, Ball	69.	Gear, 44T	109.	Collar Sleeve, Input Shaft
35.	Bearing, Ball	70.	Fork, Shift		
36.	Bearing, Needle Cage	71.	Sprocket, 48T, 6-Face		



# CHAPTER 9

## BRAKES

GENERAL INFORMATION .....	9.3
SPECIAL TOOLS .....	9.3
GENERAL SPECIFICATIONS .....	9.3
TORQUE SPECIFICATIONS .....	9.3
BRAKE SYSTEM SERVICE NOTES .....	9.3
BRAKE NOISE TROUBLESHOOTING .....	9.4
HYDRAULIC BRAKE SYSTEM OPERATION .....	9.4
BRAKE SYSTEM .....	9.7
ASSEMBLY VIEW .....	9.7
MASTER CYLINDER .....	9.8
REMOVAL .....	9.8
INSTALLATION .....	9.8
BRAKE PEDAL LEVER .....	9.9
PEDAL REMOVAL .....	9.9
PEDAL INSTALLATION .....	9.9
BRAKE BLEEDING / FLUID CHANGE .....	9.9
PARKING BRAKE (INT'L MODEL) .....	9.11
ASSEMBLY VIEW .....	9.11
PARKING BRAKE INSPECTION .....	9.12
PARKING BRAKE CABLE ADJUSTMENT .....	9.12
PARKING BRAKE CALIPER SERVICE (INT'L MODEL) .....	9.13
CALIPER ASSEMBLY VIEW .....	9.13
CALIPER REMOVAL .....	9.14
CALIPER DISASSEMBLY / INSPECTION .....	9.14
NEW BRAKE PAD INSTALLATION .....	9.15
CALIPER INSTALLATION .....	9.16
PARKING BRAKE DISC (INT'L MODEL) .....	9.16
DISC INSPECTION .....	9.16
DISC REPLACEMENT .....	9.17
FRONT BRAKE PADS .....	9.17
PAD REMOVAL .....	9.17
PAD INSPECTION .....	9.18
PAD ASSEMBLY / INSTALLATION .....	9.19
BRAKE BURNISHING PROCEDURE .....	9.19
FRONT CALIPER SERVICE .....	9.20
CALIPER ASSEMBLY VIEW .....	9.20
CALIPER REMOVAL .....	9.20
CALIPER DISASSEMBLY .....	9.21
CALIPER INSPECTION .....	9.22
CALIPER ASSEMBLY .....	9.23
CALIPER INSTALLATION .....	9.23
FRONT BRAKE DISC .....	9.24

# BRAKES

---

DISC RUNOUT .....	9.24
DISC INSPECTION .....	9.25
DISC REPLACEMENT .....	9.25
REAR BRAKE PADS .....	9.26
PAD REMOVAL .....	9.26
PAD INSPECTION .....	9.27
PAD ASSEMBLY / INSTALLATION .....	9.28
BRAKE BURNISHING PROCEDURE .....	9.29
REAR CALIPER SERVICE .....	9.30
CALIPER ASSEMBLY VIEW .....	9.30
CALIPER REMOVAL .....	9.30
CALIPER DISASSEMBLY .....	9.31
CALIPER INSPECTION .....	9.32
CALIPER ASSEMBLY .....	9.32
CALIPER INSTALLATION .....	9.33
REAR BRAKE DISC .....	9.34
DISC INSPECTION .....	9.34
DISC REPLACEMENT .....	9.34
TROUBLESHOOTING .....	9.35
BRAKES SQUEAL / POOR BRAKE PERFORMANCE .....	9.35
PEDAL VIBRATION .....	9.35
CALIPER OVERHEATS (BRAKES DRAG) .....	9.35
BRAKES LOCK .....	9.35

## GENERAL INFORMATION

### SPECIAL TOOLS

PART NUMBER	TOOL DESCRIPTION
2870975	

PART NUMBER	TOOL DESCRIPTION
	Mity Vac™ Pressure Test Tool

**Bosch Automotive Service Solutions:** 1-800-345-2233  
or <http://polaris.service-solutions.com/>

### GENERAL SPECIFICATIONS

FRONT BRAKE SYSTEM		
Item	Standard	Service Limit
Front Brake Pad Thickness	0.297 ± .007" (7.54 ± .178 mm)	.180" (4.6 mm)
Front Brake Disc Thickness	0.188" (4.78 mm)	.170" (4.32 mm)
Front Brake Disc Runout	-	.010" (.254 mm)

REAR BRAKE SYSTEM		
Item	Standard	Service Limit
Rear Brake Pad Thickness	.298 ± .007" (7.57 ± .178 mm)	.180" (4.6 mm)
Rear Brake Disc Thickness	.188" (4.78 mm)	.170" (4.32 mm)
Rear Brake Disc Runout	-	.010" (.254 mm)

PARK BRAKE SYSTEM (INT'L MODEL)		
Item	Standard	Service Limit
Park Brake Pad Thickness	Inboard - 0.300" (7.62 mm)	0.240" (6.10 mm)
	Outboard - 0.250" (6.35 mm)	0.190" (4.83 mm)
Park Brake Disc Thickness	0.175" - 0.185" (4.44 - 4.70 mm)	0.150" (3.81 mm)

### TORQUE SPECIFICATIONS

ITEM	TORQUE
Caliper Mounting Bolts	<b>40 ft-lbs (54 Nm)</b>
Brake Line Flare	<b>15 ft-lbs (20 Nm)</b>
Brake Line Banjo Bolts	<b>15 ft-lbs (20 Nm)</b>
Brake Switch	<b>15 ft-lbs (20 Nm)</b>
Brake Bleeder Screw	<b>48 in-lb (5 Nm)</b>
Brake Disc to Hub Bolts	<b>30 ft-lb (41 Nm)</b>
Master Cylinder Mounting Bolts	<b>23 ft-lbs (31 Nm)</b>
Brake Pedal Mounting Bracket to Frame	<b>16 ft-lbs (22 Nm)</b>
Park Brake Disc Mounting Bolt	<b>14 ft-lb (20 Nm)</b>
Park Brake Lever Mount Bolts	<b>16 ft-lb (22 Nm)</b>
Park Brake Caliper Assembly Bolts	<b>37 ft-lb (50 Nm)</b>

### BRAKE SYSTEM SERVICE NOTES

Disc brake systems are light weight, low maintenance, and perform well in the conditions this vehicle will routinely encounter. There are a few things to remember when replacing disc brake pads or performing brake system service to ensure proper system function and maximum pad service life.

- DO NOT over-fill the master cylinder fluid reservoir.
- Make sure the brake pedal returns freely and completely.
- Adjust stop pin on brake caliper (s) after pad service.
- Check and adjust master cylinder reservoir fluid level after pad service.
- Make sure atmospheric vent on reservoir is unobstructed.
- Test for brake drag after any brake system service and investigate cause if brake drag is evident.
- Make sure caliper moves freely on guide pins (where applicable).
- Inspect caliper piston seals for foreign material that could prevent caliper pistons from returning freely.

# BRAKES

- Perform a brake burnishing procedure after installing new pads to maximize service life.
- DO NOT lubricate or clean the brake components with aerosol or petroleum products. Use only approved brake cleaning products.

## BRAKE NOISE TROUBLESHOOTING

Dirt or dust buildup on the brake pads and disc is the most common cause of brake noise (squeal caused by vibration). If cleaning does not reduce the occurrence of brake noise, Permatex™ *Disc Brake Quiet* can be applied to the back of the pads. Follow directions on the package. This will keep pads in contact with caliper piston(s) to reduce the chance of squeaks caused by dirt or dust.

### Brake Noise Troubleshooting

POSSIBLE CAUSE	REMEDY
Dirt, dust, or imbedded material on pads or disc	Spray disc and pads with CRC Brakleen™ or an equivalent non-flammable aerosol brake cleaner. Remove pads and/or disc hub to clean imbedded material from disc or pads.
<b>Pad(s) dragging on disc due to:</b> Improper adjustment Master cylinder reservoir overfilled Master cylinder compensating port restricted Master cylinder piston not returning completely Caliper piston(s) not returning Operator error (riding the brake)	Adjust pad stop (front calipers) Set to proper level Clean compensating port Inspect. Repair as necessary Clean piston(s) seal Educate operator
Loose wheel hub or bearings	Check wheel and hub for abnormal movement.
Brake disc warped or excessively worn	Replace disc
Brake disc misaligned or loose	Inspect and repair as necessary
Noise is from other source (axle, hub, disc or wheel)	If noise does not change when brake is applied check other sources. Inspect and repair as necessary

## HYDRAULIC BRAKE SYSTEM OPERATION

The Polaris brake system consists of the following components or assemblies: brake pedal, master cylinder, hydraulic brake lines, brake calipers, brake pads, and brake discs, which are secured to the drive line.

When the foot activated brake lever is applied it applies pressure on the piston within the master cylinder. As the master cylinder piston moves inward it closes a small opening (compensating port) within the cylinder and starts to build pressure within the brake system. As the pressure within the system is increased, the pistons located in the brake calipers move outward and apply pressure to the moveable brake pads. These pads contact the brake discs and move the calipers in their floating bracket, pulling the stationary side pads into the brake discs. The resulting friction reduces brake disc and vehicle speed.

The friction applied to the brake pads will cause the pads to wear. As these pads wear, the piston within the caliper moves further outward and becomes self adjusting. Fluid from the reservoir fills the additional area created when the caliper piston moves outward.

Brake fluid level is critical to proper system operation. Too little fluid will allow air to enter the system and cause the brakes to feel spongy. Too much fluid could cause brakes to drag due to fluid expansion.

Located within the master cylinder is the compensating port which is opened and closed by the master cylinder piston assembly. As the temperature within the hydraulic system changes, this port compensates for fluid expansion or contraction. Due to the high temperatures created within the system during heavy braking, it is very important that the master cylinder reservoir have adequate space to allow for fluid expansion. **Never overfill the reservoir! Do not fill the reservoir beyond the MAX LEVEL line!**

When servicing Polaris brake systems use only **Polaris DOT 4 Brake Fluid (PN 2872189)**.

## 9.4

**WARNING:** Once a bottle is opened, use what is necessary and discard the rest in accordance with local laws. Do not store or use a partial bottle of brake fluid. Brake fluid is hygroscopic, meaning it rapidly absorbs moisture. This causes the boiling temperature of the brake fluid to drop, which can lead to early brake fade and the possibility of serious injury.



# BRAKES

---

## 9.6

---

## BRAKE SYSTEM

### Assembly View

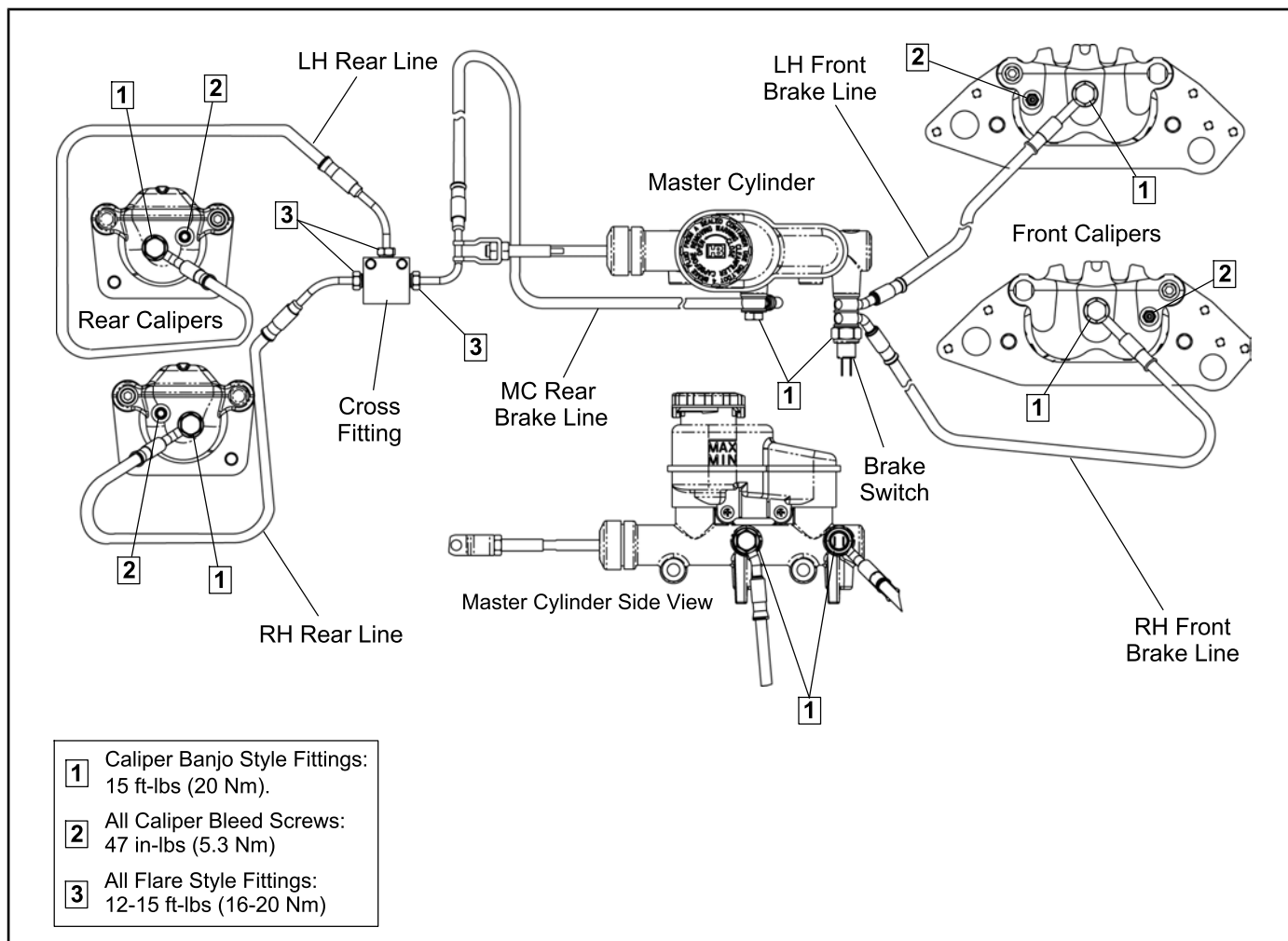

# BRAKES

## MASTER CYLINDER

### Removal

1. Locate the master cylinder (Item 1) above the left front tire in the wheel well area.

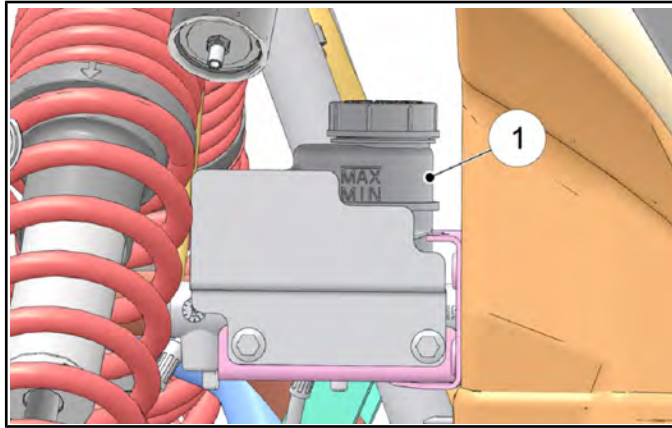

2. Remove the clip (Item 2) from the clevis pin (Item 3) that attaches the master cylinder to the brake pedal lever.

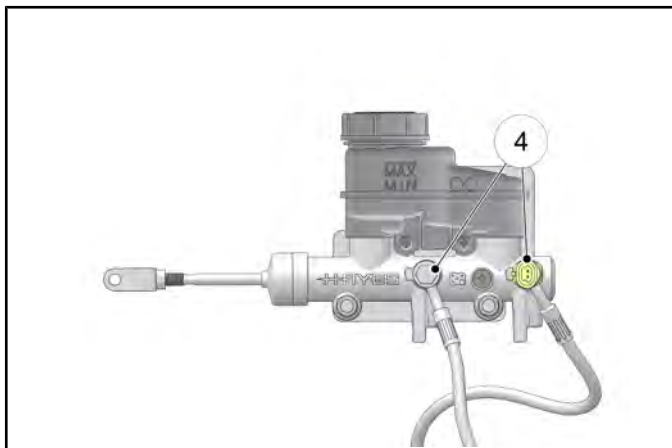
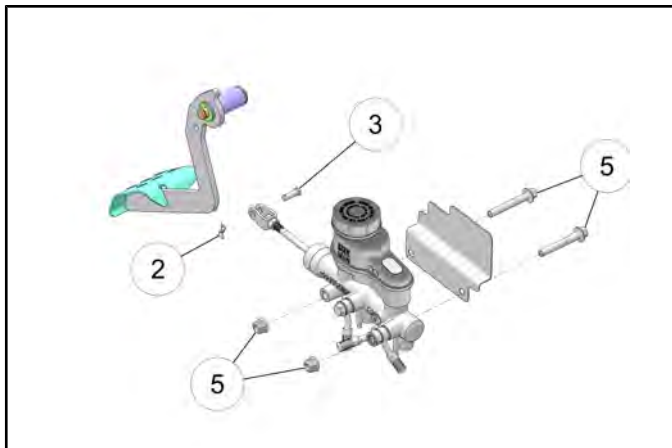

3. Place a container to catch brake fluid under the master cylinder brake line banjo bolts (Item 4).

### CAUTION

Brake fluid will damage finished surfaces.  
Do not allow brake fluid to come in contact  
with finished surfaces.

**NOTE:** Make note of front and rear brake line locations to master cylinder.

4. Loosen the brake line banjo bolts (Item 4) and allow fluid to drain.

**NOTE:** Dispose of fluid properly. Do not re-use.

5. Remove the two mounting fasteners (Item 5) that secure the master cylinder to the frame.

### Installation

1. Reverse Steps 1-5 for master cylinder installation.



Banjo Bolts  
**15 ft-lbs (20 Nm)**

Master Cylinder Mounting Fasteners  
**23 ft-lbs (31 Nm)**

2. After installing the foot brake check pedal free-play. Pedal free-play should not exceed .090" (2.286 mm).

## BRAKE PEDAL LEVER

### Pedal Removal

1. Locate the brake pedal lever (Item 2) and remove the clip (Item 1) and master cylinder clevis pin (Item 4).
2. Remove the E-clip (Item 3) from the pedal mount and remove the brake pedal lever (Item 2) from the vehicle.

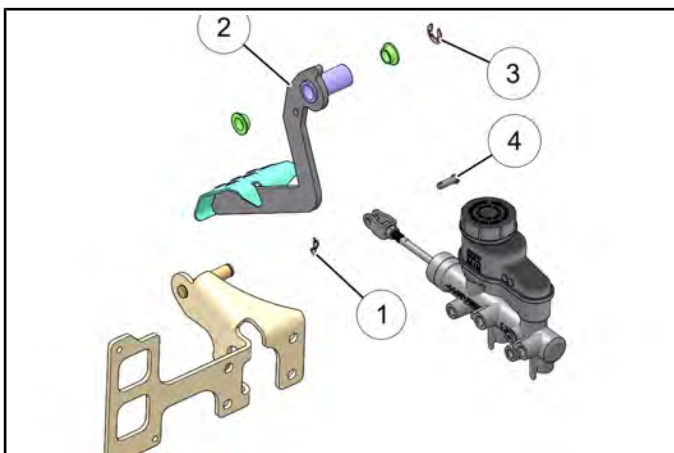

### Pedal Installation

1. Reverse the "Removal" steps to install brake pedal lever. Brake pedal free-play should not exceed 0.090" (2.28 mm).

**Brake Pedal Free-play:  
0.090" (2.28 mm)**

## BRAKE BLEEDING / FLUID CHANGE

**NOTE:** When bleeding the brakes or replacing the fluid always start with the furthest caliper from the master cylinder. This procedure should be used to change fluid or bleed brakes during regular maintenance.

### CAUTION

Always wear safety glasses.

### CAUTION

Brake fluid will damage finished surfaces. Do not allow brake fluid to come in contact with finished surfaces.

1. Clean master cylinder reservoir cover thoroughly and remove the cover (Item 2).

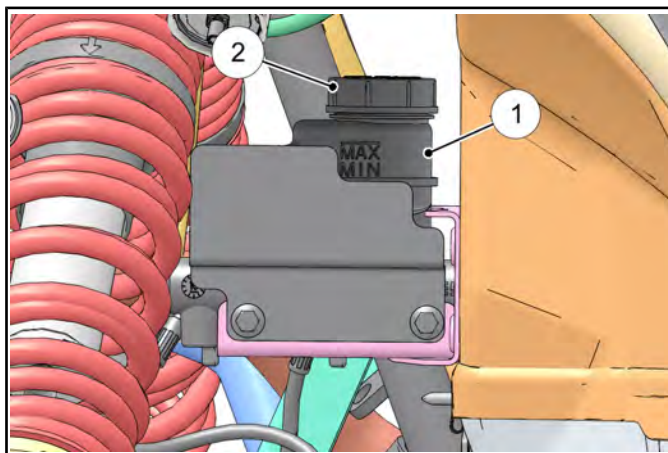

2. If changing fluid, remove old fluid from reservoir (Item 1) with a Mity Vac™ pump or similar tool.

**Mity Vac™: PN 2870975**

3. Add brake fluid to the indicated MAX level of reservoir.

**Polaris DOT 4 Brake Fluid  
(PN 2872189)**

4. Begin bleeding procedure with the caliper that is farthest from the master cylinder. Install a box end wrench on caliper bleeder screw. Attach a clean, clear hose to fitting and place the other end in a clean container. Be sure the hose fits tightly on fitting.

## BRAKES

5. Have an assistant slowly pump foot pedal until pressure builds and holds.
6. Hold brake pedal down to maintain pedal pressure, and open bleeder screw (Item 3). Close bleeder screw and release pedal.
12. Field test machine at low speed before putting into service. Check for proper braking action and pedal reserve. With pedal firmly applied, pedal reserve should be no less than 1/2"(1.3 cm).
13. Check brake system for fluid leaks.

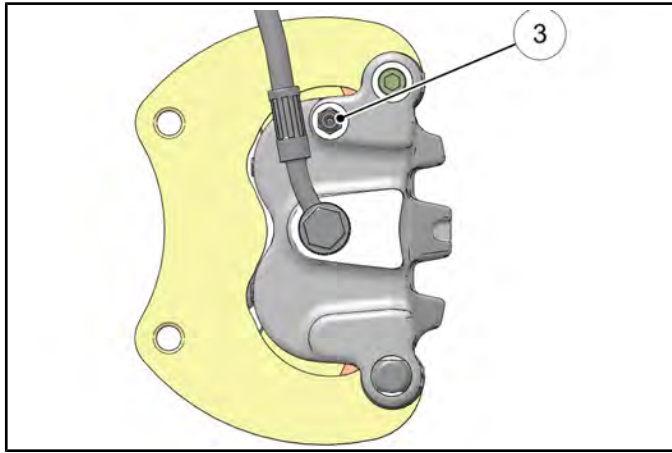

**NOTE:** Do not release foot pedal before bleeder screw is tight or air may be drawn into master cylinder.

7. Repeat procedure until clean fluid appears in bleeder hose and all air has been purged. Add fluid as necessary to maintain level in reservoir.

### CAUTION

Maintain at least 1/2"(1.27 cm) of brake fluid in the reservoir to prevent air from entering the master cylinder.

8. Tighten bleeder screw securely and remove bleeder hose. Torque bleeder screw to specification.



Bleeder Screw:  
**48 in-lb (5 Nm)**

9. Repeat steps 5 - 8 for the remaining calipers.
10. Add brake fluid to MAX level inside reservoir.

### Master Cylinder Fluid Level

**Between MIN and MAX lines on reservoir.**

11. Install master cylinder reservoir cover.

**PARKING BRAKE (INT'L MODEL)**

**Assembly View**

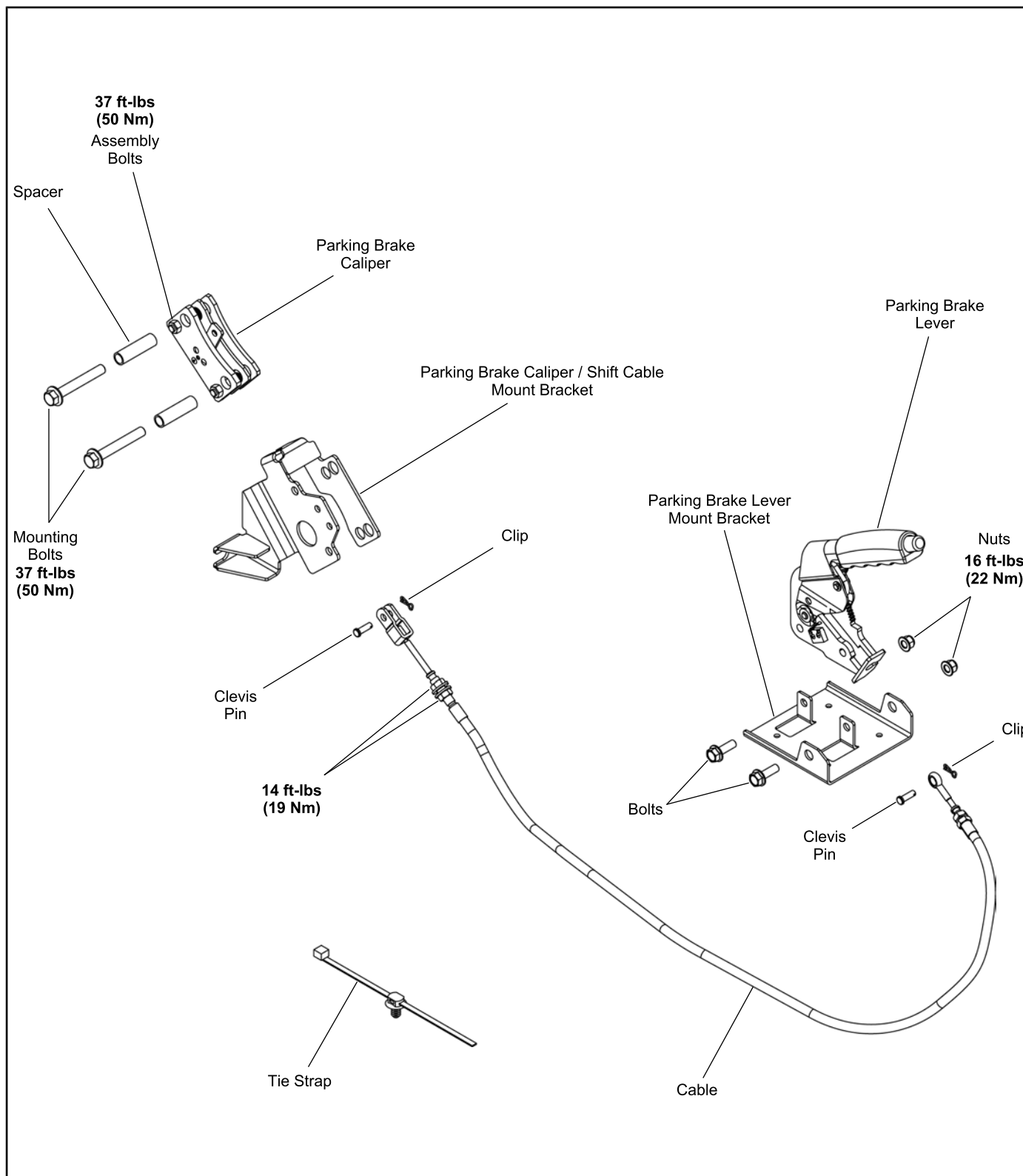

# BRAKES

## Parking Brake Inspection

1. Inspect parking brake cable and brake pads for wear.
2. Refer to "Parking Brake Cable Adjustment" if adjustment is necessary. Refer to "Parking Brake Caliper Service" for brake pad replacement.

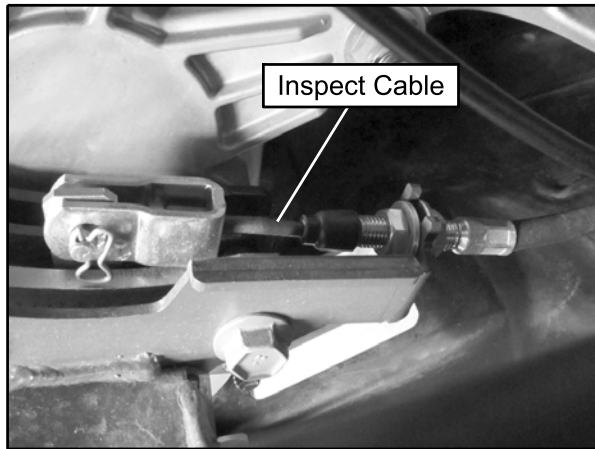

## Adjustment Procedure

5. Place the vehicle in neutral on a flat level surface.
6. Locate the parking brake cable adjustment area where the cable attaches to the caliper mount bracket.

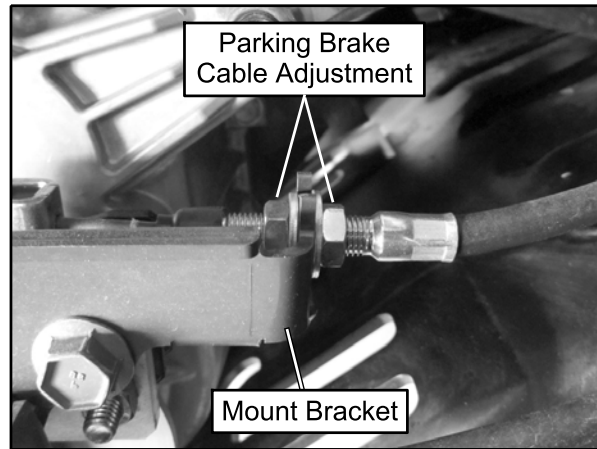

## Parking Brake Cable Adjustment

When the parking brake is fully engaged and "BRAKE" is displayed on the instrument cluster, engine speed is limited to 1500 RPM while in gear. If throttle is applied, this limiting feature prevents operation, which protects the parking brake pads from excessive wear.

**NOTE: Inspect parking brake cable tension after the first 25 hours of operation and every 100 hours of operation afterwards to ensure proper cable tension.**

Loss of tension in the parking brake cable will cause illumination of the parking brake indicator and activation of the limiting feature. If this occurs, inspect and adjust parking brake cable tension. If performing this service is difficult due to conditions or location, temporarily disconnect the parking brake switch electrical connector. Reconnect the connector as soon as practicable and adjust the parking brake cable to proper tension.

1. Pull back on parking brake lever (located in the dash).
2. After 3 to 4 clicks "BRAKE" should display on the instrument cluster and the wheels should not rotate when turning by hand. After 8 full clicks of lever travel, the vehicle should not roll while parked.
3. If the vehicle moves, adjustment is necessary.
4. Adjust the parking brake cable where it attaches to the caliper mount / shift cable bracket. The mount bracket is located on the right-hand side of the transmission.

7. Use two open-end wrenches and loosen the outer jam nut (D). Back out the outer jam nut (D) 1 1/2 turns.

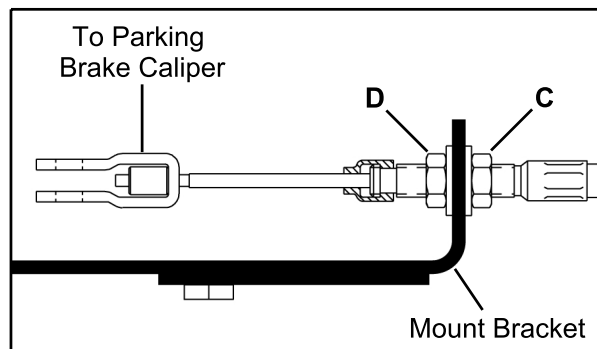

8. Now hold the outer jam nut (D) and turn in the inner jam nut (C) clockwise, until the jam nut is tight against the bracket.
9. Repeat Step 3 and Step 4 until the proper adjustment is obtained for the parking brake.

**NOTE: See Chapter 10- Parking Brake Switch (INT'L Model), page 10.17 for more information on the parking brake switch.**

**PARKING BRAKE CALIPER SERVICE**  
**(INT'L MODEL)**

**Caliper Assembly View**

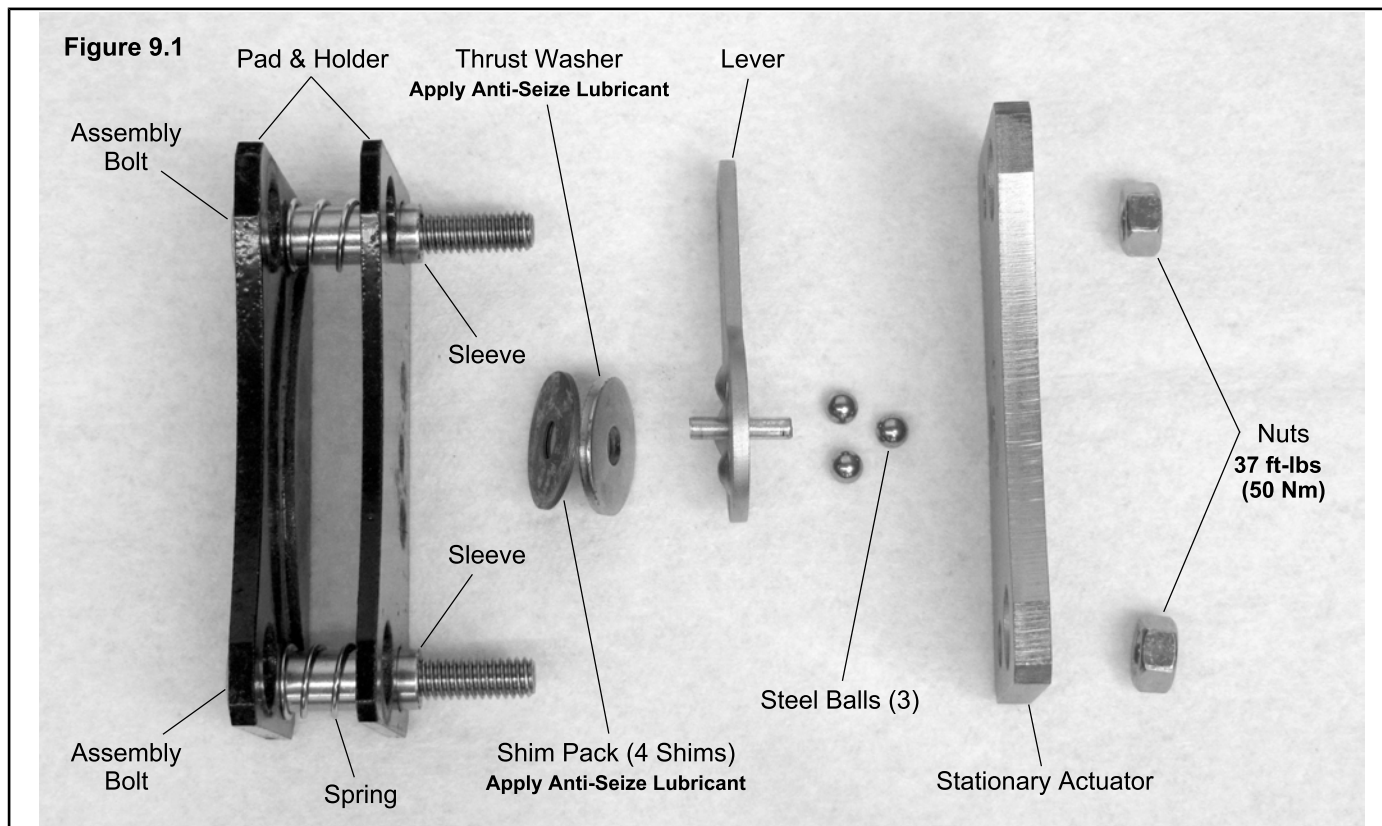



# BRAKES

## Caliper Removal

**NOTE:** Do not get oil, grease, or fluid on the parking brake pads. Damage to or contamination of the pads may cause the pads to function improperly.

1. Remove the clip pin and pin (A) from the parking brake cable.

**NOTE:** Be sure the parking brake is not engaged.

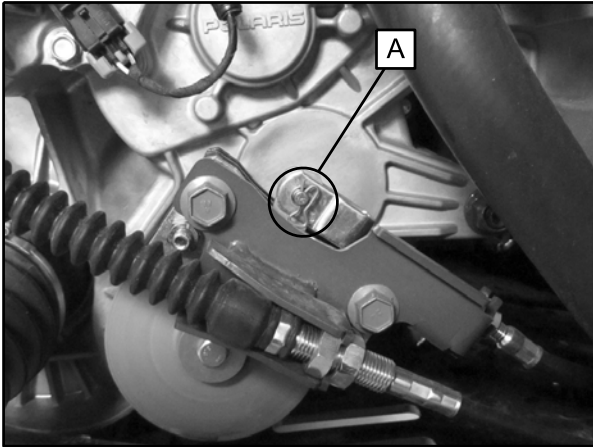

2. Remove the two fasteners (B) retaining the parking brake caliper mount / shift cable bracket.

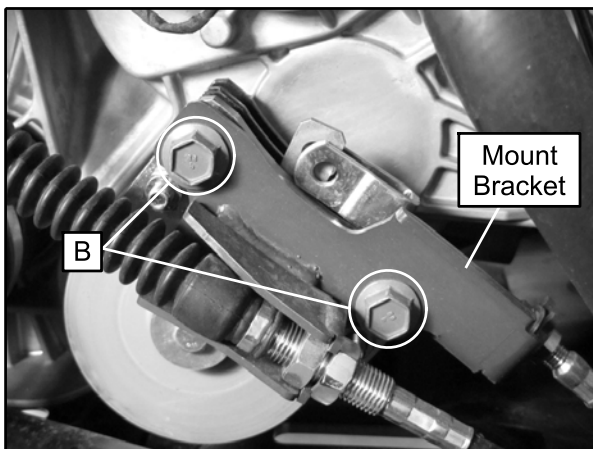

3. Lift the parking brake caliper off the brake disc and remove it from the vehicle.

## Caliper Disassembly / Inspection

**NOTE:** Refer to the “Electronic Parts Catalog” for parking brake caliper replacement parts information.

1. Remove the two caliper assembly bolts (C).

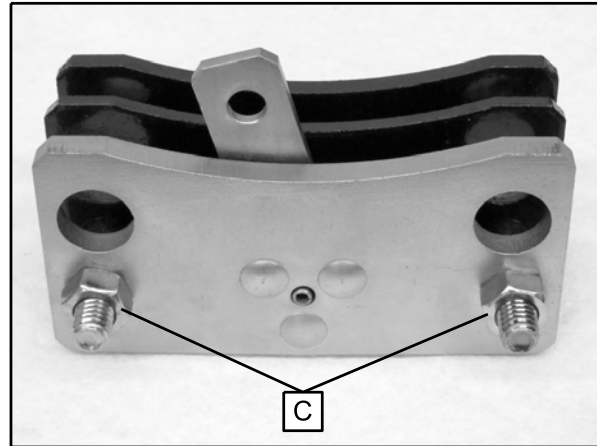

2. Slide the brake pads and springs from the assembly.

**NOTE:** Retain the lever and ball bearings for reassembly.

3. Inspect brake pads for excessive wear. Replace as needed.
4. Check the three steel balls for any signs of cracking. Replace as needed.
5. Check ball seats in lever and stationary actuator. If excessively worn, replace parts as needed.

6. Measure thickness of the rear caliper parking brake pads. Replace assembly or pads as needed. Refer to the following image for brake pad specifications.

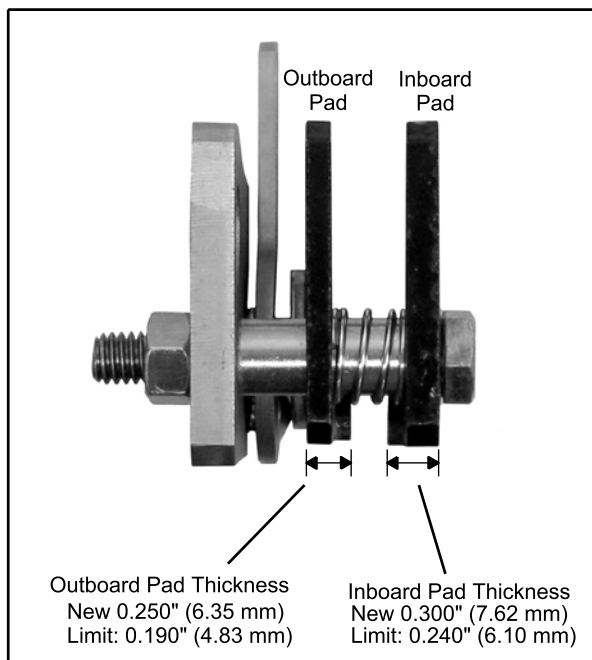

4. Torque the caliper assembly bolts to specification.

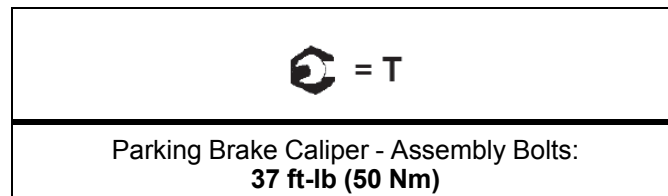

5. Ensure the parking brake assembly functions properly by actuating the lever. Install the mounting sleeves (D) before installation.

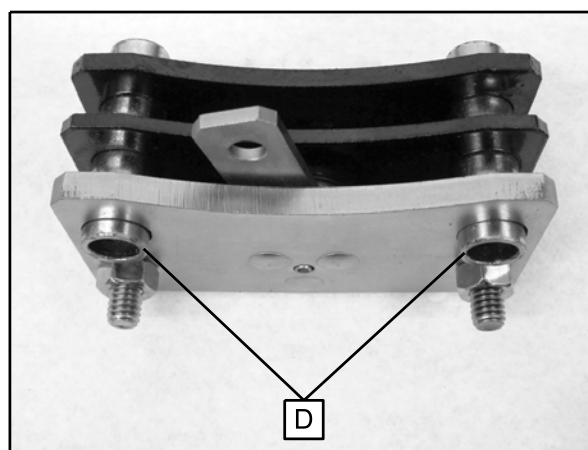

## New Brake Pad Installation

1. Install new pads and assemble the caliper with one shim. For shim location, see **Figure 9.1** on page 9.11.
2. Measure gap for the brake disc and compare to gap specification. Disassemble and add shim(s) between thrust washer and the inside brake pad as needed to close the gap to .207-.217 in. (5.25-5.51 mm).

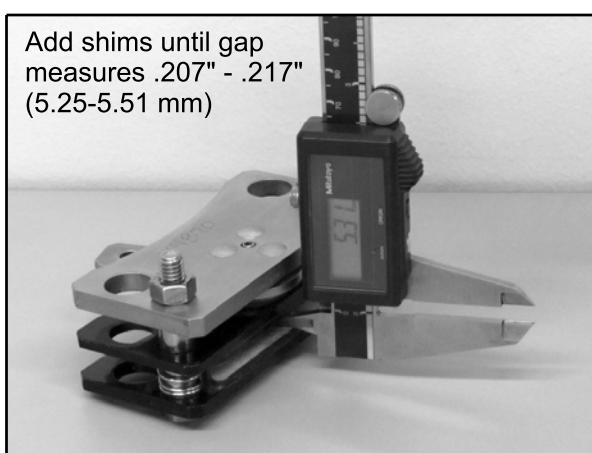



3. Once you have determined the correct amount of shims to use, reassemble the caliper and apply an Anti-Seize Lubricant to the thrust washer and shims.

# BRAKES

## Caliper Installation

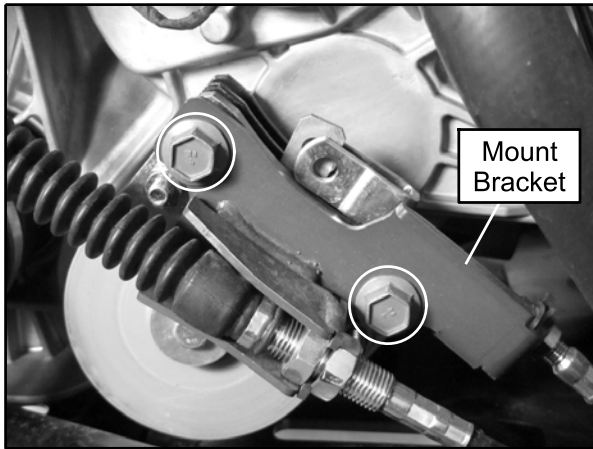
1. Install the parking brake caliper over the brake disc. Align the caliper mounting sleeves with the holes in the mount bracket.
2. Install and tighten the two caliper mount / shift cable bracket fasteners to specification.



 = T

Parking Brake Caliper - Mount Bracket Bolts:  
**37 ft-lb (50 Nm)**

3. Install the cable, pin and clip pin. Test the park brake for proper function.

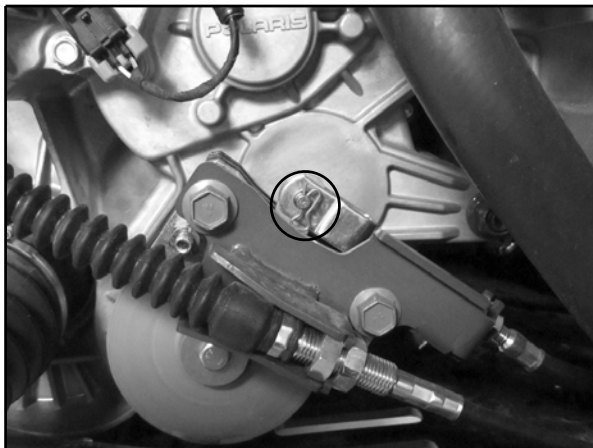

## PARKING BRAKE DISC (INT'L MODEL)

### Disc Inspection

1. Measure the brake disc with a micrometer. If the thickness of the disc is less than specified, replace the brake disc (see "Disc Replacement").

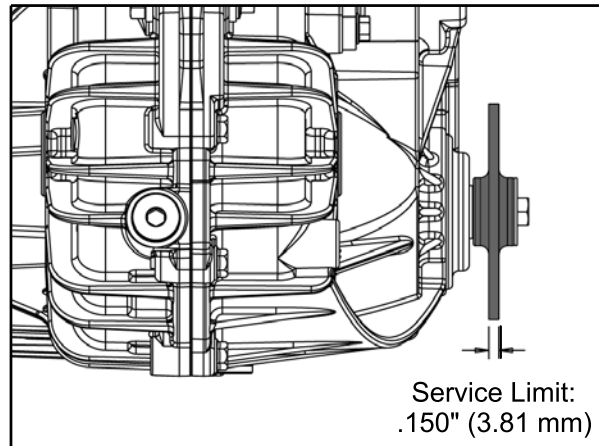

## Disc Replacement

1. Remove the parking brake caliper from the disc (see "Caliper Removal").
2. Using a 1/2" socket and ratchet, remove the brake disc retaining bolt and flat washer.
3. Remove the disc from the transmission shaft.
4. Install the new brake disc. Install the mounting bolt and flat washer. Torque the mounting bolt to specification.

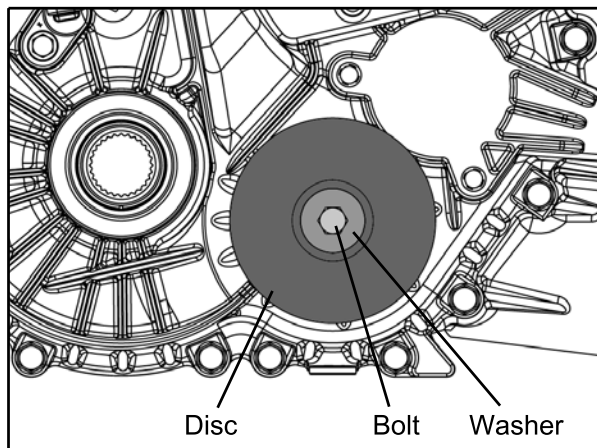

Parking Brake Disc Mounting Bolt:  
14 ft-lb (20 Nm)

## FRONT BRAKE PADS

### Pad Removal

1. Elevate and support front of vehicle.

#### CAUTION

Use care when supporting vehicle so that it does not tip or fall.  
Severe injury may occur if machine tips or falls.

2. Remove the wheel nuts and front wheel.
3. Loosen the pad adjuster screw 2-3 turns.

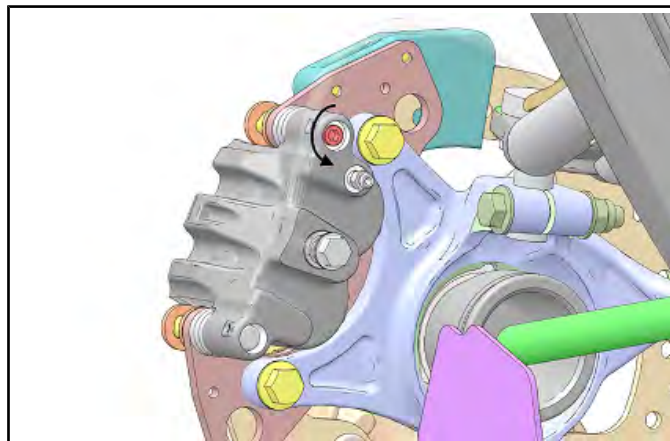

4. Remove the upper and lower caliper mounting bolts and remove the caliper from the front hub.

**NOTE:** When removing caliper, use care not to damage brake line. Support caliper to avoid kinking or bending brake line.

## BRAKES

5. Push caliper piston into caliper bore slowly using a C-clamp or locking pliers with pads installed.

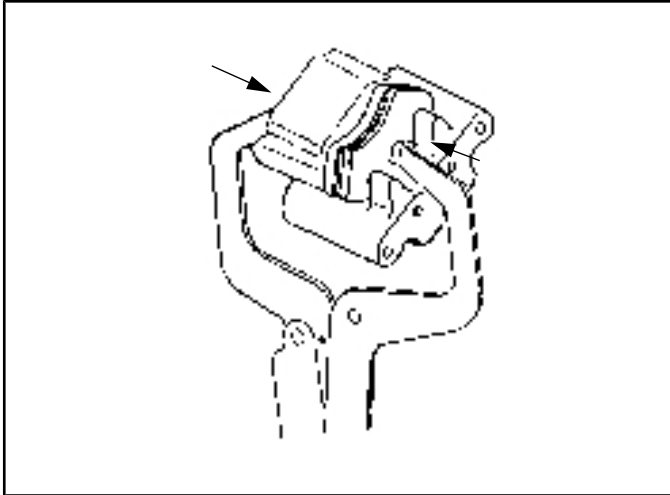

**NOTE:** Brake fluid will be forced through compensating port into master cylinder fluid reservoir when piston is pushed back into caliper. Remove excess fluid from reservoir as required.

6. Push the mounting bracket inward and slip the outer brake pad out between the bracket and caliper body.



7. Remove the inner pad from the bracket and caliper.

### Pad Inspection

1. Measure the thickness of the pad material. Replace pads if worn beyond the service limit.

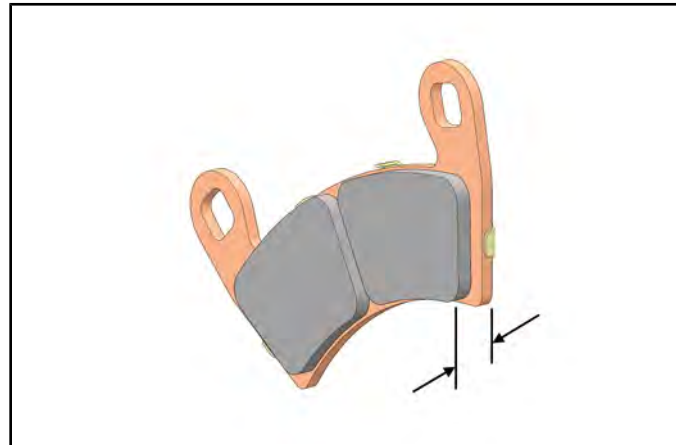
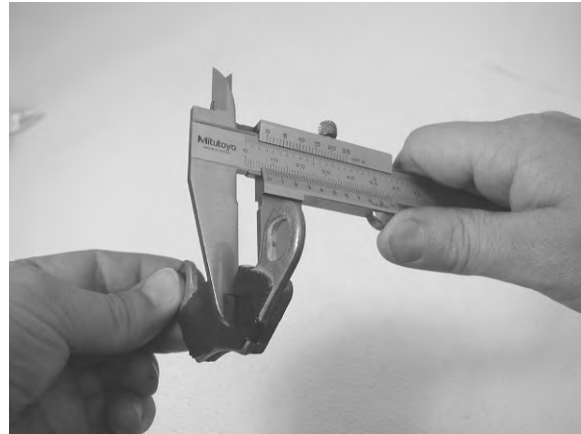

**Front Brake Pad Thickness:**  
**0.297 ± 0.007" (7.5 ± .178 mm)**  
**Service Limit: 0.180" (4.6 mm)**

## Pad Assembly / Installation

1. Lubricate mounting bracket pins (Item 1) with a light film of silicone grease and install rubber dust boots.

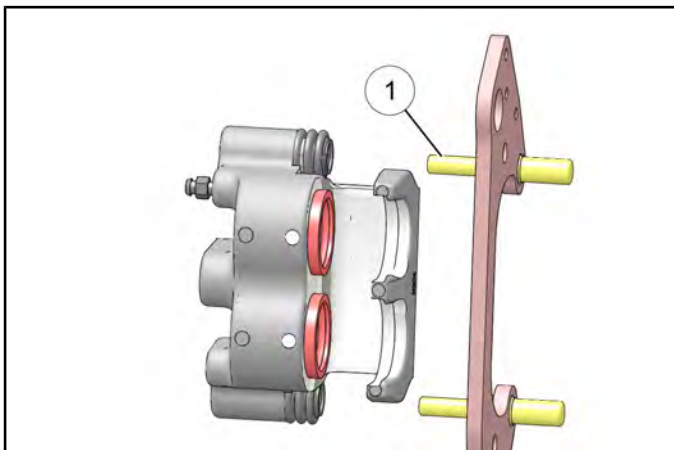

2. Compress mounting bracket and make sure dust boots are fully seated. Install pads with friction material facing each other.

### WARNING

If brake pads are contaminated with grease, oil, or liquid soaked do not use the pads.  
Use only new, clean pads.

3. Install caliper onto front hub and torque mounting bolts (Item 2) to specification.

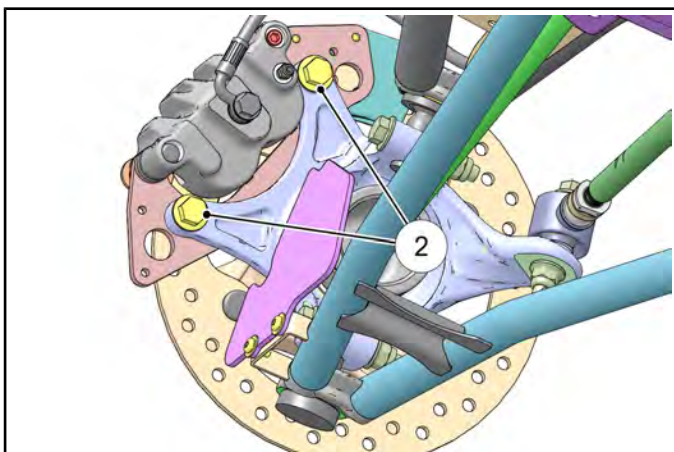

 = T

Front Caliper Mount Bolt:  
40 ft-lbs (54 Nm)

4. Slowly pump the brake pedal until pressure has been built up. Maintain at least 1/2" (12.7 mm) of brake fluid in the reservoir to prevent air from entering the brake system.
5. Install the adjustment set screw and turn clockwise until stationary pad contacts disc, then back off 1/2 turn (counterclockwise).

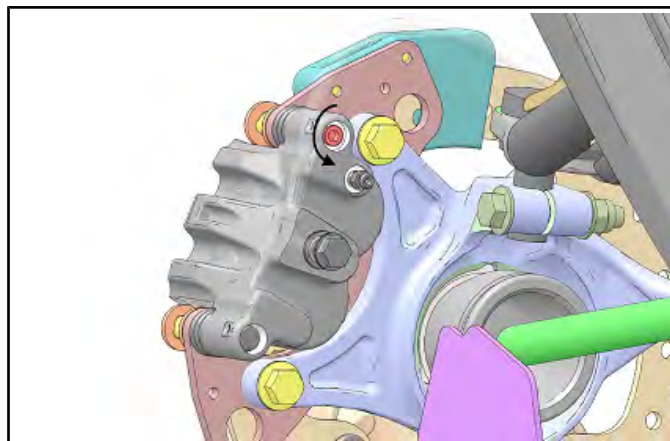

6. Verify fluid level in reservoir is up to MAX line inside reservoir and install reservoir cap.

### Master Cylinder Fluid

Up to MAX line inside reservoir

7. Install wheel and torque wheel nuts to specification.

 = T

Wheel Nuts:  
120 ft-lbs (163 Nm)

## Brake Burnishing Procedure

It is required that a burnishing procedure be performed after installation of new brake pads to extend service life and reduce noise.

Start machine and slowly increase speed to 30 mph. Gradually apply brakes to stop machine. Allow pads and disc to cool sufficiently during the procedure. Do not allow pads or disc to become hot or warping may result. Repeat this procedure 10 times. **Do not make more than 3 stops per 1 mile (1.6 km).**

# BRAKES

## FRONT CALIPER SERVICE

### Caliper Assembly View

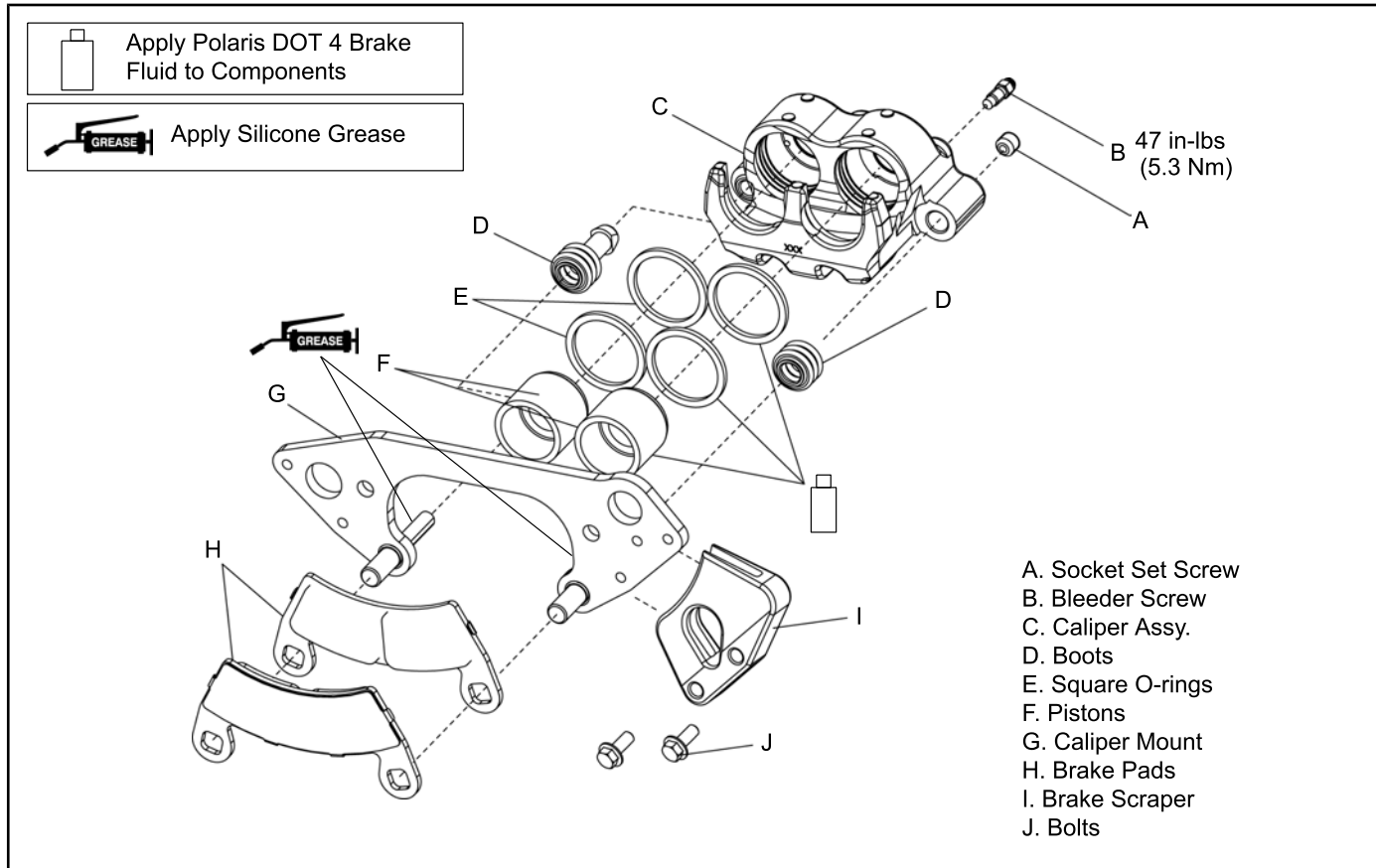

### Caliper Removal

1. Elevate and safely support the front of the vehicle.
2. Remove the four wheel nuts and the front wheel.

#### CAUTION

Use care when supporting vehicle so that it does not tip or fall. Severe injury may occur.

3. Clean caliper area before removal.

4. Place a container below the caliper to catch brake fluid when removing the line (Item 1). Remove brake line from caliper.

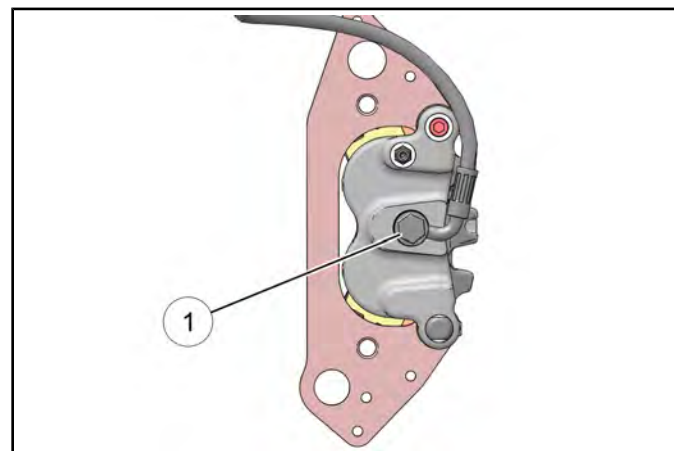

- Loosen brake pad adjustment set screw 2-3 turns to allow brake pad removal after the caliper is removed.

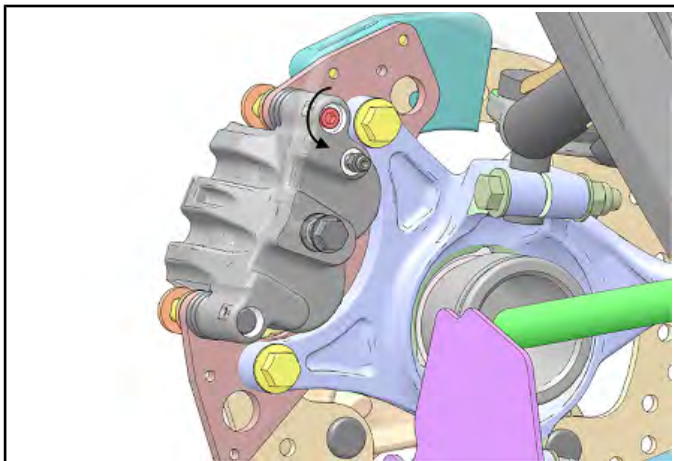

- Remove the two caliper mounting bolts (Item 2) and remove the caliper assembly from the front hub.

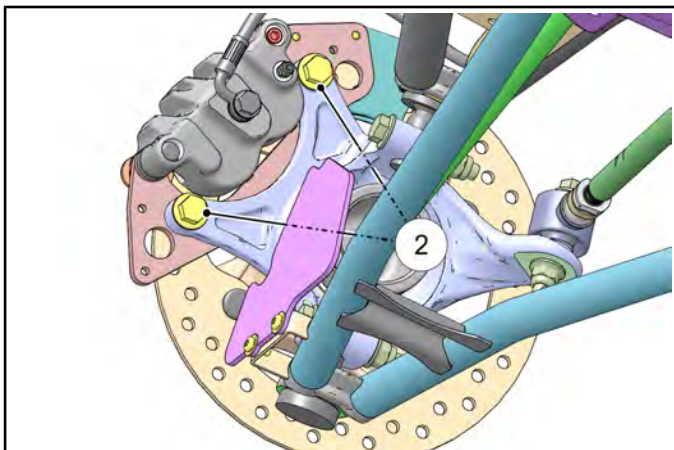

## Caliper Disassembly

- Remove both brake pads from the caliper (see "FRONT BRAKE PADS - Pad Removal").
- Remove mount bracket assembly (Item 1) and dust boots (Item 2).

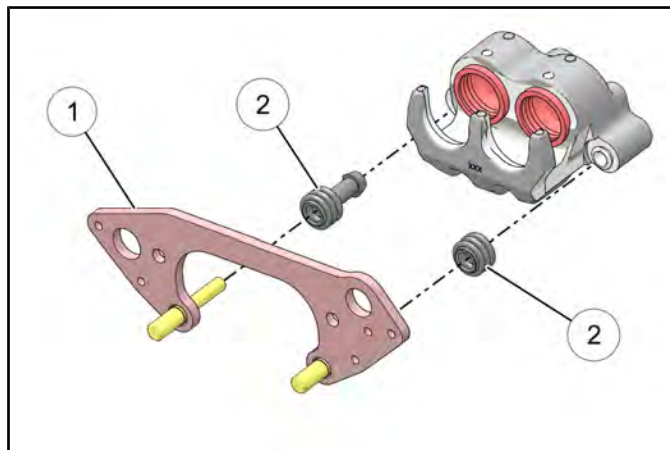

- Thoroughly clean the caliper before disassembly and prepare a clean work area for disassembly.
- Use a commercially available caliper piston pliers to extract the pistons from the caliper.

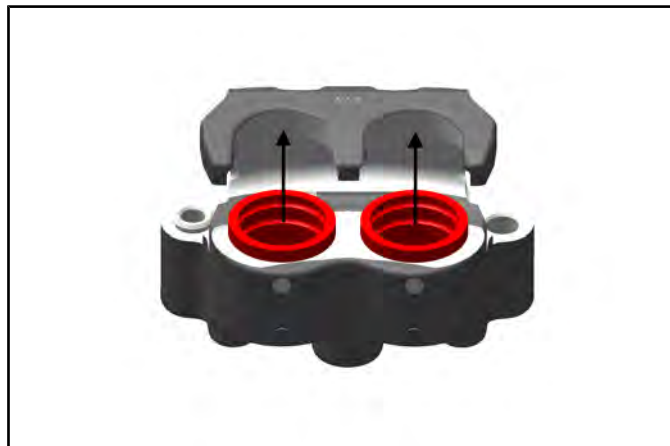

**NOTE:** Do not remove the caliper pistons with a standard pliers. The piston sealing surfaces will become damaged if a standard pliers is used.



# BRAKES

- Once the pistons are removed, use a pick to carefully remove the square O-rings from the caliper. O-rings should be replaced during caliper service.

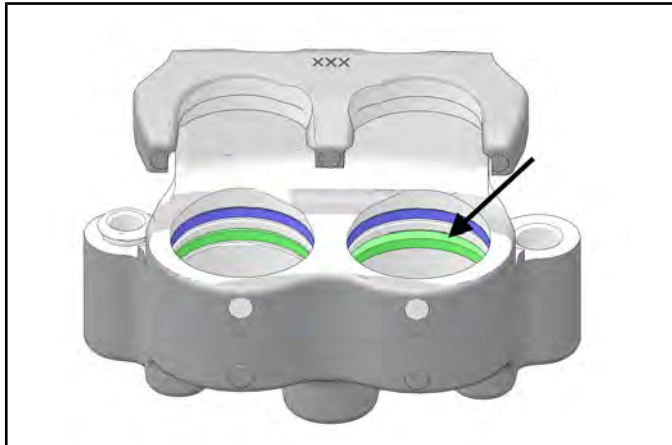

- Clean the caliper body, pistons and retaining bracket (Item 3) with brake cleaner or alcohol.

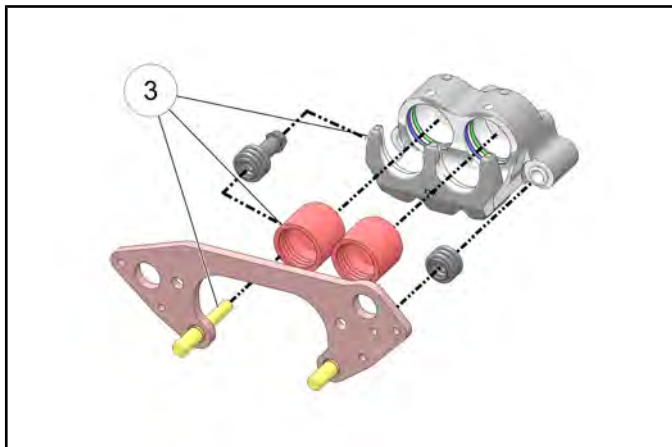

**NOTE:** Be sure to clean seal grooves in caliper body.

## Caliper Inspection

- Inspect caliper body for nicks, scratches, pitting or wear. Measure bore size and compare to specifications. Replace if damaged or worn beyond service limit.

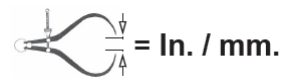

Front Caliper Piston Bore I.D.:  
**Std: 1.373" (34.87 mm)**  
**Service Limit: 1.375" (34.93 mm)**

- Inspect piston for nicks, scratches, pitting or wear. Measure piston diameter and replace if damaged or worn beyond service limit.

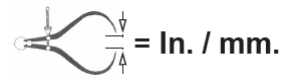
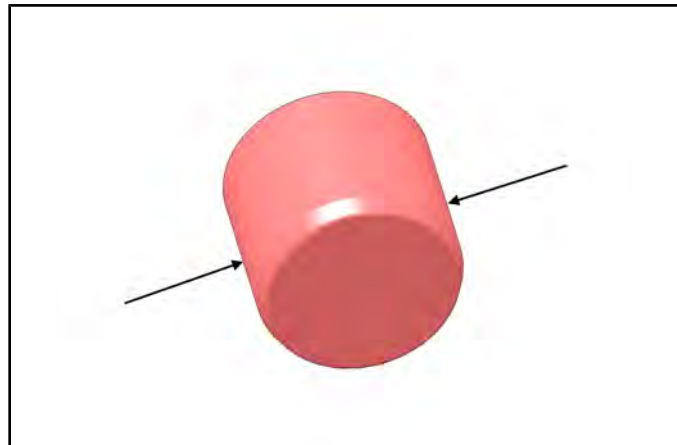

Front Caliper Piston O.D.:  
**Std: 1.370" (34.80 mm)**  
**Service Limit: 1.368" (34.75 mm)**

3. Inspect the brake disc and pads as outlined in this chapter.

## Caliper Assembly

1. Install new O-rings (Item 2) in the caliper body. Be sure the grooves (Item 1) are clean and free of residue or brakes may drag upon assembly.

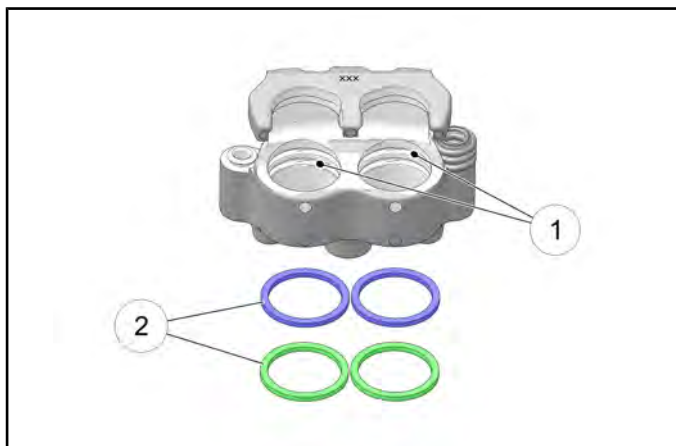

2. Coat pistons with clean Polaris DOT 4 Brake Fluid. Install pistons with a twisting motion while pushing inward. Piston should slide in and out of bore smoothly, with light resistance.
3. Lubricate the mounting bracket pins (Item 3) with silicone grease and install the rubber dust seal boots.

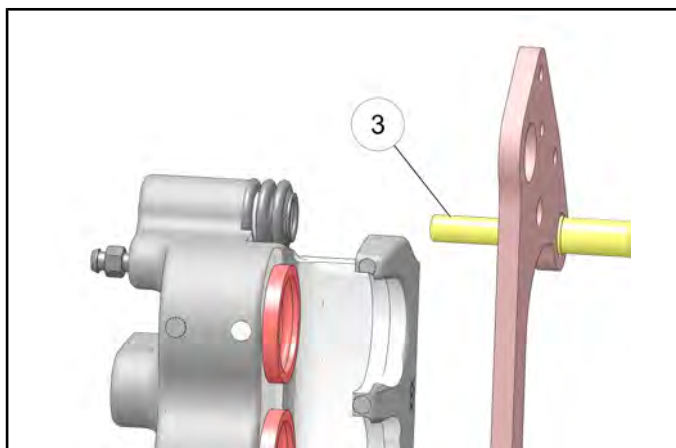

4. Compress the mounting bracket and make sure the dust seal boots are fully seated. Install the brake pads. Clean the disc and pads with brake parts cleaner or denatured alcohol to remove any dirt, oil or grease.

## Caliper Installation

1. Install the brake line onto the caliper taking care not to allow any debris to enter the caliper.
2. Install the caliper and torque the mounting bolts to specification.

**NOTE: If disc scraper (Item 1) was removed, reinstall it upon caliper installation.**

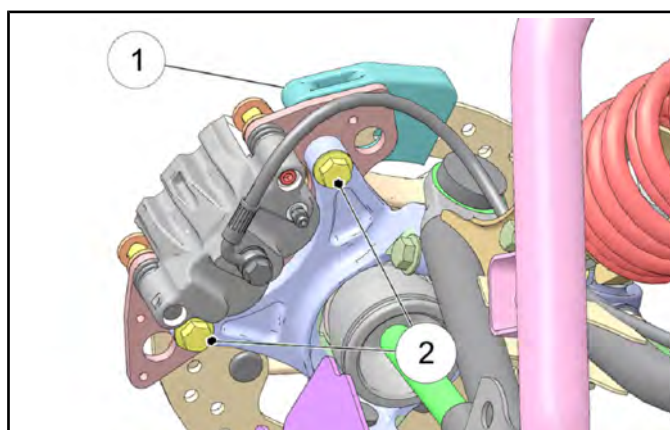

Front Caliper Mount Bolt (Item 2):  
40 ft-lbs (54 Nm)

3. Torque the banjo bolt (Item 3) to specification.

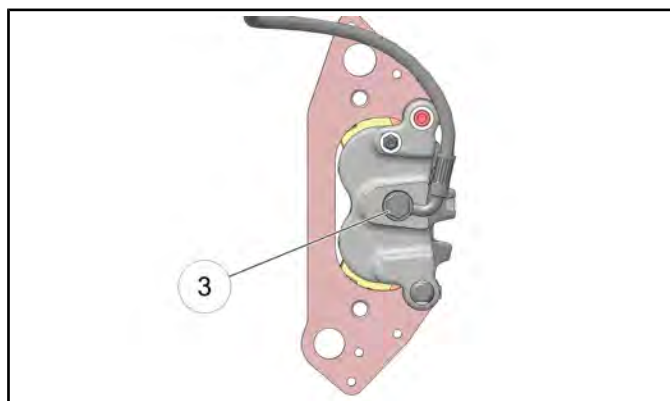

Banjo Bolt  
15 ft-lbs (20 Nm)

# BRAKES

4. Install the adjustment set screw and turn clockwise until stationary pad contacts disc, then back off 1/2 turn (counterclockwise).

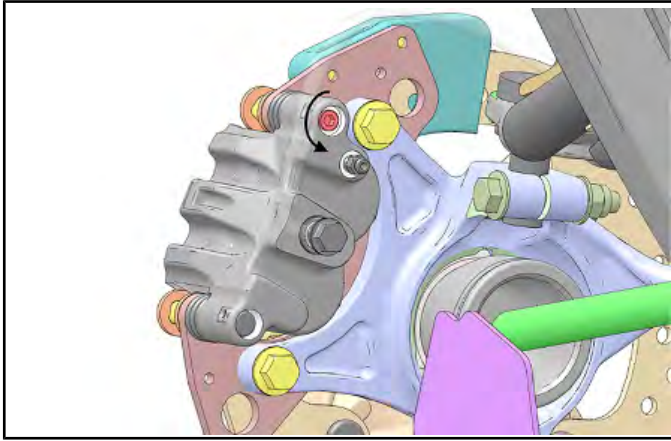

5. Perform brake bleeding procedure as outlined earlier in this chapter.
6. Install wheel and torque wheel nuts to specification.



Wheel Nuts:  
**120 ft-lbs (163 Nm)**

7. Field test unit for proper braking action before putting into service. Inspect for fluid leaks and firm brakes. Make sure the brake is not dragging when pedal is released. If the brake drags, re-check assembly and installation.

**NOTE: If new pads are installed, refer to Brake Burnishing Procedure, page 9.19.**

## FRONT BRAKE DISC

### Disc Runout

1. Mount dial indicator as shown to measure disc runout. Slowly rotate the disc and read total runout on the dial indicator. Replace the disc if runout exceeds specification.

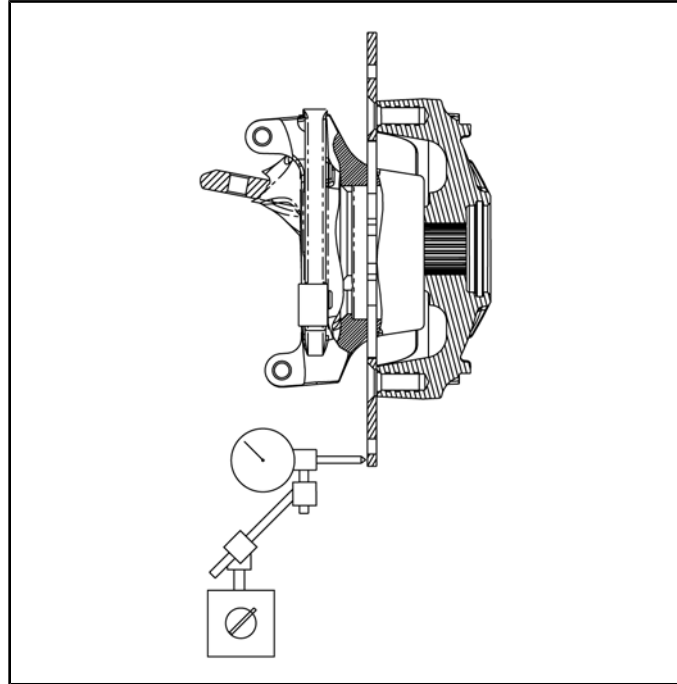

**Brake Disc Runout:  
Service Limit: 0.010" (0.254 mm)**

## Disc Inspection

1. Visually inspect disc for scoring, scratches, or gouges. Replace disc if deep scratches are evident.
2. Use a 0-1" micrometer and measure disc thickness at eight different points around the pad contact surface. Replace disc if worn beyond service limit.

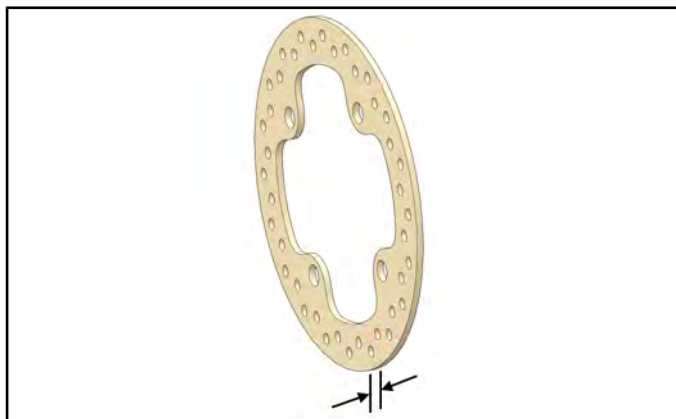

**Brake Disc Thickness**  
**New: .0188" (4.78 mm)**  
**Service Limit: 0.170" (4.32 mm)**

**Brake Disc Thickness Variance**  
**Service Limit: 0.002" (.051 mm)**  
**difference between measurements**

## Disc Replacement

1. Remove the front brake caliper (see "FRONT CALIPER SERVICE").
2. Remove wheel hub cotter pin (Item 4), castle nut (Item 3) and washers (Item 2).
3. Remove the wheel hub assembly from the vehicle and remove the (4) bolts (Item 1) retaining the disc to the hub.

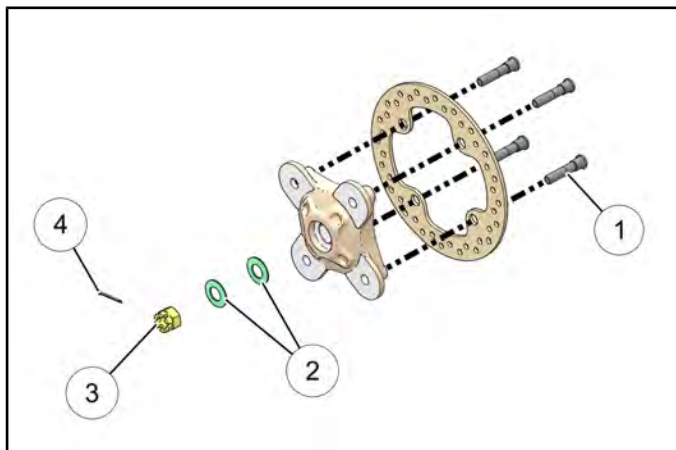

4. Clean the wheel hub mating surface and install new disc on wheel hub.
5. Install new bolts (Item 5) and torque to specification.

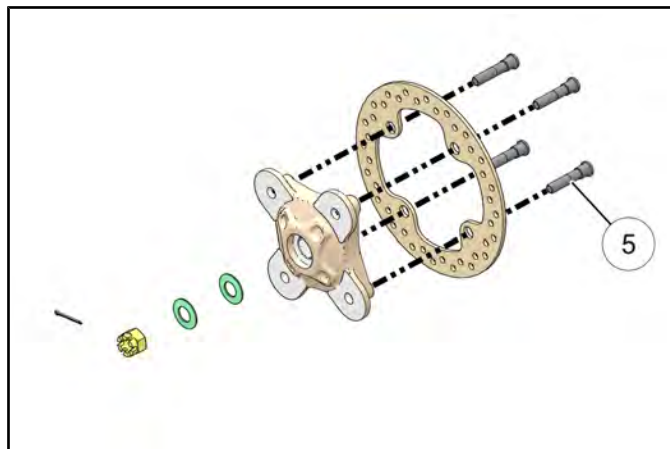

**Brake Disc Mounting Bolts (Item 5):**  
**30 ft-lb (41 Nm)**

### CAUTION

Always use new brake disc mounting bolts. The bolts have a pre-applied locking agent which is destroyed upon removal.

6. Install wheel hub assembly, washers, and castle nut. Torque castle nut to specification and install a new cotter pin.



**Castle Nut:**  
**110 ft-lbs (149 Nm)**

7. Install the front brake caliper (see FRONT CALIPER SERVICE, page 9.20).
8. Follow bleeding procedure outlined earlier in this chapter.
9. Field test unit for proper braking action before putting into service. Inspect for fluid leaks and firm brakes. Make sure the brake is not dragging when pedal is released. If the brake drags, re-check assembly and installation.

# BRAKES

## REAR BRAKE PADS

### Pad Removal

1. Elevate and support rear of vehicle.

#### CAUTION

Use care when supporting vehicle so that it does not tip or fall.  
Severe injury may occur if machine tips or falls.

2. Remove the rear wheel.
3. Loosen pad adjuster screw 2-3 turns.

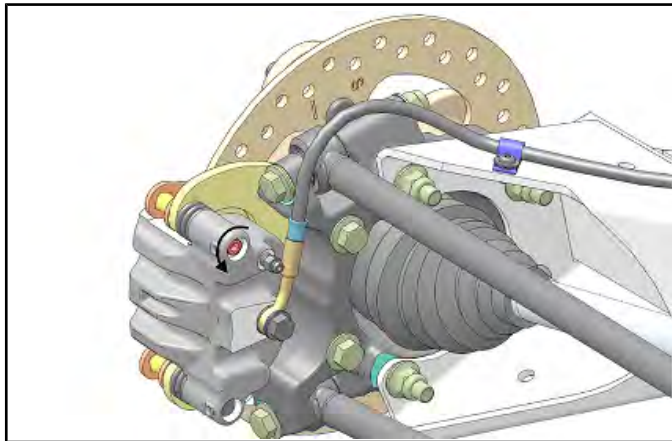

4. Remove the lower radius rod outer mounting bolt, nut and washer from the bearing carrier. Swing radius rod down. Discard the nut.

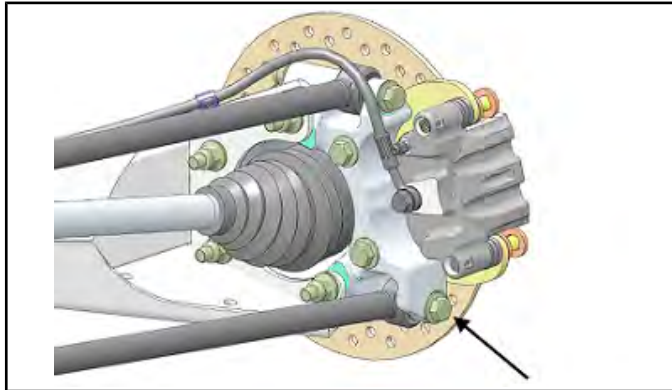

5. Remove the two caliper mounting bolts and lift caliper off the brake disc.

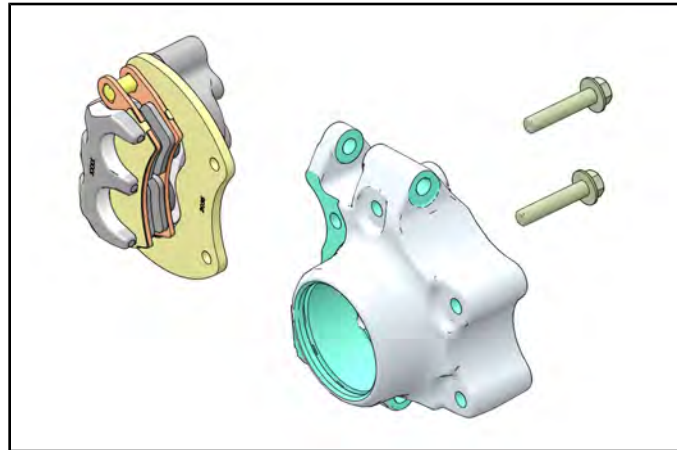

**NOTE:** When removing caliper, be careful not to damage brake line. Support caliper to avoid kinking or bending brake line.

6. Push caliper piston into the caliper bore slowly using a C-clamp or locking pliers with pads installed.

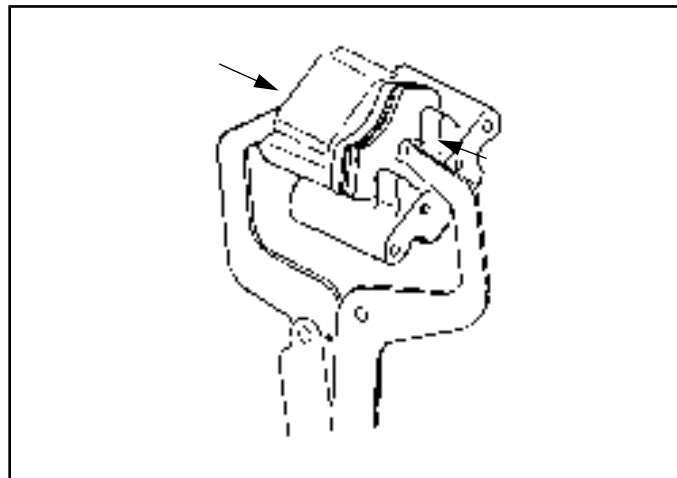

**NOTE:** Brake fluid will be forced through compensating port into master cylinder fluid reservoir when piston is pushed back into caliper. Remove excess fluid from reservoir as required.

7. Push caliper mounting bracket inward and slip outer brake pad past the edge to remove.

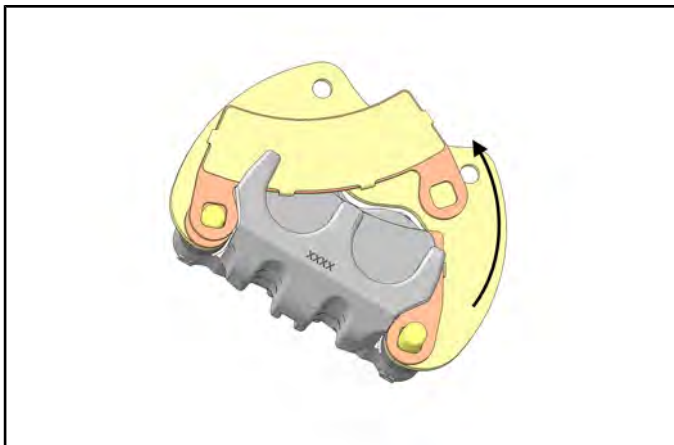

8. Remove the inner brake pad.

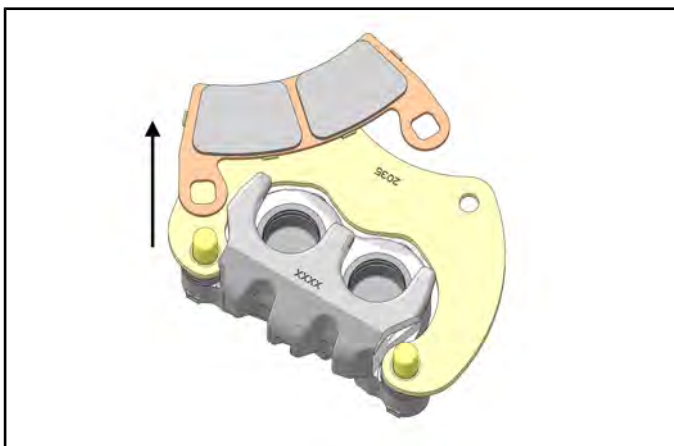

## Pad Inspection

1. Clean the caliper with brake cleaner or alcohol.
2. Measure the thickness of the pad material. Replace pads if worn beyond the service limit.

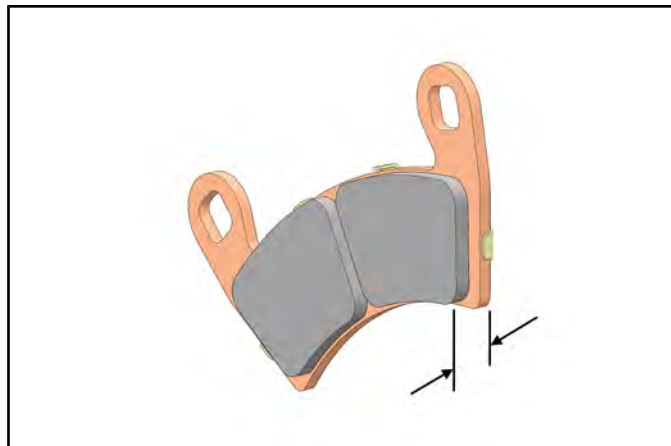

**Rear Brake Pad Thickness:**  
 $0.298 \pm 0.007$ " (7.57 mm  $\pm$  .178 mm)  
Service Limit: 0.180" (4.6 mm)

# BRAKES

## Pad Assembly / Installation

1. Lubricate mounting bracket pins with a light film of silicone grease and install rubber dust boots.



2. Compress mounting bracket and make sure dust boots are fully seated. Install pads with friction material facing each other.

### WARNING

If brake pads are contaminated with grease, oil, or liquid soaked do not use the pads. Use only new clean pads.

3. Install the caliper and torque the new mounting bolts (Item 1) to specification.

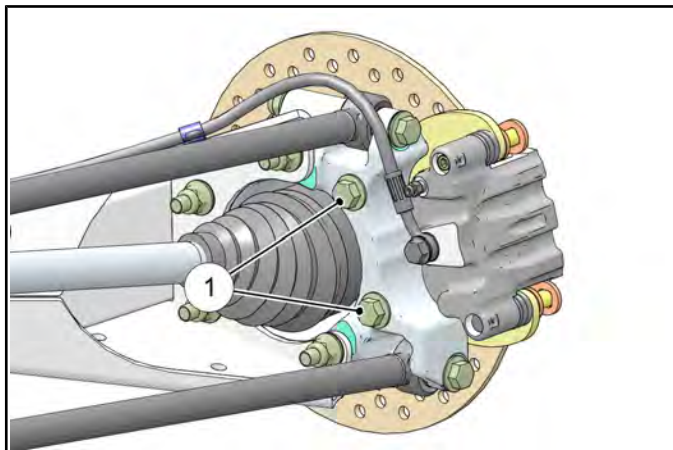

 = T

Rear Caliper Mount Bolt (Item 1):  
**40 ft-lbs (54 Nm)**

4. Install lower radius rod bolt, washer and new nut. Torque to specification.

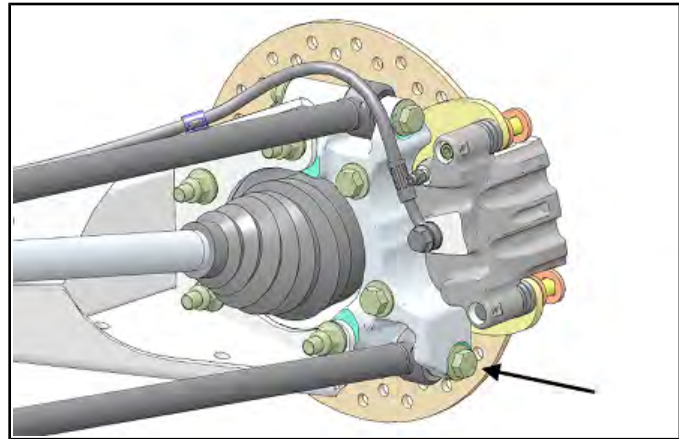

 = T

Radius Rod to Bearing Carrier Bolt:  
**40 ft-lb (54 Nm)**

5. Slowly pump the brake pedal until pressure has been built up. Maintain at least 1/2, (12.7 mm) of brake fluid in the reservoir to prevent air from entering the brake system.
6. Install the adjustment set screw and turn clockwise until the stationary pad contacts the disc, then back off 1/2 turn.
7. Verify fluid level in reservoir is up to the MAX line inside reservoir and install reservoir cap.

### Master Cylinder Fluid

**Up to MAX line inside reservoir**

8. Install wheel and torque wheel nuts to specification.

 = T

Wheel Nuts:  
**120 ft-lbs (163 Nm)**

### Brake Burnishing Procedure

It is required that a burnishing procedure be performed after installation of new brake pads to extend service life and reduce noise.

Start machine and slowly increase speed to 30 mph. Gradually apply brakes to stop machine. Allow pads and disc to cool sufficiently during the procedure. Do not allow pads or disc to become hot or warping may result. Repeat this procedure 10 times. **Do not make more than 3 stops per 1 mile (1.6 km).**



# BRAKES

## REAR CALIPER SERVICE

### Caliper Assembly View

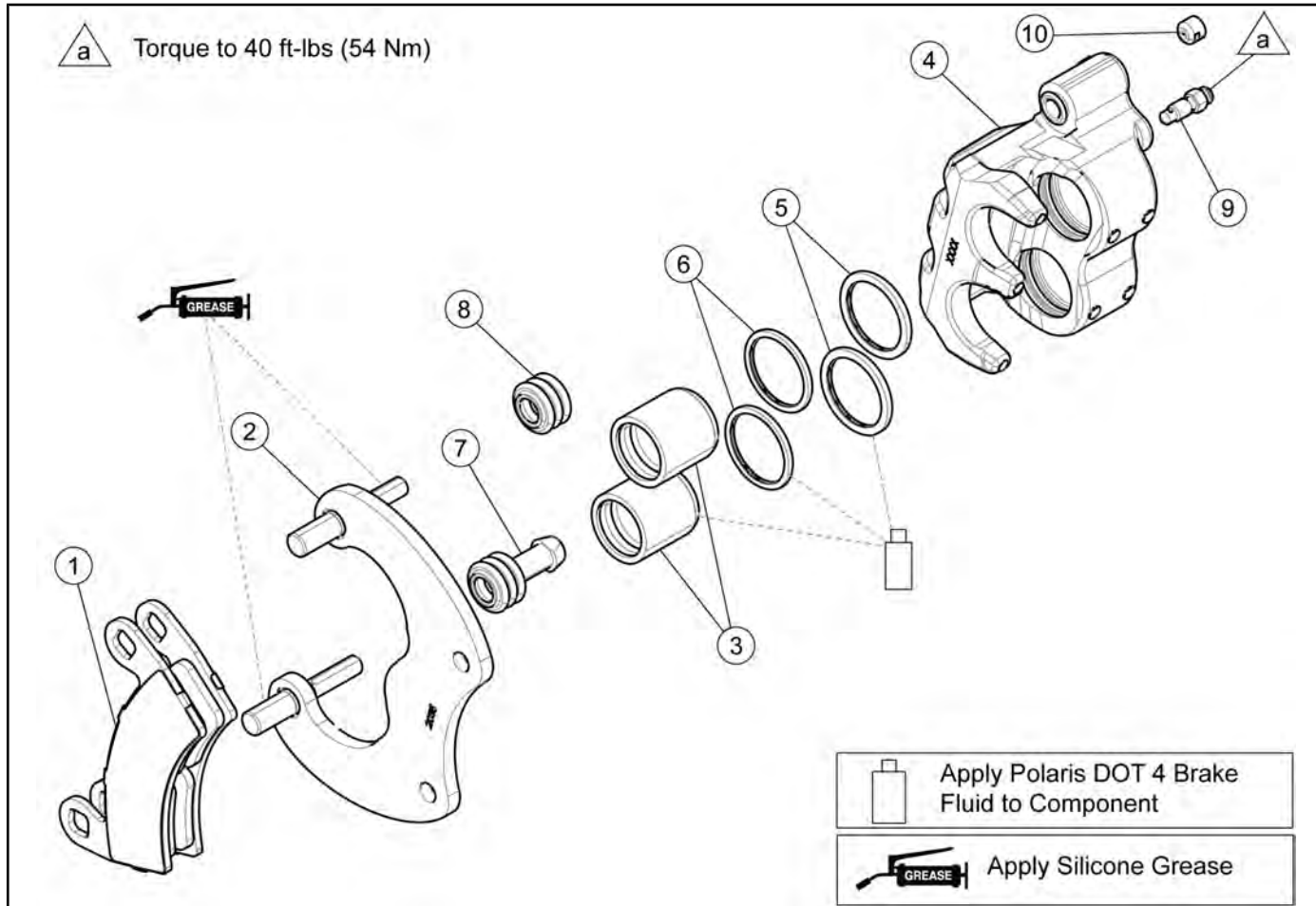

### Caliper Removal

1. Elevate and safely support the rear of the vehicle.

#### CAUTION

Use care when supporting vehicle so that it does not tip or fall. Severe injury may occur.

2. Remove the four wheel nuts and rear wheel. Clean caliper area before removal.

3. Place a container below the caliper to catch the brake fluid when removing the line (Item 1). Remove brake line from caliper.

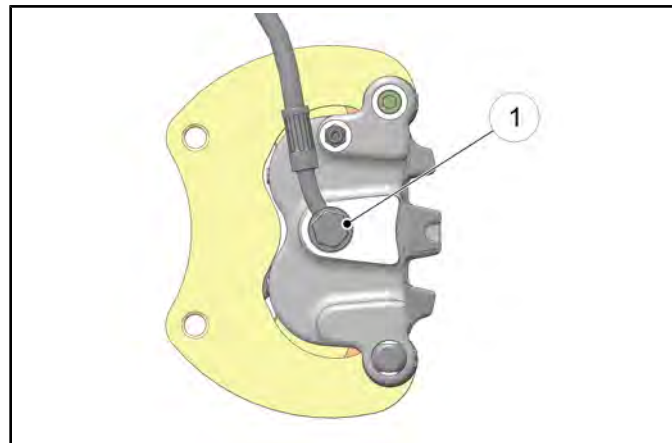

4. Remove the lower radius rod outer mounting bolt, nut and washer from the bearing carrier. Swing radius rod down. Discard nut.

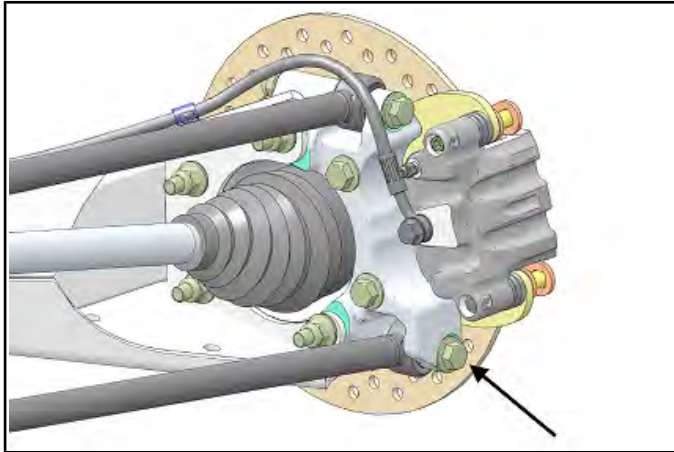

5. Loosen the brake pad adjustment set screw to allow brake pad removal after the caliper is removed.
6. Remove the two caliper mounting bolts and remove the caliper.

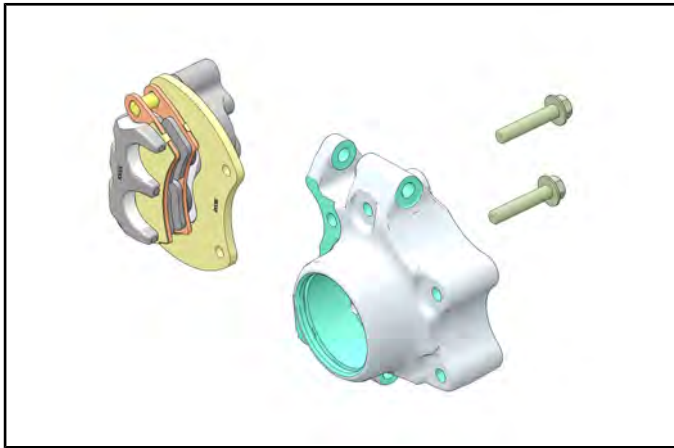

## Caliper Disassembly

1. Remove brake pad adjustment set screw (Item 9).
2. Push upper pad retainer pin inward and slip brake pads (Item 1) past the edge and remove from the caliper.
3. Remove mount bracket (Item 2) and dust boots (Item 6 and 7).

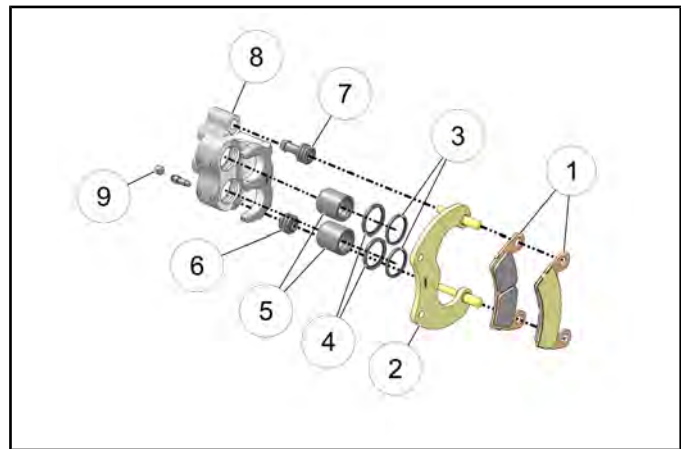

4. Using a hammer and a small punch, remove the piston (Item 5) from the caliper body (Item 8). Remove the square O-rings (Item 4) and (Item 3) from the caliper body (Item 8).
5. Clean the caliper body, piston, and retaining bracket (Item 10) with brake cleaner or alcohol.

**NOTE:** Be sure to clean caliper body seal grooves.

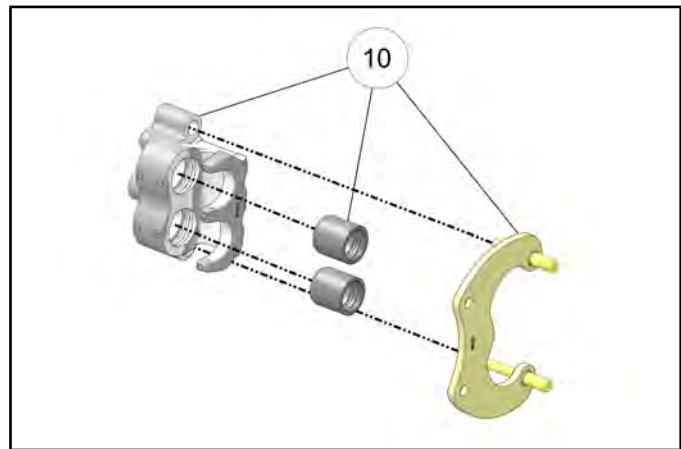

# BRAKES

## Caliper Inspection

1. Inspect caliper body for nicks, scratches or wear. Measure bore size and compare to specifications. Replace if damage is evident or if worn beyond service limit.

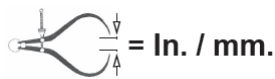

Rear Caliper Piston Bore I.D.:  
**Standard: 1.505" (38.23 mm)**  
**Service Limit: 1.507" (38.28 mm)**

2. Inspect piston for nicks, scratches, wear or damage. Measure diameter and replace if damaged or worn beyond service limit.

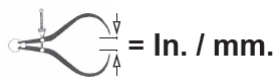
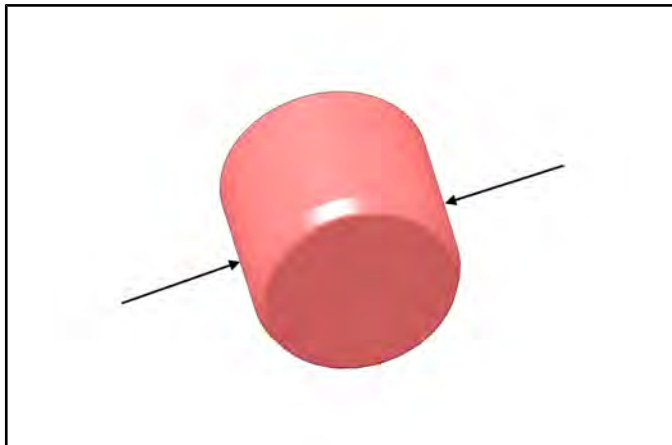

Rear Caliper Piston O.D.:  
**Standard: 1.500" (38.10 mm)**  
**Service Limit: 1.498" (38.05 mm)**

3. Inspect the brake disc and pads as outlined in this chapter.

## Caliper Assembly

1. Install new caliper seals (Item 1) in the caliper body (Item 2). Be sure groove is clean and free of residue or brakes may drag upon assembly.

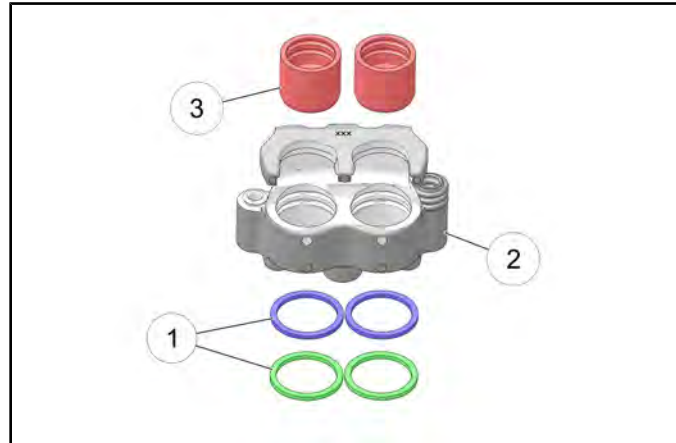

2. Coat piston with clean Polaris DOT 4 Brake Fluid (**PN 2872189**). Install piston (Item 3) with a twisting motion while pushing inward. Piston should slide in and out of bore smoothly with light resistance.
3. Lubricate the mounting bracket pins with silicone grease and install the rubber dust seal boots.

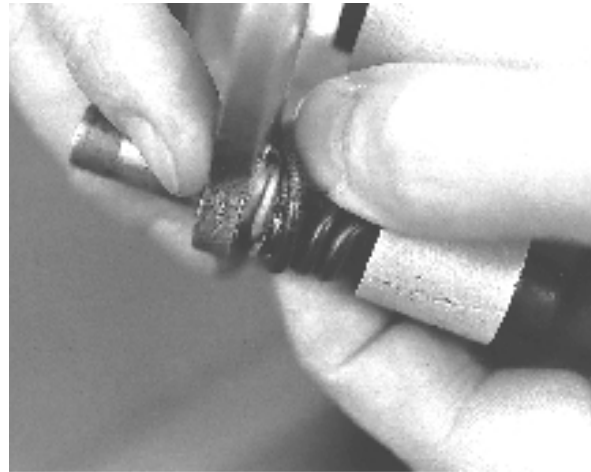

4. Compress the mounting bracket and make sure the dust seals are fully seated. Install the brake pads. Clean the disc and pads with brake parts cleaner or denatured alcohol to remove any dirt, oil or grease.

## Caliper Installation

1. Install the rear caliper with new mounting bolts. Torque mounting bolts (Item 1) to specification.

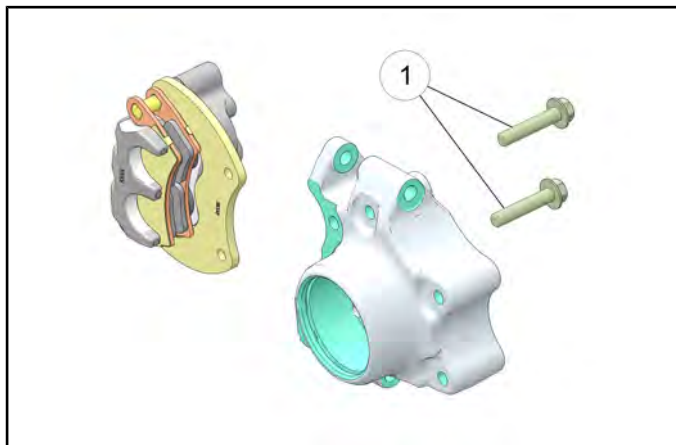

 = T

Rear Caliper Mount Bolt (Item 1):  
40 ft-lbs (54 Nm)

2. Install brake line banjo bolt (Item 2) and torque to specification.

**NOTE: Banjo Bolts:**  
15 ft-lbs (20 Nm)

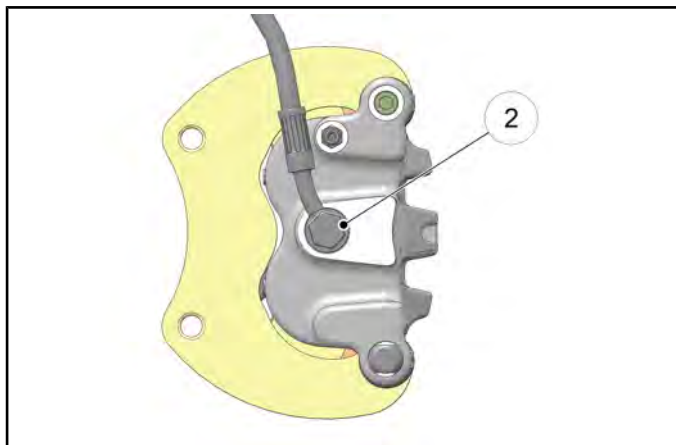

3. Install lower radius rod bolt, washer and new nut. Torque to specification.

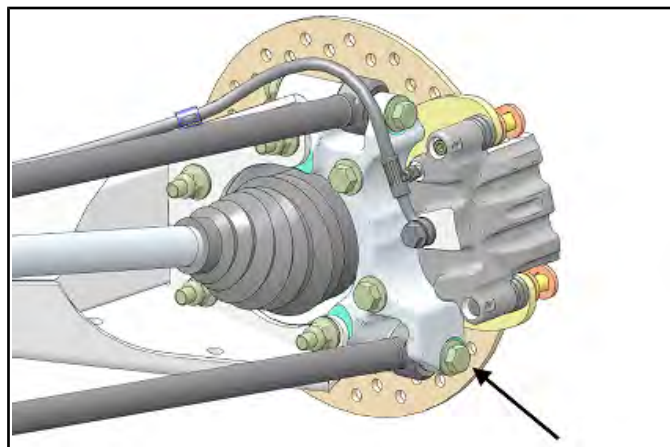

 = T

Radius Rod to Bearing Carrier Bolt:  
40 ft-lb (54 Nm)

4. Install the pad adjustment screw and turn until stationary pad contacts disc, then back off 1/2 turn.
5. Follow bleeding procedure outlined earlier in this chapter.
6. Install wheel and torque wheel nuts to specification.

 = T

Wheel Nuts:  
120 ft-lbs (163 Nm)

**NOTE: If new pads are installed, refer to Brake Burnishing Procedure, page 9.29.**

# BRAKES

## REAR BRAKE DISC

### Disc Inspection

1. Visually inspect disc for scoring, scratches, or gouges. Replace disc if deep scratches are evident.
2. Use a 0-1" micrometer and measure disc thickness at eight different points around the pad contact surface. Replace disc if worn beyond service limit.

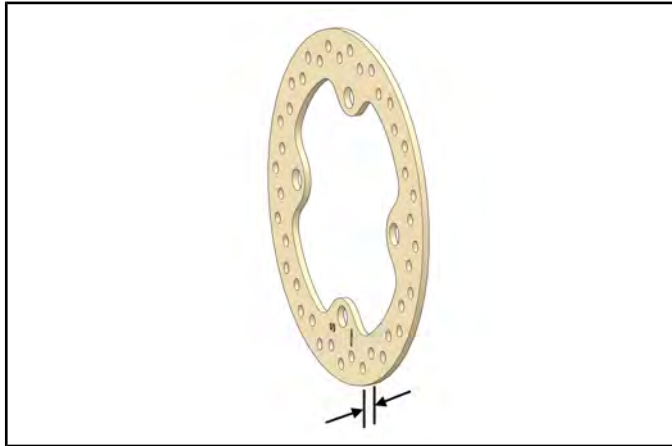

#### Brake Disc Thickness

**New: 0.188" (4.78 mm)**  
**Service Limit: 0.170" (4.32 mm)**

#### Brake Disc Thickness Variance

**Service Limit: 0.002" (0.051 mm)**  
**Difference Between Measurements**

3. Mount a dial indicator and measure disc runout. Slowly rotate the disc and read total runout on the dial indicator. Replace the disc if runout exceeds specifications.

**Brake Disc Runout:**  
**Service Limit: 0.010" (0.254 mm)**

### Disc Replacement

1. Remove rear brake caliper (see "REAR CALIPER SERVICE").
2. Remove wheel hub cotter pin (Item 4), castle nut (Item 3) and washers (Item 2).
3. Remove the hub assembly from the vehicle and remove the four bolts (Item 1) retaining the disc to the hub.

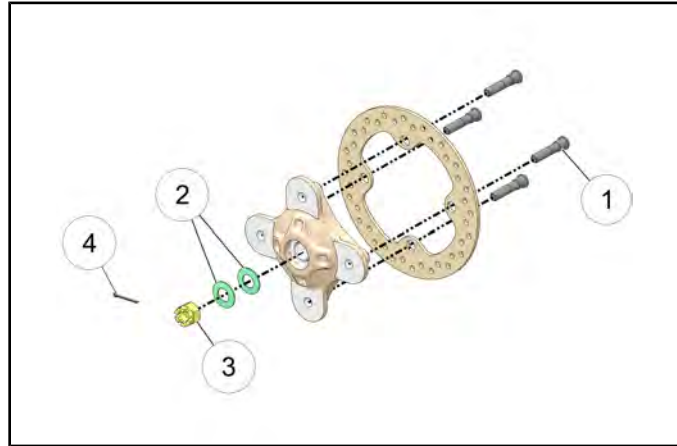

4. Clean the wheel hub mating surface and install new disc on wheel hub.
5. Install new bolts (Item 5) and torque to specification.

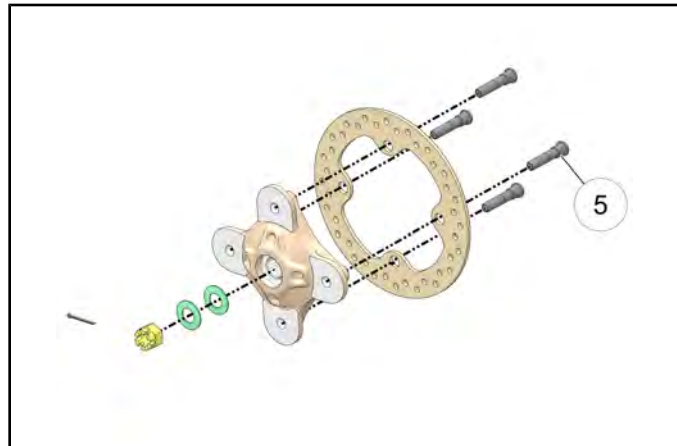

### CAUTION

Always use new brake disc mounting bolts. The bolts have a pre-applied locking agent which is destroyed upon removal.



**Brake Disc Mounting Bolts:**  
**30 ft-lb (41 Nm)**

6. Install wheel hub assembly, washers, and castle nut. Torque castle nut to specification and install a new cotter pin.

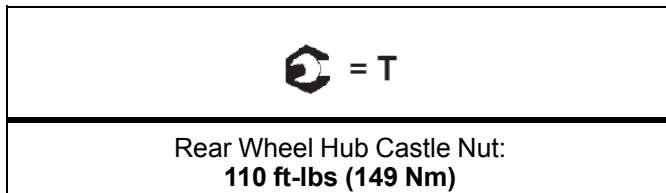

7. Install rear caliper (see REAR CALIPER SERVICE, page 9.30). Bleed the brake system. (See BRAKE BLEEDING / FLUID CHANGE, page 9.9).
8. Field test unit for proper braking action before putting into service. Inspect for fluid leaks and firm brakes. Make sure brakes do not drag when pedal is released. If the brakes drag, re-check assembly and installation.

## TROUBLESHOOTING

### **Brakes Squeal / Poor Brake Performance**

- Air in system
- Water in system (brake fluid contaminated)
- Caliper or disc misaligned
- Caliper dirty or damaged
- Brake line damaged or lining ruptured
- Worn disc and/or friction pads
- Incorrectly adjusted stationary pad
- Worn or damaged master cylinder or components
- Damaged break pad noise insulator
- Brake pads dragging
- Brake caliper dragging

### **Pedal Vibration**

- Disc damaged
- Disc worn (runout or thickness variance exceeds service limit)

### **Caliper Overheats (Brakes Drag)**

- Compensating port plugged
- Pad clearance set incorrectly
- Parking brake lever incorrectly adjusted (INT'L Model)
- Brake pedal binding or unable to return fully
- Parking brake left on (INT'L Model)
- Residue build up under caliper seals
- Operator riding brakes

### **Brakes Lock**

- Alignment of caliper to disc
- Caliper pistons sticking
- Improper assembly of brake system components



# CHAPTER 10

## ELECTRICAL

GENERAL INFORMATION .....	10.4
SPECIAL TOOLS .....	10.4
TORQUE SPECIFICATIONS .....	10.4
ELECTRICAL SERVICE NOTES .....	10.4
UNDER-DASH COMPONENTS .....	10.4
EFI DIAGNOSTICS .....	10.5
EFI COMPONENT TESTING .....	10.5
INSTRUMENT CLUSTER .....	10.6
OVERVIEW .....	10.6
RIDER INFORMATION DISPLAY .....	10.7
INFORMATION DISPLAY AREA .....	10.8
DIAGNOSTIC MODE.....	10.11
INSTRUMENT CLUSTER PINOUTS.....	10.12
INSTRUMENT CLUSTER REMOVAL.....	10.12
INSTRUMENT CLUSTER INSTALLATION .....	10.12
SWITCHES / CONTROLS .....	10.13
BRAKE LIGHT SWITCH.....	10.13
HEADLAMP SWITCH .....	10.13
IGNITION (KEY) SWITCH .....	10.14
IGNITION (KEY) SWITCH (INT'L).....	10.14
AWD / 2WD SWITCH.....	10.15
AWD / 2WD / TURF SWITCH (INT'L) .....	10.15
TURN SIGNAL SWITCH (INT'L) .....	10.16
HAZARD SWITCH (INT'L).....	10.16
TRANSMISSION (GEAR POSITION) SWITCH.....	10.16
PARKING BRAKE SWITCH (INT'L MODEL) .....	10.17
REAR DIFF SOLENOID (INT'L) .....	10.18
DIFFERENTIAL SOLENOID OVERVIEW .....	10.18
DIFFERENTIAL SOLENOID CIRCUIT OPERATION .....	10.18
ALL WHEEL DRIVE COIL .....	10.19
OPERATION OVERVIEW .....	10.19
DIAGNOSING SYSTEM FAILURES .....	10.19
VEHICLE SPEED SENSOR.....	10.20
SPEED SENSOR LOCATION .....	10.20
SPEED SENSOR TESTING .....	10.20
IGNITION COIL .....	10.20
OPERATION OVERVIEW .....	10.20
IGNITION COIL / HT LEAD REPLACEMENT.....	10.20
IGNITION COIL TESTS .....	10.21
HEAD LIGHTS .....	10.21
HEADLIGHT ADJUSTMENT.....	10.21
HEADLAMP REPLACEMENT .....	10.22



# ELECTRICAL

---

HEADLAMP INSTALLATION .....	10.23
TAIL / BRAKE LIGHTS .....	10.23
TAILLIGHT REPLACEMENT .....	10.23
COOLING SYSTEM .....	10.24
FAN CONTROL CIRCUIT OPERATION / TESTING .....	10.24
FAN CONTROL CIRCUIT BYPASS TEST .....	10.24
ENGINE COOLANT TEMPERATURE SENSOR (ECT) OVERVIEW .....	10.24
ECT SENSOR TEST .....	10.25
ECT SENSOR REPLACEMENT .....	10.25
FUEL SENDER .....	10.26
TESTING .....	10.26
FUSE BOX: FUSES / RELAYS / CIRCUIT BREAKER .....	10.27
OVERVIEW / OPERATION .....	10.27
FUSE BOX DETAIL .....	10.28
RELAY OPERATION .....	10.29
CHARGING SYSTEM .....	10.30
CURRENT DRAW - KEY OFF .....	10.30
CHARGING SYSTEM "BREAK EVEN" TEST .....	10.30
CHARGING SYSTEM STATOR (ALTERNATOR) TESTS .....	10.31
STATOR (ALTERNATOR) REPLACEMENT .....	10.32
REGULATOR / RECTIFIER .....	10.32
CHARGING SYSTEM TESTING FLOW CHART .....	10.33
BATTERY SERVICE .....	10.34
BATTERY SPECIFICATIONS .....	10.34
GENERAL BATTERY INFORMATION .....	10.34
BATTERY REMOVAL / INSTALLATION .....	10.35
BATTERY OFF SEASON STORAGE .....	10.35
BATTERY TESTING .....	10.35
OCV - OPEN CIRCUIT VOLTAGE TEST .....	10.35
LOAD TEST .....	10.35
BATTERY CONDUCTANCE ANALYZER .....	10.35
CHARGING PROCEDURE .....	10.36
STARTING SYSTEM .....	10.36
TROUBLESHOOTING .....	10.36
VOLTAGE DROP TEST .....	10.36
STARTER MOTOR REMOVAL .....	10.37
STARTER MOTOR INSTALLATION .....	10.37
STARTER SOLENOID BENCH TEST .....	10.37
STARTER SOLENOID OPERATION .....	10.37
STARTING SYSTEM TESTING FLOW CHART .....	10.38
CONDITION: STARTER FAILS TO TURN OVER THE ENGINE .....	10.38
ELECTRONIC POWER STEERING (EPS) .....	10.39
EPS OPERATION .....	10.39
PROPER EPS SYSTEM DIAGNOSING .....	10.39
EPS SYSTEM BREAKOUT .....	10.40
EPS TROUBLESHOOTING (POWER STEERING NON-FUNCTIONAL WITH MIL ON) .....	10.41
EPS TROUBLESHOOTING (POWER STEERING NON-FUNCTIONAL WITH MIL OFF) .....	10.42

# ELECTRICAL

---

- EPS TROUBLESHOOTING (USING DIGITAL WRENCH®)..... 10.43
- ELECTRICAL SYSTEM BREAKOUTS..... 10.44
  - AWD..... 10.44
  - VEHICLE SPEED SENSOR..... 10.45
  - COOLING SYSTEM..... 10.46
  - UNSWITCHED CHASSIS POWER..... 10.47
  - KEY-ON BATTERY POWER..... 10.48
  - LIGHTS..... 10.49
  - CHARGING SYSTEM..... 10.50

# ELECTRICAL

---

## GENERAL INFORMATION

### Special Tools

PART NUMBER	TOOL DESCRIPTION
PV-43568	Fluke™ 77 Digital Multimeter
PV-43526	Connector Test Kit
2870630	Timing Light
PU-50338	Battery Hydrometer
2460761	Hall Effect Sensor Probe Harness
2871745	Static Timing Light Harness
PU-50296	Battery Conductance Analyzer (MDX-610P)
PU-49466	Relay Bypass
-	Digital Wrench® (see Chapter 4)

**Bosch Automotive Service Solutions:** 1-800-345-2233  
or <http://polaris.service-solutions.com/>

### Torque Specifications

ITEM	TORQUE
Coolant Temperature Sensor	<b>17 ft-lb (23 Nm)</b>
Starter Mounting Fasteners	<b>7 ft-lb (10 Nm)</b>

### Electrical Service Notes

Keep the following notes in mind when diagnosing an electrical problem:

- Refer to wiring diagram for stator and electrical component resistance specifications.
- When measuring resistance of a component that has a resistance value under 10 Ohms, remember to subtract meter lead resistance from the reading. Connect the leads together and record the resistance. The resistance of the component is equal to tested value minus the lead resistance.
- Become familiar with the operation of your meter. Be sure leads are in the proper jack for the test being performed (i. e. 10A jack for current readings). Refer to the Owner's Manual included with your meter for more information.

- Voltage, amperage, and resistance values included in this manual are obtained with a Fluke™ 77 Digital Multimeter (PV-43568). This meter is used when diagnosing electrical problems. Readings obtained with other meters may differ.
- Pay attention to the prefix on the multimeter reading (K, M, etc.) and the position of the decimal point.
- For resistance readings, isolate the component to be tested. Disconnect it from the wiring harness or power supply.

### Under-Dash Components

The following switches and components can be accessed underneath the instrument / dash panel:

- Speedometer
- Digital Wrench® Diagnostic Connector
- AWD Switch
- Headlamp Switch
- 12 Vdc Accessory Power Point
- Ignition Switch
- Fuse / Relay Box

## EFI DIAGNOSTICS

### **EFI Component Testing**

All EFI component information and diagnostic testing procedures are located in **Chapter 4**.

Refer to Chapter 4 “Electronic Fuel Injection System (EFI)” when diagnosing an EFI system or component.

# ELECTRICAL

## INSTRUMENT CLUSTER

### Overview

The instrument cluster displays critical vehicle information to the user. Reference the following page for display functions and descriptions.

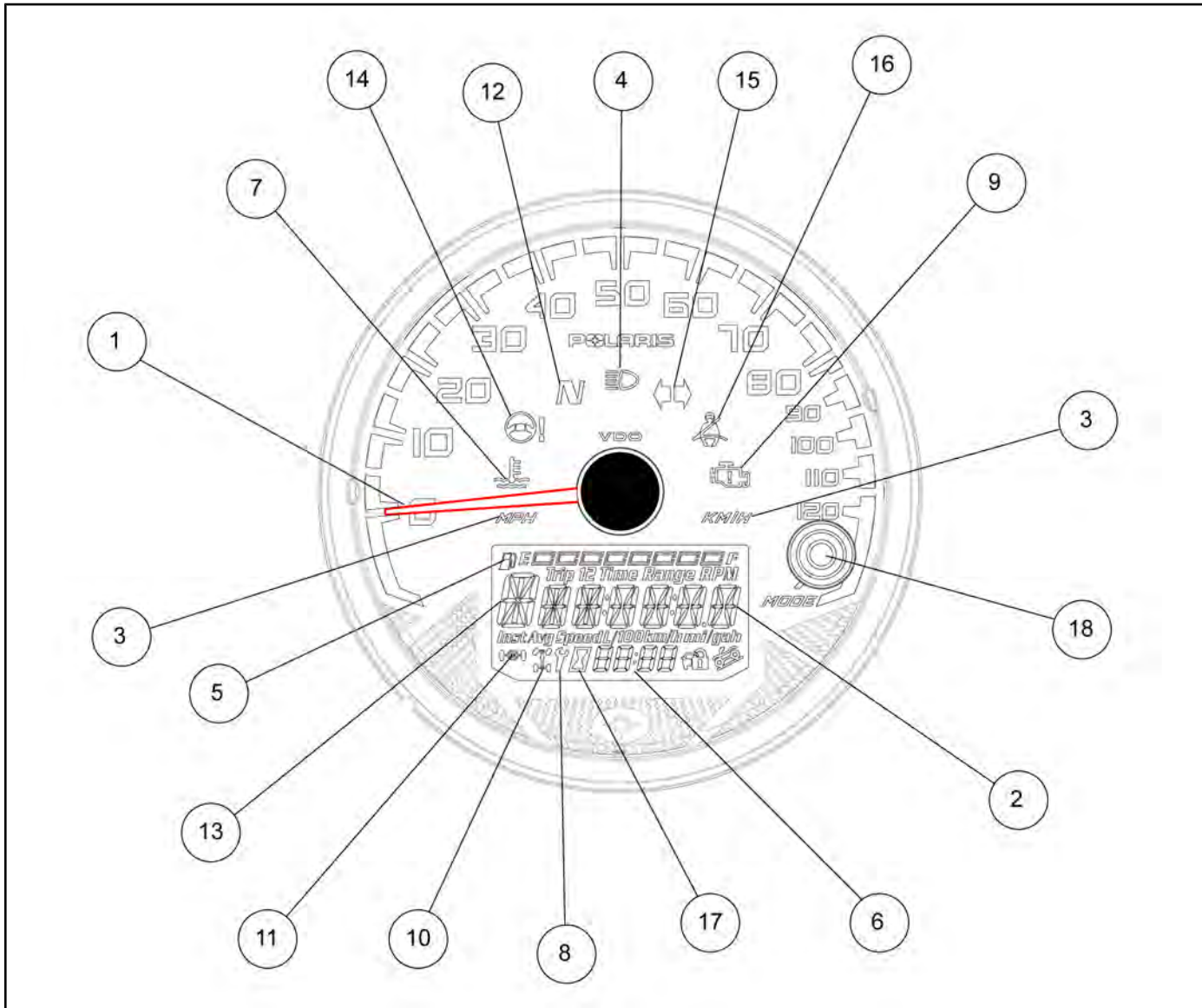

**NOTE:** Some features are not applicable to all models.

The use of a high pressure washer may damage the instrument cluster. Wash the vehicle by hand or with a garden hose using mild soap. Certain products, including insect repellents and chemicals, will damage the instrument cluster lens. Do not use alcohol to clean the instrument cluster. Do not allow insect sprays to contact the lens. Immediately clean off any gasoline that splashes on the instrument cluster.

## Rider Information Display

The rider information display is located in the instrument cluster. All segments will light up for 1 second at start-up.

**NOTE: If the instrument cluster fails to illuminate, a battery over-voltage may have occurred and the instrument cluster may have shut off to protect the electronic speedometer.**

1. **Vehicle Speed Display** - Analog display of vehicle speed in MPH or km/h.
2. **Information Display Area - Odometer / Trip Meter / Tachometer / Engine Temperature / Engine Hours / Service Info / Clock** - LCD display of the service hour interval, total vehicle miles or km., total engine hours, a trip meter, engine RPM and engine temperature.
3. **MPH / KM/H Display** - MPH is displayed when the instrument cluster is in the *Standard* mode. KM/H is displayed when the instrument cluster is in the *Metric* mode.
4. **High Beam Indicator** LED icon illuminates whenever the Headlamp switch is in the high beam position.
5. **Fuel Level Indicator** - LCD bar graph indicating current fuel level. All segments will flash when the last segment is cleared indicating a low fuel warning.
6. **Clock** - Displays current time in either 12-hour or 24-hour formats.
7. **Engine Temperature Indicator** - LED icon illuminates when the ECM determines the engine is overheating. The indicators will initially flash to indicate the engine is overheating. The indicators will stay lit and not flash if a severe overheating condition exists.
8. **Service Interval Indicator** - Preset at the factory and adjustable by the user, a flashing wrench symbol alerts the operator that the preset service interval has been reached and maintenance should be performed. The wrench icon will flash for 10 seconds upon start-up once it reaches 0.
9. **Check Engine MIL** - Illuminated when the ECM has detected a Diagnostic Trouble Code in the engine management system.
10. **AWD Indicator** - Illuminated when the AWD / 2WD switch is in the *AWD* position.
11. **TURF Indicator** - Illuminated when the AWD / TURF switch is in the *TURF* position (INT'L Model Only).
12. **Neutral Gear Indicator** - LED icon illuminates when gear selector is in the neutral (N) position.
13. **Gear Position Indicator** - Displays gear selector position.  
 H = High  
 L = Low  
 N = Neutral  
 R = Reverse  
 P = Park  
 – = Gear Signal Error (shifter stuck between gears)
14. **Power Steering System MIL** - LED icon illuminates when a fault has occurred with the power steering system. This indicator illuminates when the key is turned to the ON position and goes off when the engine is started (EPS Option Only).
15. **Turn Signal / Hazard Lamp Indicator** - LED icon illuminates whenever the LH, RH or hazard lamps are activated (INT'L Models Only).
16. **Helmet / Seat Belt Indicator** - LED icon illuminates for several seconds when the key is turned to the ON position. The lamp is a reminder to the operator to ensure all riders are wearing helmets and seat belts before operating the vehicle.
17. **Hours Indicator** - Illuminates when Hours are being displayed on the Information Display
18. **Mode Button** - Used to move through the menu features.

# ELECTRICAL

## Information Display Area

The LCD portion of the instrument cluster is the information display area. Information displayed in this area includes: odometer, trip meter, engine RPM, engine hours, service interval, clock, engine Diagnostic Trouble Codes (DTCs) and power steering DTCs.

### Odometer



The odometer records and displays the total distance traveled by the vehicle. The odometer can not be reset.

### Trip Meter

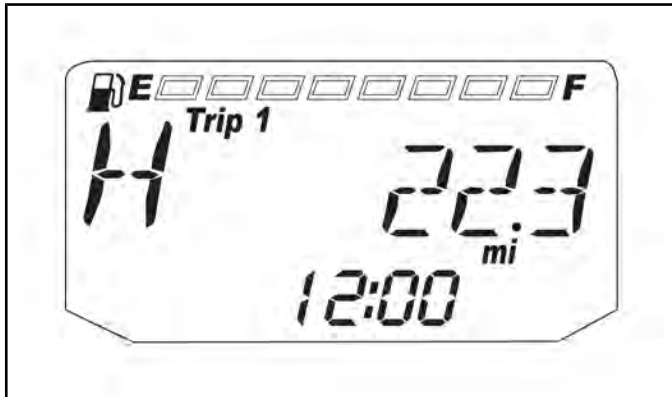

The trip meter records the miles traveled by the vehicle on each trip. To reset the trip meter:

1. Toggle the MODE button to TRIP 1.

2. To reset to 0, push and hold the MODE button until the distance display changes to 0.

### Tachometer (RPM)

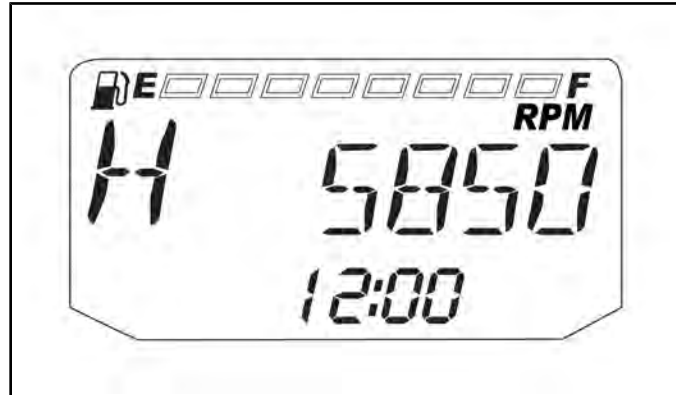

Engine RPM can be displayed digitally.

### Engine Temperature

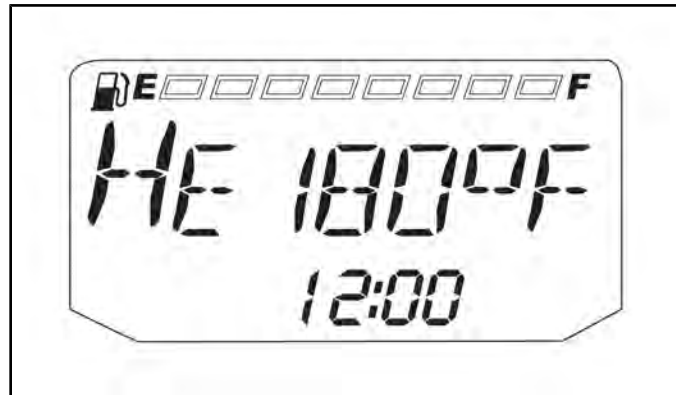

Engine temperature can be displayed in ° F or ° C. Refer to "Units of Measurement" to change the format.

### Engine Hours

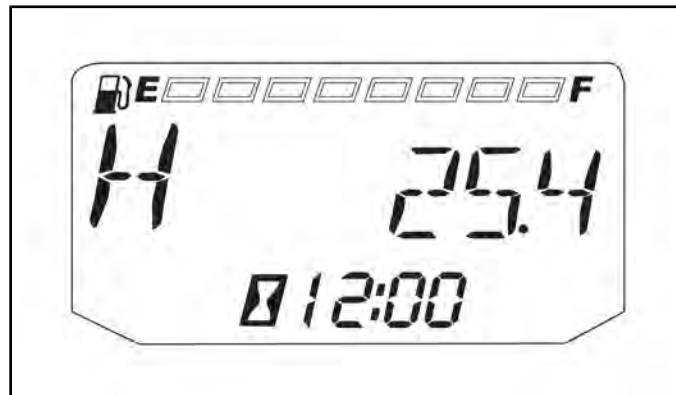

Engine hours are logged anytime the engine is running. Total hours can not be reset.

## Programmed Service Interval

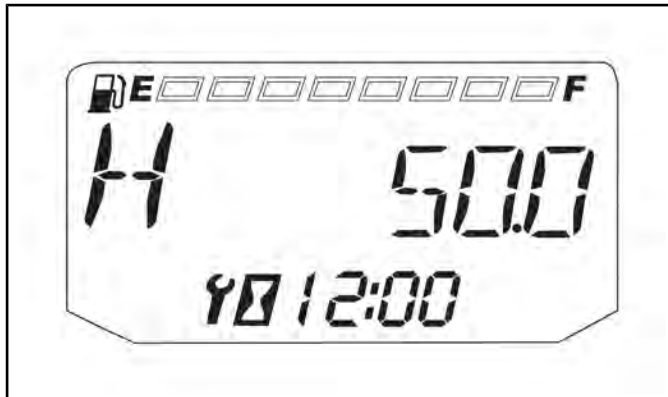

The initial factory service interval setting is 50 hours. Each time the engine is started, the engine hours are subtracted from the service interval hours. When the service interval reaches 0, the LCD wrench icon will flash for approximately 10 seconds each time the engine is started.

To change the hour setting or reset the function, follow these steps:

3. Toggle the MODE button until the wrench icon is displayed in the information area.
4. Press and hold the MODE button until the information display area begins to flash.
5. Toggle the MODE button to increase the service interval hours in 5 hour increments to a maximum of 100 hours.
6. To turn off the service interval function, toggle the MODE button until "OFF" is displayed.

## Clock



The clock displays the time in a 12-hour or 24-hour format. Refer to "Units of Measurement" to change the format (Standard 12-hour / Metric-24 hour). To set the clock, follow these steps:

7. Toggle the MODE button until the odometer is displayed.

8. Press and hold the MODE button until the hour segment flashes. Release the button.
9. With the segment flashing, tap the MODE button to advance to the desired setting.
10. Press and hold the MODE button until the next segment flashes. Release the button.
11. Repeat steps 3-4 twice to set the 10 minute and 1 minute segments. After completing the 1-minute segment, step 4 will save the new settings and exit the clock mode.

## Units of Measurement

	STANDARD DISPLAY	METRIC DISPLAY
Distance	Miles (MPH)	Kilometers (KM/H)
Time	12-Hour Clock	24-Hour Clock
Temperature	Fahrenheit	Celsius

To change between Standard and Metric units of measurement, follow these steps:

12. Turn the key to the OFF position.
13. Press and hold the MODE button while turning the key to the ON position.



## ELECTRICAL

14. When the display flashes the distance setting, tap the MODE button to advance to the desired setting.

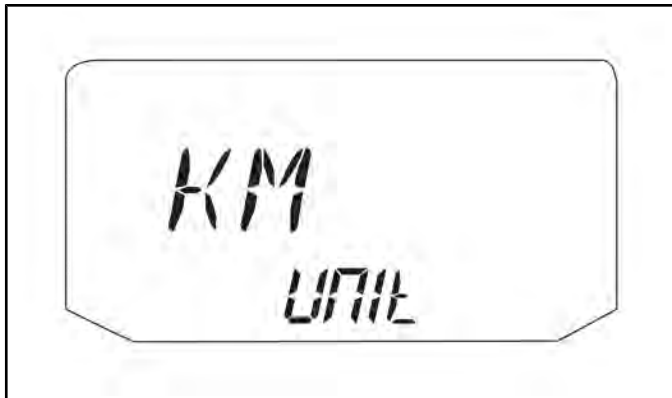
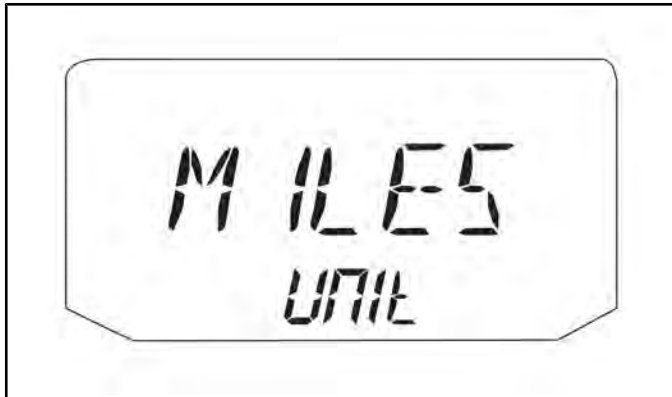

15. Press and hold the MODE button to save the setting and advance to the next display option.

16. Repeat the procedure to change remaining display settings.

### Under / Over Voltage

This warning usually indicates that the vehicle is operating at an RPM too low to keep the battery charged. It may also occur when the engine is at idle and a high electrical load is applied (lights, cooling fan or other accessories).

If battery voltage drops below 11 volts, a warning screen will display "Lo" and provide the present battery voltage. If voltage drops below 8.5 volts, LCD backlighting and icons will turn off.

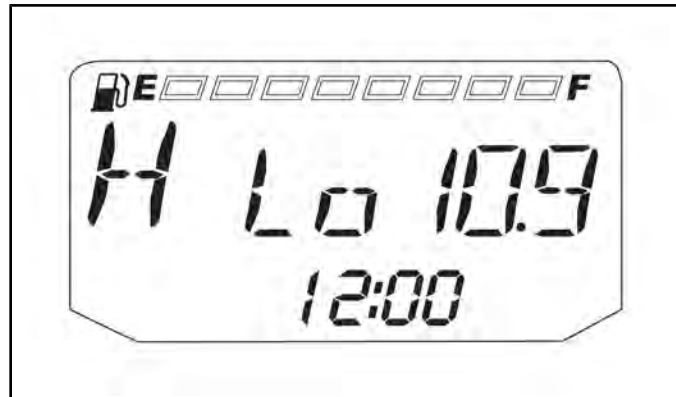

If battery voltage rises above 15 volts, a warning screen will display "OV" and provide the present battery voltage. If voltage rises above 16.5 volts, LCD backlighting and icons will turn off.

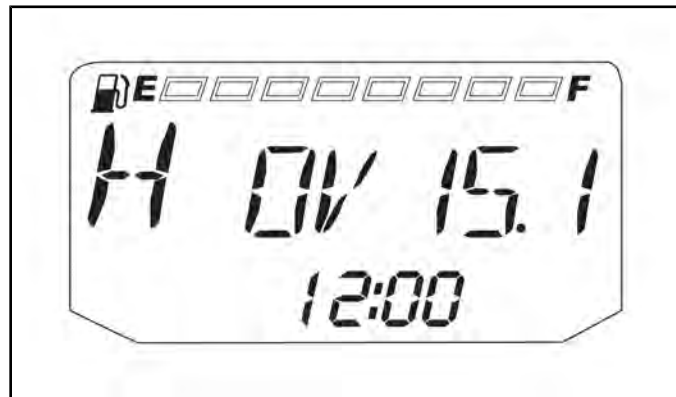

### Park Brake Indicator (INT'L Model Only)

This warning is used to notify the operator that the park brake lever is engaged.

When the park brake is fully engaged, "BRAKE" appears in the rider information display. Engine speed is limited to 1500 RPM in all gears, except

neutral. If throttle is applied, this limiting feature prevents operation, which protects the park brake pads from excessive wear.

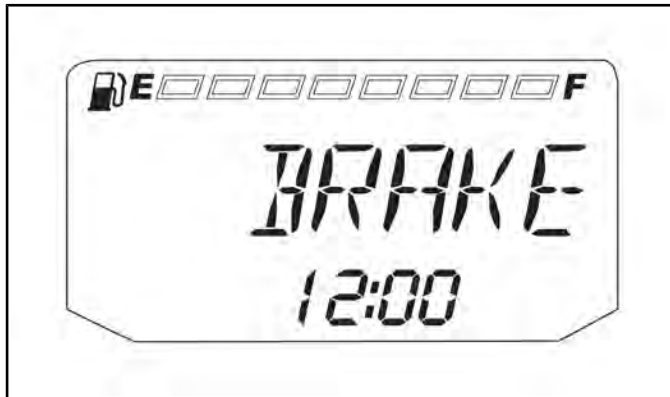

## Diagnostic Mode

The diagnostic mode is accessible only when the check engine MIL has been activated.

Use the following procedure to display diagnostic trouble codes that were activated during current ignition cycle causing the MIL to illuminate. Diagnostic trouble codes will remain stored in the gauge (even if MIL turns off) until the key is turned off.

1. If the trouble code (s) are not displayed, use the MODE button to toggle until "CK ENG" displays on the information display area.



2. Press and hold the MODE button to enter the diagnostics code menu.

3. A set of three numbers will appear in the information area.

- The first number (located far left) can range from 0 to 9. This number represents the total number of trouble codes present (example: 2 means there are 3 codes present).
- The second number (located top right) can be 2 to 6 digits in length. This number equates to the suspected area of fault (SPN).
- The third number (located bottom right) can be 1 to 2 digits in length. This number equates to the fault mode (FMI).

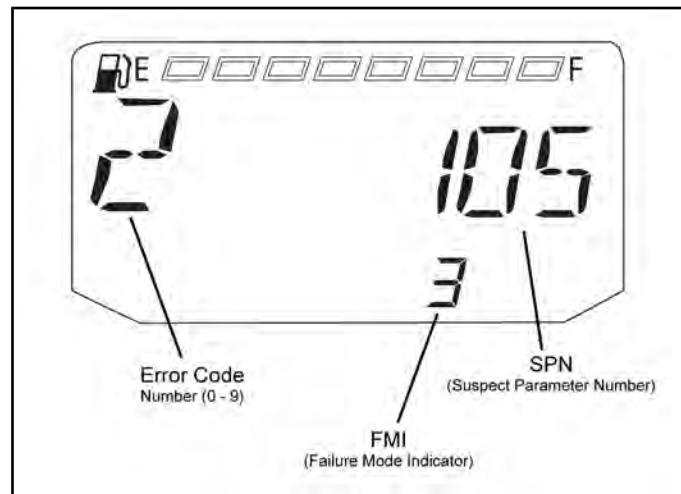

4. Use the trouble code reference table in the EFI Chapter for a description of each code (see Chapter 4).
5. If more than one code exists, press the MODE button to advance to the next trouble code.
6. To exit the diagnostic mode, press and hold the MODE button or turn the ignition key OFF once the codes are recorded.

**NOTE:** If there is a diagnostic problem with the power steering system, the power steering MIL will illuminate and blink in place of the check engine MIL.

# ELECTRICAL

## Instrument Cluster Pinouts

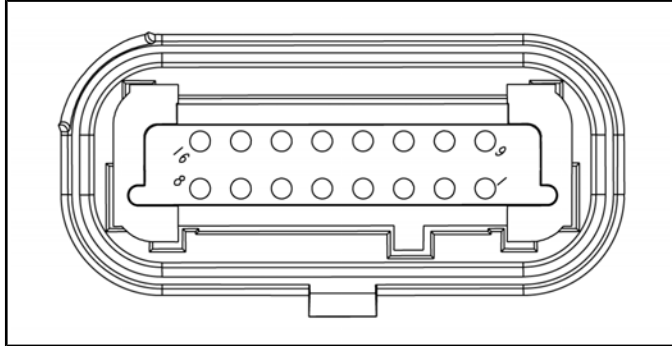

FUNCTION	PIN
CAN High	1
CAN Low	2
Switched Power (Vdc)	3
Constant Power (Vdc)	4
Ground	5
High Beam Input	8
Fuel Level Sensor	11
Ambient Air Temperature	15
<b>International Models Only</b>	
Turn Signal Input, LH	6
Turn Signal Input, RH	7

## Instrument Cluster Removal

**NOTE:** Do not allow alcohol or petroleum products to come in contact with the instrument cluster lens.

1. Disconnect the wire harness connector from the back side of the instrument cluster.

2. Push the instrument cluster (Item 3) out from the back side of the dash while securely holding the dash (Item 1) and rubber mount (Item 2).

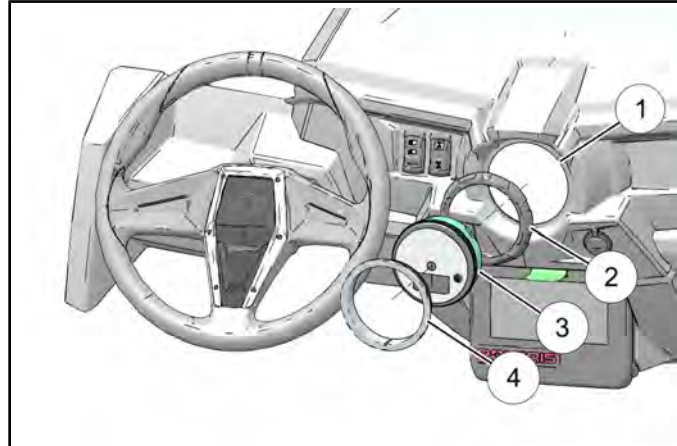

**NOTE:** Do not remove the rubber mount from the dash panel. Only remove the rubber mount if necessary. The bezel (Item 4) is a snap-on assembly and is a serviceable part.

## Instrument Cluster Installation

1. Spray a soap and water mixture onto the outer surface area of the instrument cluster. This will help the instrument cluster slide into the rubber mount more easily.

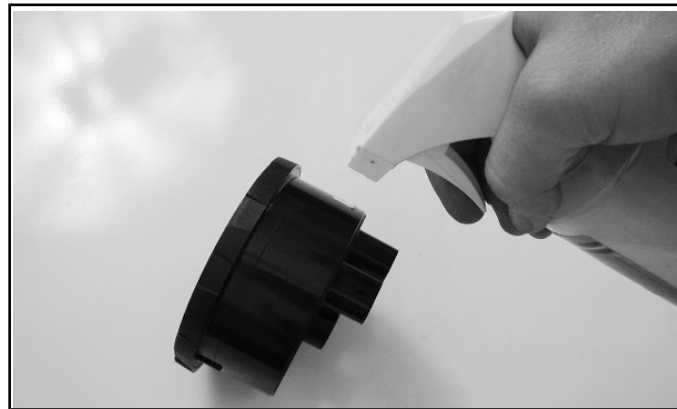

2. Be sure the rubber mount inside the dash is fully installed and that the indexing key on the rubber mount is lined up with the keyway in the dash.
3. Hold the dash securely and insert the instrument cluster into the dash. Twist the instrument cluster gently in a clockwise motion to properly seat the instrument cluster into the rubber mount. Apply pressure on the bezel while pressing down on the instrument cluster.

## SWITCHES / CONTROLS

### Brake Light Switch

1. The brake light switch (Item 1) is located on the front brake line banjo bolt of the master cylinder. The brake switch can be accessed through the left front wheel well opening.

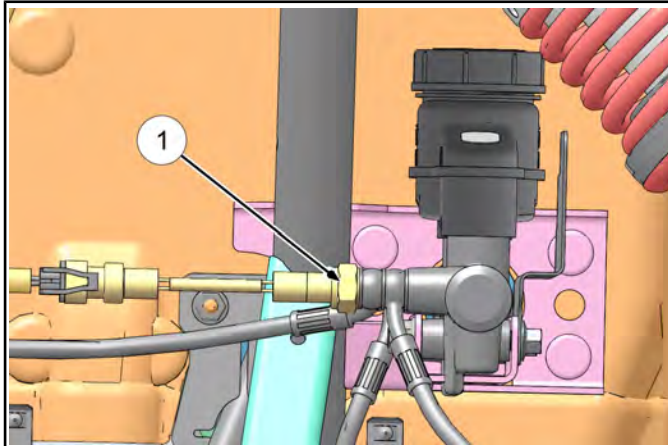

2. Disconnect wire harness from switch and connect an ohmmeter across switch contacts. The reading should be infinite (OL).
3. Apply the brake and check for continuity. If there is no continuity or if resistance is greater than 0.5 ohms, clean the switch terminals. Re-test and replace switch if necessary.
4. For switch replacement, refer to Chapter 9 "Brakes".

### Headlamp Switch

1. Disconnect the headlamp switch harness by depressing the connector locks and pulling on the connector. Do not pull on the wiring.
2. Test between the 3 sets of outputs (OFF / LOW / HIGH). If any of the tests fail, replace headlamp switch assembly.
  - Move the switch to HIGH. There should be continuity between switch pins 2 and 3; 5 and 6.
  - Move the switch to LOW. There should be continuity between switch pins 2 and 3; 4 and 5.
  - Move the switch to OFF. There should be continuity between switch pins 1 and 2; 4 and 5.

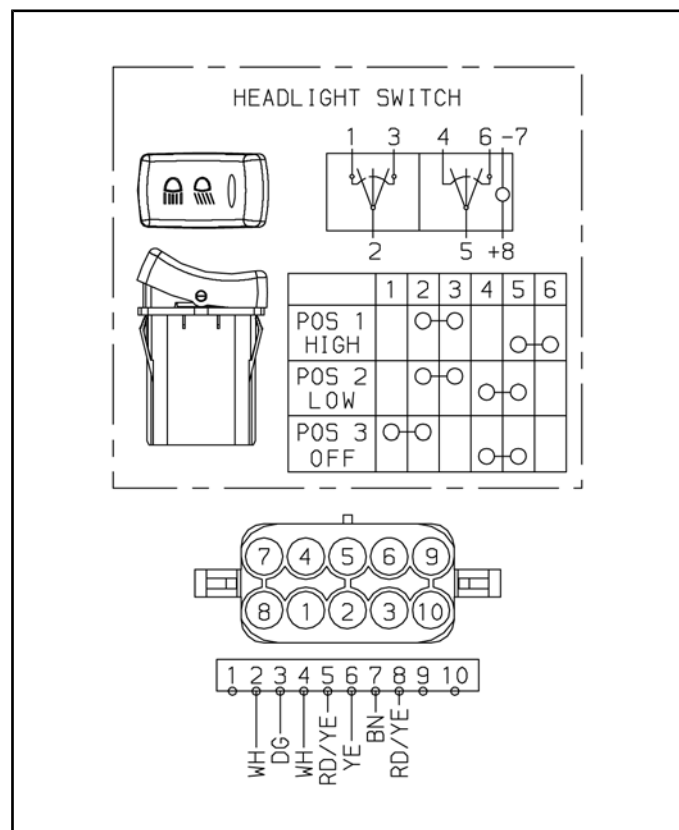

**NOTE:** Pins 7 and 8 provide power and ground to light the switch lamp.

# ELECTRICAL

## Ignition (Key) Switch

1. Disconnect the key switch harness by depressing the connector lock and pulling on the connector. Do not pull on the wiring.
2. Test between the 3 sets of outputs (OFF / ON / START). If any of the tests fail, replace ignition switch assembly.
  - Turn the ignition key to ON. There should be continuity between switch pins C and D.
  - Turn the ignition key to START. There should be continuity between switch pins A and B; C and D.

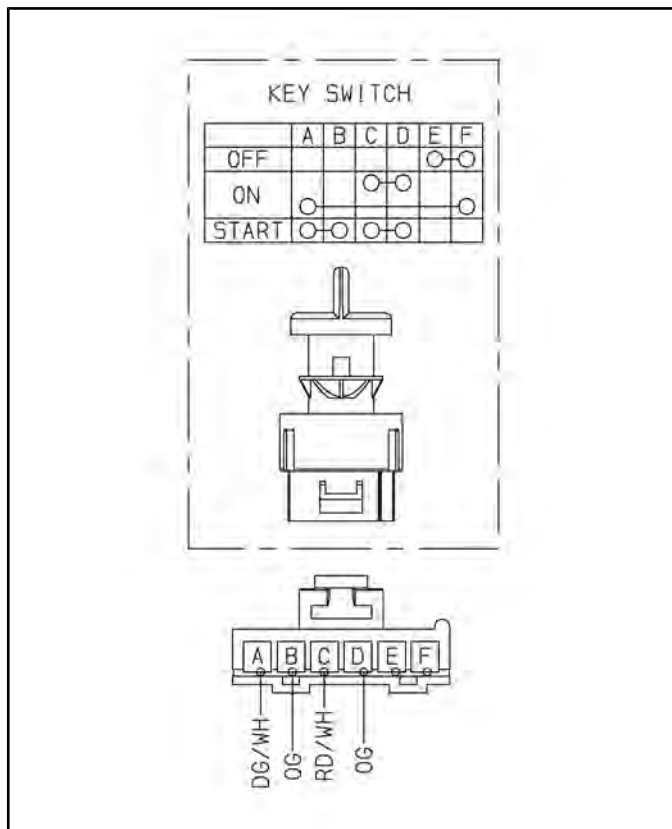

## Ignition (Key) Switch (INT'L)

1. Disconnect the key switch harness by lifting the connector lock and pulling on the connector. Do not pull on the wiring.
2. Test between the 4 sets of outputs (OFF / ON LIGHTS / ON / START). If any of the tests fail, replace ignition switch assembly.
  - Turn the ignition key to ON LIGHTS. There should be continuity between switch pins A, E and F; C and D.
  - Turn the ignition key to ON. There should be continuity between pins C and D; E and F.
  - Turn the ignition key to START. There should be continuity between pins A and B; C and D; E and F.

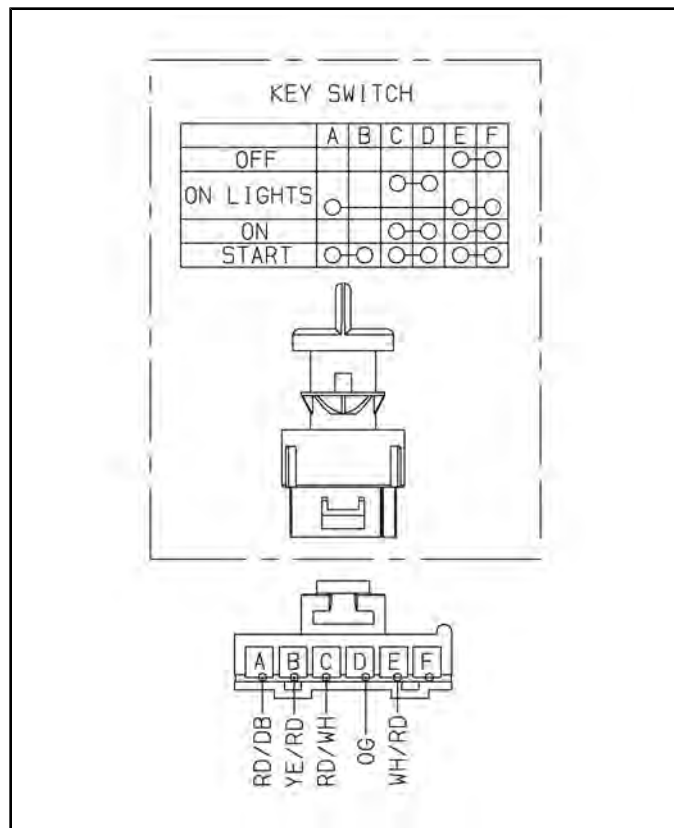

## AWD / 2WD Switch

1. Disconnect the AWD / 2WD switch harness by depressing the connector locks and pulling on the connector. Do not pull on the wiring.
2. Test between the 2 sets of outputs (AWD / 2WD). If any of the tests fail, replace the switch assembly.
  - Move the switch to AWD (ON). There should be continuity between switch pins 2 and 3.
  - Move the switch to 2WD (NONE / OFF). There should be no continuity between any pins.

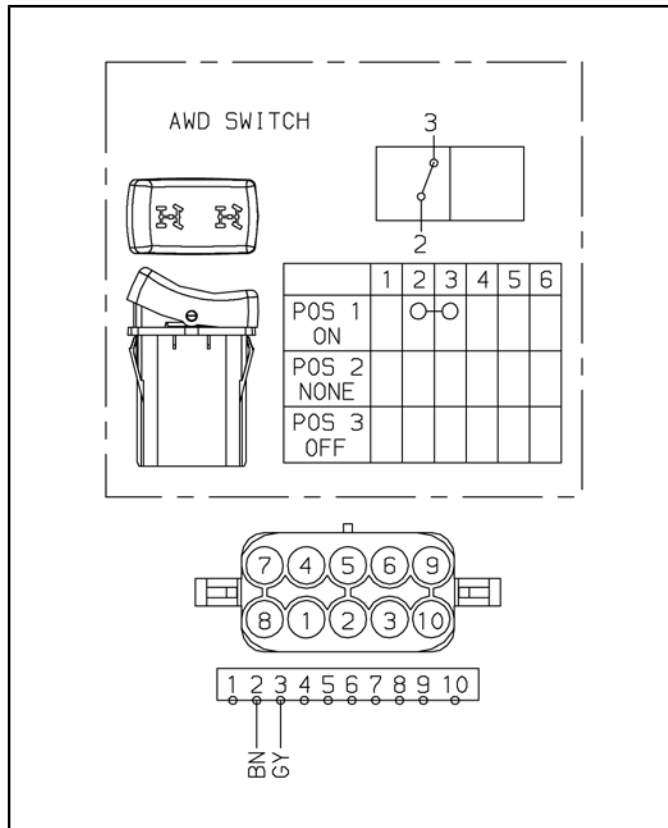

## AWD / 2WD / TURF Switch (INT'L)

1. Disconnect the AWD / 2WD / TURF switch harness by depressing the connector locks and pulling on the connector. Do not pull on the wiring.
2. Test between the 3 sets of outputs (AWD / 2WD / TURF). If any of the tests fail, replace the switch assembly.
  - Move the switch to AWD. There should be continuity between switch pins 2 and 3; 5 and 6.
  - Move the switch to 2WD. There should be no continuity between any pins.
  - Move the switch to TURF. There should be continuity between switch pins 1 and 2; 4 and 5.

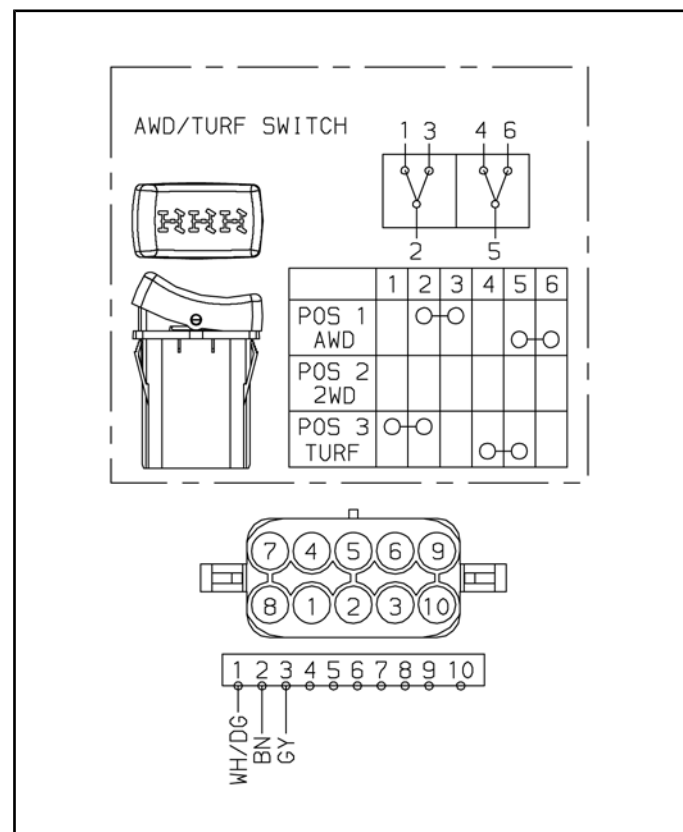

# ELECTRICAL

## Turn Signal Switch (INT'L)

1. Disconnect the Turn Signal switch harness by depressing the connector locks and pulling on the connector. Do not pull on the wiring.
2. Test between the 5 sets of outputs (HI BEAM / LO BEAM / L-TURN / R-TURN / HORN). If any of the tests fail, replace the switch assembly.

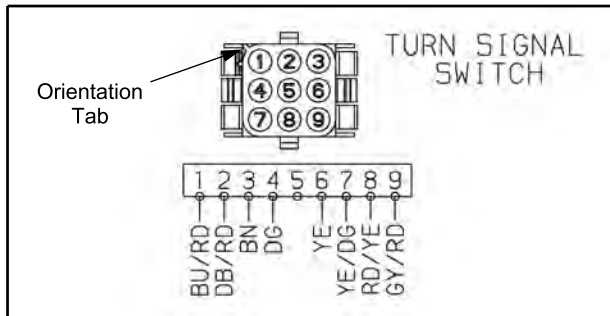

	1	2	3	4	6	7	8	9
HI BEAM					○	○		
LO BEAM				○	○	○		
L - TURN	○	○	○					
R - TURN		○	○					
HORN							○	○

## Hazard Switch (INT'L)

1. Disconnect wires or harness from the Hazard switch.
2. Test between the outputs (ON / NONE / OFF). If any of the tests fail, replace the switch assembly.
  - Move switch to ON. There should be continuity between switch pins 2 and 3.
  - Move switch to NONE / OFF. There should be no continuity between switch pins.

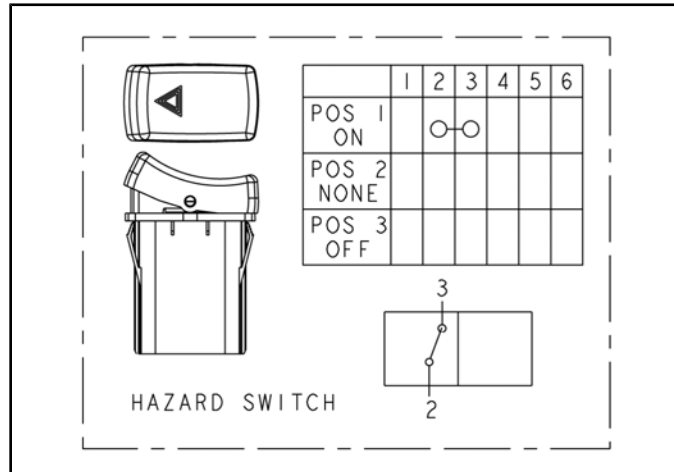

## Transmission (Gear Position) Switch

1. The transmission (gear position) switch is located on the RH side of the transmission and can be accessed through the RH wheel well area.
2. Disconnect the transmission switch harness by lifting the connector lock and pulling on the connector. Do not pull on the wiring.

- Test the transmission switch continuity readings for each gear position and compare to the specification table below.

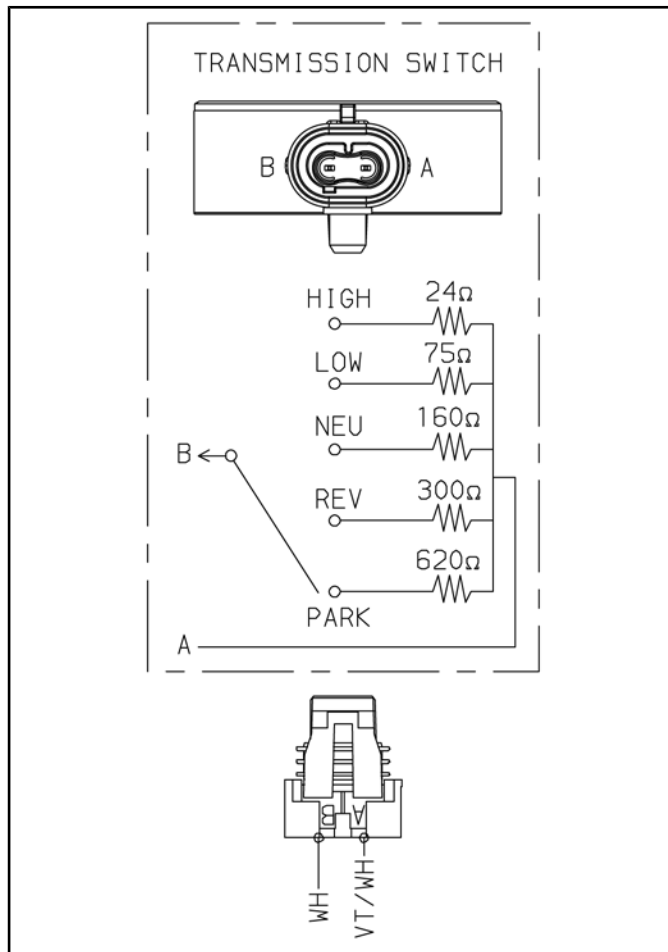

GEAR POSITION	RESISTANCE VALUE WHEN MEASURED AT SWITCH TERMINALS A AND B
HIGH	24 Ω
LOW	75 Ω
NEU	160 Ω
REV	300 Ω
PARK	620 Ω

## Parking Brake Switch (INT'L Model)

The parking brake switch is located within the parking brake lever. Remove the rubber boot covering the parking brake lever to locate the internally mounted switch.

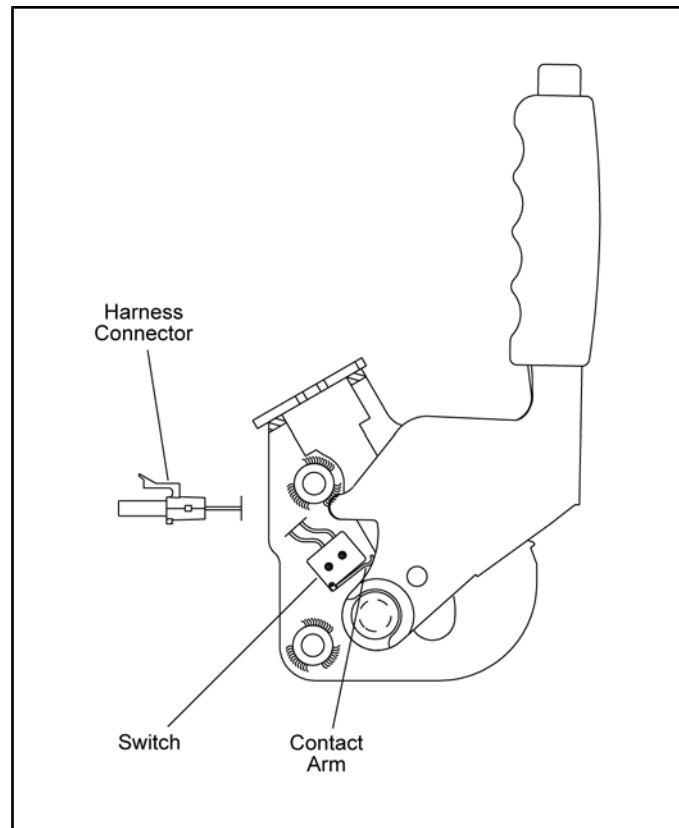

The switch remains in the “open” position when the park brake lever is not applied.

When the parking brake lever is applied, the switch makes contact and sends voltage to the ECU to illuminate “BRAKE” in the instrument cluster rider information display area (see “Park Brake Indicator”).

**NOTE:** If the parking brake is applied the ECU will rev limit the engine at 1500 RPM until the parking brake is released. This feature has been added to prevent drive-away with the parking brake applied.

### Testing The Parking Brake Switch

- Disconnect the harness connector at the parking brake switch (Orange/Red and Red/Blue wires).



# ELECTRICAL

- Place the ohmmeter leads onto the switch terminals. The reading should be infinite (OL).

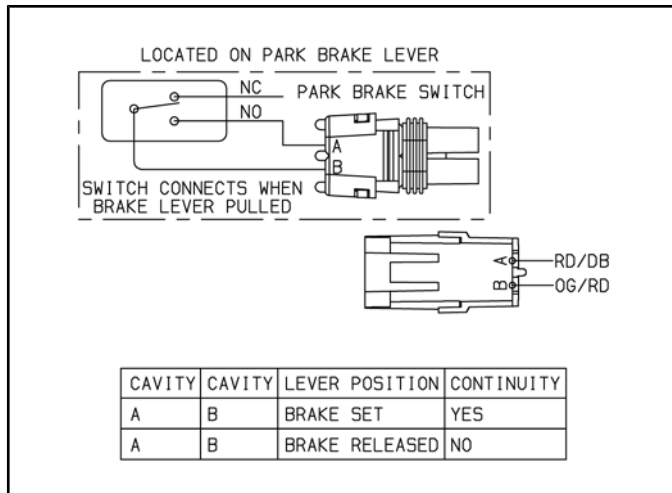

- Apply the parking brake. Continuity should now exist between the switch terminals. If no continuity exists when the parking brake is applied, try to clean the switch terminals and re-test. Replace switch if necessary.

### Park Brake Indicator

This warning is used to notify the operator that the park brake lever is engaged.

When the parking brake is fully engaged, "BRAKE" appears in the rider information display. Engine speed is limited to 1500 RPM in all gears, except neutral. If throttle is applied, this limiting feature prevents operation, which protects the park brake pads from excessive wear.

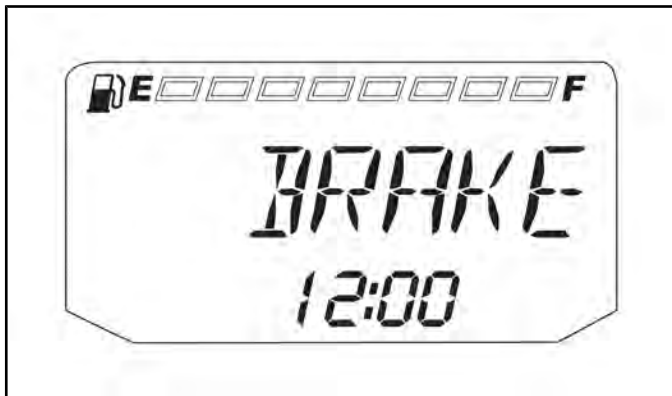

## REAR DIFF SOLENOID (INT'L)

### Differential Solenoid Overview

The differential solenoid is located on the rear portion of the transmission case. The solenoid actuates a shift fork with an engagement dog, which locks and unlocks the rear differential. Refer to Chapter 8 for more information.

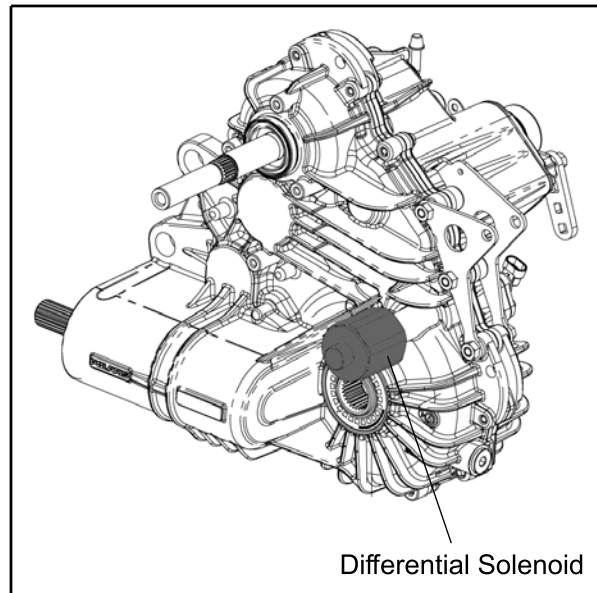

### Differential Solenoid Circuit Operation

The Rear Diff Solenoid Relay is attached to the lower airbox bracket and can be accessed through the right rear wheel well.

When the switch is pushed to activate "TURF", a ground signal is provided to the ECU from the AWD / 2WD / TURF Switch.

Depending on engine speed and gear position criteria, the ECU energizes the Rear Diff Solenoid Relay allowing it to enable the differential solenoid.

If the rear diff fails to switch from operational modes:

- Check the solenoid and relay connectors. Look for loose wires or bad connections.
- Check for power from the relay connector, to ensure the solenoid has power to be activated.
- Check the AWD / 2WD / TURF Switch wires for loose connections.
- Remove solenoid from rear differential and ensure the solenoid plunger is actuating.

## CAUTION

Do not power the solenoid with 12 Volts for more than 1 second, or damage may occur to solenoid.

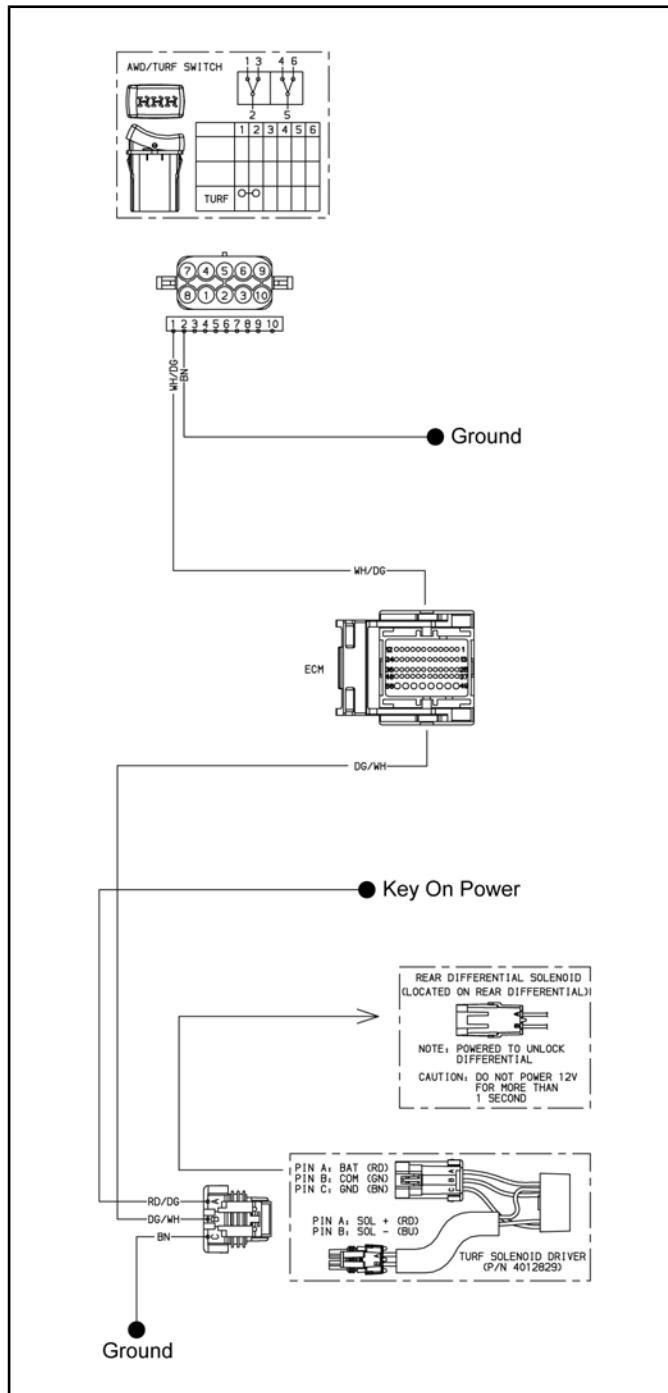

## ALL WHEEL DRIVE COIL

### Operation Overview

- When the key switch is “ON”, 12 VDC power is present at the hub coil.
- When the AWD switch is “ON”, and if the criteria is met, the Engine Controller provides a ground path (brown/white wire). When this occurs the AWD icon should display in the instrument cluster.
- The AWD system must be grounded to operate.

### Diagnosing System Failures

- Verify the AWD switch is functional and that a minimum of 11 volts is present at the hub coil.
- Verify the AWD hub coil is functional. Test the AWD hub coil using an ohm meter. See specifications below:

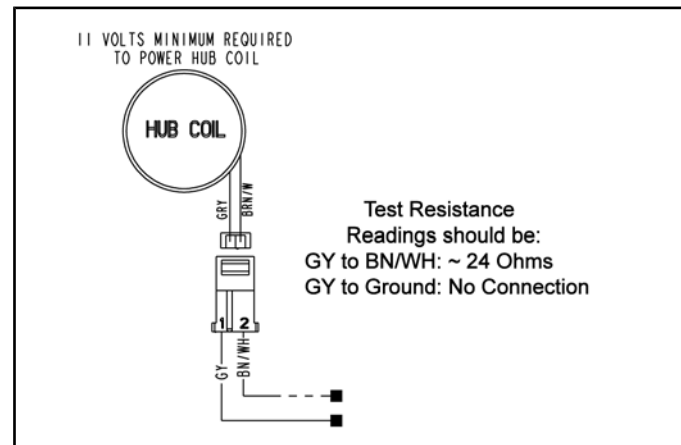

**AWD Hub Coil Resistance:  
24 Ω ± 5%**

- Verify the wiring harness, wiring, connectors, connector pins and grounds are undamaged, clean and connect properly.
- Verify continuity of wire connections with a known good volt/ohm meter.

**NOTE: Verify all wires and wiring connections have been tested properly with a known good volt/ohm meter before suspecting a component failure. 80% of all electrical issues are caused by bad/failed connections and grounds.**

10

# ELECTRICAL

## VEHICLE SPEED SENSOR

### Speed Sensor Location

The speed sensor (Item 1) is located on the RH side of the transmission, accessed through the rear RH wheel well.

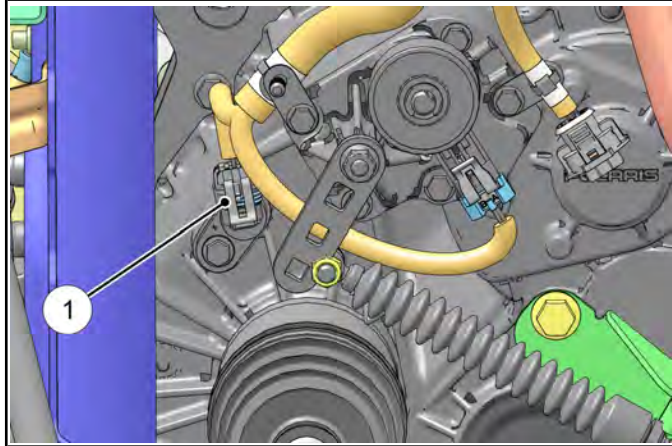

### Speed Sensor Testing

1. Disconnect the 3 wire harness from the speed sensor and remove the sensor from the transmission.
2. Connect the wires from the Static Timing Light Harness (2871745) to the sensor 3 pin connector using the Hall Sensor Probe Harness (2460761).
3. Pass a screwdriver back and forth in front of the sensor tip.
4. Be sure connections are good and 9V battery is in good condition. If the light flashes, the sensor is good.

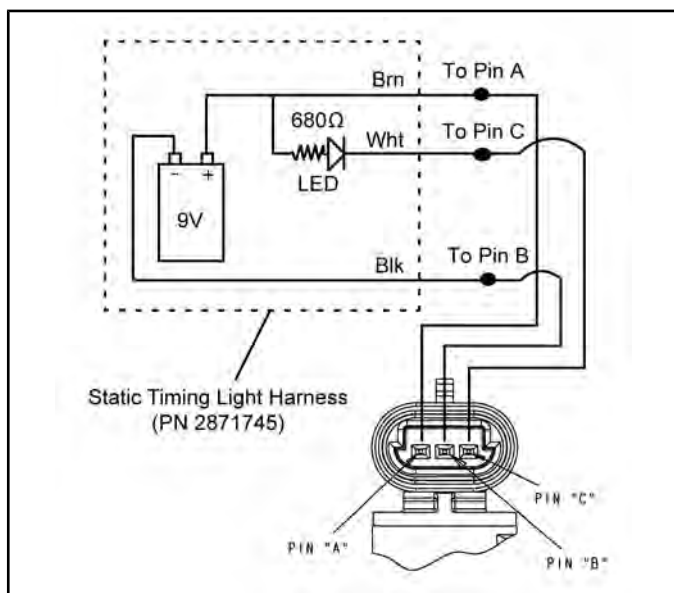

## IGNITION COIL

### Operation Overview

The ignition coil (Item 1) is used to provide high voltage to fire the spark plugs. When the ignition key is on, DC voltage is present in the primary side of the ignition coil windings. During engine rotation, an AC pulse is created within the crankshaft position sensor for each passing tooth on the flywheel's encoder ring. The encoder ring missing tooth creates an "interrupt" input signal, corresponding to specific crankshaft position. This signal serves as a reference for the control of ignition timing. The ECU then calculates the time interval between the consecutive pulses, and determines when to trigger the voltage spike that induces the voltage from the primary to the secondary coil windings to fire the spark plugs.

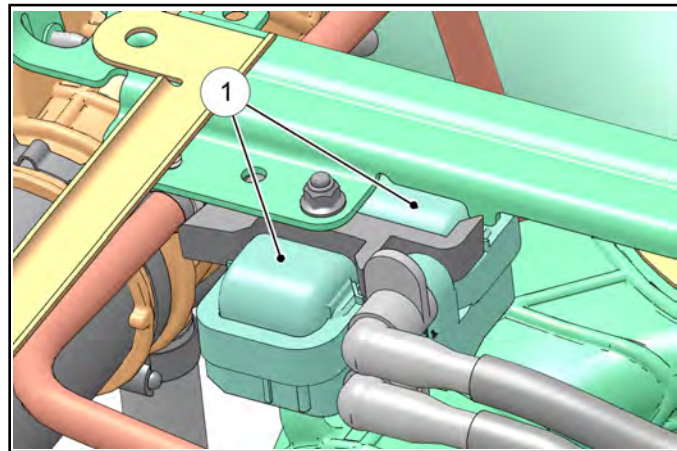

### Ignition Coil / HT Lead Replacement

**NOTE:** The engine will misfire if the spark plug wires are installed incorrectly. The spark plug wires are marked with PTO and MAG from the factory and should be installed to the corresponding cylinder and ignition coil post.

1. Remove the seats and engine service panel to access the ignition coil.
2. Disconnect the ignition coil harness and remove the high tension leads from the coil.
3. Remove the fastener retaining the ignition coil and remove it from the vehicle. If replacing the high tension lead(s), remove the other end of the lead(s) from the spark plug.
4. Install the new ignition coil and/or high tension lead(s).



Ignition Coil Retaining Bolt: **75 in-lbs (8.5 Nm)**

## Ignition Coil Tests

The ignition coil can be tested by using an ohm meter. Use the following illustration and specification table to test the ignition coil resistance.

TEST	PIN CONNECTION	RESISTANCE
Primary	Between 1 & 2 Between 2 & 3	0.4 $\Omega$
Secondary (PTO)	Between High Tension Lead Caps	7.0 k $\Omega$ $\pm$ 5%
Secondary (MAG)	Between High Tension Lead Caps	7.4 k $\Omega$ $\pm$ 5%

### Primary Test

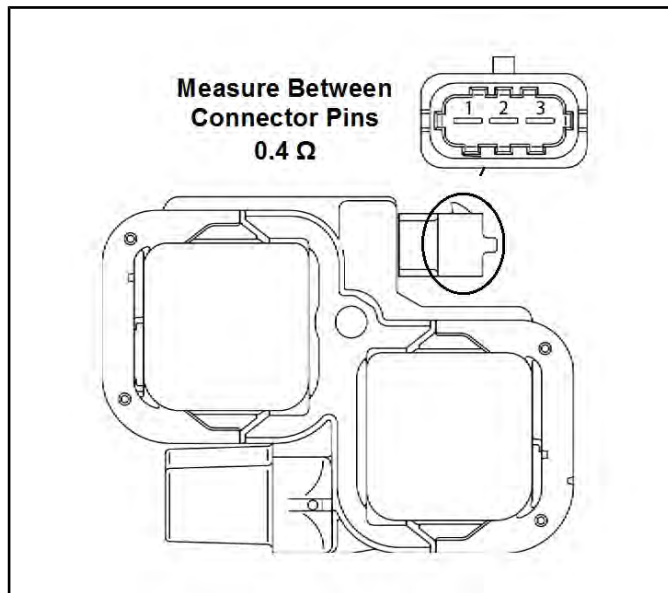

### Secondary Test

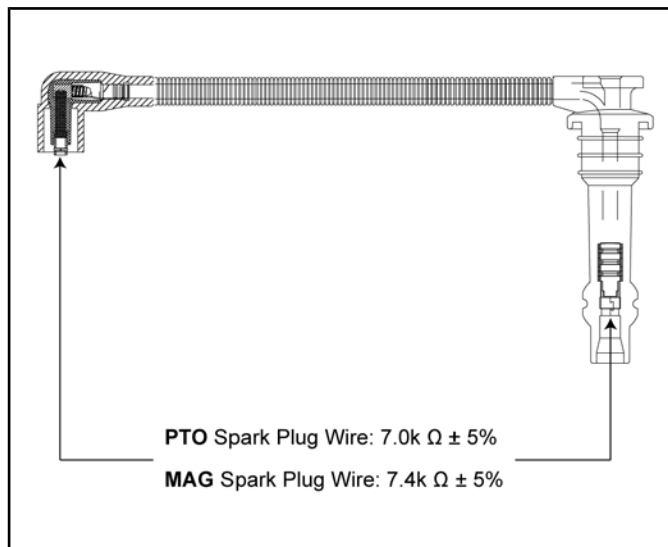

## HEAD LIGHTS

### Headlight Adjustment

The headlight beams are adjustable.

1. Place the vehicle on a level surface with the headlight approximately 25 ft. (7.6 m) from a wall.

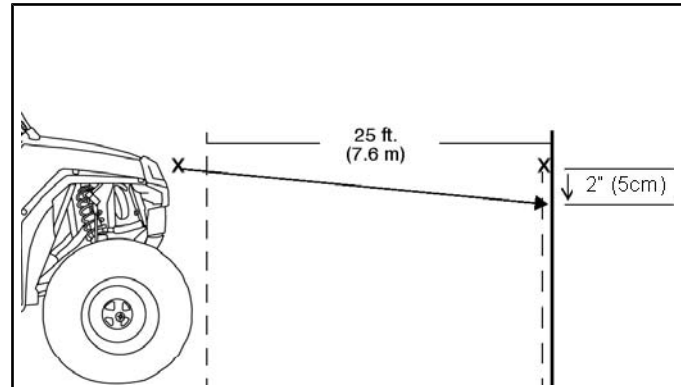

2. Measure the distance from the floor to the center of the headlight and make a mark on the wall at the same height.
3. With the machine in Park, start the engine and turn the headlight switch to the LOW position.
4. The most intense part of the LOW beam headlight beam should be aimed 2 in. (5 cm) below the mark placed on the wall in Step 2.

**NOTE: Rider weight must be included in the seat while performing this procedure.**

5. Adjust the beam to the desired position by loosening or tightening the (3) T-25 adjustment screws and moving the lamp to the appropriate height.

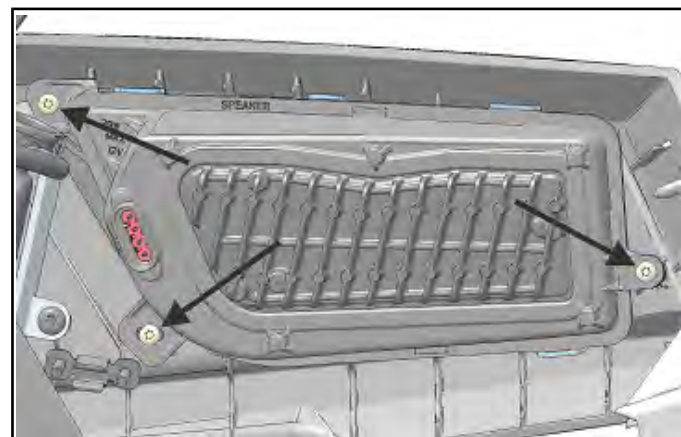

## ELECTRICAL

- Adjust the beam to desired position. Repeat the procedure to adjust the other headlight.

### WARNING

Due to the nature of light utility vehicles and where they are operated, headlight lenses become dirty. Frequent washing is necessary to maintain lighting quality. Riding with poor lighting can result in severe injury or death.

### Headlamp Replacement

- Disconnect wire harness from headlamp assembly. Be sure to pull on the connector, not on the wiring.

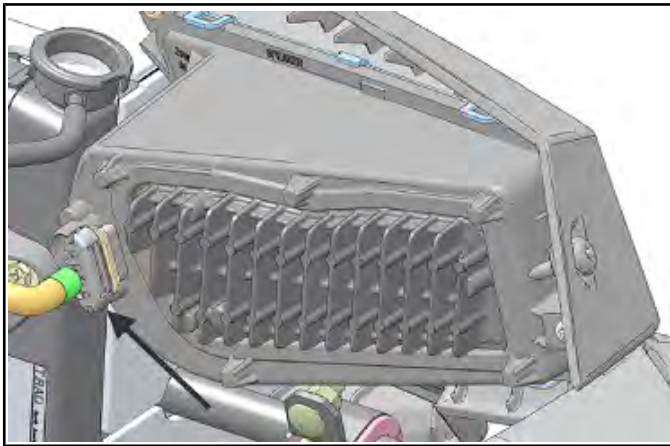

- Remove the three T-25 headlamp mounting screws (Item 1) and three adjustment preload springs (Item 2).

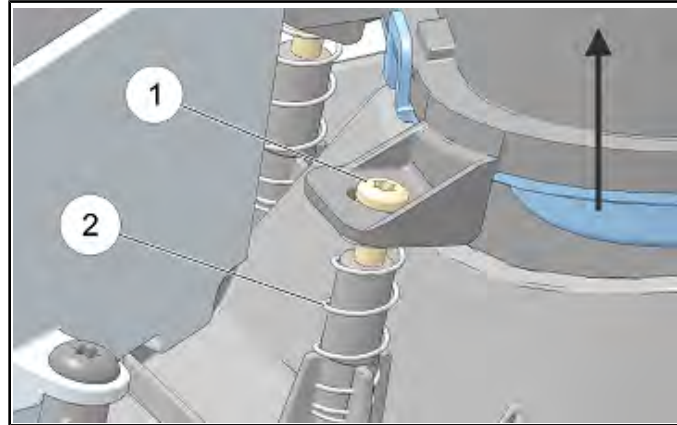

**NOTE:** The front bumper can be removed and placed face down on a suitable workbench to ease headlamp replacement (see Chapter 5).

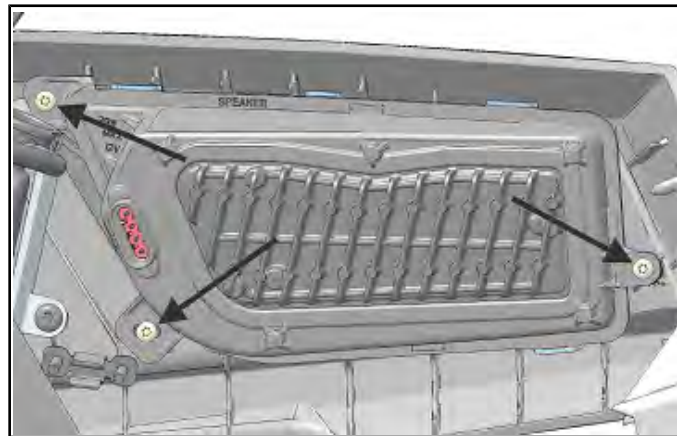

- Carefully lift and remove headlamp assembly from the bumper.

## Headlamp Installation

1. Install the headlamp adjustment springs onto the front bumper mounting bosses.
2. Insert the three T-25 headlamp mounting screws into the headlamp assembly mounting holes.
3. Maneuver the headlamp assembly into position. Be sure all three headlamp springs (Item 2) and mounting screws (Item 1) are properly aligned with mounting bosses (Item 3) on the front bumper.

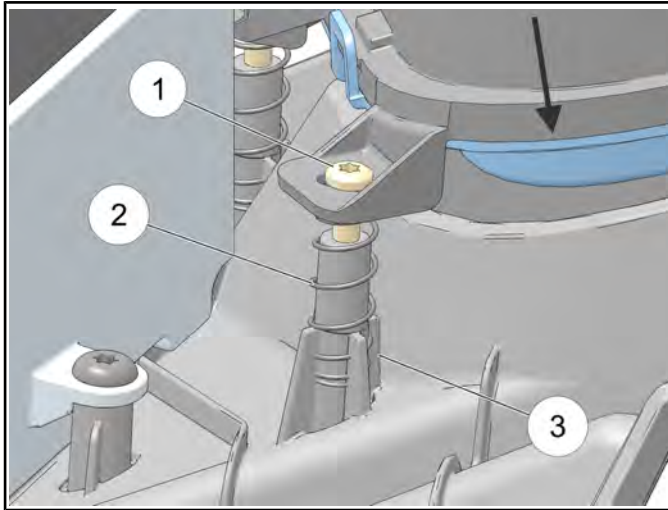

4. Fully tighten all three headlamp screws until the headlamp assembly is fully seated. Back headlamp mounting screws off 1/8" to 1/4" (2-3 turns).
5. Install the front bumper as shown in Chapter 5 if previously removed.
6. Connect headlamp electrical connector to the headlamp assembly.
7. Perform the "Headlight Adjustment" procedure as shown in this chapter.

## TAIL / BRAKE LIGHTS

### Taillight Replacement

Before replacing the taillight(s), use a digital multi-meter to test the harness to ensure the lamp is receiving 12 volts and that a ground path is present.

1. Disconnect the wire harness (Item 1).

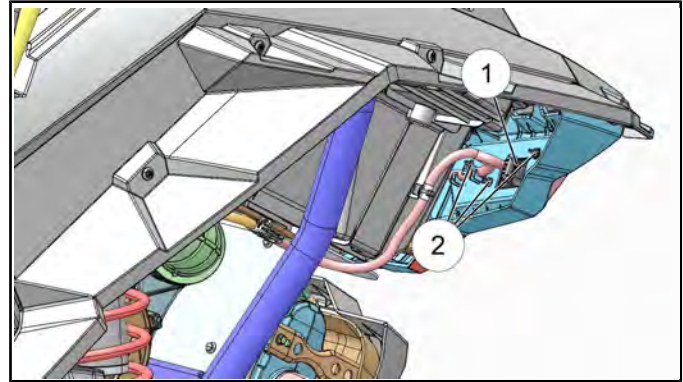

2. While holding the taillight assembly, remove the three nuts (Item 2) retaining the taillight assembly and remove it from the rear fascia.

# ELECTRICAL

## COOLING SYSTEM

### Fan Control Circuit Operation / Testing

Power is supplied to the fan via the Orange/Black wire when the relay is ON. The ground path for the fan motor is through the Brown harness wire. Refer to “RELAYS” later in this chapter for more information on fan functions.

#### CAUTION

Keep hands away from fan blades during operation.  
Serious personal injury could result.

**NOTE:** The fan may not function or operation may be delayed if coolant level is low or if air is trapped in the cooling system. Be sure cooling system is full and purged of air.

### Fan Control Circuit Bypass Test

1. Disconnect harness from coolant temperature sensor on the engine cylinder head (see Chapter 4).
2. With the transmission in Park, start the engine. After a few seconds, the fan should start running and the “Check Engine” indicator should display on the instrument cluster. This indicates all other components are working properly.
3. If the fan does not run or runs slowly, check the fan motor wiring, ground, motor condition, circuit breaker and mechanical relay for proper operation. Repair or replace as necessary. If the fan runs with the sensor harness disconnected, but will not turn on when the engine is hot, check the coolant temperature sensor and connector terminals.

### Engine Coolant Temperature Sensor (ECT) Overview

Mounted in the thermostat housing, the engine temperature sensor (Item 1) measures coolant temperature. The engine temperature sensor is a Negative Temperature Coefficient (NTC) type sensor, as the temperature increases the resistance decreases.

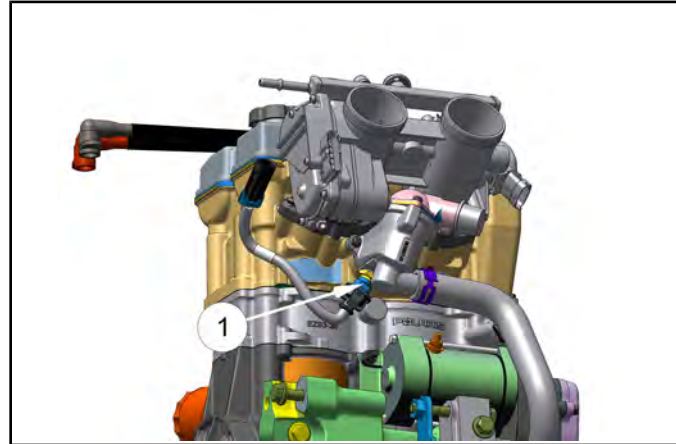

Coolant passes through the thermostat housing and by the sensor probe, varying a resistance reading which is relayed to the ECU. This signal is processed by the ECU and compared to its programming for determining the fuel and ignition requirements during operation. The ECU also uses this signal to determine when to activate the cooling fan during operation.

## ECT Sensor Test

To quickly rule out other components and wiring related to the ECT, disconnect the harness from the ECT sensor and start the engine. After a few seconds, the fan should turn on and the “Check Engine” indicator should display on the instrument cluster. This indicates all other components are working properly.

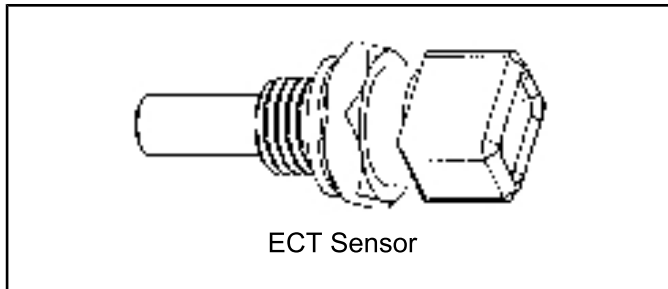

Refer to Chapter 3 and 10 for additional ECT sensor information. Polaris dealers can test the sensor by using Digital Wrench® Diagnostic Software (dealer only).

TEMPERATURE °F (°C)	RESISTANCE
68 °F (20 °C)	2.5 k Ω ± 6%
86 °F (30 °C)	1.7 k Ω ± 6%
104 °F (40 °C)	1.2 k Ω ± 6%
122 °F (50 °C)	834 Ω ± 6%
140 °F (60 °C)	596 Ω ± 6%
158 °F (70 °C)	435 Ω ± 6%
176 °F (80 °C)	323 Ω ± 6%
194 °F (90 °C)	243 Ω ± 6%
212 °F (100 °C)	186 Ω ± 6%

## ECT Sensor Replacement

1. Remove the throttle body. (see Chapter 4 – Throttle Body Removal).
2. Be sure the engine has cooled enough to work on.
3. Disconnect the vehicle harness from ECT sensor.
4. Drain the coolant so the level is below the sensor (see Chapter 2 “Coolant Drain / Fill”).
5. Using a wrench, remove and replace the sensor, applying a light coating of thread sealant to aid installation.

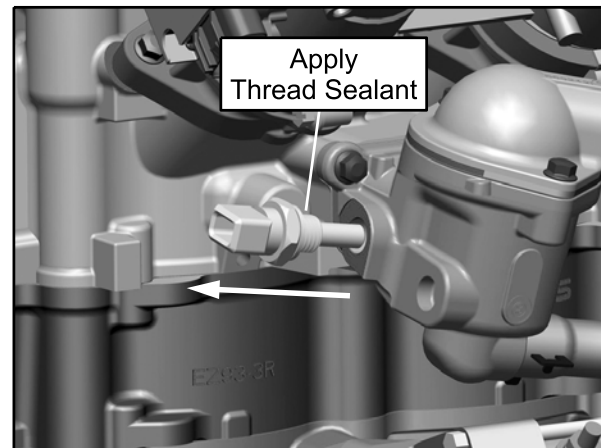

6. Torque the new ECT sensor to specification and connect the vehicle harness to the sensor.

= T
<b>ECT Sensor: 17 ft-lb (23 Nm)</b>

7. Reinstall the throttle body.
8. Add the required amount of coolant and bleed the system (see Chapter 3 “Cooling System Bleeding Procedure”).



# ELECTRICAL

---

## FUEL SENDER

### Testing

1. Remove the fuel pump assembly from the fuel tank (see Chapter 4 “Fuel Pump Replacement”).
2. Using an Ohm meter, measure the resistance of the fuel sender as shown below.

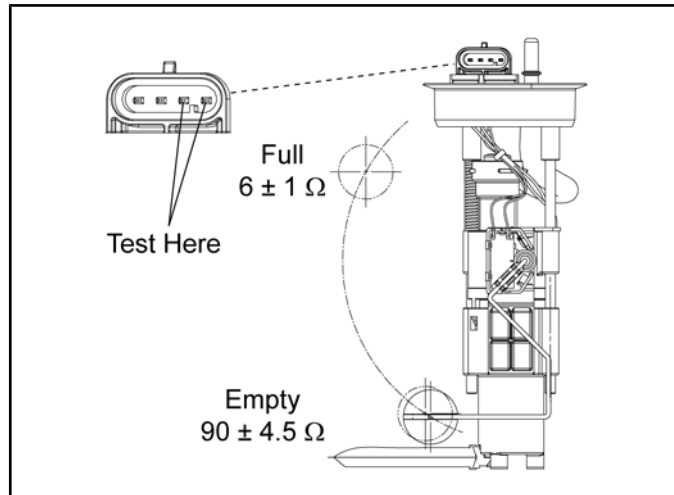

3. Allow the sender float to sit in the **empty position** and compare to specification.

**Fuel Sender - Empty:  $90 \pm 4.5 \Omega$**

4. Slowly move the sender float to the **full position** and compare to specification.

**Fuel Sender - Full:  $6 \pm 1 \Omega$**

5. If the readings are out of specification, or if the reading is erratic or LCD display “sticks”, check the following before replacing the fuel pump assembly:
  - Loose float
  - Float contact with tank
  - Bent float rod
6. If none of the conditions exist, the fuel sender assembly is faulty. Replace the fuel pump assembly (see Chapter 4).

## FUSE BOX: FUSES / RELAYS / CIRCUIT BREAKER

### Overview / Operation

Located in the fuse box under the dash, the fuses provide overload protection for wiring and components such as the instrument cluster, ECU, EFI system, main harness, lights, accessories and power steering. The relays assist with component operation like the cooling fan, fuel pump, EFI system, drive system and electronic power steering. A separate 20-amp circuit breaker protects the fan motor circuit. Two separate relays located under the dash operate the headlights and the "flash to pass" function on INT'L models.

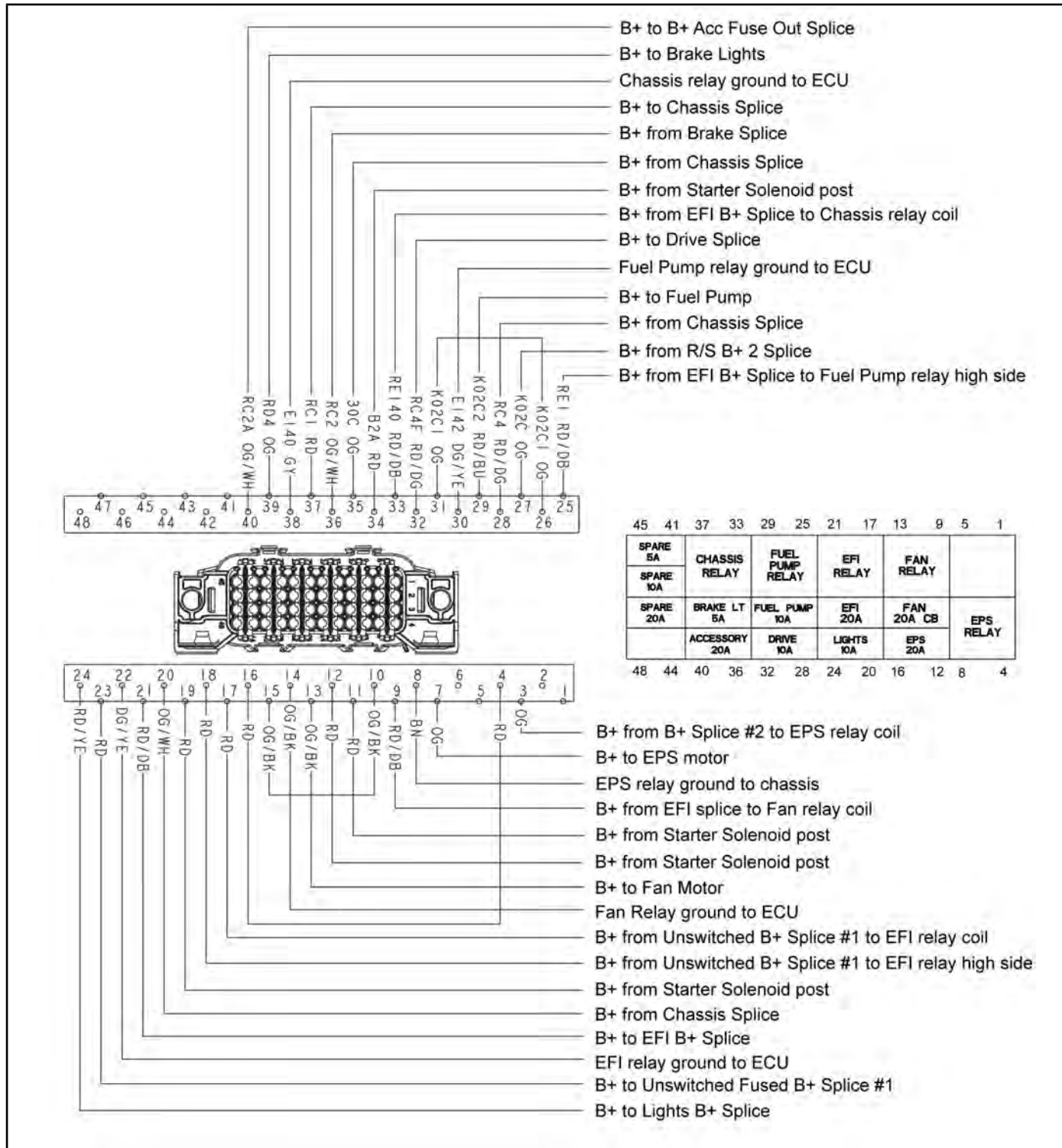

# ELECTRICAL

## Fuse Box Detail

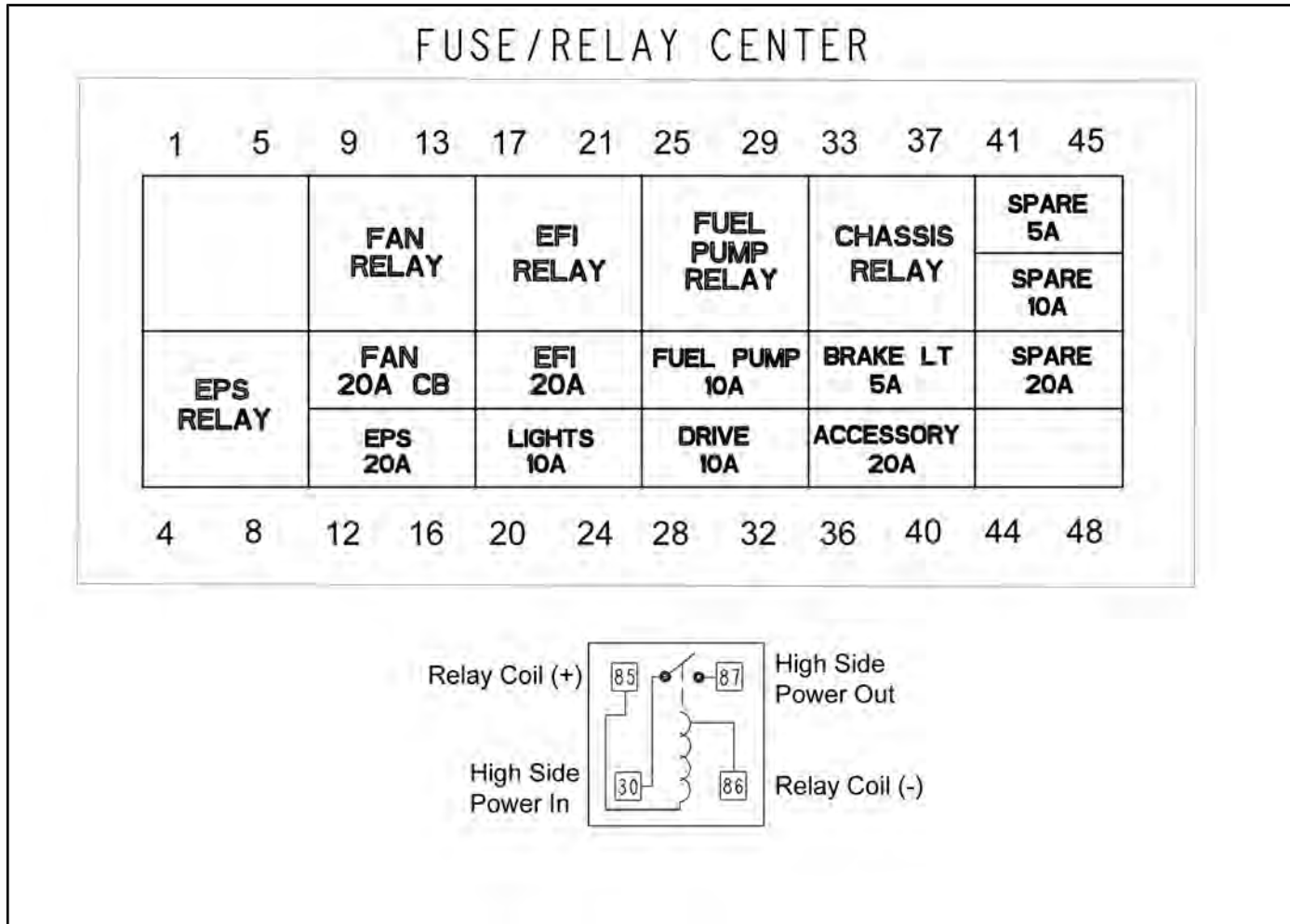

## Relay Operation

Located in the fuse box under the dash, the relays assist with component operation like the cooling fan, fuel pump and EFI system, drive system and EPS.

**NOTE: The Rear Diff Solenoid Relay (INT'L) is mounted separately, attached to the lower airbox bracket, accessed through the right rear wheel well.**

**The Headlight Relay (INT'L) and Flash to Pass Relay (INT'L) are also mounted separately, located under the dash.**

**CHASSIS RELAY** provides power to the following systems:

- Lights (Headlights / Taillights)
- Drive (AWD)
- Accessory (12V Receptacles / Accessory Options)

COLOR	FUNCTION
Red	30-Amp fuse protected 12 Vdc constant battery voltage.
Brown	Relay coil ground.
Orange	12 Vdc power input from key switch to enable relay.
White	Provides 12 Vdc power for lights, drive and accessory circuits.

**EFI RELAY** provides power to the following systems:

- Fuel Injectors
- Ignition Coil
- Fan Relay
- Fuel Pump Relay

COLOR	FUNCTION
Red / White	20-Amp fuse protected 12 Vdc constant battery voltage.
Dark Green / Yellow	ECU ground input to enable relay.
Red / White	20-Amp fuse protected 12 Vdc constant battery voltage.
Red / Dark Blue	Provides 12 Vdc power for EFI system circuits.

**FAN RELAY** provides power to the following system:

- Fan Motor

COLOR	FUNCTION
Red	20-Amp circuit breaker protected 12 Vdc constant battery power.
Orange / White	ECU ground input to enable relay.
Red / Dark Blue	12 Vdc switched power from EFI relay.
Orange / Black	Provides 12 Vdc power for fan operation.

**FUEL PUMP RELAY** provides power to the following system:

- Fuel Pump

COLOR	FUNCTION
Red / Green	10-Amp fuse protected 12 Vdc battery voltage.
Dark Green / Yellow	ECU ground input to enable relay.
Red / Dark Blue	12 Vdc switched power from EFI relay.
Red / Blue	Provides 12 Vdc power for fuel pump operation.

**EPS RELAY (OPT)** provides power to the following system:

- Electronic Power Steering Unit

COLOR	FUNCTION
Red	30-Amp fuse protected 12 Vdc constant battery voltage.
Brown	Relay coil ground.
Orange	12 Vdc power input from key switch to enable relay.
Orange	Provides 12 Vdc power for EPS operation.

**REAR DIFF SOLENOID RELAY (INT'L)** provides power to the following system:

- Rear Differential Solenoid

# ELECTRICAL

COLOR	FUNCTION
Red / Dark Green	10-Amp fuse protected 12 Vdc battery voltage.
Dark Green / White	ECU input to enable relay.
Brown	Relay coil ground.
Red	Relay switched power to operate the Rear Diff Solenoid.
Blue	Ground to energize the Rear Diff Solenoid.

**HEADLIGHT RELAY (INT'L)** provides power to the following system:

- Headlights

COLOR	FUNCTION
Red / Yellow	20-Amp fuse protected 12 Vdc battery voltage.
White / Red	Key switch input to enable relay.
Brown	Relay coil ground.
Yellow / Dark Green	Relay switched power to operate the Headlights.

**FLASH TO PASS RELAY (INT'L)** provides power to the following system:

- Momentary High Beam Headlight Operation

COLOR	FUNCTION
Dark Green	12 Vdc switched power from headlight relay used to operate low beam headlights during "normally closed" relay operation.
Brown	Relay coil ground.
Yellow	High beam input to "open" relay and disable low beam headlights in order to operate high beam headlights momentarily.
Dark Green	"Normally closed" relay output to operate low-beam headlights.

## CHARGING SYSTEM

### Current Draw - Key Off

#### CAUTION

Do not connect or disconnect the battery cable or ammeter with the engine running. Damage will occur to electrical components.

Connect an ammeter in series with the negative battery cable. Check for current draw with the key off. If the draw is excessive, loads should be disconnected from the system one by one until the draw is eliminated. Check component wiring as well as the component for partial shorts to ground to eliminate the draw.

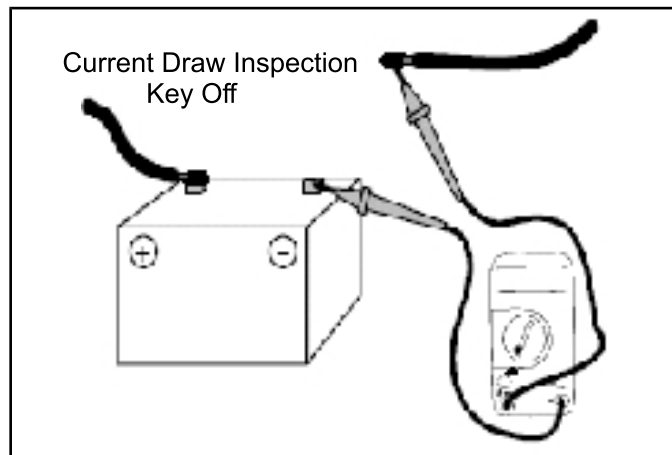

**Current Draw - Key Off:  
Maximum of .01 DCA (10 mA)**

### Charging System "Break Even" Test

#### CAUTION

Do not allow the battery cables to become disconnected with the engine running. Follow the steps below as outlined to reduce the chance of damage to electrical components.

The "break even" point of the charging system is the point at which the alternator overcomes all system loads (lights, etc.) and begins to charge the battery. Depending on battery condition and system load, the break even point may vary slightly. The battery should be fully charged before performing this test.

## WARNING

Never start the engine with an ammeter connected in series. Damage to the meter or meter fuse will result.  
Do not run test for extended period of time.  
Do not run test with high amperage accessories.

1. Using an inductive amperage metering device, (set to DC amps) connect to the negative battery cable.
2. With engine off, key switch and lights in the on position, the ammeter should read negative amps (battery discharge).
3. Shift transmission into park and start the engine. With the engine running at idle, observe meter readings.
4. Increase engine RPM while observing ammeter and tachometer. Note the RPM at which the battery starts to charge (ammeter indication is positive).
5. With lights and other electrical loads off, the "break even" point should occur at approximately 1500 RPM or lower.
6. With the engine running, turn the lights on and depress the brake pedal to keep brake lights on.
7. Repeat test, observing ammeter and tachometer. With lights on, charging should occur at or below 2000 RPM.

### Charging System Stator (Alternator) Tests

Three tests can be performed using a multi-meter to determine the condition of the stator (alternator).

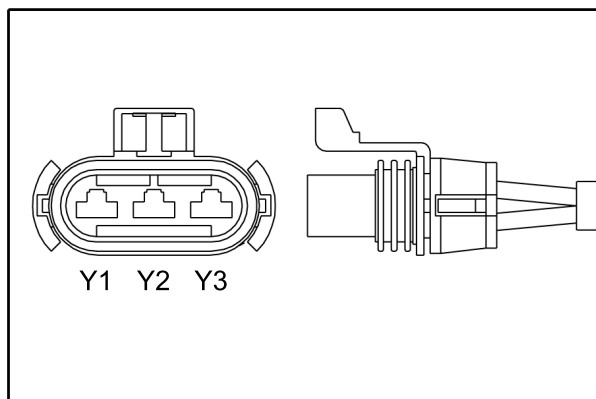

### TEST 1: Resistance Value of Each Stator Leg

1. Measure the resistance value of each of the three stator legs: Y1 to Y2, Y1 to Y3, and Y2 to Y3. Each test should measure: **0.07 - 0.13 Ω**

TEST	CONNECT METER LEADS TO:	OHMS READING
Battery Charge Coil	Y1 to Y2	0.07 - 0.13 Ω
Battery Charge Coil	Y1 to Y3	0.07 - 0.13 Ω
Battery Charge Coil	Y2 to Y3	0.07 - 0.13 Ω

**NOTE: If there are any significant variations in ohm readings between the three legs it is an indication that one of the stator legs may be weak or failed.**

### TEST 2: Resistance Value of Each Stator Leg to Ground

2. Measure the resistance value of each of the stator legs to ground: Y1 to Ground, Y2 to Ground, Y3 to Ground.
3. Each test should measure: **Open Line (OL)**

TEST	CONNECT METER LEADS TO:	OHMS READING
Battery Charge Coil	Y1, Y2, or Y3 to Ground	Open Line (Infinity)

**NOTE: Any measurement other than Infinity (open) will indicate a failed or shorted stator leg.**

### TEST 3: Measure AC Voltage Output of Each Stator Leg at Charging RPM

4. Set the selector dial to measure AC Voltage.
5. Start the engine and let it idle.
6. While holding the engine at a specified RPM, separately measure the voltage across each 'leg' of the stator by connecting the meter leads to the wires leading from the alternator (Y1 to Y2, Y1 to Y3, Y2 to Y3).
7. Refer to the following table for approximate AC Voltage readings according to RPM. Test each leg at the specified RPM in the table.

**10**

# ELECTRICAL

8. Example: The alternator current output reading should be approximately 21 VAC at 1300 RPM between each 'leg'.

**NOTE:** If one or more of the stator leg output AC voltage varies significantly from the specified value, the stator may need to be replaced.

RPM READING	AC VOLTAGE (VAC) READING
1300	21 VAC ± 25%
3000	47 VAC ± 25%
5000	79 VAC ± 25%

## Stator (Alternator) Replacement

Refer to Engine Chapter "Stator Cover Removal / Inspection" procedure to service the stator.

**NOTE:** The stator cover can be removed with the engine installed in the chassis.

Be sure to thoroughly clean the area around the stator cover prior to removal.

## Regulator / Rectifier

The regulator / rectifier (Item 1) is located in the left rear wheel well area in front of the left rear shock. It is mounted under the LH panel divider.

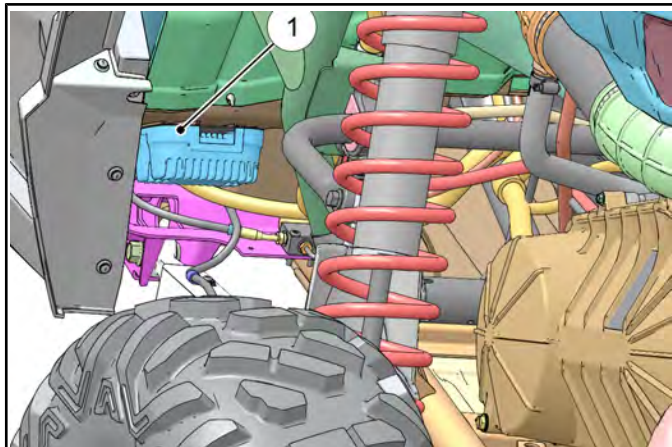

**NOTE:** If the regulator / rectifier case temperature exceeds 230° F or 110° C, the unit will turn itself off to cool down. The unit will turn on again after it has cooled down to at least 212° F or 100° C. If it turns off, verify the cooling fins are clean, free from debris and that adequate airflow is present.

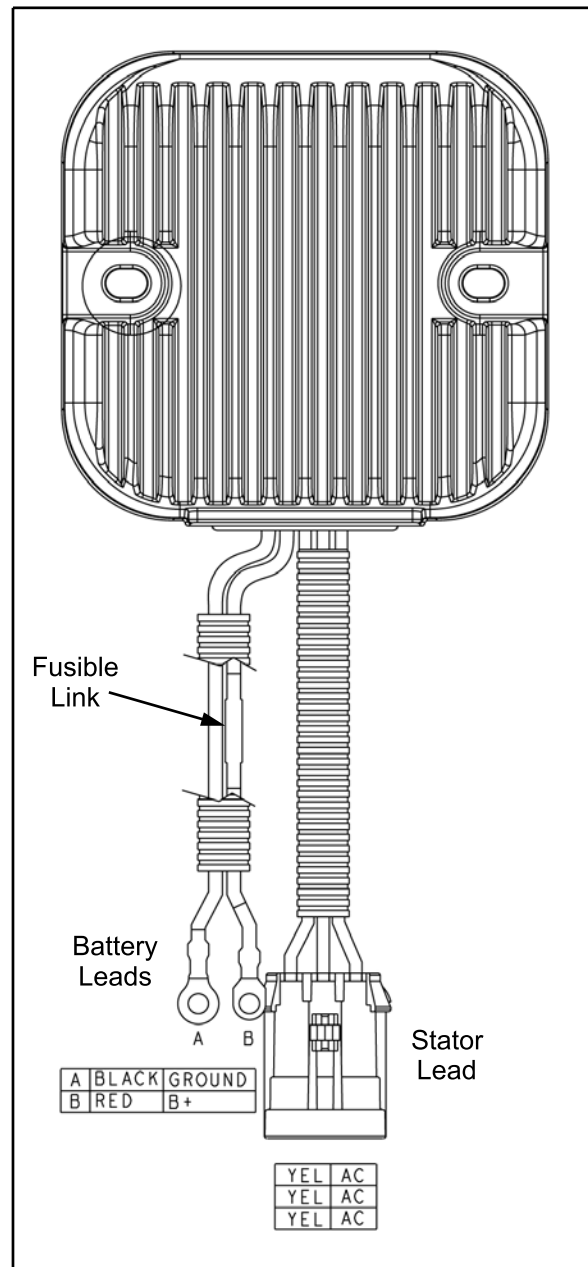

## Charging System Testing Flow Chart

Whenever charging system problems are suspected, proceed with the following system check after verifying that all wires are in good condition, connected and not exposed or pinched.

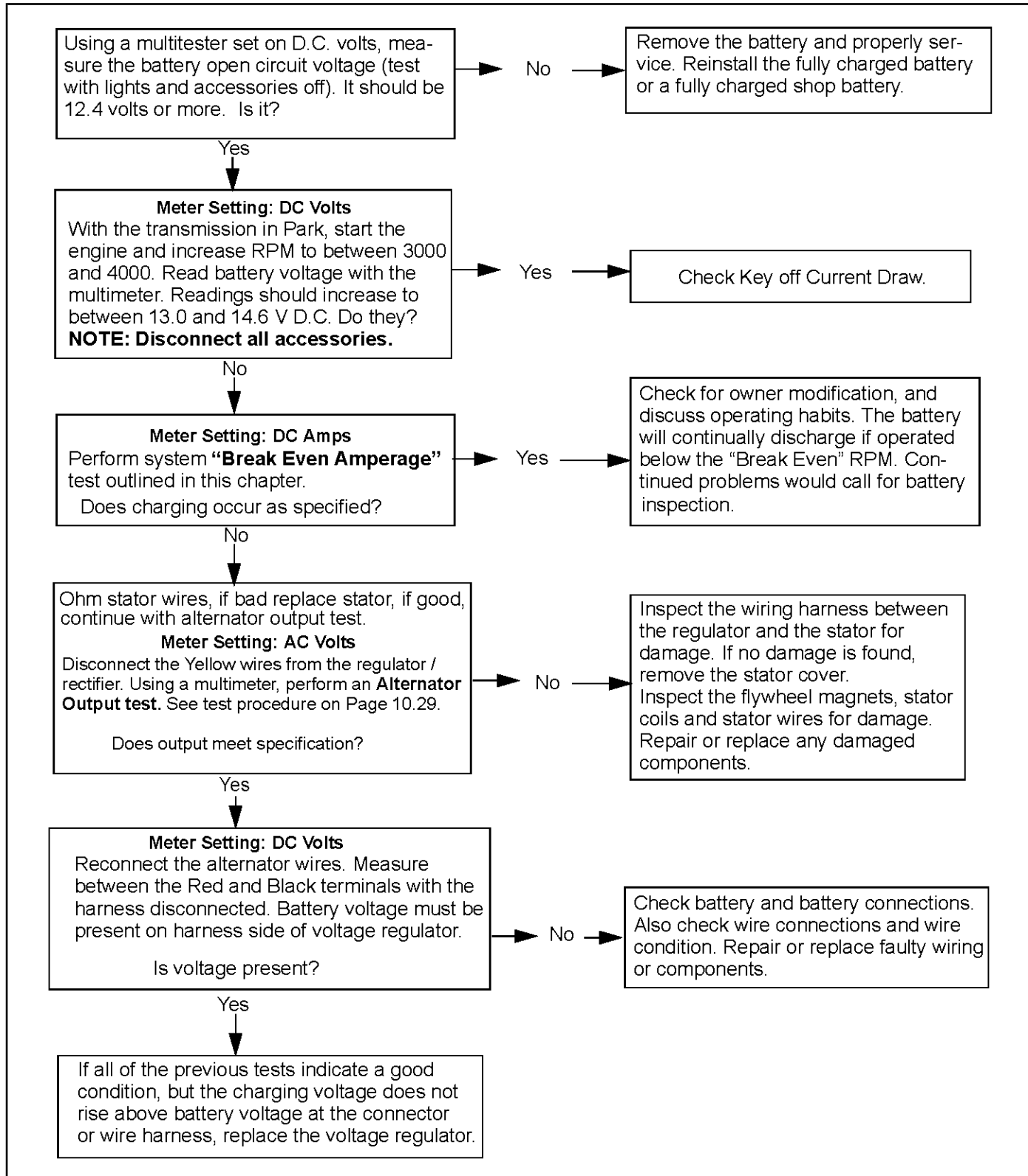



# ELECTRICAL

## BATTERY SERVICE

### Battery Specifications

Type	Polaris / Johnson Controls 575 Sealed - Maintenance Free
Voltage	12 Vdc
Nominal Capacity @ 10 HR Rate	30 AH
CCA	575
Nominal Open Circuit Voltage	12.8 Vdc or more.
Recommended Charging Rate	1.8A @ 5-10 HR or 6.0A @ 1 HR

**NOTE: Never attempt to open the battery. If the seal is broken, the battery will be ruined and will fail within a few weeks.**

### General Battery Information

 <b>WARNING</b>
CALIFORNIA PROPOSITION 65 WARNING: Batteries, battery posts, terminals and related accessories contain lead and lead compounds, and other chemicals known to the State of California to cause cancer and birth defects or other reproductive harm. WASH HANDS AFTER HANDLING.

 <b>WARNING</b>
Battery electrolyte is poisonous. It contains acid! Serious burns can result from contact with the skin, eyes, or clothing.
<b>ANTIDOTE:</b> External: Flush with water.
Internal: Drink large quantities of water or milk. Follow with milk of magnesia, beaten egg, or vegetable oil. Call a physician immediately.
Eyes: Flush with water for 15 minutes and get prompt medical attention.
Batteries produce explosive gases. Keep sparks, flame, cigarettes, etc. away. Ventilate when charging or using in closed space. Always shield eyes when working near batteries.
Keep out of reach of children.

1. Check battery voltage with a volt/ohm meter. A fully charged battery should be 12.8 V or higher.
2. If the voltage is below 12.6 V, the battery will need to be recharged (see "Charging Procedure").

**To service a Maintenance Free battery:**

3. Remove battery from the vehicle (see Chapter 2).
4. Test battery with a voltage meter or load tester to determine battery condition. This will determine the length of time required to charge the battery to full capacity. Refer to OCV table (see "OCV - Open Circuit Voltage Test").
5. Charge the battery as recommended (see "Charging Procedure").

## Battery Removal / Installation

See Chapter 2 “Maintenance” for battery removal and installation procedures.

## Battery Off Season Storage

Whenever vehicle is not used for a period of three months or more, remove the battery from the vehicle, ensure that it's fully charged, and store it out of the sun in a cool, dry place. Check battery voltage each month during storage and recharge as needed to maintain a full charge.

**NOTE: Battery charge can be maintained by using a Polaris battery tender charger or by charging once a month to make up for normal self-discharge. Battery tenders can be left connected during the storage period, and will automatically charge the battery if the voltage drops below a pre-determined point.**

## Battery Testing

Whenever a service complaint is related to either the starting or charging systems, the battery should be checked first.

The following are two tests which can easily be made on a sealed Maintenance Free battery to determine its condition: OCV Test and a Load Test.

### OCV - Open Circuit Voltage Test

Battery voltage should be checked with a digital multimeter. Readings of 12.6 volts or less require further battery testing and charging. See the following chart and “Load Test”.

**NOTE: Maintenance Free batteries should be kept at a high state of charge during storage. If the battery is stored or used at a low state of charge, hard crystal sulfation will form on the plates, reducing the efficiency and service life of the battery.**

Use a volt/ohm meter to test battery voltage.

### OPEN CIRCUIT VOLTAGE

STATE OF CHARGE	VOLTAGE
100%	12.8 V and up
75% Charged	12.6 V
50% Charged	12.3 V
25% Charged	12.0 V
0% Charged	11.8 V or less

## Load Test

### CAUTION

To prevent shock or component damage, remove spark plug high tension leads and connect securely to engine ground before proceeding.

A battery may indicate a full charge condition in the OCV test, but still may not have the storage capacity necessary to properly function in the electrical system. For this reason, a battery capacity or load test should be conducted whenever poor battery performance is encountered.

To perform this test, use a load testing device that has an adjustable load. Apply a load of three times the ampere-hour rating. At 14 seconds into the test, check battery voltage. A good 12V battery will have at least 10.5 volts. If the reading is low, charge the battery and retest.

## Battery Conductance Analyzer

Conductance describes the ability of a battery to conduct current. A conductance tester functions by sending a low frequency AC signal through the battery and a portion of the current response is captured, from this output a conductance measurement is calculated. Conductance testing is more accurate than voltage, specific gravity, or load testing.

Authorized Polaris dealers/distributors are required to use the conductance analyzer when testing 12V Polaris batteries.



Polaris MDX-610P  
Conductance Analyzer

Polaris MDX-610P  
Bosch PN: PU-50296

# ELECTRICAL

## Charging Procedure

If battery voltage is 12.6 Vdc or less, the battery may need recharging. When using an automatic charger, refer to the charger manufacturer's instructions for recharging.

Do not exceed 6 amps when charging the 4011224 battery.

**NOTE: Charge the battery using an automatic charger that will not exceed 14.6 Vdc. An automatic charger will signal when charging is complete.**

**Allow the battery to stand disconnected for at least 1-2 hours after being properly charged. If the voltage drops below 12.6 volts, charging was ineffective or the battery needs to be replaced.**



### WARNING

An overheated battery could explode, causing severe injury or death. Always watch charging times carefully. Stop charging if the battery becomes very warm to the touch. Allow it to cool before resuming charging.

STATE OF CHARGE	VOLTAGE (DC)	ACTION	CHARGE TIME
100%	12.8 or more	None, check again in 3 months	None Required
75% - 100%	12.6 - 12.8	May need slight charge	3 - 6 hrs
50% - 75%	12.3 - 12.6	Needs Charge	5 - 11 hrs
25% - 50%	12.0 - 12.3	Needs Charge	At least 13 hrs
0% - 25%	12.0 or less	Needs Charge	At least 20 hrs

**NOTE: Follow the charger instructions supplied by the manufacture regarding the order or connections, switch positions and when to connect the charger to an outlet.**

## STARTING SYSTEM

### Troubleshooting

#### Starter Motor Does Not Run

- Battery discharged
- Loose or faulty battery cables or corroded connections (see Voltage Drop Tests)
- Related wiring loose, disconnected, or corroded
- Poor ground connections at battery cable, starter motor or starter solenoid (see Voltage Drop Tests)
- Faulty key switch
- Faulty starter solenoid or starter motor
- Engine problem - seized or binding (can engine be rotated easily)

#### Starter Motor Turns Over Slowly

- Battery discharged
- Excessive circuit resistance - poor connections (see Voltage Drop Test)
- Engine problem - seized or binding (can engine be rotated easily)
- Faulty or worn brushes in starter motor

#### Starter Motor Turns - Engine Does Not Rotate

- Faulty starter drive
- Faulty starter drive gears or starter motor gear
- Faulty flywheel gear or loose flywheel

### Voltage Drop Test

The Voltage Drop Test is used to test for bad connections. When performing the test, you are testing the amount of voltage drop through the connection. A poor or corroded connection will appear as a high voltage reading. Voltage shown on the meter when testing connections should not exceed 0.1 VDC per connection or component.

To perform the test, place the meter on DC volts and place the meter leads across the connection to be tested. Refer to the voltage drop tests on the starter system in this chapter.

**Voltage should not exceed 0.1 DC volts per connection**

## Starter Motor Removal

1. Remove driver side seat and disconnect the battery.
2. Raise and support rear of vehicle.
3. Remove the RH rear wheel.
4. Remove (+) positive wire from starter motor terminal.
5. From the RH side wheel well using an 8mm flex socket, remove the negative battery cable nut and the (2) fasteners securing the starter motor to the engine.

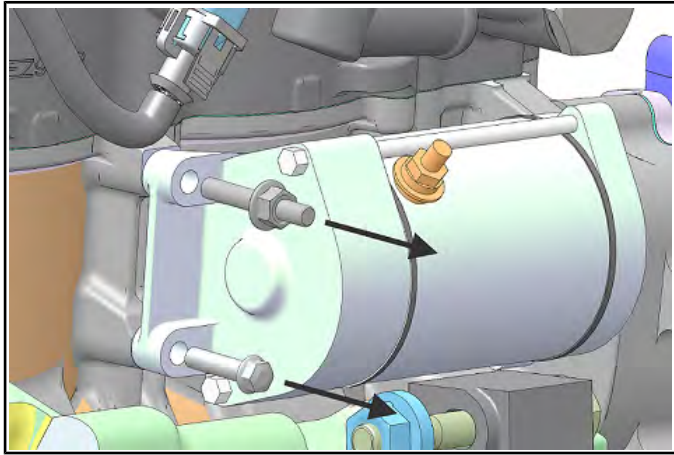

**NOTE:** The (-) negative battery cable is mounted to the engine using the upper starter mounting bolt / stud.

6. Remove the starter from the engine.

## Starter Motor Installation

1. Inspect and replace starter motor O-ring if needed.
2. Lubricate starter motor O-ring with fresh engine oil.
3. Install the starter motor onto the engine case.
4. Hand tighten the upper starter mounting bolt / stud.
5. Install and torque the lower mounting bolt to specification.

**NOTE:** Tighten the lower starter bolt first, as the bottom hole acts as a pilot hole to properly align the starter drive (bendix) with the flywheel. This helps prevent binding and starter damage.

6. Torque upper starter mounting screw to specification.

7. Install (-) negative battery cable to the upper starter mounting bolt / stud. Torque nut to specification.



Starter Mounting Bolts and Nut:  
**7 ft-lb (10 Nm)**

## Starter Solenoid Bench Test

Test the start solenoid by powering the solenoid using battery voltage for a *maximum of 5 seconds*. With the solenoid energized, resistance should read about 0 - 0.5 ohms between terminals (A) and (B). If resistance measurement is out of specification, replace the starter solenoid.

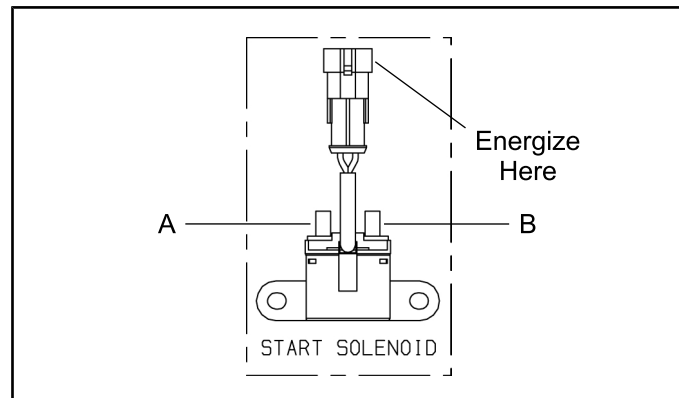

## Starter Solenoid Operation

To energize the Starter Solenoid the following must occur:

- The brake must be applied to provide a ground path via the Orange wire.
- The key switch must be turned to the “start” position to provide 12V power via the Green / White wire.
- Once the pull-in coil is energized, the solenoid provides a current path for 12V power to reach the starter motor.

**NOTE:** See “ELECTRICAL SYSTEM BREAOUTS: Starter-Interlock” provided in this chapter for starter solenoid operation.

# ELECTRICAL

## STARTING SYSTEM TESTING FLOW CHART

Condition: Starter fails to turn over the engine.

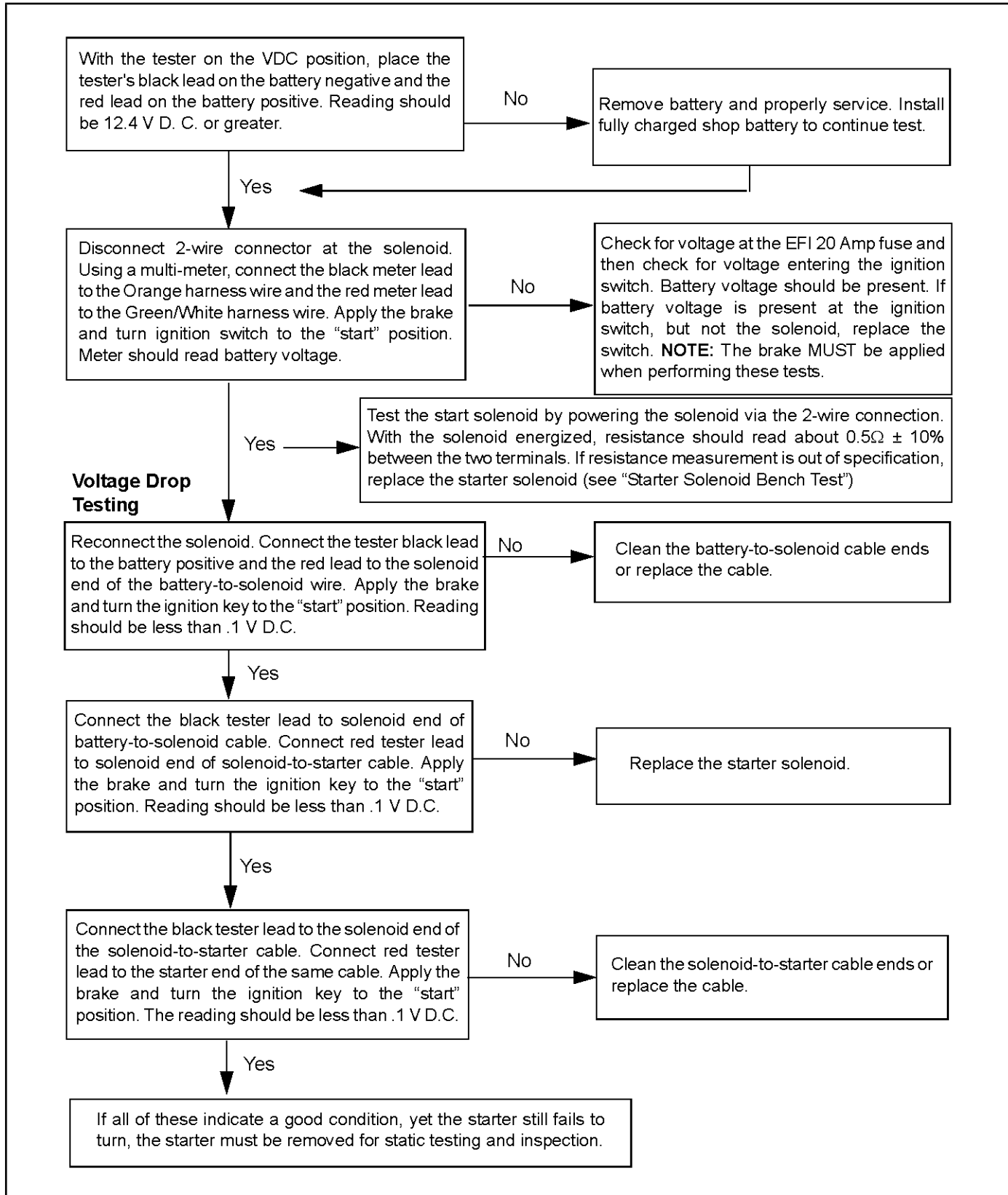

## ELECTRONIC POWER STEERING (EPS)

### EPS Operation

The EPS module is an intelligent electronic power steering system that operates off of the vehicle's 12V electrical system. It calculates steering assist by sensing the difference between the input torque of the steering post and the output torque required to turn the wheels, and then provides assist by energizing an electric motor. The process provides a smooth, seamless assist.

The system is continuously running diagnostic checks and monitoring factors such as battery voltage, ground speed and engine speed. In the event an internal or external issue that affects the EPS system is detected, the system will illuminate a fault indicator and transition to a normal mechanically coupled steering system. The system is Polaris Digital Wrench® compatible for simplified diagnostics and system troubleshooting through the vehicle's diagnostic port.

With the engine off and the key on, the power steering unit will operate for up to five minutes. After the five minutes, you will need to cycle the key switch and restart the engine to regain power steering operation.

**NOTE: To conserve battery power, the EPS unit will shut down 5 minutes after the engine has stopped if the key remains in the ON position. At this point, the EPS Malfunction Indicator Light will illuminate to indicate the EPS has shut down and will set a fault code in Digital Wrench®.**

### The Power Steering 30A Fuse.

- If the fuse fails, the Power Steering Malfunction Indicator Light (MIL) on the instrument cluster will illuminate. During this time, the vehicle will have no power steering operation. You will be able to connect and communicate with the vehicle's Engine Controller, but not the Power Steering Controller, while using Digital Wrench®.

**NOTE: DO NOT SPLICE OR CUT INTO THE CAN CIRCUITS.**



### WARNING

Electronic Power Steering (EPS) units are not interchangeable between ATV and *RANGER* product lines.

**NOTE: See Chapter 5 ELECTRONIC POWER STEERING ASSEMBLY, page 5.30 for power steering unit removal and installation procedures.**

WIRE COLOR	FUNCTION
ORANGE (2-Pin)	Main Power (30A Protected)
BROWN (2-Pin)	Ground
ORANGE (8-Pin)	Key-On Battery Voltage
YELLOW (8-Pin)	CAN High Signal
GREEN (8-Pin)	CAN Low Signal

### Proper EPS System Diagnosing

**READ BEFORE YOU REPLACE THE EPS UNIT!**

**NOTE: Verify the EPS unit has the latest software version and calibration loaded before replacing the EPS unit. If not, update to the latest version for each and follow the guided diagnostic procedure (s) available in Digital Wrench®.**

# ELECTRICAL

## EPS System Breakout

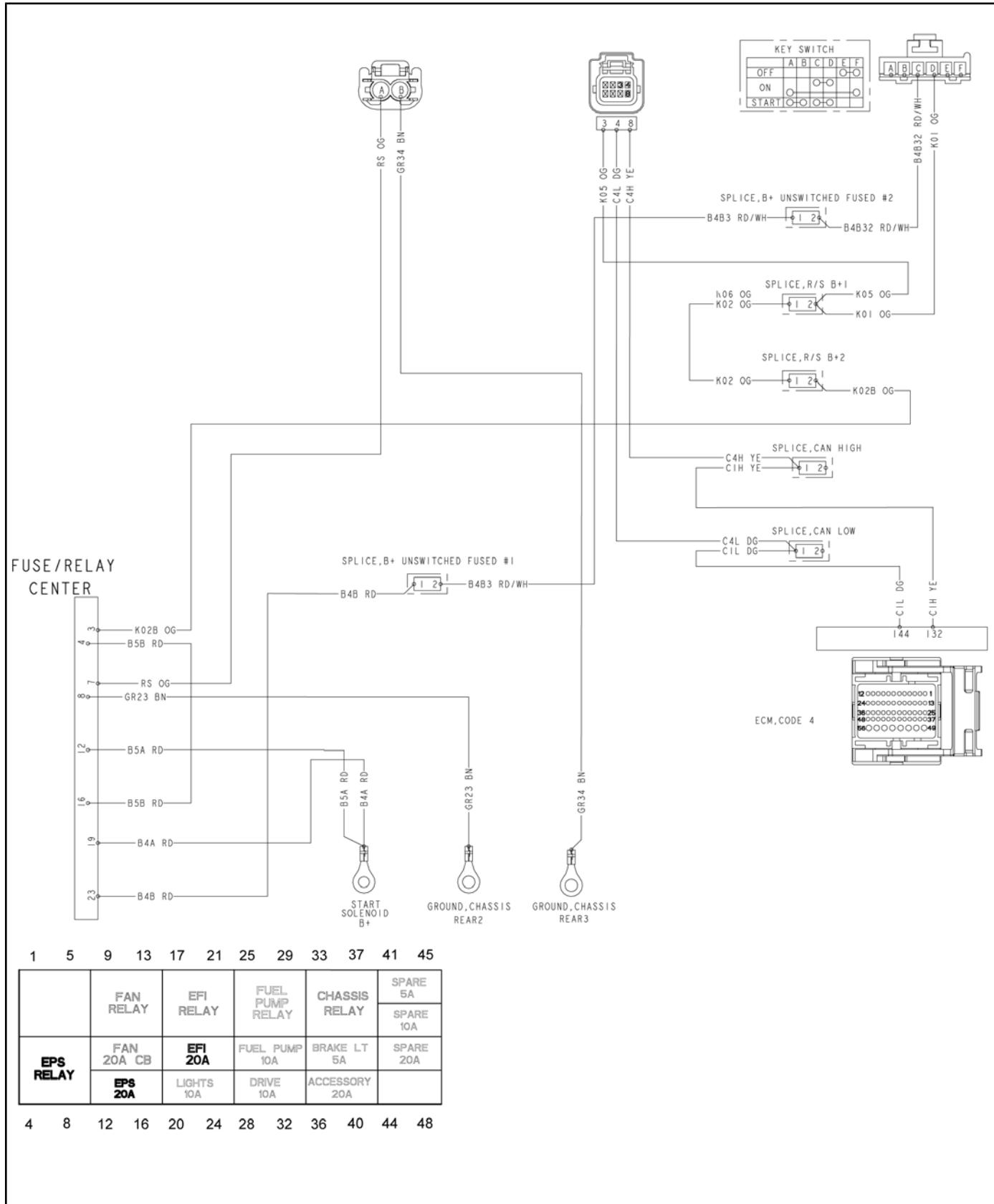

EPS Troubleshooting (Power Steering Non-Functional with MIL ON)

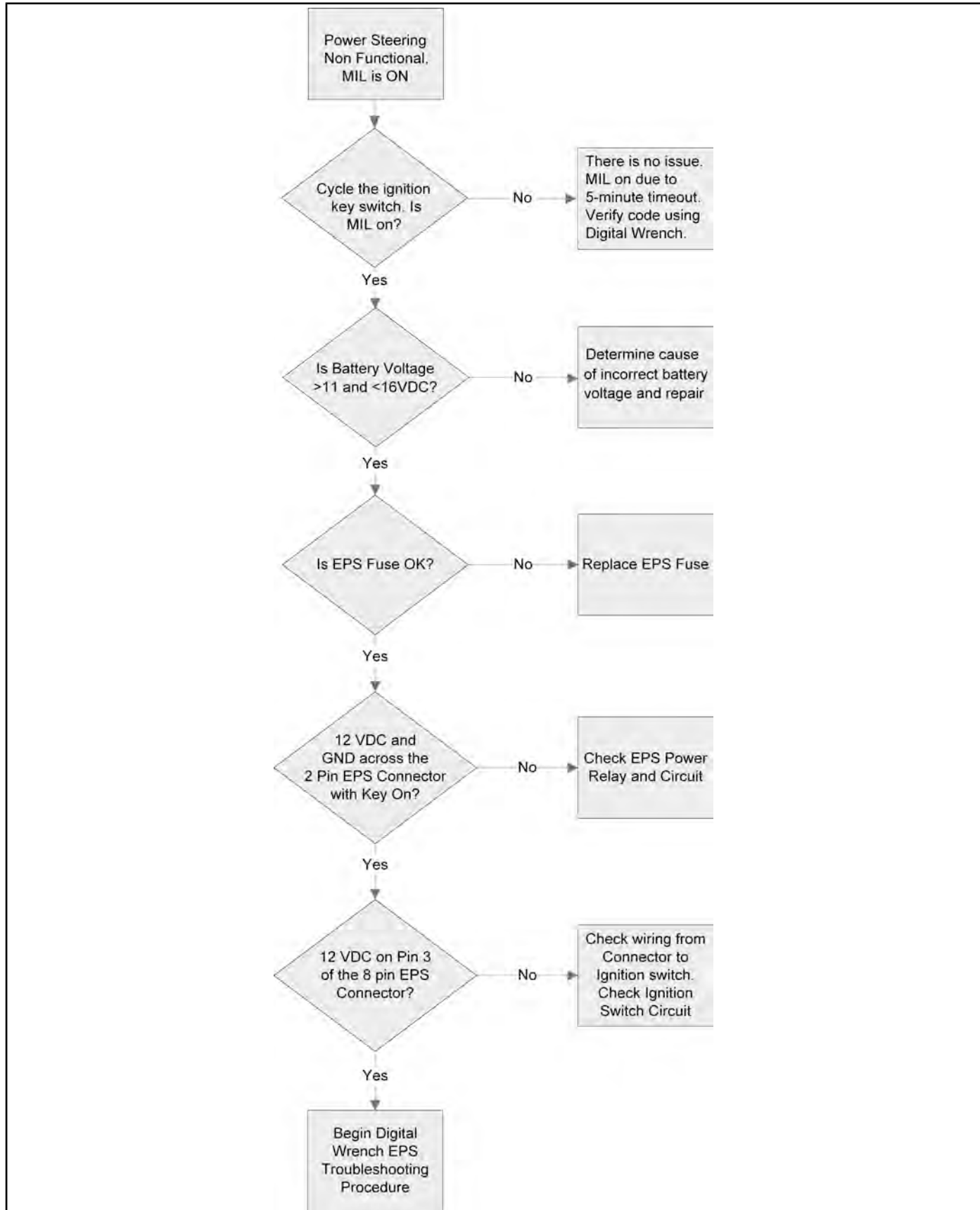



# ELECTRICAL

## EPS Troubleshooting (Power Steering Non-Functional with MIL OFF)

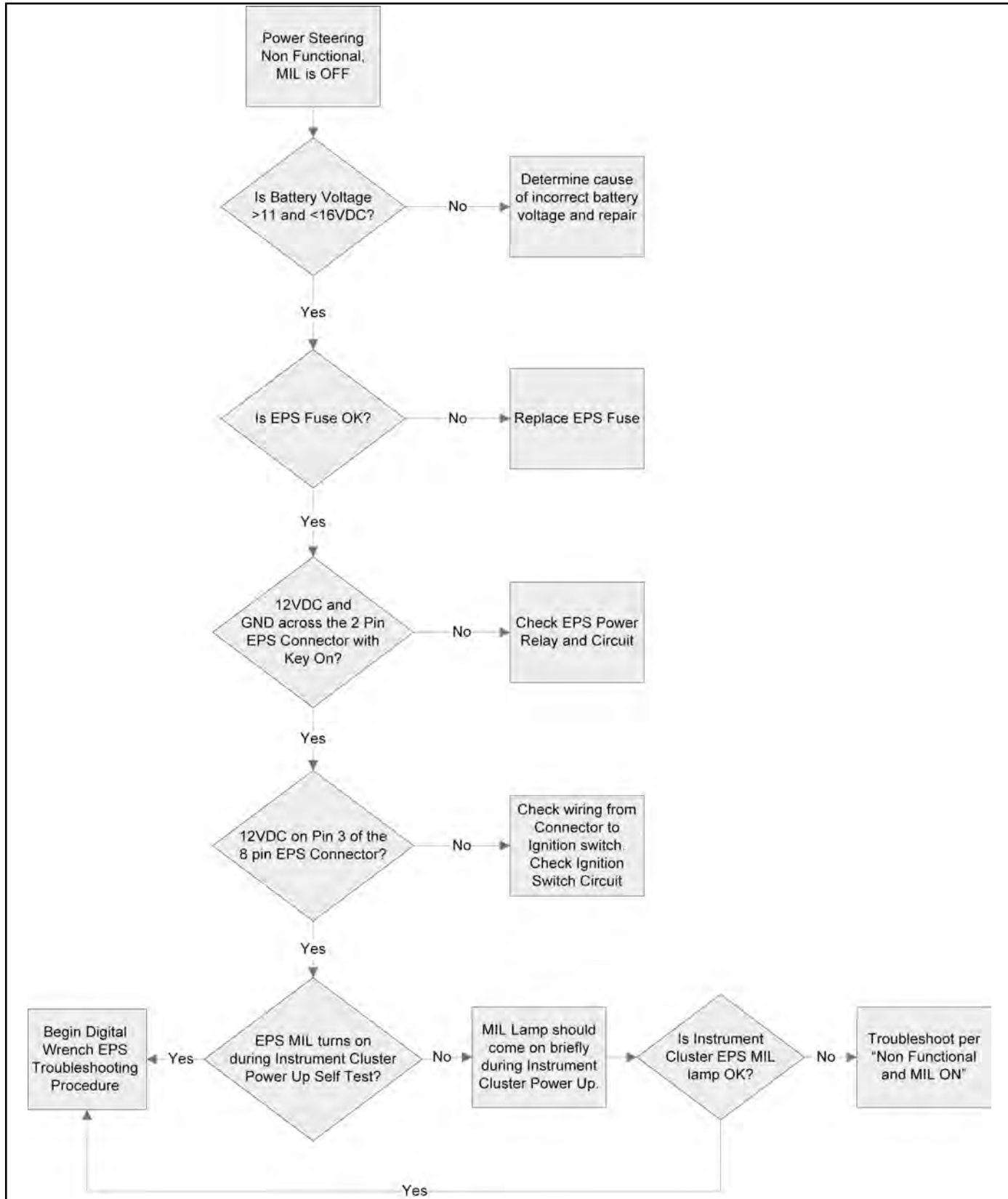

## EPS Troubleshooting (Using Digital Wrench®)

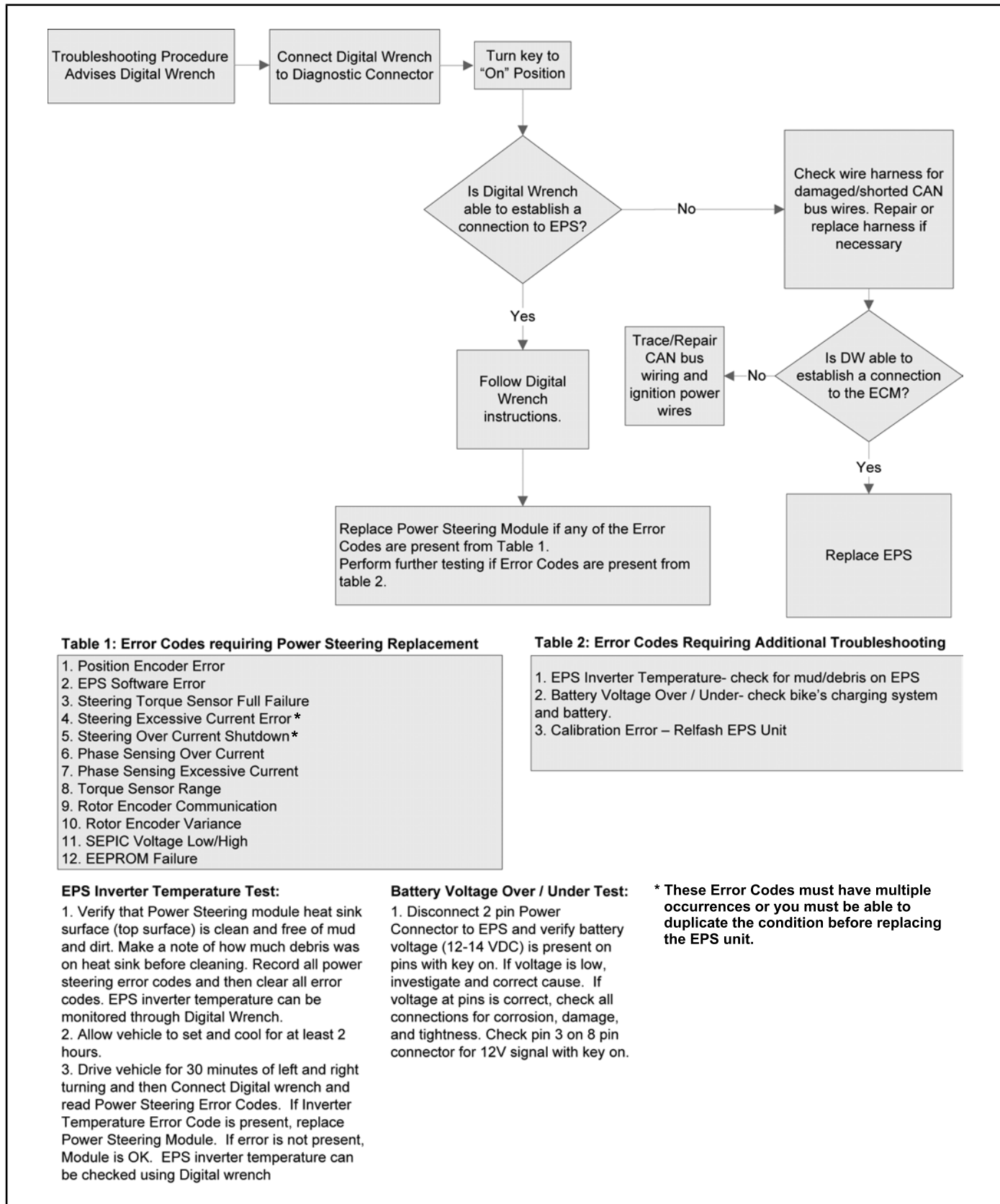

**Table 1: Error Codes requiring Power Steering Replacement**

1. Position Encoder Error
2. EPS Software Error
3. Steering Torque Sensor Full Failure
4. Steering Excessive Current Error \*
5. Steering Over Current Shutdown \*
6. Phase Sensing Over Current
7. Phase Sensing Excessive Current
8. Torque Sensor Range
9. Rotor Encoder Communication
10. Rotor Encoder Variance
11. SEPIC Voltage Low/High
12. EEPROM Failure

**Table 2: Error Codes Requiring Additional Troubleshooting**

1. EPS Inverter Temperature- check for mud/debris on EPS
2. Battery Voltage Over / Under- check bike's charging system and battery.
3. Calibration Error – Relfash EPS Unit

**EPS Inverter Temperature Test:**

1. Verify that Power Steering module heat sink surface (top surface) is clean and free of mud and dirt. Make a note of how much debris was on heat sink before cleaning. Record all power steering error codes and then clear all error codes. EPS inverter temperature can be monitored through Digital Wrench.
2. Allow vehicle to set and cool for at least 2 hours.
3. Drive vehicle for 30 minutes of left and right turning and then Connect Digital wrench and read Power Steering Error Codes. If Inverter Temperature Error Code is present, replace Power Steering Module. If error is not present, Module is OK. EPS inverter temperature can be checked using Digital wrench

**Battery Voltage Over / Under Test:**

1. Disconnect 2 pin Power Connector to EPS and verify battery voltage (12-14 VDC) is present on pins with key on. If voltage is low, investigate and correct cause. If voltage at pins is correct, check all connections for corrosion, damage, and tightness. Check pin 3 on 8 pin connector for 12V signal with key on.

\* These Error Codes must have multiple occurrences or you must be able to duplicate the condition before replacing the EPS unit.



Vehicle Speed Sensor

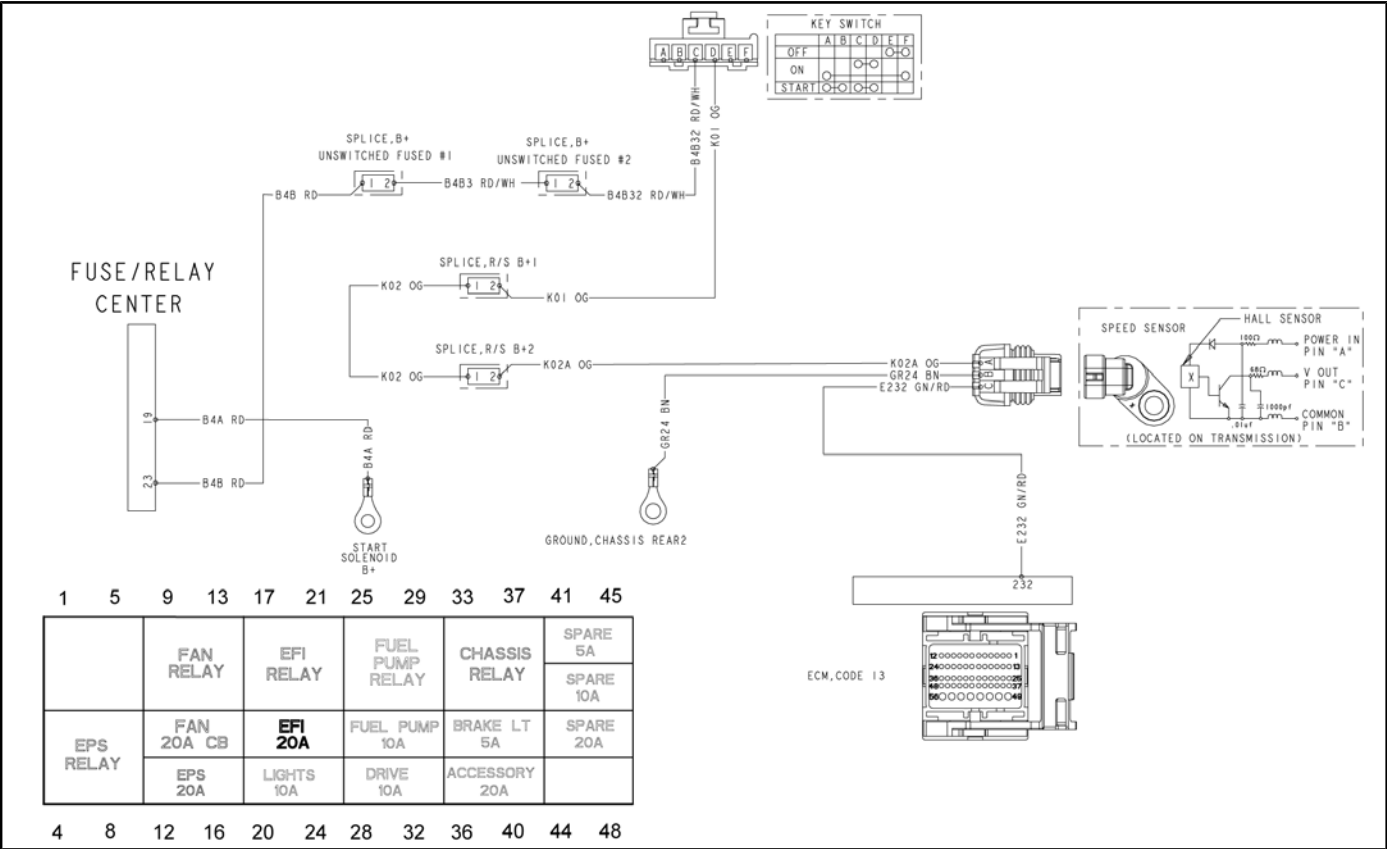

# ELECTRICAL

## Cooling System

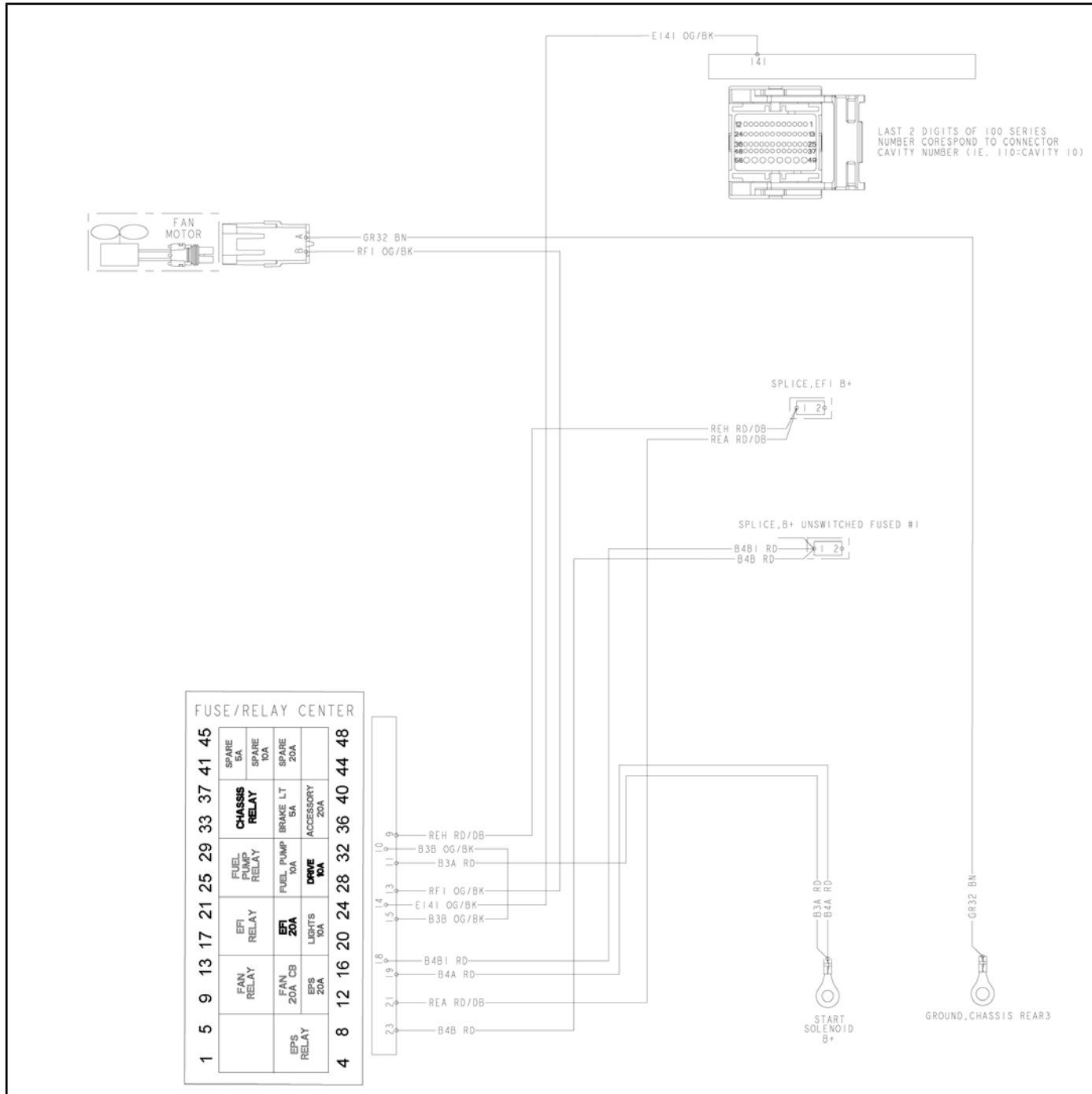

**Unswitched Chassis Power**

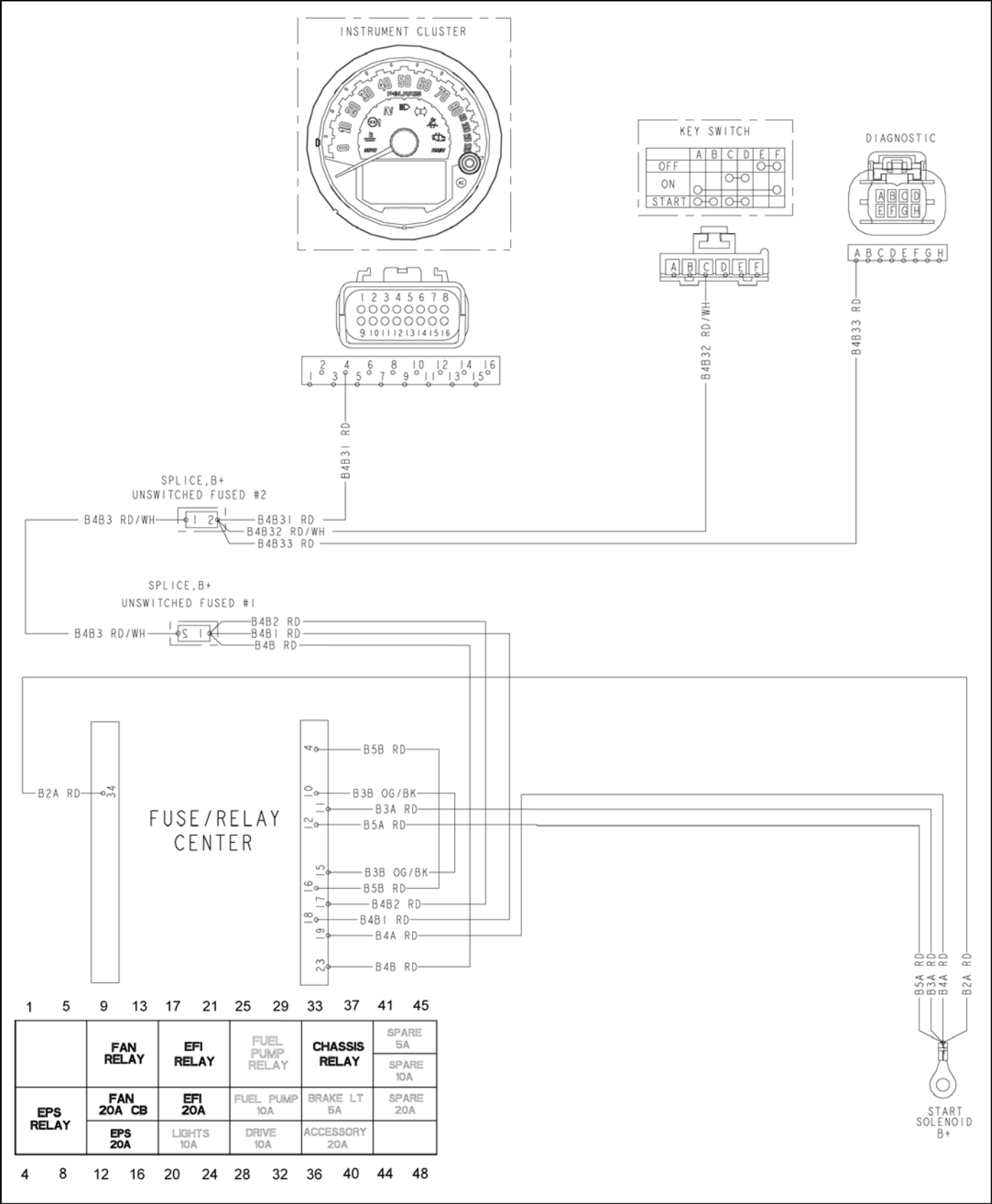

**10**



## Lights

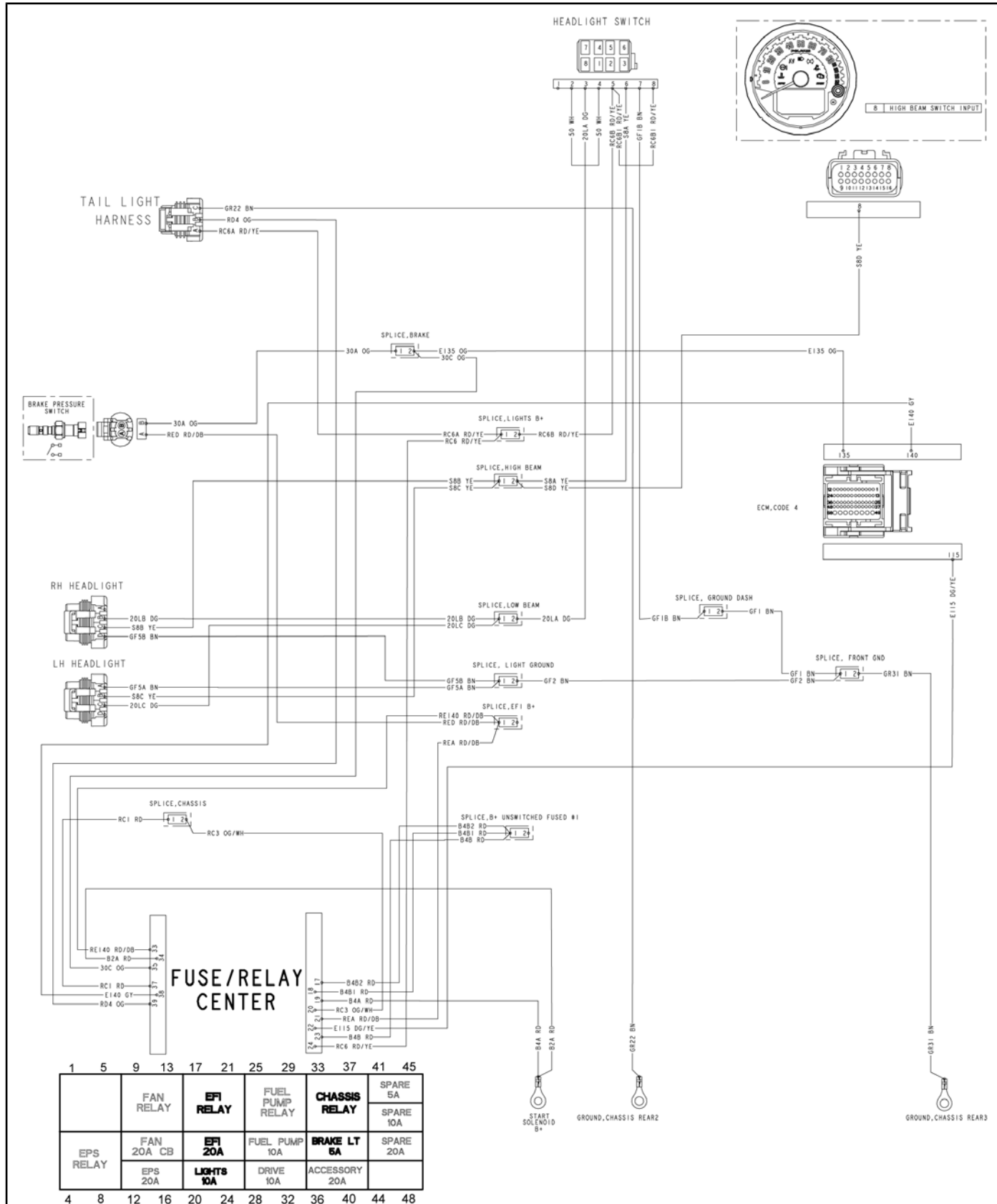

10



# ELECTRICAL

## Charging System

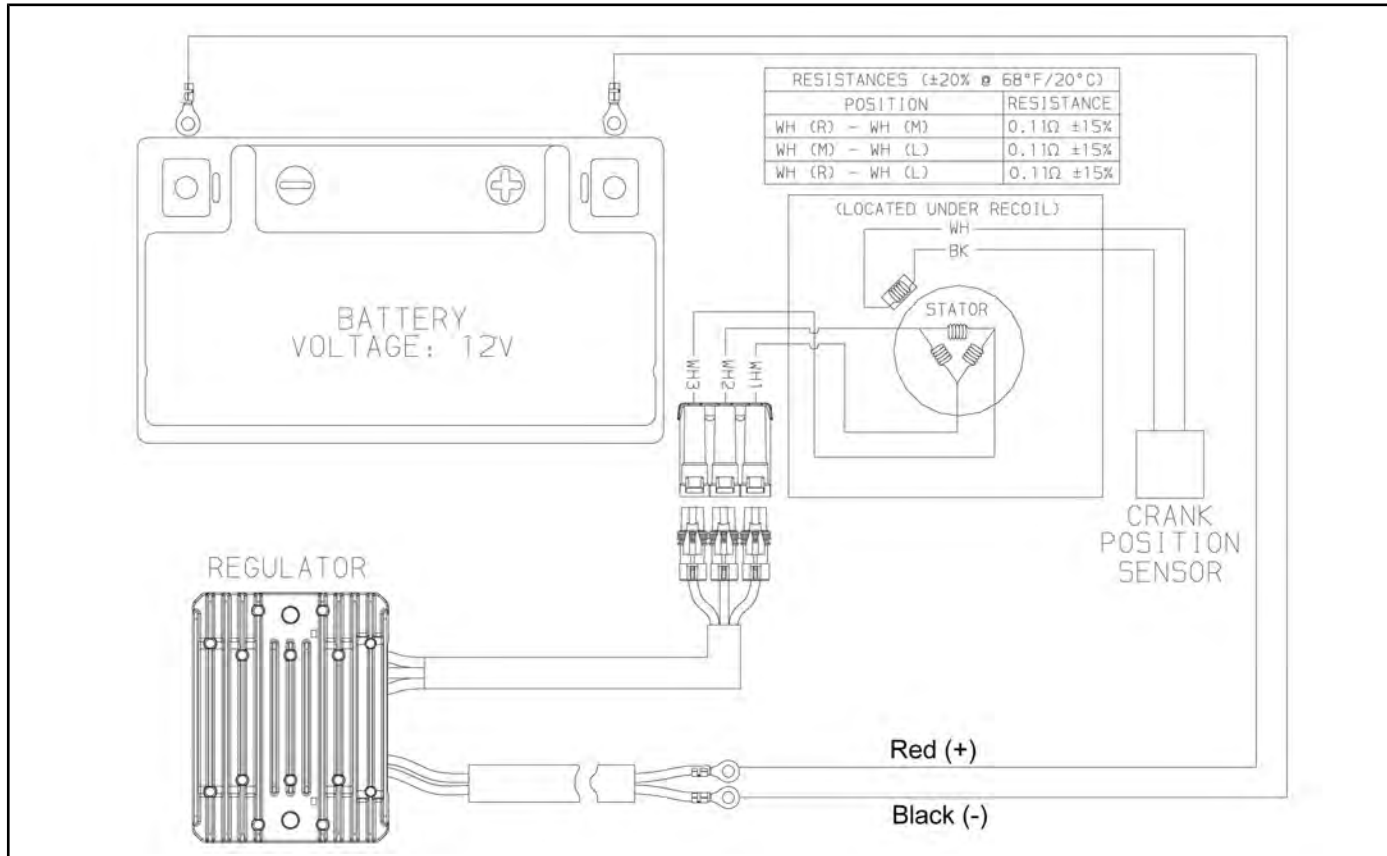

**A**

- Air Box
  - Assembly View..... 2.15
- Air Filter
  - Assembly View..... 2.15
  - Pre-Filter Service ..... 2.13
  - Service..... 2.13
- Air Intake Duct Drain ..... 2.14
- Alignment
  - Wheel..... 2.33
- Authorization
  - Reflash..... 4.45
- AWD
  - Diagnosis ..... 7.17
  - Operation ..... 7.17
- AWD Coil ..... 10.19
- AWD/2WD Switch..... 10.15

- Thickness ..... 9.18
- Brake Pad Inspection ..... 2.37
- Brake Pads
  - Rear ..... 9.26
  - Removal (Front) ..... 9.17
- Brake Pedal
  - Installation ..... 9.9
  - Removal ..... 9.9
- Brake System
  - Assembly View..... 9.7
  - Bleeding ..... 9.9
  - Operation ..... 9.4
  - Troubleshooting ..... 9.35
- Brakes
  - Torque Specifications ..... 9.3
- Break Even Test ..... 10.30
- Break-In Period ..... 2.3

**B**

- Balance Shaft
  - Installation ..... 3.67
  - Removal / Inspection ..... 3.49
- Ball Joint
  - Service ..... 5.39
- Battery
  - Installation ..... 2.30
  - Load Test..... 10.35
  - Maintenance ..... 2.29
  - Removal ..... 2.30
  - Service ..... 10.34
  - Storage ..... 10.35
  - Tester ..... 10.35
  - Testing ..... 10.35
- Battery Charging Procedure ..... 10.36
- Bearing Carrier
  - Front ..... 7.3
  - Rear Service ..... 7.26
- Belt Inspection..... 6.11
- Belt Installation ..... 6.11
- Belt Removal..... 6.10
- Bleeding
  - Cooling System..... 3.18
- Brake Burnishing ..... 9.19, 9.29
- Brake Caliper
  - Assembly (Front)..... 9.23
  - Assembly View (Front)..... 9.20
  - Inspection (Front)..... 9.22
  - Installation (Front) ..... 9.23
  - Rear..... 9.30
  - Removal (Front)..... 9.20
- Brake Disc
  - Front ..... 9.24
  - Rear..... 9.34
- Brake Fluid Inspection..... 2.37
- Brake Hose and Fitting Inspection..... 2.37
- Brake Light Switch ..... 10.13
- Brake Pad
  - Installation (Front) ..... 9.19

**C**

- Cab Frame
  - Assembly / Removal ..... 5.5–5.6
- Camshaft
  - Installation / Timing..... 3.76
  - Removal ..... 3.33
  - Sprocket Inspection ..... 3.34
- Camshaft Timing - Quick Reference ..... 3.80
- Cargo Box
  - Removal ..... 5.21
- Centralized Hilliard
  - Assembly View..... 7.16
- Charging System ..... 10.30
  - Stator Tests ..... 10.31
  - Testing Flow Chart..... 10.33
- Chassis ..... 5.11–5.12
- Clutch
  - Starter One Way ..... 3.72
- Clutch Chart ..... 1.10, 6.2
- Combustion Chamber ..... 3.39
- Connecting Rod Assembly ..... 3.63
- Connecting Rod Inspection ..... 3.58
- Console
  - Removal ..... 5.22–5.23
- Conversion Table..... 1.14
- Coolant
  - Drain / Fill ..... 2.26
  - Level Inspection ..... 2.24
- Coolant Flow Diagram..... 3.17
- Coolant Strength and Type ..... 2.23
- Cooling Fan
  - Circuit Breaker ..... 10.27
  - Cooling Fan Bypass Test..... 10.24
- Cooling System
  - Assembly View..... 3.17
  - Bleeding Procedure ..... 3.18
  - Hoses..... 2.25
  - Pressure Cap Test..... 3.13
  - Pressure Test..... 3.13
  - Specifications ..... 3.13
- CPS ..... 4.29

Crankcase	
Assembly.....	3.68
Disassembly / Inspection .....	3.46
Crankshaft	
Connecting Rod Bearing Selection .....	3.61
Connecting Rod Inspection .....	3.58
Installation .....	3.65
Main Bearing Selection .....	3.61
Removal / Inspection .....	3.50
Crankshaft Position Sensor (CPS) .....	4.29
Cylinder	
Inspection.....	3.53
Installation .....	3.64
Removal.....	3.54
Cylinder Head	
Assembly.....	3.74
Disassembly .....	3.37
Installation .....	3.75
Removal.....	3.36
Warp .....	3.37
Cylinder Leakdown Test.....	2.18

Needle Bearing .....	6.14
Operation .....	6.3
Roller and Pin Inspection .....	6.15
Shift Weights .....	6.14
Spider Removal .....	6.15
Spring .....	6.13
Drive Shaft	
Boot Inspection .....	2.28
CV Joint Handling.....	7.33
Installation (Front) .....	7.7
Installation (Rear).....	7.31
Removal (Front).....	7.6
Removal (Rear).....	7.30
Service (Rear).....	7.33
Driven Clutch	
Assembly.....	6.26
Assembly View.....	6.30
Bushing Service .....	6.24
Disassembly .....	6.22
Operation .....	6.3
Service.....	6.22

## D

Dash	
Removal.....	5.20
Dash Instruments / Controls .....	5.9
Decal Replacement .....	5.26
Decimal Equivalent Chart.....	1.17
Diagnostic Trouble Codes .....	4.35
Differential	
Assembly (INT'L).....	8.35
Bushing Replacement (INT'L) .....	8.32
Disassembly (INT'L).....	8.31
Operation (INT'L) .....	8.25
Differential Solenoid (INT'L).....	10.18
Digital Wrench	
Communication Errors.....	4.41
Diagnostic Connector .....	4.41
ECU Reprogramming .....	4.45
Guided Diagnostics .....	4.41
Overview .....	4.40
Serial Number.....	4.41
Updates.....	4.42
Version.....	4.42
Doors .....	5.7
Doors XP 4 .....	5.8
Drive Belt	
Inspection.....	6.11
Installation .....	6.11
Removal.....	6.10
Drive Clutch	
Assembly.....	6.19
Assembly View.....	6.12
Bushing Service .....	6.17
Button to Tower Clearance .....	6.15
Cover Bushing .....	6.17
Disassembly .....	6.13
Moveable Sheave Inspection .....	6.16

## E

ECU .....	4.17
Replacement .....	4.18, 4.45
EFI	
Diagnostic Trouble Codes .....	4.35
Operation Overview.....	4.16
Priming / Starting Procedure .....	4.17
Service Notes .....	4.5
Troubleshooting .....	4.39
EFI System	
Assembly View.....	4.6
Component Locations.....	4.7
Electrical	
AWD Breakout Diagram.....	10.44
Charging System Breakout Diagram .....	10.50
Chassis Power Breakout Diagram .....	10.47
Cooling System Breakout Diagram .....	10.46
Key-On Power Breakout Diagram.....	10.48
Lights Breakout Diagram.....	10.49
Speed Sensor Breakout Diagram .....	10.45
Torque Specifications .....	10.4
Electronic Control Unit (ECU) .....	4.17
Electronic Throttle Control (ETC) .....	4.32
Engine	
Assembly View.....	3.9–3.12
Balance Shaft Removal / Inspection.....	3.49
Bearing Selection Identification .....	3.60
Break-In Period .....	3.32
Breather Hose Inspection.....	2.18
Camshaft Installation / Timing .....	3.76
Camshaft Removal .....	3.33
Camshaft Sprocket Inspection.....	3.34
Connecting Rod Bearing Selection .....	3.61
Crankcase Assembly .....	3.68
Crankcase Disassembly / Inspection.....	3.46
Crankshaft Installation .....	3.65

## IX.2

Crankshaft Main Bearing Selection ..... 3.61  
 Crankshaft Removal / Inspection ..... 3.50  
 Cylinder / Piston Installation ..... 3.64  
 Cylinder / Piston Removal ..... 3.54  
 Cylinder Head Assembly ..... 3.74  
 Cylinder Head Disassembly ..... 3.37  
 Cylinder Head Installation ..... 3.75  
 Cylinder Head Removal ..... 3.36  
 Cylinder Head Warp ..... 3.37  
 Cylinder Inspection ..... 3.53  
 Exhaust Valve Lash - Tappet Selection Matrix ..... 3.84  
 Flywheel Installation ..... 3.73  
 Flywheel Removal ..... 3.44  
 Installation ..... 3.28  
 Intake Valve Lash - Tappet Selection Matrix ..... 3.83  
 Lower End Assembly ..... 3.60  
 Lower End Disassembly / Inspection ..... 3.43  
 Mounting ..... 3.31  
 Oil and Filter Change ..... 2.17  
 Oil Flow Chart ..... 3.5  
 Oil Level ..... 2.16  
 Piston / Connecting Rod Assembly ..... 3.63  
 Piston Disassembly / Inspection ..... 3.55  
 Piston Ring Installation ..... 3.62  
 Piston Ring Installed Gap ..... 3.57  
 Piston Ring Removal / Inspection ..... 3.56  
 Removal ..... 3.24  
 Service ..... 3.24  
 Special Tools ..... 3.3  
 Starter Drive Installation ..... 3.73  
 Stator Cover Installation ..... 3.73  
 Top End Assembly ..... 3.74  
 Top End Disassembly / Inspection ..... 3.33  
 Valve Cover Removal ..... 3.33  
 Valve Inspection ..... 3.38  
 Valve Sealing Test ..... 3.39  
 Valve Seat Reconditioning ..... 3.40  
 Engine Coolant Temp. Sensor (ECT) ..... 10.24  
 Engine Designation Number ..... 1.2  
 Engine Serial Number Location ..... 1.3  
 Engine Service Panel ..... 5.19  
 Engine, Camshaft Timing - Quick Reference ..... 3.80  
 Engine, Cooling System Troubleshooting ..... 3.87  
 Engine, Troubleshooting ..... 3.86  
 Engine, Valve Cover Installation ..... 3.85  
**EPS**  
     Breakout Diagram ..... 10.40  
     Operation ..... 10.39  
     Troubleshooting ..... 10.41  
 ETC ..... 4.32  
 Exhaust Valve Lash - Tappet Matrix ..... 3.84

**F**

Fan Control Circuit Bypass Test ..... 10.24  
 Fan Control Circuit Operation ..... 10.24  
 Final Drive  
     Torque Specifications ..... 7.2  
 Floor ..... 5.15  
     Removal ..... 5.22–5.23

Floor / Rocker Panels XP 4 ..... 5.16  
 Flywheel  
     Installation ..... 3.73  
     Removal ..... 3.44  
 Front A-arm  
     Replacement ..... 5.36  
 Front Body  
     Removal ..... 5.20  
 Front Bumper  
     Removal ..... 5.19  
 Front Caliper, Piston Bore I.D. .... 9.22  
 Front Gearcase  
     Assembly ..... 7.22  
     Disassembly / Inspection ..... 7.19  
     Installation ..... 7.25  
     Lubrication ..... 2.22  
     Removal ..... 7.18  
 Front Gearcase, Centralized Hilliard ..... 7.16  
 Front Propshaft  
     Installation ..... 7.9  
     Removal ..... 7.8  
 Fuel Filter ..... 2.11  
 Fuel Injector  
     Troubleshooting ..... 4.19  
 Fuel Injectors ..... 4.19  
 Fuel Line ..... 2.12  
 Fuel Lines  
     Removal / Installation ..... 4.10  
 Fuel Pump ..... 4.23  
     Replacement ..... 4.25  
 Fuel Sender  
     Test ..... 4.24  
 Fuel Sender Test ..... 10.26  
 Fuel System ..... 2.11  
 Fuel Tank  
     Assembly View ..... 4.9  
     Installation ..... 4.12, 4.15  
     Removal ..... 4.10, 4.14  
     Vent Line and Filter ..... 2.11  
 Fuse Box ..... 10.27  
 Fuse Box Detail ..... 10.28

**G**

Ground  
     Engine / Chassis ..... 2.31

**H**

Hazard Switch (INT'L) ..... 10.16  
 Head Lights ..... 10.21  
 Headlight Switch ..... 10.13  
 High Altitude Clutch Chart ..... 1.10, 6.2  
 Hood  
     Removal ..... 5.20  
 Hood / Front Body ..... 5.10

<b>I</b>	
Ignition Coil .....	10.20
Replacement .....	10.20
Test .....	10.21
Ignition Switch .....	10.14
Inner Plunging Joint / Boot	
Replacement .....	7.35
Instrument Cluster .....	10.6
Diagnostic Mode .....	10.11
Installation .....	10.12
Removal .....	10.12
Intake Valve Clearance - Tappet Selection Matrix .....	3.83

<b>K</b>	
Key-off Current Draw Test .....	10.30
Keys, Replacement .....	1.4

<b>L</b>	
Leakdown Test .....	2.18
Lights	
Front .....	10.21
Rear .....	10.23
Lower Steering Shaft	
Removal (EPS) .....	5.33
Lower Steering Shaft (EPS)	
Installation .....	5.33
Lubrication Grease Points .....	2.8
Lubrication Specifications .....	3.3
Lubrication Specifications (Engine) .....	3.32

<b>M</b>	
Main Frame .....	5.11–5.12
Maintenance	
Brake System .....	2.37
Cooling System .....	2.23
Electrical and Ignition .....	2.29
Engine .....	2.16
Fuel System .....	2.11
General Vehicle Inspection .....	2.10
Quick Reference Chart .....	2.6–2.7
Service Products and Lubricants .....	2.9
Steering .....	2.32
Transmission and Gearcases .....	2.21
Maintenance Chart .....	2.3
Master Cylinder	
Removal .....	9.8
Master Cylinder, Installation .....	9.8
Metric Bolt Torque Specification .....	1.15

<b>N</b>	
ne	
Valve Clearance Adjustment .....	3.81

<b>O</b>	
Oil Pressure Test .....	3.4
Open Circuit Voltage Test .....	10.35
Outer CV Joint / Boot	
Replacement .....	7.33

<b>P</b>	
Parking Brake	
Adjustment (INT'L) .....	9.12
Assembly View (INT'L) .....	9.11
Inspection (INT'L) .....	9.12
Parking Brake Caliper	
Assembly View (INT'L) .....	9.13
Disassembly (INT'L) .....	9.14
Installation (INT'L) .....	9.16
Pad Installation (INT'L) .....	9.15
Removal (INT'L) .....	9.14
Parking Brake Disc (INT'L) .....	9.16
Parking Brake Switch (INT'L) .....	10.17
Pedal Position Sensor (PPS) .....	4.33
Piston	
Disassembly / Inspection .....	3.55
Installation .....	3.64
Removal .....	3.54
Ring Groove Clearance .....	3.57
Ring Installation .....	3.62
Ring Installed Gap .....	3.57
Ring Removal / Inspection .....	3.56
Piston to Cylinder Clearance .....	3.57
Power Steering	
Assembly View .....	5.30
Power Steering Unit	
Installation .....	5.34
Removal .....	5.32
Pre-Ride / Daily Inspection .....	2.10
Propshaft	
Support Bearing Replacement .....	7.13
U-Joint Service .....	7.15
Publication Numbers .....	1.3
PVT	
Drying .....	2.27
Filter Service .....	2.27
PVT System	
Assembly .....	6.8
Belt Break-In .....	6.3
Disassembly .....	6.7
Maintenance .....	6.4
Overheating Diagnostics .....	6.5
Overview .....	6.3
Service .....	6.6
PVT Troubleshooting .....	6.31

<b>R</b>	
Radiator	
Removal / Installation .....	3.14
Radiator Inspection / Cleaning .....	2.26

## IX.4

Radius Rod	
Service	5.40
Rear Bumper	
Assembly View	5.18
Removal	5.19
Rear Cargo Box)	5.17
Rear Fender Flare Removal	5.21
Rear Fenders	5.17
Rear Propshaft	
Installation	7.10, 7.12
Removal	7.10, 7.12
Rear Stabilizer Bar	5.45
Rear Suspension	
Assembly View	5.44
Reflash Authorization	4.45
Regulator / Rectifier Location	10.32
Relays	10.29
Rocker Panel	
Removal	5.22–5.23
Rocker Panels	5.15
Rocker Panels XP 4	5.16

## S

Seat	
Removal	5.19
Seat Assembly Front	5.13
Seat Assembly Rear	5.14
Sensor, Pedal Position	4.33
Service Panel	5.19
Shift Cable	
Adjustment	8.4
Inspection	8.4
Inspection and Adjustment	2.10
Shift Lever	
Installation	8.4
Removal	8.3
Shock	
Disassembly	5.53
Replacement	5.47
Special Tools	5.52
Valve Shim Arrangement	5.52
Walker Evans 2.0 Assembly View	5.48
Walker Evans Rebuild Information	5.52
Walker Evans Service	5.50
Shock Piston Orientation, Walker Evans	5.52
Shock, Walker Evans 2.5, Assembly View	5.49
Shock, Walker Evans, Assembly	5.55
Shocks	5.46
Solenoid	
Rear Differential (INT'L)	10.18
Spark Plug Service	2.31
Special Tools	1.5
Body/Steering/Suspension	5.3
Brakes	9.3
Clutching	6.2
EFI	4.3
Electrical	10.4
Engine	3.3
Final Drive	7.2

Shock	5.52
Transmission	8.2
Specification	
Wheel Toe-Out	2.33
Specifications	
Brakes	9.3
Camshaft	3.34
Cooling System	3.13
Engine	3.6
Engine Lubrication	3.3, 3.32
Engine Oil Pressure	3.4
General	1.6
Transmission and Front Gearcase	2.21
Specifications, Walker Evans 2.0 Shocks	5.50
Speed Sensor	10.20
Speedometer	10.6
Spring	
Adjustment	2.35
Springs	5.46
Standard Bolt Torque Specification	1.15
Starter	
Drive Installation	3.73
One-Way Clutch Assembly	3.72
One-Way Clutch Disassembly	3.45
One-Way Clutch Inspection	3.44
Starter Motor	
Installation	10.37
Removal	10.37
Starter Solenoid	
Operation	10.37
Test	10.37
Starter System	
Troubleshooting	10.36
Stator	
Cover Installation	3.73
Stator Cover	3.43
Stator Tests	10.31
Steering	
Assembly View (Non-EPS)	5.27
Inspection	2.32
Steering Shaft	
Bearing Replacement	5.28
Removal (Non-EPS)	5.28
Steering Wheel	
Removal (Non-EPS)	5.28
Steering Wheel (EPS)	
Removal	5.31
Steering Wheel Freeplay	2.32
Suspension	
Compression Adjustment	2.36
Spring Adjustment	2.35
Walker Evans	2.35
Switch	
AWD/2WD	10.15
Brake Light	10.13
Gear Position	10.16
Hazard (INT'L)	10.16
Headlamp	10.13
Ignition	10.14
Parking Brake (INT'L)	10.17

---

Turn Signal (INT'L) ..... 10.16

Installation ..... 5.34  
Removal ..... 5.31

## T

Tail Lights.....	10.23
Tap/Drill Sizes .....	1.16
Temperature / Manifold Absolute Pressure Sensor (TMAP) .....	4.29
Thermostat Replacement .....	3.15
Throttle Body.....	4.31
Throttle Pedal	
Inspection.....	2.12
Tie Rod End Inspection .....	2.33
Tire	
Inspection.....	2.28
Pressure.....	2.29
TMAP .....	4.29
Toe Adjustment .....	2.34
Torque Specifications	
Body/Steering/Suspension.....	5.4
Brakes.....	9.3
Clutching .....	6.2
Electrical .....	10.4
Engine Components .....	3.8
Final Drive .....	7.2
Transmission .....	8.2
Wheel and Hub .....	2.28
Trailing Arm	
Service.....	5.41
Spherical Bearing Replacement .....	5.43
Transmission	
Assembly.....	8.18
Assembly (INT'L).....	8.37
Assembly View.....	8.46
Disassembly .....	8.12
Disassembly (INT'L) .....	8.26
Installation .....	8.8
Lubrication.....	2.21
Lubrication Specifications .....	8.2
Mounting and Torque Values .....	8.3
Output Shaft Backlash (INT'L).....	8.37
Output Shaft Backlash Procedure .....	8.18
Removal.....	8.5
Snorkel Shaft Removal .....	8.12
Troubleshooting .....	8.45
Transmission Lubrication .....	8.2
Transmission Switch.....	10.16
Trouble Codes.....	4.35
Troubleshooting	
Brake Noise.....	9.4
Brake System .....	9.35
Clutch.....	6.31
Fuel Injector.....	4.19
Transmission .....	8.45
Turn Signal Switch (INT'L).....	10.16

## U

Upper Steering Shaft (EPS)

## V

Valve	
Clearance Adjustment .....	3.81
Inspection.....	3.38
Sealing Test.....	3.39
Seat Reconditioning .....	3.40
Valve Clearance	
Exhaust Valve Lash - Tappet Selection Matrix.....	3.84
Intake Valve Lash - Tappet Selection Matrix.....	3.83
Valve Clearance Inspection .....	2.19
Valve Cover	
Removal.....	3.33
Valve Cover Installation.....	3.85
Valve Spring Removal.....	3.37
Vehicle Information, VIN Number .....	1.2
VIN.....	1.2
VIN Location .....	1.3
Voltage Drop Test .....	10.36

## W

Water Pump	
Housing Removal.....	3.44
Installation .....	3.19
Removal.....	3.19
Service.....	3.21
Wheel	
Installation .....	2.28
Removal.....	2.28
Wheel Alignment .....	2.33
Wheel Bearing	
Rear Service.....	7.27
Wheel Hub	
Assembly View.....	7.39

## IX.6

---

# HARNES - CHASSIS, RZR XP 1000

**WIRE COLOR LEGEND**

BG	BEIGE (TAN)
BK	BLACK
BU	LIGHT BLUE
DB	DARK BLUE
BN	BROWN
GN	GRAY
GN	LIGHT GREEN
DG	DARK GREEN
OG	ORANGE
PK	PINK
RD	RED
VT	VIOLET (PURPLE)
WH	WHITE
YE	YELLOW
CL	CLEAR

TWO WIRE COLORS ARE SHOWN WITH MAIN/TRACE COLORS. EXAMPLE: RD/YE = RED WITH YELLOW TRACE.

E = ENGINE GROUND  
C = CHASSIS GROUND  
NC = SWITCH NORMALLY CLOSED  
NO = SWITCH NORMALLY OPEN  
HARNES: 2412277-02  
SHEET NO. 1 OF 2

## TAIL LIGHT HARNESS



## ETC THROTTLE BODY

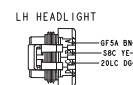
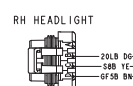

## FUSE/RELAY CENTER

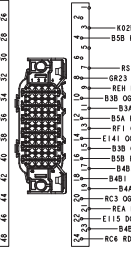
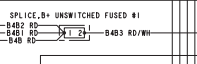
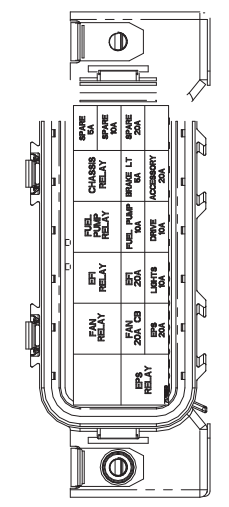

**INSTRUMENT CLUSTER**

PIN	FUNCTION	PIN	FUNCTION
1	CAN HIGH	9	
2	CAN LOW	10	
3	SWITCHED POWER (+)	11	FUEL LEVEL INPUT
4	CONSTANT POWER (+)	12	BLACKOUT MODE
5	POWER GROUND	13	
6	RIGHT TURN SIGNAL INPUT	14	
7		15	AMBIENT AIR TEMPERATURE
8	HIGH BEAM SWITCH INPUT	16	SPARE

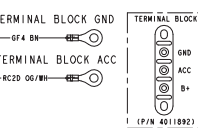
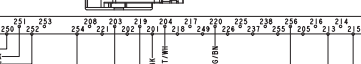
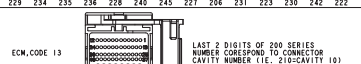
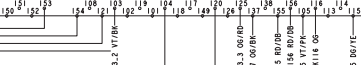
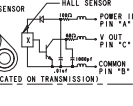
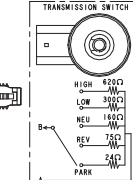
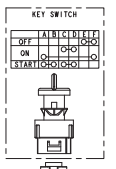



# HARNESS - CHASSIS, RZR XP 1000

WIRE COLOR LEGEND	
BG	BEIGE (TAN)
BL	BLACK
BU	LIGHT BLUE
DB	DARK BLUE
BR	BROWN
GY	GRAY
GN	LIGHT GREEN
DG	DARK GREEN
OG	ORANGE
PK	PINK
RE	RED
VT	VIOLET (PURPLE)
WH	WHITE
YE	YELLOW
CL	CLEAR
TWO WIRE COLORS ARE SHOWN WITH MAIN/TRACK COLORS. EXAMPLE: RD/YE = RED WITH YELLOW TRACE.	



E = ENGINE GROUND  
 C = CHASSIS GROUND  
 NC = SWITCH NORMALLY CLOSED  
 NO = SWITCH NORMALLY OPEN  
 HARNESS: 2412271-02  
 SHEET NO. 2 OF 2

INDEX	CCT #	TYPE	GAUGE	COLOR	SCHEMATIC CABLE/WIRE TERMINATION TABLE			FUNCTION	
					FROM COMPONENT	FROM PORT	TO COMPONENT		
1	20LA	TXL	0.8	DG	HEADLIGHT SWITCH	3	SPLICE, LOW BEAM	2	LOW BEAM, SWITCH OUT
2	20LB	TXL	0.8	DG	RH HEADLIGHT	B	SPLICE, LOW BEAM	1	LOW BEAM, RH
3	20LC	TXL	0.8	DG	LH HEADLIGHT	C	SPLICE, LOW BEAM	1	LOW BEAM, LH
4	30A	TXL	0.8	OG	SPLICE, BRAKE	1	BRAKE PRESSURE SWITCH	B	BRAKE SWITCH, OUT
5	30B	TXL	0.8	OG	SPLICE, BRAKE	1	KEY SWITCH, KEY START	1	BRAKE SWITCH, KEY START
6	30C	TXL	0.8	OG	SPLICE, BRAKE	2	RELAY/FUSE BLOCK	35	BRAKE SWITCH, LIGHT FUSE
7	40	TXL	0.8	DG/WH	KEY SWITCH	A	START SOLENOID	1	START SOLENOID CONTROL GROUND
8	50	TXL	0.8	WH	HEADLIGHT SWITCH	2	HEADLIGHT SWITCH	4	JUMPER, HEADLIGHT SWITCH
9	B2A	TXL	2.0	RD	START SOLENOID B+	1	RELAY/FUSE BLOCK	34	CHASSIS RELAY POWER IN
10	B3A	TXL	1.0	RD	RELAY/FUSE BLOCK	11	FAN B+, FUSE IN	1	FAN B+, FUSE IN
11	B3B	TXL	1.0	OG/BK	RELAY/FUSE BLOCK	15	RELAY/FUSE BLOCK	10	FAN B+, FUSED RELAY IN
12	B4A	TXL	2.0	RD	RELAY/FUSE BLOCK	19	START SOLENOID B+	1	EFI POWER UNFUSED
13	B4B	TXL	2.0	RD	RELAY/FUSE BLOCK	23	SPLICE, B+ UNSWITCHED FUSED #1	1	UNSWITCHED FUSED B+, EFI FUSE OUT
14	B4B1	TXL	1.0	RD	RELAY/FUSE BLOCK	18	SPLICE, B+ UNSWITCHED FUSED #1	1	UNSWITCHED FUSED B+, EFI RELAY IN
15	B4B2	TXL	0.5	RD	RELAY/FUSE BLOCK	17	SPLICE, B+ UNSWITCHED FUSED #1	1	UNSWITCHED FUSED B+, EFI RELAY COIL HI
16	B4B3	TXL	1.0	RD/WH	SPLICE, B+ UNSWITCHED FUSED #1	4	SPLICE, B+ UNSWITCHED FUSED #2	1	UNSWITCHED FUSED B+, SPLICE
17	B4B31	TXL	0.8	RD	SPEEDOMETER	4	SPLICE, B+ UNSWITCHED FUSED #2	2	UNSWITCHED FUSED B+, SPEEDOMETER
18	B4B32	TXL	1.0	RD/WH	KEY SWITCH	C	SPLICE, B+ UNSWITCHED FUSED #2	2	UNSWITCHED FUSED B+, KEY
19	B4B33	TXL	0.5	RD	DIAGNOSTIC	A	SPLICE, B+ UNSWITCHED FUSED #2	2	UNSWITCHED FUSED B+, DIAGNOSTIC
20	B5A	TXL	2.0	RD	RELAY/FUSE BLOCK	12	START SOLENOID B+	1	EPS B+, UNFUSED
21	B5B	TXL	2.0	RD	RELAY/FUSE BLOCK	18	RELAY/FUSE BLOCK	4	UNSWITCHED FUSED B+, EPS FUSE OUT
22	C01_1	TXL	0.5	BK	ECM, CODE 13	201	CRANK POSITION SENSOR	2	CRANKSHAFT SENSOR (-)
23	C01_2	TXL	0.5	WH	ECM, CODE 13	213	CRANK POSITION SENSOR	1	CRANKSHAFT SENSOR (+)
24	C01_3	SHLD	0.35	SHLD	SPLICE, CPS SHIELD	2	SPLICE, SHIELD	1	GROUND, CRANK POSITION SENSOR
25	C02_1	TXL	0.5	BK	ECM, CODE 13	254	IGNITION COIL	3	IGNITION DRIVER 2 (PTO)
26	C02_2	TXL	0.5	RD	IGNITION COIL	2	SPLICE, IGNITION POWER	1	EFI B+, COIL
27	C02_3	TXL	0.5	WH	ECM, CODE 13	256	IGNITION COIL	1	IGNITION DRIVER 1 (MAG)
28	C02_4	SHLD	0.35	SHLD	TRIM FLUSH Ø IGNITION COIL	-	SPLICE, SHIELD	2	GROUND, IGNITION COIL
29	C03_1	TXL	0.5	DB/BK	ECM, CODE 4	111	PEDAL POSITION SENSOR	F	PEDAL POSITION 2
30	C03_2	TXL	0.5	VT/BK	ECM, CODE 4	103	PEDAL POSITION SENSOR	E	PPS2 SENSOR RETURN 3
31	C03_3	TXL	0.5	OG/RD	ECM, CODE 4	125	PEDAL POSITION SENSOR	D	SV PEDAL SUPPLY 2
32	C04_1	TXL	0.5	DB/WH	ECM, CODE 4	121	PEDAL POSITION SENSOR	A	PEDAL POSITION 1
33	C04_2	TXL	0.5	VT	ECM, CODE 4	106	PEDAL POSITION SENSOR	B	PPS1 SENSOR RETURN 2
34	C04_3	TXL	0.5	OG/BN	ECM, CODE 13	210	PEDAL POSITION SENSOR	C	SV PEDAL SUPPLY 1
35	C1H	TXL	0.5TP	YE	ECM, CODE 4	132	SPLICE, CAN HIGH	1	CAN HIGH, ECM
36	C1L	TXL	0.5TP	DG	ECM, CODE 4	144	SPLICE, CAN LOW	1	CAN LOW, ECM
37	C2H	TXL	0.5TP	YE	DIAGNOSTIC	H	SPLICE, CAN HIGH	2	CAN HIGH, DIAGNOSTIC
38	C2L	TXL	0.5TP	DG	DIAGNOSTIC	G	SPLICE, CAN LOW	2	CAN LOW, DIAGNOSTIC
39	C3H	TXL	0.5TP	YE	SPEEDOMETER	1	SPLICE, CAN HIGH	2	CAN HIGH, SPEEDOMETER
40	C3L	TXL	0.5TP	DG	SPEEDOMETER	2	SPLICE, CAN LOW	2	CAN LOW, SPEEDOMETER
41	C4H	TXL	0.5TP	YE	SPLICE, CAN HIGH	1	EPS SIGNAL	8	CAN HI, EPS
42	C4L	TXL	0.5TP	DG	SPLICE, CAN LOW	1	EPS SIGNAL	4	CAN LO, EPS
43	E104	TXL	0.5	VT	ECM, CODE 4	104	T-MAP	1	MAP SENSOR RETURN 4
44	E105	TXL	0.5	VT/PK	ECM, CODE 4	105	ETC THROTTLE BODY	4	TPS SENSOR RETURN 1
45	E112	TXL	0.5	VT/WH	ECM, CODE 4	112	FUEL PUMP & SENDER	1	FUEL SENSOR
46	E115	TXL	0.5	DG/YE	ECM, CODE 4	115	RELAY/FUSE BLOCK	22	EFI RELAY COIL LO
47	E120	TXL	0.5	GY	ECM, CODE 4	120	AWD SWITCH	3	AWD REQUEST INPUT
48	E123	TXL	0.5	WH	ECM, CODE 4	123	TRANSMISSION SWITCH	B	TRANSMISSION GEAR
49	E135	TXL	0.5	OG	SPLICE, BRAKE	2	ECM, CODE 4	135	BRAKE SWITCH, ECM IN
50	E137	TXL	0.5	OG/BK	ECM, CODE 4	137	ETC THROTTLE BODY	2	3.3V SUPPLY, TPS
51	E140	TXL	0.5	GY	ECM, CODE 4	140	RELAY/FUSE BLOCK	38	CHASSIS RELAY COIL LO
52	E141	TXL	0.5	OG/BK	ECM, CODE 4	141	RELAY/FUSE BLOCK	14	COOLING FAN RELAY
53	E142	TXL	0.5	DG/YE	ECM, CODE 4	142	RELAY/FUSE BLOCK	30	FUEL PUMP COIL LO
54	E203	TXL	0.5	DG	ECM, CODE 13	203	ETC THROTTLE BODY	3	THROTTLE POSITION SENSOR 1
55	E204	TXL	0.5	VT/WH	ECM, CODE 13	204	SPLICE, SENSOR GROUND	2	SENSOR GROUND, ECM
56	E204A	TXL	0.5	VT/WH	COOLANT TEMP SENSOR	A	SPLICE, SENSOR GROUND	1	SENSOR GROUND, TEMP SENSOR
57	E204B	TXL	0.5	VT/WH	TRANSMISSION SWITCH	A	SPLICE, SENSOR GROUND	2	SENSOR GROUND, TRANS
58	E215	TXL	0.5	YE	ECM, CODE 13	215	COOLANT TEMP SENSOR	B	COOLANT TEMPERATURE SENSOR
59	E219	TXL	0.5	YE	ECM, CODE 13	219	T-MAP	4	MANIFOLD PRESSURE SENSOR SIGNAL
60	E220	TXL	0.5	DG/BN	ECM, CODE 13	220	ETC THROTTLE BODY	1	THROTTLE POSITION SENSOR 2
61	E223	TXL	0.5	OG	ECM, CODE 13	223	T-MAP	3	SV SENSOR SUPPLY 2, MAP
62	E227	TXL	0.5	DB	ECM, CODE 13	227	T-MAP	1	MANIFOLD AIR TEMPERATURE SENSOR
63	E232	TXL	0.5	GN/RD	ECM, CODE 13	232	VEHICLE SPEED SENSOR	C	VEHICLE SPEED SENSOR
64	E243	TXL	0.5	WH	ECM, CODE 13	243	PTO FUEL INJECTOR	1	INJECTOR DRIVER 2 (PTO)
65	E244	TXL	0.5	BK	ECM, CODE 13	244	MAG FUEL INJECTOR	1	INJECTOR DRIVER 1 (MAG)
66	E246	TXL	0.5	BN/WH	ECM, CODE 13	246	AWD COIL	B	AWD CONTROL
67	GCPS	TXL	0.5	BN	CRANK POSITION SENSOR	3	SPLICE, CPS SHIELD	1	GROUND, CRANK POSITION SENSOR
68	GF1	TXL	0.8	BN	SPLICE, FRONT GND	1	SPLICE, GROUND DASH	2	GROUND, DASH SPLICE
69	GF1A	TXL	0.5	BN	AWD SWITCH	2	SPLICE, GROUND DASH	1	GROUND, AWD SWITCH
70	GF1B	TXL	0.5	BN	HEADLIGHT SWITCH	7	SPLICE, GROUND DASH	1	GROUND, HEADLIGHT SWITCH
71	GF1C	TXL	0.5	BN	SPLICE, LED, CATHODE BLACK	2	SPLICE, GROUND DASH	1	GROUND, INTERIOR LED
72	GF1D	TXL	0.5	BN	DIAGNOSTIC	D	SPLICE, GROUND DASH	1	GROUND, DIAGNOSTIC
73	GF2	TXL	0.8	BN	SPLICE, FRONT GND	1	SPLICE, LIGHT GROUND	2	GROUND, FRONT LIGHT SPLICE
74	GF3	TXL	1.0	BN	12V RECEPTACLE LO	1	SPLICE, ACCESSORY GROUND	1	GROUND, FRONT 12V RECEPTACLE
75	GF4	TXL	1.0	BN	TERMINAL, ACCESSORY GROUND	1	TERMINAL, BLOCK GND	1	GROUND, TERMINAL BLOCK
76	GF5A	TXL	0.8	BN	LH HEADLIGHT	A	SPLICE, LIGHT GROUND	1	GROUND, LH HDLT
77	GF5B	TXL	0.8	BN	RH HEADLIGHT	D	SPLICE, LIGHT GROUND	1	GROUND, RH HDLT
78	GR10	TXL	0.8	BN	FUEL PUMP & SENDER	4	GROUND, CHASSIS REAR1	1	GROUND, FUEL PUMP
79	GR11	TXL	0.5	BN	FUEL PUMP & SENDER	2	GROUND, CHASSIS REAR1	1	GROUND, FUEL LEVEL
80	GR20	TXL	0.8	BN	START SOLENOID	2	GROUND, CHASSIS REAR2	1	GROUND, START SOLENOID
81	GR21	TXL	0.5	BN	GROUND, CHASSIS REAR2	1	SPLICE, SHIELD SPLICE	2	GROUND, SHIELD SPLICE
82	GR22	TXL	0.8	BN	TAIL LIGHT HARNESS	1	GROUND, CHASSIS REAR2	1	GROUND, TAIL LIGHT
83	GR23	TXL	0.5	BN	GROUND, CHASSIS REAR2	1	RELAY/FUSE BLOCK	8	GROUND, EPS RELAY COIL
84	GR24	TXL	0.5	BN	VEHICLE SPEED SENSOR	B	GROUND, CHASSIS REAR2	1	GROUND, SPEED SENSOR
85	GR25	TXL	0.8	BN	SPEEDOMETER	5	GROUND, CHASSIS REAR2	1	GROUND, SPEEDOMETER
86	GR26	TXL	0.5	BN	GROUND, IGNITION COIL	P1	GROUND, CHASSIS REAR2	1	GROUND, IGNITION COIL BODY
87	GR31	TXL	0.8	BN	SPLICE, FRONT GND	2	GROUND, CHASSIS REAR3	1	GROUND, FRONT
88	GR32	TXL	1.0	BN	FAN	A	GROUND, CHASSIS REAR3	1	GROUND, FRONT FAN
89	GR33	TXL	1.0	BN	SPLICE, ACCESSORY GROUND	2	GROUND, CHASSIS REAR3	1	GROUND, ACCESSORY
90	GR34	TXL	2.0	BN	EPS POWER	B	GROUND, CHASSIS REAR3	1	GROUND, EPS POWER
91	GRE153	TXL	0.8	BN	ECM, CODE 4	153	GROUND, CHASSIS REAR1	1	GROUND, ECM
92	GRE154	TXL	0.8	BN	ECM, CODE 4	154	GROUND, CHASSIS REAR1	1	GROUND, ECM
93	GRE247	TXL	0.5	BN	ECM, CODE 13	247	GROUND, CHASSIS REAR1	1	GROUND, ECM
94	GRE250	TXL	0.8	BN	ECM, CODE 13	250	GROUND, CHASSIS REAR1	1	GROUND, ECM
95	K01	TXL	1.0	OG	KEY SWITCH	D	SPLICE, R/S B+1	2	KEY SWITCH B+, KEY OUT
96	K02	TXL	0.5	OG	SPLICE, R/S B+1	1	SPLICE, R/S B+2	1	KEY SWITCH B+, SPLICE
97	K02A	TXL	0.5	OG	VEHICLE SPEED SENSOR	A	SPLICE, R/S B+2	2	KEY SWITCH B+, VSS
98	K02B	TXL	0.5	OG	RELAY/FUSE BLOCK	3	SPLICE, R/S B+2	2	KEY SWITCH B+, EPS REL COIL POWER
99	K02C	TXL	0.8	OG	RELAY/FUSE BLOCK	27	SPLICE, R/S B+2	1	FUEL PUMP UNFUSED
100	K02C1	TXL	0.8	OG	RELAY/FUSE BLOCK	31	RELAY/FUSE BLOCK	26	FUEL PUMP POWER FUSED
101	K02C2	TXL	0.8	RD/BU	RELAY/FUSE BLOCK	29	FUEL PUMP & SENDER	3	FUEL PUMP RELAY OUT
102	K03	TXL	0.5	OG	SPEEDOMETER	3	SPLICE, R/S B+1	2	KEY SWITCH B+, SPEEDOMETER
103	K04	TXL	0.5	OG	DIAGNOSTIC	B	SPLICE, R/S B+1	2	KEY SWITCH B+, DIAGNOSTIC
104	K05	TXL	0.5	OG	EPS SIGNAL	3	SPLICE, R/S B+1	2	KEY SWITCH B+, EPS
105	K06	TXL	0.5	OG	AWD SWITCH	7	SPLICE, R/S B+1	1	AWD SWITCH LIGHT
106	K116	TXL	0.5	OG	SPLICE, R/S B+2	2	ECM, CODE 4	116	KEY SWITCH B+, ECM
107	M1_251	TXL	0.8	GN/BK	ECM, CODE 13	251	ETC THROTTLE BODY	6	ETC MOTOR (+)
108	M2_252	TXL	0.8	BN/BN	ECM, CODE 13	252	ETC THROTTLE BODY	5	ETC MOTOR (-)
109	RC1	TXL	2.0	RD	RELAY/FUSE BLOCK	37	SPLICE, CHASSIS	1	CHASSIS RELAY OUT
110	RC2	TXL	1.0	OG/WH	RELAY/FUSE BLOCK	36	SPLICE, CHASSIS	1	CHASSIS RELAY, ACC INPUT
111	RC2A	TXL	1.0	OG/WH	RELAY/FUSE BLOCK	40	SPLICE, B+ ACC FUSE OUT	1	B+ ACCESSORY FUSE OUT
112	RC2B	TXL	1.0	OG/WH	12V RECEPTACLE HI	1	SPLICE, B+ ACC FUSE OUT	2	B+ ACCESSORY FUSE OUT
113	RC2D	TXL	1.0	OG/WH	TERMINAL, BLOCK ACC	1	SPLICE, B+ ACC FUSE OUT	2	B+ ACCESSORY FUSE OUT
114	RC3	TXL	0.8	OG/WH	SPLICE, CHASSIS	2	RELAY/FUSE BLOCK	20	CHASSIS RELAY OUT, LIGHTS INPUT
115	RC4	TXL	0.8	RD/DG	RELAY/FUSE BLOCK	28	SPLICE, CHASSIS	2	CHASSIS RELAY, DRIVE INPUT
116	RC4F	TXL	0.8	RD/DG	RELAY/FUSE BLOCK	32	SPLICE, DRIVE	2	SWITCHED B+ DRIVE FUSE OUT
117	RC4F1	TXL	0.5	RD/DG	AWD COIL	C	SPLICE, DRIVE	1	SWITCHED B+, AWD COIL
118	RC4F2	TXL	0.5	RD/DG	SPLICE, LED, ANODE GREY	2	SPLICE, DRIVE	1	SWITCHED B+, INTERIOR LED
119	RC6	TXL	1.0	RD/YE	RELAY/FUSE BLOCK	24	SPLICE, LIGHTS B+	1	SPLICE, LIGHTS B+, LIGHTS FUSE OUT
120	RC6A	TXL	0.8	RD/YE	SPLICE, LIGHTS B+	1	TAIL LIGHT HARNESS	A	LIGHTS, TAILLIGHTS
121	RC6B	TXL	0.8	RD/YE	HEADLIGHT SWITCH	5	SPLICE, LIGHTS B+	2	LIGHTS, HDLT SWITCH IN
122	RC6B1	TXL	0.5	RD/YE	HEADLIGHT SWITCH	5	HEADLIGHT SWITCH	8	JUMPER
123	RD4	TXL	0.8	OG	RELAY/FUSE BLOCK	39	TAIL LIGHT HARNESS	B	BRAKE B+ FUSED
124	RE140	TXL	0.5	RD/DB	RELAY/FUSE BLOCK	33	SPLICE, EFI B+	1	SPLICE, EFI B+, CHASSIS RELAY COIL
125	RE155	TXL	0.8	RD/DB	SPLICE, EFI B+	2	ECM, CODE 4	155	EFI B+, ECM1
126	RE156	TXL	0.8	RD/DB	ECM, CODE 4	156	SPLICE, EFI B+	2	EFI B+, ECM2
127	REA	TXL	1.0	RD/DB	RELAY/FUSE BLOCK	21	SPLICE, EFI B+	1	EFI B+, EFI RELAY OUT
128	REB	TXL	0.5	RD/DB	PTO FUEL INJECTOR	2	SPLICE, EFI B+	2	EFI B+, PTO INJECTOR
129	REC	TXL	0.5	RD/DB	MAG FUEL INJECTOR	2	SPLICE, EFI B+	2	EFI B+, MAG INJECTOR
130	RED	TXL	0.8	RD/DB	BRAKE PRESSURE SWITCH	A	SPLICE, EFI B+	1	EFI B+, BRAKE SWITCH
131	REF	TXL	0.8	RD/DB	SPLICE, IGNITION POWER	2	SPLICE, EFI B+	2	EFI B+, IGNITION COIL
132	REH	TXL	0.5	RD/DB	SPLICE, EFI B+	1	RELAY/FUSE BLOCK	9	EFI B+, FAN COIL HI
133	REI	TXL	0.5	RD/DB	RELAY/FUSE BLOCK	25	SPLICE, EFI B+	1	EFI B+, FUEL PUMP COIL HI
134	RF1								

# HARNESS - BOX, RZR XP 1000

WIRE COLOR LEGEND	
BG	BEIGE (TAN)
BK	BLACK
BU	LIGHT BLUE
DB	DARK BLUE
BN	BROWN
GY	GRAY
GN	LIGHT GREEN
DG	DARK GREEN
OG	ORANGE
PK	PINK
RD	RED
VT	VIOLET (PURPLE)
WH	WHITE
YE	YELLOW
CL	CLEAR

TWO WIRE COLORS ARE SHOWN WITH MAIN/TRACE COLORS.  
EXAMPLE: RD/YE = RED WITH YELLOW TRACE.

 = ENGINE GROUND  
 = CHASSIS GROUND  
 NC = SWITCH NORMALLY CLOSED  
 NO = SWITCH NORMALLY OPEN  
 HARNESS: 2412623-01  
 SHEET NO. 3 OF 3

SCHEMATIC CABLE/WIRE TERMINATION TABLE									
INDEX	CCT #	TYPE	GAUGE	COLOR	FROM COMPONENT	FROM PORT	TO COMPONENT	TO PORT	FUNCTION
1	001	TXL	0.5	BN	RH TAILLIGHT	C	SPLICE, GROUND	I	GROUND, RH
2	002	TXL	0.5	BN	LH TAILLIGHT	C	SPLICE, GROUND	I	GROUND, LH
3	003	TXL	0.5	BN	SPLICE, GROUND	2	CHASSIS HARNESS	C	GROUND, CHASSIS
4	004	TXL	0.5	OG	RH TAILLIGHT	B	SPLICE, BRAKE LIGHT	I	BRAKE LIGHT, RH
5	005	TXL	0.5	OG	LH TAILLIGHT	B	SPLICE, BRAKE LIGHT	I	BRAKE LIGHT, LH
6	006	TXL	0.5	OG	SPLICE, BRAKE LIGHT	2	CHASSIS HARNESS	B	BRAKE LIGHT
7	007	TXL	0.5	RD/YE	RH TAILLIGHT	A	SPLICE, TAILLIGHT	I	TAILLIGHT B+, RH
8	008	TXL	0.5	RD/YE	LH TAILLIGHT	A	SPLICE, TAILLIGHT	I	TAILLIGHT B+, LH
9	009	TXL	0.5	RD/YE	SPLICE, TAILLIGHT	2	CHASSIS HARNESS	A	TAILLIGHT B+

03/13/13

